

(12) STANDARD PATENT
(19) AUSTRALIAN PATENT OFFICE

(11) Application No. **AU 2005299916 B2**

(54) Title
Catheter with a pre-shaped distal tip

(51) International Patent Classification(s)
A61M 25/00 (2006.01)

(21) Application No: **2005299916** (22) Date of Filing: **2005.10.19**

(87) WIPO No: **WO06/047169**

(30) Priority Data

(31) Number (32) Date (33) Country
10/970,204 **2004.10.21** **US**

(43) Publication Date: **2006.05.04**

(44) Accepted Journal Date: **2011.02.10**

(71) Applicant(s)
Boston Scientific Limited

(72) Inventor(s)
Farnholtz, Roger;Armstrong, Kirsten C.;Barry, Gitanjali V.;McFerran, Sean

(74) Agent / Attorney
Watermark Patent and Trade Marks Attorneys, Level 2 302 Burwood Road, Hawthorn, VIC, 3122

(56) Related Art
US 4898591
US 5358493

(19) World Intellectual Property Organization
International Bureau



(43) International Publication Date
4 May 2006 (04.05.2006)

PCT

(10) International Publication Number
WO 2006/047169 A1

- (51) International Patent Classification:
A61M 25/00 (2006.01)
- (21) International Application Number:
PCT/US2005/037575
- (22) International Filing Date: 19 October 2005 (19.10.2005)
- (25) Filing Language: English
- (26) Publication Language: English
- (30) Priority Data:
10/970,204 21 October 2004 (21.10.2004) US
- (71) Applicant (for all designated States except US): **BOSTON SCIENTIFIC SCIMED, INC.** [US/US]; One Scimed Place, Maple Grove, Minnesota 55311 (US).
- (72) Inventors; and
- (75) Inventors/Applicants (for US only): **MCFERRAN, Sean** [US/US]; 5791 Dichondra Place, Newark, CA 94560 (US). **FARNHOLTZ, Roger** [US/US]; 495 Kansas Way, Fremont, CA 94538 (US). **BARRY, Gitanjali V.** [US/US]; 37628 Canterbury Street, Fremont, CA 94536 (US). **ARM-STRONG, Kirsten C.** [US/US]; 1038 Clayton Street, San Francisco, CA 94117 (US).
- (74) Agent: **SEAGER, Glenn M., Agent;** CROMPTON SEAGER & TUFTE LLC, 1221 Nicollet Avenue, Suite 800, Minneapolis, Minnesota 55403 (US).

- (81) Designated States (unless otherwise indicated, for every kind of national protection available): AE, AG, AL, AM, AT, AU, AZ, BA, BB, BG, BR, BW, BY, BZ, CA, CH, CN, CO, CR, CU, CZ, DE, DK, DM, DZ, EC, EE, EG, ES, FI, GB, GD, GE, GH, GM, HR, HU, ID, IL, IN, IS, JP, KE, KG, KM, KP, KR, KZ, LC, LK, LR, LS, LT, LU, LV, LY, MA, MD, MG, MK, MN, MW, MX, MZ, NA, NG, NI, NO, NZ, OM, PG, PH, PL, PT, RO, RU, SC, SD, SE, SG, SK, SL, SM, SY, TJ, TM, TN, TR, TT, TZ, UA, UG, US, UZ, VC, VN, YU, ZA, ZM, ZW.
- (84) Designated States (unless otherwise indicated, for every kind of regional protection available): ARIPO (BW, GH, GM, KE, LS, MW, MZ, NA, SD, SL, SZ, TZ, UG, ZM, ZW), Eurasian (AM, AZ, BY, KG, KZ, MD, RU, TJ, TM), European (AT, BE, BG, CH, CY, CZ, DE, DK, EE, ES, FI, FR, GB, GR, HU, IE, IS, IT, LT, LU, LV, MC, NL, PL, PT, RO, SE, SI, SK, TR), OAPI (BF, BJ, CF, CG, CI, CM, GA, GN, GQ, GW, ML, MR, NE, SN, TD, TG).

Published:

- with international search report
- before the expiration of the time limit for amending the claims and to be republished in the event of receipt of amendments

[Continued on next page]

(54) Title: CATHETER WITH A PRE-SHAPED DISTAL TIP

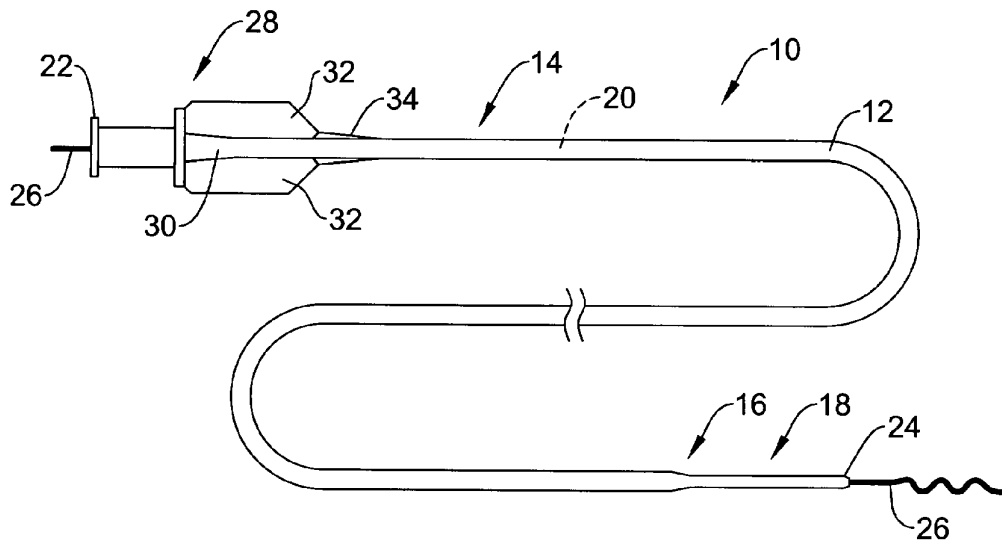

(57) Abstract: Catheters having a pre-shaped tip configuration are disclosed. A catheter in accordance with an illustrative embodiment of the present invention can include an elongated tubular shaft equipped with a distal tip section having a pre-shaped tip configuration that can be used to facilitate tracking of the device through particular locations of the vasculature. The catheter may include a number of features that transition the stiffness and flexibility characteristics of the device and provide a means to radio-graphically visualize the catheter within the body.



WO 2006/047169 A1



For two-letter codes and other abbreviations, refer to the "Guidance Notes on Codes and Abbreviations" appearing at the beginning of each regular issue of the PCT Gazette.

CATHETER WITH A PRE-SHAPED DISTAL TIP

Field

The present invention relates generally to the field of medical devices. More
5 specifically, the present invention pertains to catheters having a pre-shaped distal tip.

Background

Medical catheters such as guide catheters are utilized in a wide variety of
interventional procedures to facilitate advancement of therapeutic devices to target
10 locations within the body. In applications involving the neurovasculature, for example,
such devices can be used in conjunction with a guidewire to advance an endovascular coil,
atherectomy catheter, drug delivery catheter, or other such therapeutic device to select
vascular regions within the body to treat vascular disease.

In certain applications, it may be desirable to impart a particular shape to the
15 catheter tip to facilitate tracking of the catheter through tortuous anatomy, or to advance
the catheter beyond a lesion or other obstruction within the body. In the treatment of
aneurysms, for example, such shaped catheter tips can be used to reach select vascular
regions within the body such as the anterior communicating artery or the posterior
communicating artery. Once positioned, such tip shapes can also be used to maintain the
20 stability of the catheter at the site of the aneurysm by using the tip shape to stabilize a
portion of the catheter body against the vessel wall while maintaining the tip at the site of
the aneurysm.

Shaping of catheter tips is typically accomplished in a clinical or surgical setting
by bending the tip manually to a desired shape, and then setting the shape within the aid
25 of shaping equipment. In a steam-shaping process, for example, the shape of the catheter
tip is typically formed by the physician bending the tip to a particular shape and then
steaming the tip to impart the desired shape. While a number of different shapes can be
formed in this manner, such techniques often require the physician to perform additional
steps in preparation for the procedure, thus increasing the time required to perform the
30 interventional procedure. Moreover, the efficacy of such techniques is often dependent on
the skill of the physician and the precision of the equipment employed.

Summary

The present invention pertains to catheters having a pre-shaped distal tip.

According to an aspect of the present invention there is provided a catheter, including:

5 an elongated tubular shaft including an outer layer formed of a polymer, the outer layer having an inner diameter and an outer diameter, the outer layer including a proximal shaft section formed of a first polymer, an intermediate shaft section formed of a second polymer, a distal shaft section formed of a third polymer, and an interior lumen adapted to slidably receive a guidewire;

10 a reinforcement extending substantially from the inner diameter of the outer layer to the outer diameter of the outer layer, the reinforcement including a first coil segment having a plurality of wire coil layers that are completely encased within the polymer forming the outer layer and a second coil segment extending distally from the first coil segment into the distal shaft section and including a single wire coil layer that is
15 completely encased within the polymer forming the outer layer, wherein the first coil segment extends from the intermediate shaft section, through the proximal shaft section, to a position substantially adjacent a proximal end of the elongated tubular shaft;

a distal tip section having a pre-shaped curved tip configuration;

20 wherein the elongated tubular shaft includes an inner layer or coating of lubricious material disposed adjacent the interior lumen; and

an intermediate layer disposed between the outer layer and the inner layer or coating.

In certain embodiments, for example, each of the shaft sections may comprise a material having a different durometer that transitions the stiffness of the shaft from a
25 relatively stiff configuration along the proximal shaft section to a relatively flexible configuration along the distal shaft section. In some embodiments, the shaft may include an inner layer or coating of lubricious material adapted to reduce friction within the interior lumen. Other features relating to the performance and radiopacity characteristics of the catheter are also described herein.

30 The catheter can include a distal tip section having a pre-shaped tip configuration that can be used to facilitate tracking of the device through particular locations of the vasculature. In certain embodiments, for example, such pre-shaped tip configuration can be employed to facilitate insertion of the catheter at locations within the body such as the

anterior communicating artery, the posterior communicating artery, the ophthalmic artery, the middle cerebral artery, and/or the superior cerebellar artery. The distal tip section can be pre-shaped into any number of desired tip configurations, including, for example, an angled tip configuration, a curved tip configuration, a J-shaped tip configuration, a C-shaped tip configuration, and an S-shaped tip configuration. In use, such pre-shaped tip configurations may reduce the shape variability that can result from shaping the catheter tip manually in a clinical or surgical setting, and may reduce the overall time required to perform the interventional procedure.

Brief Description of the Drawings

Figure 1 is a plan view showing a catheter in accordance with an exemplary embodiment of the present invention;

Figure 2 is a longitudinal cross-sectional view showing a distal portion of the catheter of Figure 1 in greater detail;

Figure 3 is a side plan view showing the catheter of Figure 1 equipped with a distal tip section in accordance with an illustrative embodiment having an angled tip configuration;

Figure 4 is a side plan view showing the catheter of Figure 1 equipped with a distal tip section in accordance with an illustrative embodiment having a curved tip configuration;

Figure 5 is a side plan view showing the catheter of Figure 1 equipped with a distal tip section in accordance with an illustrative embodiment having a J-shaped tip configuration;

Figure 6 is a side plan view showing the catheter of Figure 1 equipped with a distal tip section in accordance with an illustrative embodiment having a C-shaped tip configuration;

Figure 7 is a side plan view showing the catheter of Figure 1 equipped with a distal tip section in accordance with an illustrative embodiment having an S-shaped tip configuration; and

Figure 8 is a side plan view of an illustrative shape retention mandrel for use with a catheter of the present invention.

Detailed Description

The following description should be read with reference to the drawings, in which like elements in different drawings are numbered in like fashion. The drawings, which are not necessarily to scale, depict selected embodiments and are not intended to limit the scope of the invention. Although examples of construction, dimensions, and materials are illustrated for the various elements, those skilled in the art will recognize that many of the examples provided have suitable alternatives that may be utilized.

Figure 1 is a plan view of a catheter 10 in accordance with an exemplary embodiment of the present invention. Catheter 10, illustratively a guide catheter for use in neurovascular and peripheral interventions, includes an elongated tubular shaft 12 having a proximal shaft section 14, an intermediate shaft section 16, and a distal shaft section 18. The shaft 12 may define an interior lumen 20, which in the illustrative embodiment of Figure 1 extends from a proximal end 22 of the catheter 10 to a distal end 24 thereof. In certain embodiments, the interior lumen 20 of the shaft 12 can be configured to slidably receive a guidewire 26 that can be used to track other therapeutic devices to target locations within the body. In certain applications, for example, catheter 10 can be used to facilitate advancement of the guidewire 26 to select vascular regions within the body such as the anterior communicating artery or posterior communicating artery for the treatment of aneurysms.

The proximal shaft section 14 can include a hub and strain relief assembly 28 that can be used as an aid to manipulate the catheter 10 from a location outside of the body. The hub and strain relief assembly 28 may include a main body 30 having a number of fins 32 that can be used to improve gripping and to facilitate labeling for product identification, and a strain relief member 34 adapted to provide additional column strength and rigidity to the proximal shaft section 14. A second strain relief member (not shown) may be disposed on the shaft 12 distally of strain relief member 34 to provide additional strain relief to the proximal shaft section 14 of the catheter 10, if desired.

The length of the various shaft sections 14,16,18 may vary depending on the particular location within the body to be traversed, and the performance characteristics (e.g. flexibility, column strength, etc.) desired in the catheter 10. In certain embodiments, for example, the proximal shaft section 14 may be made available in 80 cm, 105 cm, and 125 cm embodiments, although other lengths are possible. In such embodiments, the overall length of the catheter 10 may be 105 cm, 130 cm, and 150 cm, respectively, which

is typical for catheters employed in neurovascular and/or peripheral interventions. It should be understood, however, that the length of the catheter 10 may vary to permit the catheter 10 to be used at other locations within the body and/or to perform other types of interventional procedures.

5 Figure 2 is a longitudinal cross-sectional view showing a distal portion of the catheter 10 of Figure 1 in greater detail. As can be seen in Figure 2, the shaft 12 can include an inner layer or coating 36 of lubricious material that extends along all or a portion of the catheter 10. In certain embodiments, for example, the inner layer or coating 36 may comprise a hydrophilic polymer material that reduces friction within the interior
10 lumen 20. An example of such lubricious material is polytetrafluoroethylene (PTFE), which is commercially available from Dupont under the trademark TEFLON®. Other materials such as polyethylene (PE), polypropylene (PP), polyvinylchloride (PVC), ethylvinylacetate (EVA), polyurethanes, polyamides, polyethyleneteraphthalate (PET), ethylene-chlorofluoroethylene (ECTFE), fluorinated ethylenepropylene (FEP),
15 polychlorotrifluoroethylene (PCTFE), polyvinylfluoride (PVF), polyvinylidene fluoride (PVDF), and their mixtures and/or copolymers thereof may also be employed, if desired.

The interior lumen 20 may be uniform along the proximal, intermediate, and distal shaft sections 14,16,18 of the catheter 10, or may vary in dimension at one or more locations along the length of the shaft 12, if desired. In the illustrative embodiment
20 depicted in Figure 2, for example, the interior lumen 20 is substantially uniform along the entire length of the shaft 12, having an inner diameter D_1 in the range of about 0.012 to 0.021 inches, and more specifically 0.014 to 0.019 inches, which is sufficiently large to permit many conventional guidewires to be inserted and advanced through the interior lumen 20. The inner diameter D_1 may be made larger or smaller, however, to permit other
25 sized guidewires and/or other intravascular devices to be advanced through the interior lumen 20, if desired.

The shaft 12 may further a number of outer layers that can be used to transition the stiffness of the shaft 12 from a relatively stiff configuration along the proximal shaft section 14 to a relatively flexible configuration along the distal shaft section 18. In certain
30 embodiments, for example, each of the proximal, intermediate, and distal shaft sections 14,16,18 may comprise a different polymeric material adapted to impart a desired strength, flexibility, hardness, and/or other desired characteristic to the catheter 10. In the illustrative embodiment of Figure 2, for example, proximal shaft section 14 may include

an outer layer segment 38 of material having a relatively high durometer whereas the distal shaft section 18 may include an outer layer segment 40 of material having a relatively low durometer. In one such embodiment, the outer layer segment 38 of the proximal shaft section 14 may comprise a relatively stiff polymeric material such as
5 PEBAX® 7233 whereas the outer layer segment 40 of the distal shaft section 18 may comprise relatively flexible polymeric material such as PEBAX® 2533. The outer layer segments 38,40 may each comprise a single polymer, multiple polymers, or a blend of polymers, as desired.

To further transition the stiffness along the length of the shaft 12, the intermediate shaft section 16 can include one or more outer layer segments comprising a material having a durometer that is intermediate to that of the proximal and distal shaft sections 14,18. In one illustrative embodiment, for example, the intermediate shaft section 16 may include a first outer layer segment 42 of PEBAX® 5533 that spans the length of the shaft 12 from a first location 44 to a second location 46 thereof. A second outer layer segment
15 48 of PEBAX® 4033 can be provided along the portion of the intermediate shaft section 16 extending from the second location 46 to a third location 50 thereof. While the illustrative embodiment of Figure 2 shows the use of two outer layer segments 42,48 along the length of the intermediate shaft section 16, it should be understood that a greater or lesser number of segments can be provided, if desired. Moreover, as with the outer layer
20 segments 38,40 of the proximal and distal shaft sections 14,18, the outer layer segments 42,48 of the intermediate shaft section 16 can include a single polymer, multiple polymers, or a blend of polymers, as desired.

In certain embodiments, an intermediate layer of material can be provided between the inner layer 36 and the various outer layers segments 38,40,42,48 of the shaft 12 to
25 further transition the stiffness of the catheter 10. As shown in Figure 2, for example, a first intermediate layer segment 52 can be provided about the inner layer 36 along a portion of the proximal, intermediate, and distal shaft sections 14,16,18, terminating distally at a location 54 proximal to the distal end 24 of the shaft 12. The first intermediate layer segment 52 may comprise a polymeric material such as PEBAX® 5533 having an
30 elasticity sufficient to permit the distal portion of the catheter 10 to radially flex or bend while providing additional column strength to withstand buckling or kinking as the catheter 10 is tracked through the body. The first intermediate layer segment 52 may

further act as a tie layer in certain embodiments to facilitate bonding of the inner layer 36 with the various outer layer segments 38,40,42,48 of the shaft 12.

In some embodiments, a second intermediate layer segment 56 may be provided about the inner layer 36 along a portion of the distal shaft section 18, extending from location 54 to a second location 58 proximal to the distal end 24 of the catheter 10. In contrast to intermediate layer segment 52 described above, the second intermediate layer segment 56 may comprise a relatively flexible material such as PEBAX® 2533, which further aids in transitioning the stiffness along the length of the distal shaft section 18.

The wall thickness of the various shaft sections 14,16,18 may be reduced along one or more sections of the shaft 12 to transition the flexibility, torqueability, and other desired characteristics of the catheter 10. In certain embodiments, for example, the proximal shaft section 14 may have a wall thickness in the range of about 0.01 to 0.02 inches, and more specifically 0.015 inches, whereas the distal shaft section 18 may have a smaller wall thickness in the range of about 0.004 to 0.006 inches, and more specifically 0.0055 inches. To further transition the stiffness, the intermediate shaft section 16 may include a tapered section 60 wherein the profile of the catheter 10 transitions from about 2.4 Fr. to about 1.7 Fr. If desired, a second tapered section 62 can be provided along the distal shaft section 18 to further reduce the profile at the distal end 24 of the catheter 10.

A reinforcement member (e.g. a braid, weave, etc.) can be provided along all or a portion of the shaft length, providing additional stiffness and torsional rigidity to the catheter 10, if desired. The reinforcement member may include a first coil segment comprising three wire coil layers 64 disposed along the length of the shaft 12 from a location at or near the strain relief member 34 to a location 66 along the intermediate shaft section 16. As shown in Figure 2, the coil layers 64 forming the first coil segment can be encased entirely within the outer layers 38,42,48 of the proximal and intermediate shaft section 14,16.

A second coil segment comprising a single wire coil layer 68 may extend distally from location 66 along the intermediate shaft section 16 to a point at or near location 58 along the distal shaft section 18. In contrast to the first coil segment, the second coil segment may have a greater amount of flexibility to facilitate bending or flexion of the distal portion of the catheter 10 as it is advanced through tortuous anatomy. As with the wire coil layers 64 forming the first coil segment, the single wire coil layer 68 can be

encased entirely within the outer layers 40,48 of the intermediate and distal shaft sections 16,18.

While two coil segments are specifically depicted in the embodiment of Figure 2, it should be understood that a greater or lesser number of coil segments can be provided, either continuously or at discrete intervals along the length of the shaft 12. Moreover, while the transition in stiffness along the length of the shaft 12 can be accomplished by varying the number of coil layers encased within the shaft 12, other factors such as the size of the coils employed, the material selection, and/or the pitch of the coils can also be varied to alter the performance characteristics of the catheter 10. In the latter case, for example, the coil pitch of the coils 68 forming the second coil segment can be made greater than the coil pitch of the coils 64 forming the first coil segment, thus imparting a greater amount of flexibility to the distal portion of the catheter 10. The types of wire or wires (e.g. round, flat, etc.) used in forming the various coil segments may also be altered to change the performance characteristics of the catheter 10, if desired. In certain embodiments, the selection of materials used to form each of the coil segments can also be varied to impart a desired flexibility to the catheter 10.

The catheter 10 may include one or more radiopaque features that permit the device to be visualized within the body using a fluoroscope or other such device. In certain embodiments, for example, a distal radiopaque marker 70 encased within the distal shaft section 18 can be provided to permit the physician to radiographically visualize the distal end 24 of the catheter 10 as it is advanced through the body. The distal radiopaque marker 70 may include a suitable material such as platinum, gold, or tantalum, or a combination of materials such as platinum/iridium that can be used to radiographically determine the location of the catheter 10 within the vasculature. The distal radiopaque marker 70 should typically be placed at or near the distal end 24 of the shaft 12 to permit the physician to accurately determine the location of the catheter tip. In some embodiments, for example, the radiopaque marker can be positioned at a location about 0.75 cm away from the distal end 24 of the catheter 10. It should be understood, however, that other placement positions are possible.

In certain embodiments, the catheter 10 may further include a proximal radiopaque marker 72 encased with the distal shaft section 18 at a location proximal to the distal radiopaque marker 70. In the treatment of brain aneurysms, for example, such proximal radiopaque marker 72 can be used to align the coil delivery wire used in many

endovascular coiling procedures. As with the distal radiopaque marker 70, the proximal radiopaque marker 72 can include a radiopaque material or combination of radiopaque materials that provide sufficient contrast to permit fluoroscopic visualization. The placement location of the proximal radiopaque marker 72 will typically vary based on the particular anatomy to be traversed, and the type of intravascular device to be inserted through the interior lumen 20. In endovascular coiling techniques involving the neurovasculature, for example, the proximal radiopaque marker band 72 can be placed at a location of about 30 cm from the distal end 24 of the shaft 12, although other placement positions are possible.

To further aid in visualization of the catheter 10 within the body, one or more of the shaft sections 14,16,18 can be loaded or otherwise include a radiopaque material. In certain embodiments, for example, the proximal, intermediate, and distal shaft sections 14,16,18 may be loaded with tungsten (W), bismuth subcarbonate ((BiO₂)CO₃), barium sulfate (BaSO₄) or other suitable radiopaque agent. The amount of loading may vary depending on the amount of radiopacity necessary to provide sufficient visibility of the catheter 10 on a fluoroscopic monitor. In embodiments employing a radiopaque filler of BaSO₄, for example, a 20% by weight concentration will typically provide sufficient visibility of the catheter 10 within the body. It should be understood, however, that other factors such as the wall thickness and material composition of the shaft 12 can also affect the amount of loading necessary to provide sufficient visibility.

In some embodiments, all or a portion of the outer surface of the catheter 10 may include a lubricious coating that can be used to facilitate tracking of the catheter 10 through the tortuous anatomy and/or beyond lesions or other obstructions within the body. Examples of suitable lubricious materials may include hydrophilic polymers such as polyarylene oxides, polyvinylpyrrolidones, polyvinylalcohols, hydroxy alkyl celluloses, aligins, saccharides, caprolactones, and the like, or mixtures and combinations thereof. Lubricious materials such as that described above with respect to the inner layer or coating 36 can also be utilized, if desired.

The coated length along which the lubricious coating is applied to the catheter 10 may vary depending on the overall length of the shaft 12. In those embodiments where the overall length of the catheter 10 is approximately 150 cm, for example, the length of the lubricious coating may be provided on the distal-most 100 cm length of the shaft 12, providing additional lubricity to the leading portion of the catheter 10. Conversely, in

those embodiments where the overall length of the catheter is approximately 130 cm and 105 cm, the length of the lubricious coating may be provided on a 97 cm and 72 cm length of the shaft 12, respectively, providing additional lubricity in those embodiments. The length and/or placement location of the lubricious coating may vary, however, depending on the performance characteristics desired in the catheter 10 as well as other factors.

The catheter 10 can include a number of pre-shaped tip configurations that can be used to facilitate tracking of the device through select locations within the vasculature. In some cases, such pre-shaped tip configurations may reduce the shape variability that often results from shaping the tip manually in a clinical or surgical setting. Moreover, such pre-formed tip shapes may reduce the overall time required to perform the interventional procedure by obviating the need to shape the tip just prior to insertion within the patient's body.

Figure 3 is a side plan view showing the catheter 10 of Figure 1 equipped with a distal tip section 74 in accordance with an illustrative embodiment of the present invention having an angled tip configuration. As can be seen in Figure 3, the distal tip section 74 of catheter 10 may include a first straight section A of the shaft 12, a curved section B of the shaft 12 extending distally of the first straight section A, and a second straight section C of the shaft 12 extending distally from the curved section B.

The curved section B of the shaft 12 can be configured to orient the distal end 24 at an angle θ_1 relative to a general longitudinal axis L of the shaft 12. In certain embodiments, for example, the curved section B can be configured to orient the second straight section C at an angle θ_1 of about 25° to 65° , and more specifically 35° to 55° relative to the longitudinal axis L. Angles θ_1 greater or lesser than these ranges can be employed, however.

The distal end 24 of the catheter 10 can be located a distance D_1 away from the outer periphery of the first straight section A, which, in certain embodiments, may represent the maximum profile of the distal tip section 74. The angle θ_1 at which the second straight section C is oriented relative to the longitudinal axis L as well as the length of the second straight section C can be varied to permit the catheter 10 to be used in particular locations of the patient's anatomy. In neurological and peripheral interventions, for example, such dimensions can be selected to form a distal tip section 74 having a profile (i.e. D_1 dimension) of approximately 0.22 inches, allowing the catheter

10 to be easily inserted into difficult anatomy such as the anterior or posterior communicating artery.

Figure 4 is a side plan view showing the catheter 10 of Figure 1 equipped with a distal tip section 76 in accordance with an illustrative embodiment of the present invention having a curved tip configuration. As can be seen in Figure 4, the distal tip section 76 of catheter 10 may include a straight section D of the shaft 12, and a curved section E of the shaft 12 extending distally from the straight section D.

The curved section E of the shaft 12 can be configured to orient the distal end 24 at an angle θ_2 relative to the general longitudinal axis L of the catheter 10. In the illustrative embodiment depicted in Figure 4, for example, the distal end 24 of the catheter 10 is shown oriented at angle θ_2 of approximately 90° . It should be understood, however, that the curved section E of the shaft 12 can be configured to orient the distal end 24 at an angle θ_2 greater or lesser than 90° , if desired.

As with the embodiment of Figure 3, the distal end 24 of the catheter 10 can be located a distance D_2 away from the outer periphery of the straight section D, which, in certain embodiments, may represent the maximum profile of the distal tip section 76. In one illustrative embodiment, for example, the curved section E of the shaft 12 can be configured such that the distal end 24 is located a distance D_2 of approximately 0.22 inches away from the outer periphery of the straight section D. Other configurations are, of course, possible.

Figure 5 is a side plan view showing the catheter 10 of Figure 1 equipped with a distal tip section 78 in accordance with an illustrative embodiment of the present invention having a J-shaped tip configuration. As can be seen in Figure 5, the distal tip section 78 of catheter 10 may include a first straight section F of the shaft 12, a curved section G of the shaft 12 extending distally from the first straight section F, and a second straight section H of the shaft 12 extending distally from the curved section G.

In the illustrative embodiment of Figure 5, the curved section G of the shaft 12 can be configured to orient the distal end 24 in a proximal direction, forming a J-shaped portion of the catheter 10. The rise and run of the curved section G may be defined generally by reference to angle θ_3 , which defines the angle at which a tangent line intersects the curved section G from a known point 80 along the longitudinal axis L. In certain embodiments, for example, the curved section G may define an angle θ_3 of

approximately 170° , orienting the distal end 24 of the shaft 12 proximally a distance D_3 (e.g. 0.2 inches) away from the distal-most portion of the curved section G.

Figure 6 is a side plan view showing the catheter 10 of Figure 1 equipped with a distal tip section 82 in accordance with an illustrative embodiment of the present invention having a C-shaped tip configuration. As can be seen in Figure 6, the distal tip section 82 of catheter 10 may include a first straight section I of the shaft 12, a first curved section J of the shaft 12 extending distally from the first straight section I, a second straight section K of the shaft 12 extending distally from the first curved section J, and a second curved section L of the shaft 12 extending distally from the second straight section K.

The first curved section J of the shaft 12 can be configured to orient the second straight section K at an angle θ_4 relative to the general longitudinal axis L of the catheter 10. The second curved section L of the shaft 12, in turn, can be configured to orient the distal end 24 at an angle θ_5 relative to the general longitudinal axis L. The various angles θ_4 , θ_5 and section lengths can be selected to form a C-shaped section 84 having an overall length defined by dimension D_4 , which in the illustrative embodiment of Figure 6 extends from the distal end of the first straight section I to the distal-most portion of the second curved section L. The particular length D_4 imparted to the distal tip section 82 may vary depending on the intended use of the catheter 10. In neurological and peripheral interventions, for example, the C-shaped section 84 can be configured to have a length D_4 of about 0.5 inches, although other lengths are possible.

Figure 7 is a side plan view showing the catheter 10 of Figure 1 equipped with a distal tip section 86 in accordance with an illustrative embodiment of the present invention having an S-shaped tip configuration. As can be seen in Figure 7, the distal tip section 86 of catheter 10 may include a first straight section M of the shaft 12, a first curved section N of the shaft 12 extending distally from the first straight section M, a second straight section O of the shaft 12 extending distally from the first curved section N, a second curved section P of the shaft 12 extending distally from the second straight section O, a third straight section Q of the shaft 12 extending distally from the second curved section P, a third curved section R of the shaft 12 extending distally from the third straight section Q, and a fourth straight section S of the shaft 12 extending distally from the third curved section R.

The first curved section N of the shaft 12 can be configured to orient the second straight section O at an angle θ_6 away from the general longitudinal axis L of the shaft 12. The second curved section P of the shaft 12, in turn, can be configured to orient the third straight section Q at an angle θ_7 relative to the longitudinal axis L. The distance D_5 between the distal end of the first straight section M and the portion of the third straight section Q crossing the longitudinal axis L may define the first leg of an S-shaped portion 88 of the distal tip section 86.

As can be further seen in Figure 7, the third curved section R may bend and orient the fourth straight section S of the shaft 12 at an angle θ_8 relative to the third straight section Q, forming a second leg of the S-shaped section 88 having a length defined by distance D_6 . The various section lengths and angles can also be selected such that length D_6 of the second leg is smaller than the length D_5 of the first leg. In one illustrative embodiment, for example, the length D_6 of the second leg can be approximately 0.08 inches whereas the length D_5 of the first leg can be approximately 0.36 inches. Other configurations wherein the length D_6 of the second leg is greater than or substantially equal to the length D_5 of the first leg can also be employed, if desired. In some embodiments, the overall length (i.e. $D_5 + D_6$) of the S-shaped section 88 can be approximately 0.44 inches.

To retain the shape of any of the above distal tip sections 74,76,78,84,86 prior to use and/or during sterilization, a shape retention mandrel can be inserted into the interior lumen 20 of the catheter 10. As shown in Figure 8, for example, a shape retention mandrel 90 comprising a wire member 92 having a proximal end 94 and a distal end 96 can be sized to fit within the interior lumen 20 of the catheter 10 prior to shaping. In some embodiments, a handle grip 98 coupled to the proximal end 94 of the wire mandrel 90 can be provided to facilitate insertion of the wire mandrel 90 into the catheter 10, if desired. The shape retention mandrel 90 can be provided as part of a kit or packaging containing the sterilized catheter 10, or as a separate member that is later inserted into the catheter 10 by the physician.

Having thus described the several embodiments of the present invention, those of skill in the art will readily appreciate that other embodiments may be made and used which fall within the scope of the claims attached hereto. Numerous advantages of the invention covered by this document have been set forth in the foregoing description. It will be understood that this disclosure is, in many respects, only illustrative. Changes may

be made in details, particularly in matters of shape, size and arrangement of parts without exceeding the scope of the invention.

THE CLAIMS DEFINING THE INVENTION ARE AS FOLLOWS:

1. A catheter, including:

an elongated tubular shaft including an outer layer formed of a polymer, the outer layer having an inner diameter and an outer diameter, the outer layer including a proximal shaft section formed of a first polymer, an intermediate shaft section formed of a second polymer, a distal shaft section formed of a third polymer, and an interior lumen adapted to slidably receive a guidewire;

a reinforcement extending substantially from the inner diameter of the outer layer to the outer diameter of the outer layer, the reinforcement including a first coil segment having a plurality of wire coil layers that are completely encased within the polymer forming the outer layer and a second coil segment extending distally from the first coil segment into the distal shaft section and including a single wire coil layer that is completely encased within the polymer forming the outer layer, wherein the first coil segment extends from the intermediate shaft section, through the proximal shaft section, to a position substantially adjacent a proximal end of the elongated tubular shaft;

a distal tip section having a pre-shaped curved tip configuration;

wherein the elongated tubular shaft includes an inner layer or coating of lubricious material disposed adjacent the interior lumen; and

an intermediate layer disposed between the outer layer and the inner layer or coating.

2. The catheter of claim 1, wherein the inner layer or coating of lubricious material includes a hydrophilic polymer.

3. The catheter of claim 1 or 2, wherein the intermediate layer terminates distally at a location proximal to the distal end of the elongated tubular shaft.

4. The catheter of any one of the preceding claims, wherein the first polymer of the proximal shaft section has a durometer greater than the third polymer of the distal shaft section.

5. The catheter of claim 4, wherein the second polymer of the intermediate shaft section has a durometer greater than the third polymer of the distal shaft section and a durometer less than the first polymer of the proximal shaft section.
6. The catheter of any one of the preceding claims, wherein the intermediate shaft section includes a first intermediate layer segment formed of a first material, and a second intermediate layer segment formed of a second material different than the first material.
7. The catheter of claim 6, wherein the first material of said first intermediate layer segment has a durometer greater than the second material of said second intermediate layer segment.
8. The catheter of any one of the preceding claims, further including an outer coating of lubricious material disposed along all or a portion of the elongated tubular shaft.
9. The catheter of any one of the preceding claims, further including a first radiopaque marker encased within the distal shaft section of the outer layer.
10. The catheter of claim 9, further including a second radiopaque marker encased within the distal shaft section of the outer layer proximal to the first radiopaque marker.
11. The catheter of any one of the preceding claims, wherein the elongated tubular shaft includes radiopaque filler.
12. The catheter of any one of claims 1-11, wherein said pre-shaped tip configuration includes an angled tip configuration.
13. The catheter of any one of claims 1-11, wherein said pre-shaped tip configuration includes a multi-curved tip configuration.
14. The catheter of any one of claims 1-11, wherein said pre-shaped tip configuration includes a J-shaped tip configuration.

15. The catheter of any one of claims 1-11, wherein said pre-shaped tip configuration includes a C-shaped tip configuration.

16. The catheter of any one of claims 1-11, wherein said pre-shaped tip configuration includes an S-shaped tip configuration.

5 17. The catheter of any one of the preceding claims, further including a mandrel disposed within the interior lumen of the elongated tubular shaft.

18. A catheter substantially as herein described with reference to the accompanying drawing.

10

BOSTON SCIENTIFIC LIMITED

WATERMARK PATENT & TRADE MARK ATTORNEYS

P28560AU00

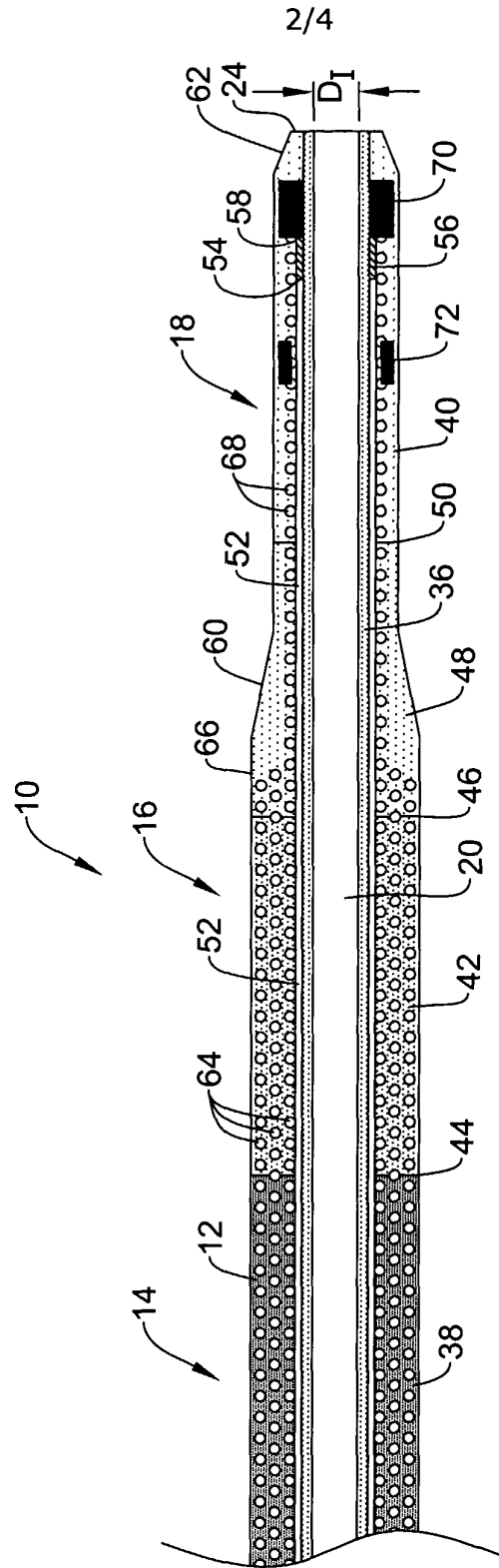

Figure 2

