

April 2, 1935.

D. KARRON

1,996,337

HAND BAG

Filed Dec. 20, 1933

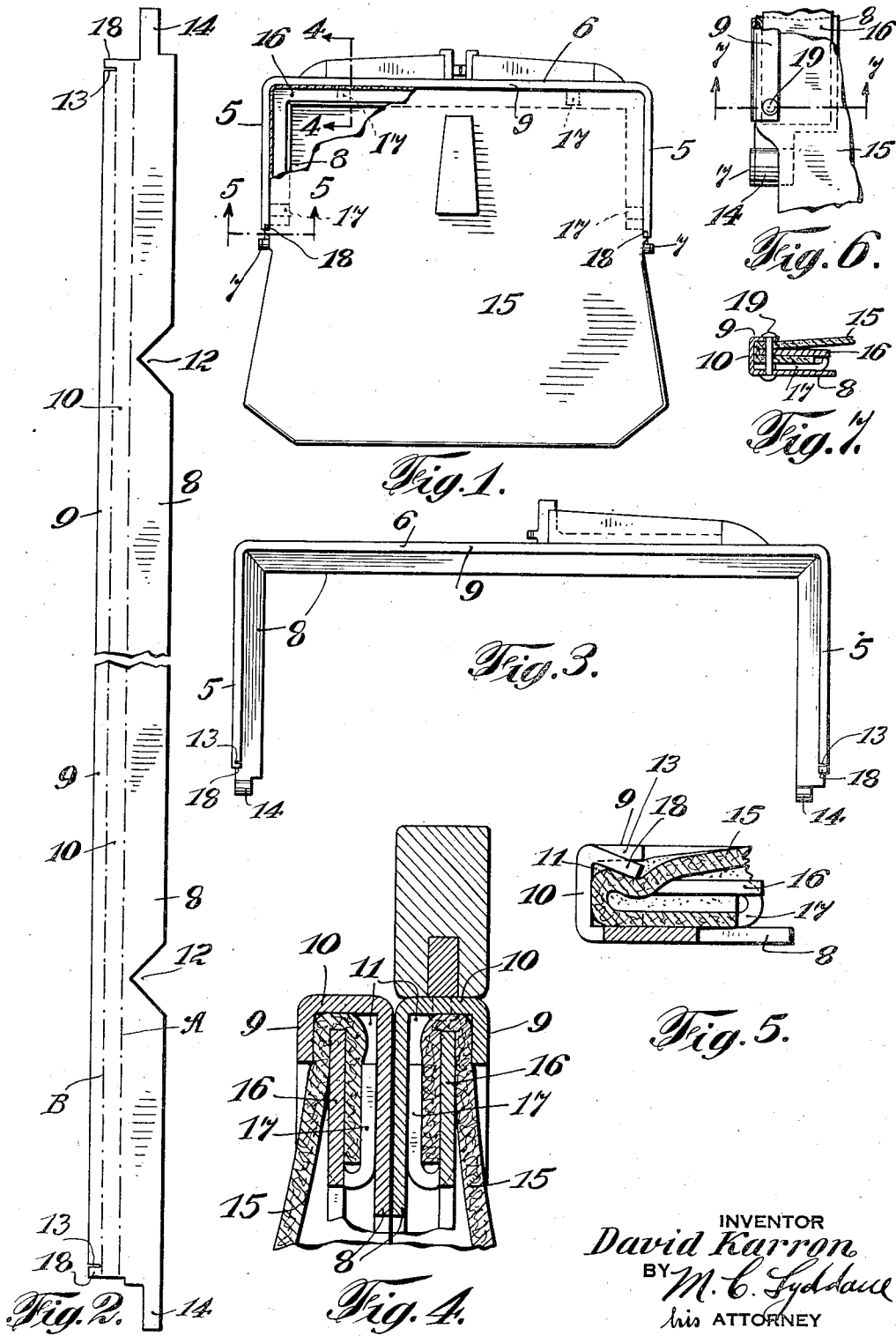

INVENTOR
David Karron
BY *M. C. Lydhaue*
his ATTORNEY

UNITED STATES PATENT OFFICE

1,996,337

HAND BAG

David Karron, Brooklyn, N. Y.

Application December 20, 1933, Serial No. 703,196

3 Claims. (Cl. 150—29)

This invention relates to hand bags and has for its general object and purpose to provide an improved frame structure for the bag pouch or body, of novel form and great durability, and which imparts to the completed article a neat and attractive appearance.

It is a more particular object of my invention to provide a hand bag frame comprising the usual hingedly connected members, each of said frame members having a shallow continuous channel, to receive the edge of the pouch material, with a wide flange at the inner side thereof and a relatively narrow flange at the outer side of said channel. This outer side flange may be of less width than the transverse thickness of the frame member and is structurally continuous from end to end thereof, without the usual miter joints at the corners of the frame. Thus, fabrication of the frame members is simplified and the labor costs reduced.

The edge of the pouch material is preferably attached to a metal inlay strip, one edge of which is covered by said material for insertion into the frame channel, and it is a further object of the invention in one embodiment thereof to provide simple and effective means for preventing relative displacement of the frame member and inlay from their assembled positions.

With the above and other objects in view, the invention consists in the improved hand bag and in the form, construction and relative arrangement of its several parts, as will hereafter be more fully described, illustrated in the accompanying drawing and subsequently incorporated in the subjoined claims.

In the drawing, wherein I have disclosed one simple and practical embodiment of my present improvements, and in which similar reference characters designate corresponding parts throughout the several views,

Figure 1 is a side elevation, partly broken away, illustrating a hand bag provided with my new frame.

Fig. 2 is a plan view of the die-stamped metal blank from which a frame member is formed.

Fig. 3 is an outer side elevation of a completely formed frame member.

Fig. 4 is a transverse sectional view, on an enlarged scale, taken on the line 4—4 of Fig. 1.

Fig. 5 is a horizontal sectional view, taken on the line 5—5 of Fig. 1.

Fig. 6 is a fragmentary elevation showing a modification of one feature of the invention, and

Fig. 7 is a horizontal sectional view taken on the line 7—7 of Fig. 6.

In the drawing, for convenient illustration, I have shown a hand bag having a three-sided frame, each frame member including parallel vertical end sections or legs 5, connected by the horizontal intermediate section 6. The corresponding sections 5 of the two frame members, at their extremities, are connected by the usual hinge 7.

Referring now to Figures 2 and 4 of the drawing, it will be seen that each frame member is formed from a sheet metal strip, and comprises spaced inner and outer flanges 8 and 9 respectively, extending inwardly in substantially parallel relation from the transverse connecting wall 10 of the frame member. The inner flanges 8 of the two frame members are relatively wide and have face to face contact with each other when the bag is closed, while the outer flanges 9 are comparatively narrow. These latter flanges are of a width not exceeding, and preferably less than the transverse thickness of the frame member, so that in conjunction with the flanges 8 and the wall 10, they form the comparatively shallow, continuous inwardly opening channels 11, in which the edges of the pouch material are adapted to be secured, as will be presently explained.

The frame blank, as seen in Figure 2, is provided at properly spaced points with the V-shaped recesses 12, the edges of which are disposed substantially in right angular relation to each other. These recesses extend substantially across the width of the flange 8. At a point suitably spaced from each end of the blank, the part forming the flange 9 is transversely cut or slit, as at 13, and each end of the blank is provided with a narrow extension 14 from which a hinge sleeve is formed. The blank is first bent along the longitudinal lines indicated at A and B and then bent transversely at each of the recesses 12. The edges of said recesses are thus brought into abutting contact and are permanently connected in a miter joint by welding or solder. The flange 9, being very narrow, will easily bend at the frame corners without recessing or wrinkling of the metal. Therefore, production will be increased and labor costs reduced.

While the edges of the pouch 15 may be secured in the channels 11 in various ways, I preferably employ for this purpose a metal inlay 16 in the form of a continuous metal strip, corresponding in contour to the frame member. On the inner edge of this strip, at suitably spaced points, the bendable lugs 17 are formed. The edge of the pouch material is placed upon one side of said inlay strip and the lugs 17 are then

bent and tightly clinched upon said material. The material is then folded over the opposite edge of said strip, and together with said edge of the strip, is inserted into the frame channel 5 11, the lugs 17 bearing against the flange 8. The pouch material is thus tightly confined between the outer edge of the inlay strip and the inner edge of the flange 9, said edges securely gripping the material and preventing its disconnection 10 from the inlay without bending or distortion of the flanges 8 and 9 from their normal positions.

The end portions 18 of the flange 9, produced by the slits 13, are now bent inwardly, as shown in Fig. 5, to depress or indent the pouch material 15 beyond the ends of the inlay 16 and into the plane thereof. Thus the inlay and attached edge of the pouch are positively locked within the channel of the frame member and the bag material is tightly compressed by the inlay against 20 the flange 9 and top wall 10 of the frame member. This indentation or depression, being quite small and located adjacent to the hinge 7, will be inconspicuous. However, if desired, instead of thus bending or distorting the ends of the 25 flanges 9, the inlay 16 and the flanges 8 and 9 may be provided with apertures to receive a suitable fastening rivet, as indicated at 19, in Figs. 6 and 7 of the drawing.

From the above description, considered in connection with the accompanying drawing, the construction and several advantages of my present invention will be readily understood. By means 30 thereof the required number of mechanical operations in the production of such bag frames is reduced to a minimum, while the narrow outer side flanges 9 framing the bag pouch, in contrast to the transverse dimension of the frame when 35 closed, materially enhances the attractive appearance of the hand bag. The inner flanges 8, having a width at least twice as great as the outer flanges 9, afford an extensive area of contact between the frame members when the bag is closed and tend to strongly resist bending or 40 distorting strains.

Any desired type of latch means may be provided for the purpose of releasably holding the 45 frame members in closed position.

The particular construction of the metal inlay 16 above described is merely suggestive, as various other structural forms thereof, subserving substantially the same purpose, might be employed. Likewise, the several other detail features of the present disclosure may be incorporated in alternative embodiments thereof, which are comprehended as fairly within the spirit and scope of the invention as claimed.

What I claim is:

1. In a hand bag, a pair of frame members, each having a continuous inwardly opening channel and an outer side flange structurally continuous from one end to the other of the frame member, and having a uniform width not 15 exceeding the transverse dimension of the frame member, a pouch, an inlay member attached to a marginal edge of the pouch material and inserted therewith into the channel of the frame member said inlay being of less length than the channel, and opposite end portions of said outer side flange being inwardly bent to indent the pouch material beneath the ends of said inlay member. 20

2. In a hand bag, a frame member having a 25 continuous inwardly opening channel, a pouch, an inlay member attached to a marginal edge of the pouch material and inserted therewith into the channel of the frame member, said inlay being of less length than the channel, and one side wall of the frame member, at its opposite ends and beyond the ends of the inlay, having 30 portions thereof inwardly bent to partially close the channel and retain the inlay member therein.

3. In a hand bag, a frame member having a 35 continuous inwardly opening channel, a pouch, an inlay member attached to a marginal edge of the pouch material and inserted therewith into the channel of the frame member, said inlay being of less length than the channel, and one side wall 40 of the frame member, at its opposite ends, having portions thereof inwardly bent to indent the pouch material beneath the ends of said inlay member. 45

DAVID KARRON.