

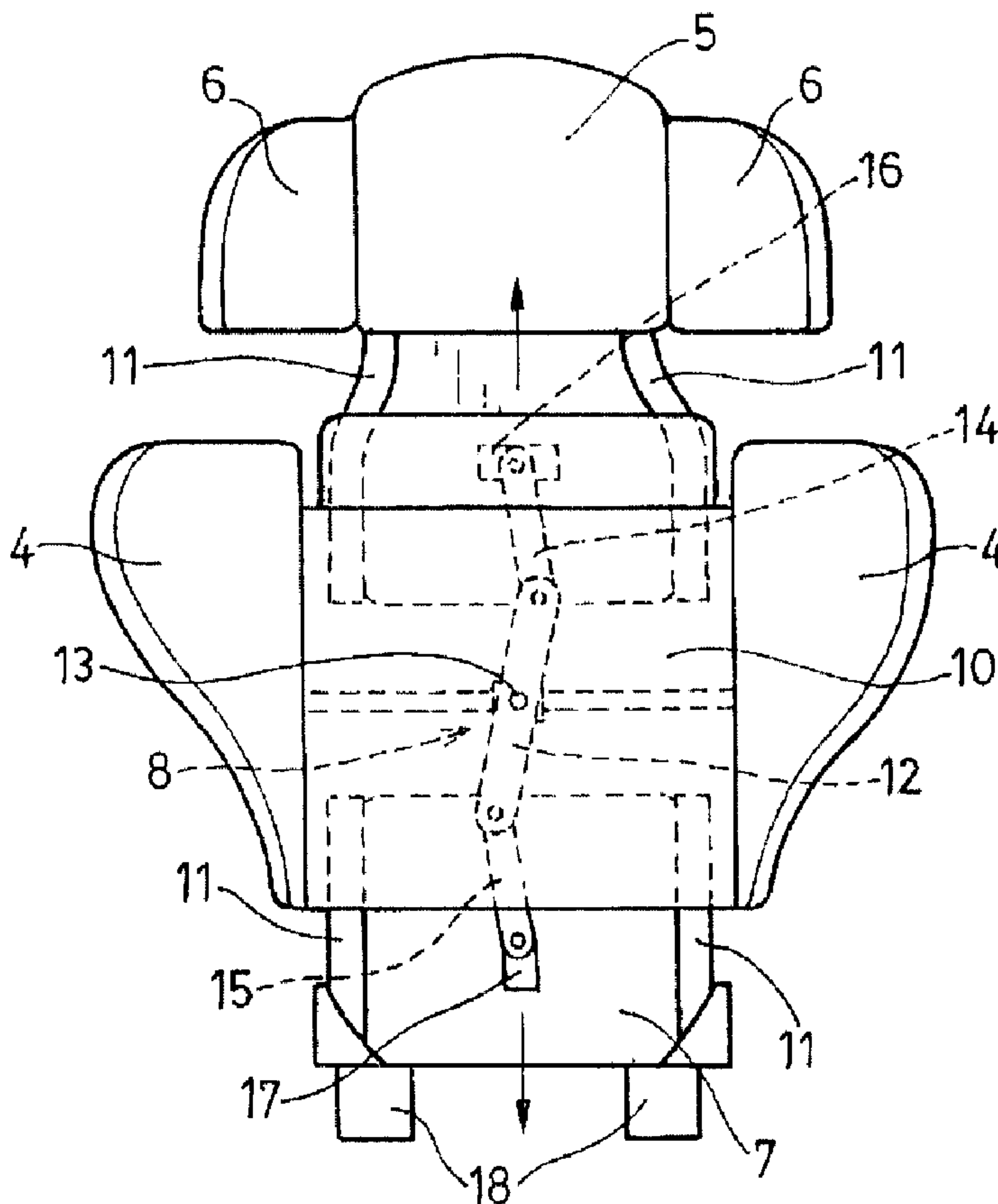

(22) Date de dépôt/Filing Date: 2007/06/14  
 (41) Mise à la disp. pub./Open to Public Insp.: 2007/12/30  
 (45) Date de délivrance/Issue Date: 2013/08/20  
 (30) Priorité/Priority: 2006/06/30 (ES ES 200601557 U)

(51) Cl.Int./Int.Cl. *B60N 2/28* (2006.01),  
*B60N 2/02* (2006.01)  
 (72) Inventeur/Inventor:  
JANE SANTAMARIA, MANUEL, ES  
 (73) Propriétaire/Owner:  
JANE, S.A., ES  
 (74) Agent: RICHES, MCKENZIE & HERBERT LLP

(54) Titre : SIEGE D'AUTO POUR BEBE  
 (54) Title: AN INFANT SEAT FOR MOTORCARS



(57) Abrégé/Abstract:

The very seat itself (1) comprises a backrest (3) with lateral protections (4), and a liftable headrest (5). This infant seat is characterised in that the backrest is inferiorly provided with a complementary member (7) being linked to the headrest (5) by means



**(57) Abrégé(suite)/Abstract(continued):**

of a mechanism (8) that when lifting (F) the headrest brings about a downwardly shifting motion (F') of the complementary member (7) of the backrest. The aforementioned mechanism (8) is arranged between a rear plate (9) and a front plate (10) making up the backrest, the headrest (5) and the complementary member (7) of the backrest having guiding elements (11) for their shifting between said two plates (9 and 10) . The aforementioned mechanism comprises an element (12) being rotatably secured at its centre (13) and having a respective link (14 and 15) fitted to each of its ends, said links being respectively linked to the headrest (5) and to the complementary member (7) of the backrest.

**ABSTRACT**

The very seat itself (1) comprises a backrest (3) with lateral protections (4), and a liftable headrest (5). This infant seat is characterised in that the backrest is inferiorly provided with a complementary member (7) being linked to the headrest (5) by means of a mechanism (8) that when lifting (F) the headrest brings about a downwardly shifting motion (F') of the complementary member (7) of the backrest. The aforementioned mechanism (8) is arranged between a rear plate (9) and a front plate (10) making up the backrest, the headrest (5) and the complementary member (7) of the backrest having guiding elements (11) for their shifting between said two plates (9 and 10). The aforementioned mechanism comprises an element (12) being rotatably secured at its centre (13) and having a respective link (14 and 15) fitted to each of its ends, said links being respectively linked to the headrest (5) and to the complementary member (7) of the backrest.

An infant seat for motorcars.

#### FIELD OF THE INVENTION

5           The seats of this kind are generally meant to be installed on the rear seats of the motorcars for the children's safety.

#### BACKGROUND OF THE INVENTION

10           These infant seats comprise the very seat itself, a backrest with lateral protections, and a liftable headrest being also generally provided with lateral protections, said infant seats being designed for children of different ages, particularly for those of more than one year of age.

15           The headrest forms a separate piece being adapted to be fitted to the backrest in an upwardly shiftable arrangement in order to thus be in a position to be adapted to the child's height and to thus still protect this latter's head, the lateral protections of the  
20 backrest nevertheless remaining in a stationary arrangement and hence not properly fulfilling their function because their low position does not offer an adequate protection for the lateral shifting motions of the child such as those possibly occurring during the  
25 sudden changes of direction of the motorcar, for example.

#### SUMMARY OF THE INVENTION

          In order to solve this problem the infant seat being the object of this invention has been devised wherein the lateral protections of the backrest are also lifted with  
30 respect to the very seat itself when lifting the headrest.

          In order to achieve this improvement the backrest is inferiorly provided with a complementary member being linked to the headrest by means of a mechanism that when  
35 lifting the headrest brings about a downwardly shifting

motion of the complementary member of the backrest and thus results in having the lateral protections of the backrest arranged in a more elevated arrangement with respect to the very seat itself.

The aforementioned mechanism is arranged between a rear plate and a front plate making up the backrest, the headrest and the complementary member of the backrest having guiding elements for their shifting between said two plates. This mechanism comprises an element being rotatably secured at its centre and having a respective link fitted to each of its ends, said links being respectively linked to the headrest and to the lower complementary member of the backrest.

Accordingly, in one aspect the present invention resides in the infant seat for motorcars, which comprises the seat, a backrest with lateral protections and a liftable headrest with lateral protections as well, the backrest inferiorly showing a complementary member being linked to the headrest by means of a mechanism that when lifting (F) the headrest brings about a downwardly shifting motion (F') of the complementary member of the backrest, wherein the mechanism is arranged between a rear plate and a front plate making up the backrest, the headrest and the complementary member of the backrest having guiding elements for shifting the headrest and the complementary member between said two plates, the mechanism comprising an element being rotatably secured at a centre and having a respective link fitted to each end of the element said links being respectively linked to the headrest and to the complementary member of the backrest.

These and other characterising features will be best made apparent by the following detailed description whose understanding will be made easier by the accompanying two sheets of drawings showing a practical embodiment being cited only by way of example not limiting the scope of the present invention.

#### DESCRIPTION OF THE DRAWINGS

In the drawings:

Figs. 1 and 2 diagrammatically depict in a side elevation an infant seat of the conventional type with its headrest in a lowered and in a lifted position, respectively;

Fig. 3 diagrammatically depicts in a side elevation the infant seat being the object of the invention showing the lifted position being assumed by the lateral protections of the backrest when lifting the headrest;

Fig. 4 diagrammatically illustrates in a perspective view the backrest-headrest assembly pertaining to the infant seat in question; and

Figs. 5 and 6 diagrammatically show in a front elevation the aforementioned backrest-headrest assembly 35 in a lowered and in a lifted position, respectively.

## DETAILED DESCRIPTION

The infant seats (A) (Fig. 1) of this kind comprise the very seat itself (1) with armrests (2) to which a backrest (3) with lateral protections (4) is articulately fitted, a headrest (5) also with lateral protections (6) being fitted to said backrest in a slidable arrangement so as to thus be in a position to be lifted as shown in Fig. 2. As can be seen in this figure, as the child grows its head is as well protected, the lateral protections (4) of the backrest nevertheless remaining in a low position and thereby not offering a correct protection for the child during its possible lateral shifting motions.

This drawback has now been obviated with the infant seat (A') being the object of this invention wherein in Fig. 3 it can be seen how the lateral protections (4) of the backrest also assume a more elevated position when lifting the headrest (5).

In order to achieve these elevations the backrest is inferiorly provided with a complementary member (7) being linked to the headrest (5) by means of a mechanism (8) that when lifting the headrest as per arrow F brings about the downwardly shifting motion as per arrow F' of the complementary member (7) of the backrest, the lateral protections (4) of this latter being thus arranged in a more elevated arrangement with respect to the very seat (1) itself.

The aforementioned mechanism (8) is arranged between a rear plate (9) and a front plate (10) making up the backrest, the headrest (5) and the complementary member (7) of the backrest having guiding elements (11) for their shifting between said two plates.

The aforementioned mechanism (8) in this case comprises an element being formed by a flat (12) being rotatably fitted at its centre (13) to a pin being

secured to the plate (10), the flat (12) having fitted to each of its ends a respective one of two links (14) and (15) being linked by means of respective fixtures (16) and (17) to the headrest (5) and to the complementary member (7) of the backrest, respectively. This mechanism can be replaced with another one allowing to have the headrest (5) and the complementary member (7) of the backrest linked to each other in the above manner.

The aforementioned complementary member (7) is made up by a plate at its lower edge comprising couplings (18) for removably and articulately fitting the backrest to the seat (1).

Both the backrest and the headrest can have their lateral protections (4) and (6) provided with a mechanism being fit to adjust their separation in order to adapt it to the child's width.

We claim:

1 The infant seat for motorcars, which comprises the seat (1), a backrest (3) with lateral protections (4) and a liftable headrest (5) with lateral protections (6) as well, the backrest inferiorly showing a complementary member (7) being linked to the headrest (5) by means of a mechanism (8) that when lifting (F) the headrest brings about a downwardly shifting motion (F') of the complementary member (7) of the backrest, wherein the mechanism (8) is arranged between a rear plate (9) and a front plate (10) making up the backrest, the headrest (5) and the complementary member (7) of the backrest having guiding elements (11) for shifting the headrest and the complementary member between said two plates (9, 10), the mechanism (8) comprising an element (12) being rotatably secured at a centre (13) and having a respective link (14, 15) fitted to each end of the element (12), said links being respectively linked to the headrest (5) and to the complementary member (7) of the backrest.

2 The infant seat for motorcars, according to claim 1, characterized in the lateral protections (4) of the backrest and the lateral protections (6) of the headrest are provided with an adjustment mechanism for adjusting a separation between the projections in order to adapt it to a child's width.

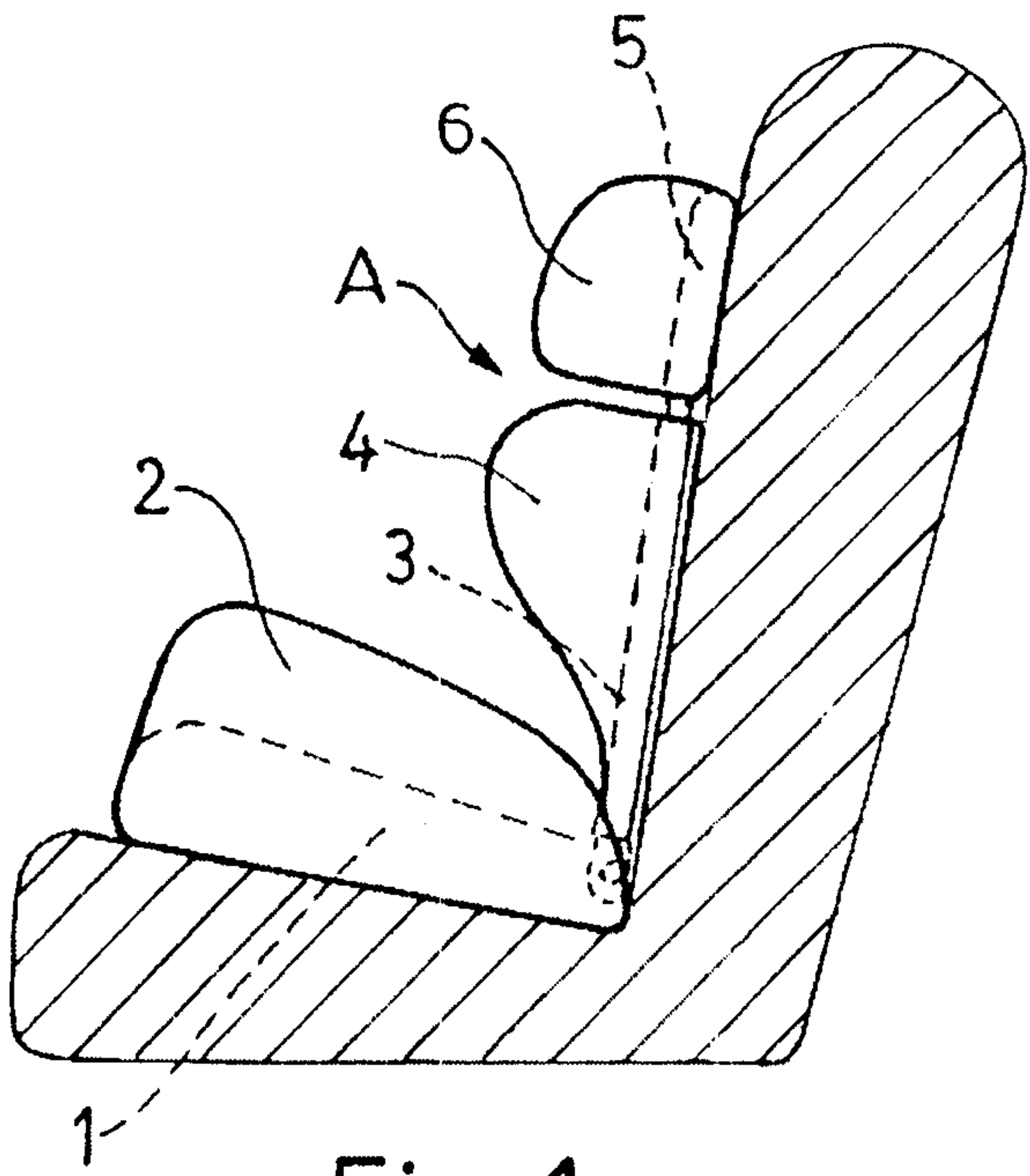

Fig. 1

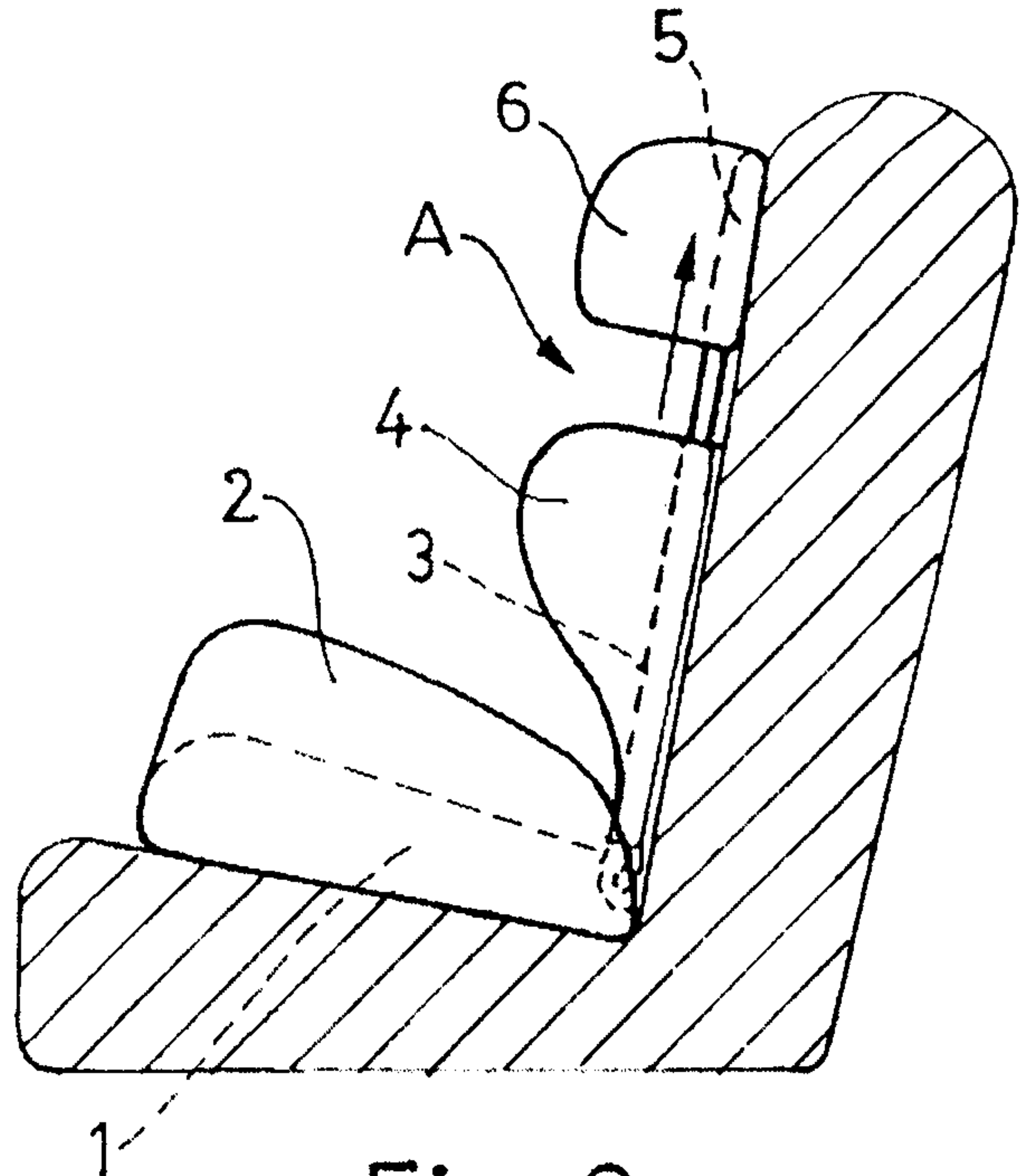

Fig. 2

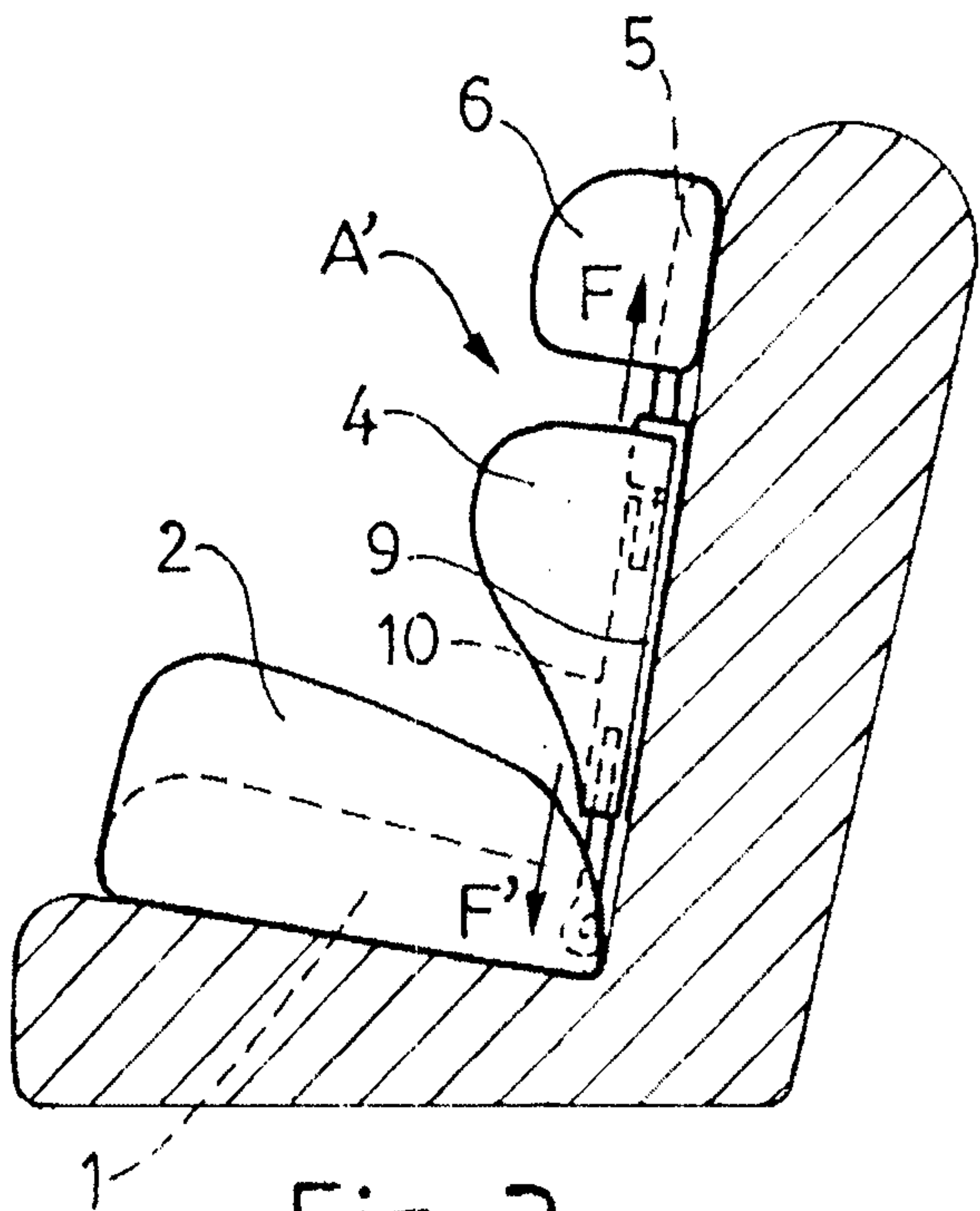

Fig. 3

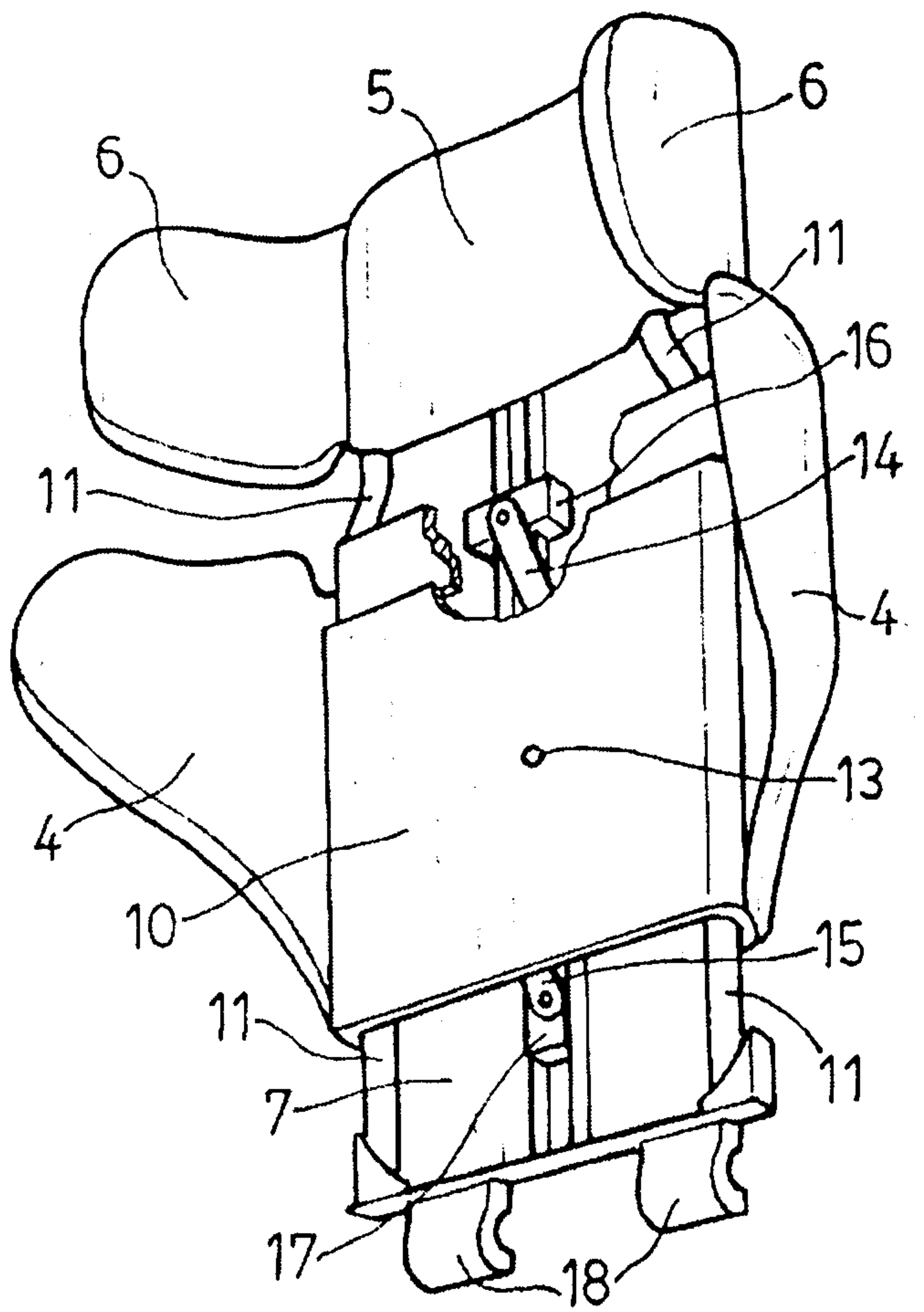

Fig. 4

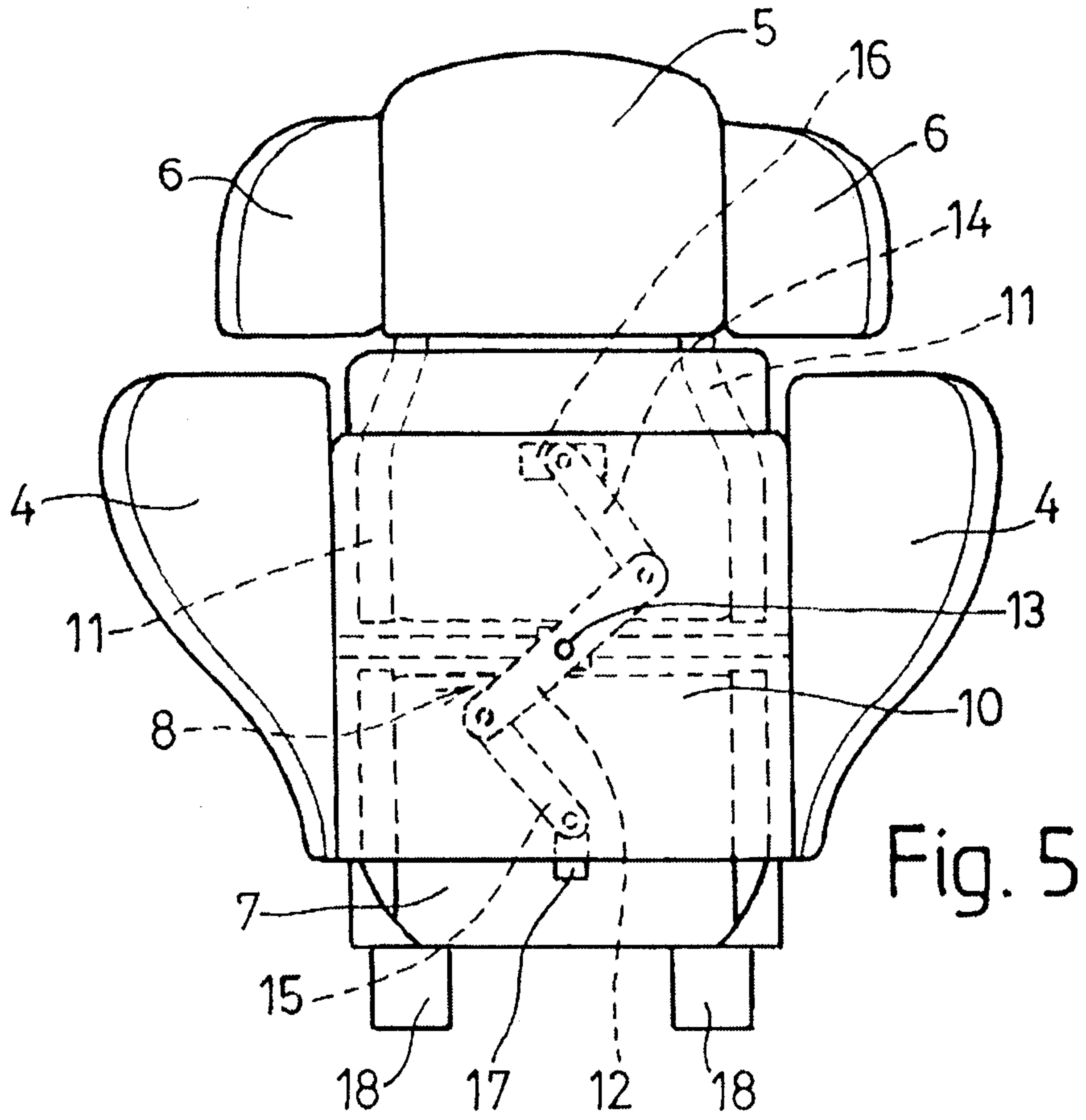

Fig. 5

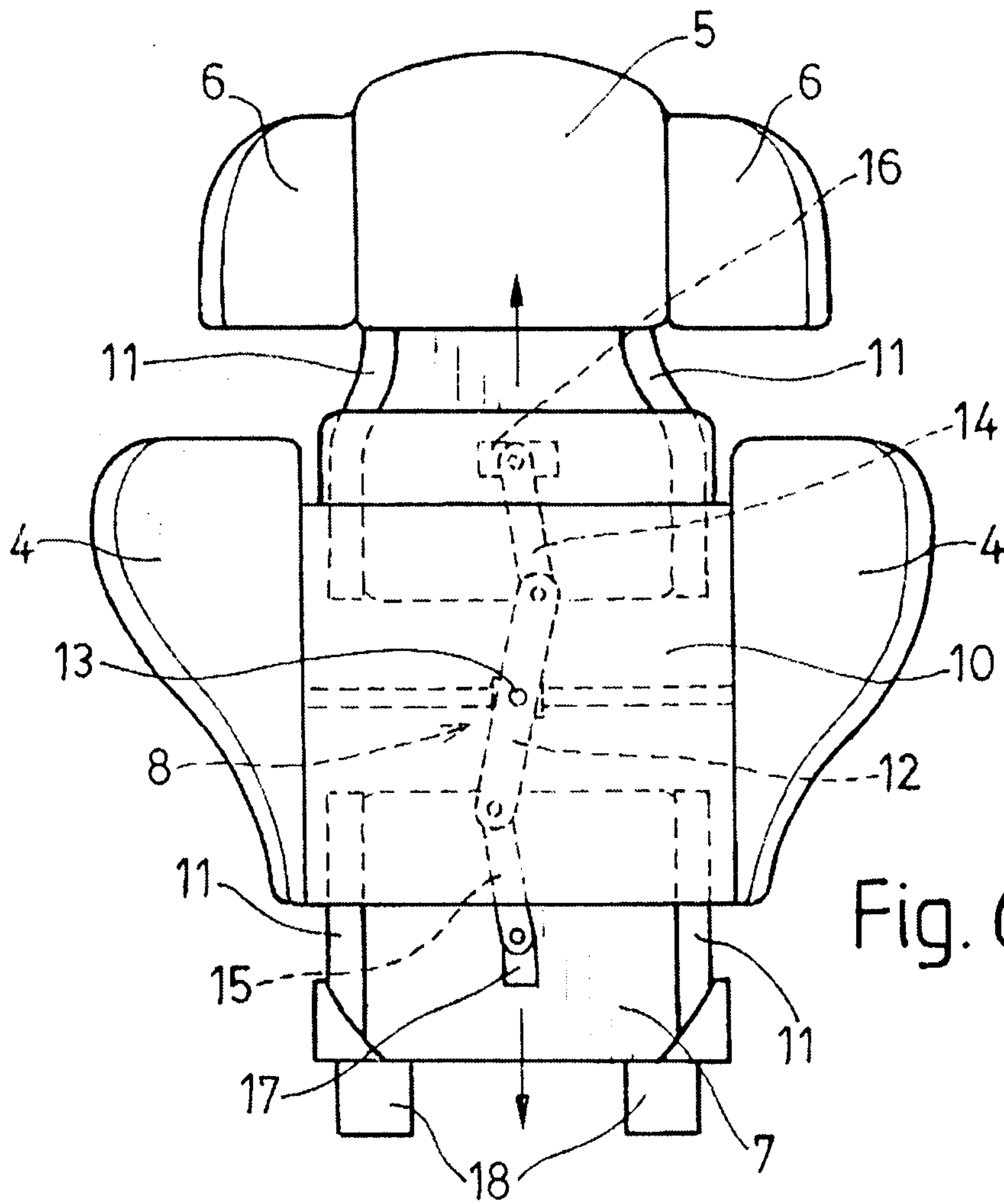

Fig. 6

