

(No Model.)

J. P. HUNTER.
LUBRICATOR.

No. 526,838.

Patented Oct. 2, 1894.

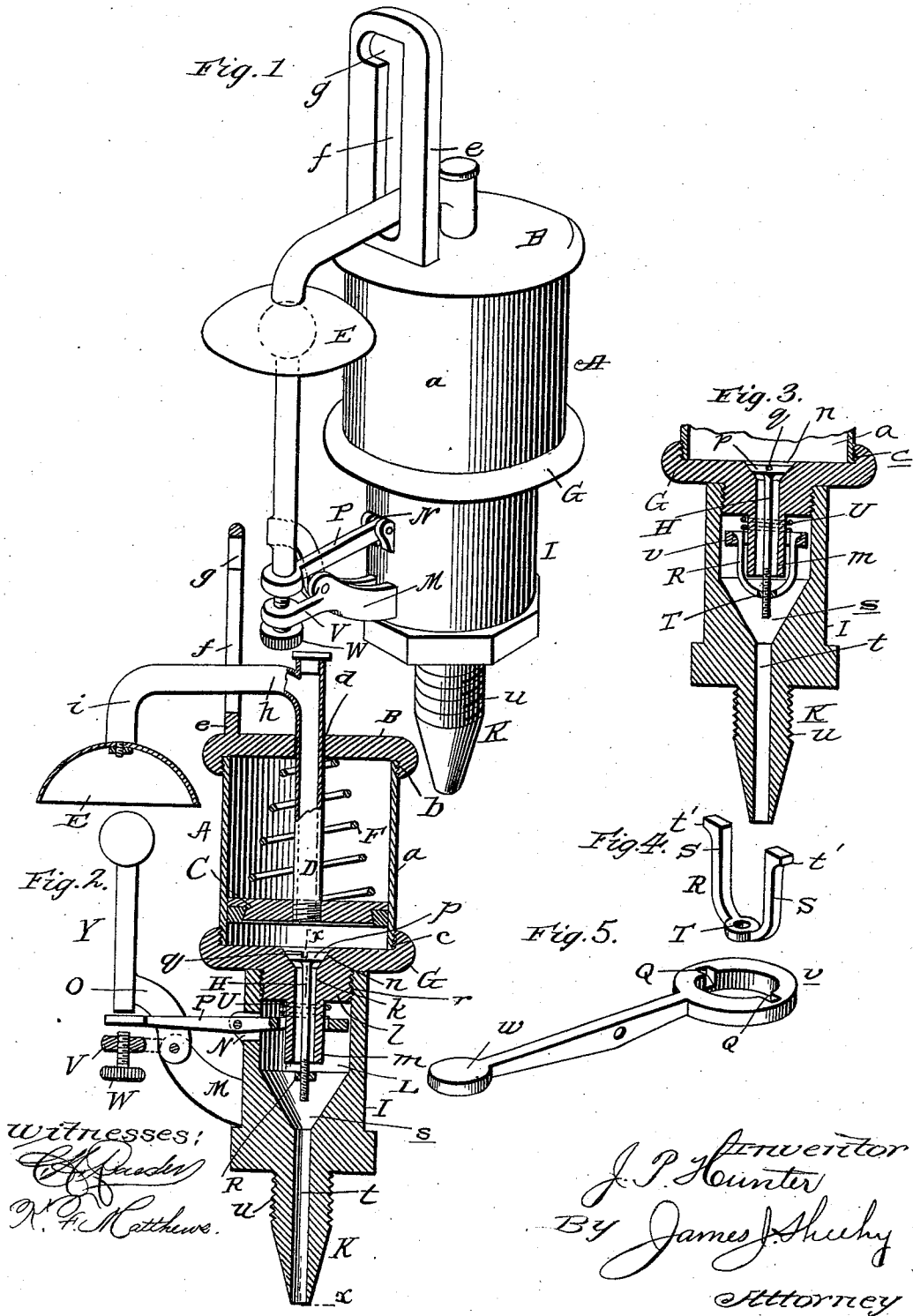

UNITED STATES PATENT OFFICE.

JOHN P. HUNTER, OF BOISE CITY, ASSIGNOR OF ONE-HALF TO THOMAS GRACIA, OF QUARTZBURG, IDAHO.

LUBRICATOR.

SPECIFICATION forming part of Letters Patent No. 526,838, dated October 2, 1894.

Application filed July 14, 1894. Serial No. 517,586. (No model.)

To all whom it may concern:

Be it known that I, JOHN P. HUNTER, a citizen of the United States, residing at Boise City, in the county of Ada and State of Idaho, have invented certain new and useful Improvements in Oil-Cups for Steam-Engines; and I do declare the following to be a full, clear, and exact description of the invention, such as will enable others skilled in the art to which it appertains to make and use the same.

This invention has relation to improvements in devices for holding oil, grease, and other lubricants, and feeding the same under pressure to the moving parts of machinery, and is more particularly adapted to be applied to the crank pin and cross head of a steam engine.

The many objects and advantages will appear from the following description and claims when taken in connection with the annexed drawings, in which—

Figure 1, is a perspective view of the improved device illustrating the parts in the position which they assume when all or a greater part of the lubricant has been expelled from the cup. Fig. 2, is a vertical, central, sectional view of the same. Fig. 3, is a vertical, sectional view taken in the plane indicated by the dotted line x, x , on Fig. 2, with a part of the cup broken away. Fig. 4, is a perspective view of the stirrup for receiving the screw valve, and Fig. 5, is a perspective view of the lever for sustaining the stirrup and operating the bell hammer.

Referring by letter to said drawings: A, indicates the cup for holding the oil, grease, or other lubricant. This cup may be of any suitable capacity and composed of any suitable material, having a cylindrical body a , which is externally screw threaded at opposite ends as shown at b , and c .

The upper end of the cup is closed by a screw cap B, having a central aperture d , and is also provided with a post or upright e , which may be formed integral with the cap or composed of a separate piece and fixed thereto. This upright is slotted longitudinally as shown at f , and at the upper end of the vertical slot is a notch or offset recess g .

Within the cup is a snugly fitting piston C,

which has secured to it a vertically-disposed hollow stem D, which may be connected by a screw joint, or otherwise. This stem passes out through the aperture d , in the screw cap of the cup and is curved laterally as shown at h , to pass through the vertical slot of the upright e , and thence curves downwardly as shown at i , to receive on its free end, a gong or bell E. Said stem is open at the upper end of its vertical branch to provide a filling aperture and said aperture is normally closed by a stopper as shown.

Interposed between the upper side of the piston C, within the cup, and the under side of the screw cap, is a spring F, which is here shown as of a conical form so that it may nest when fully contracted, although it is obvious that other forms of springs might be used.

The bottom of the cup is covered by a disk or plate G, which is also screw threaded to receive the screw thread c , of the cup, and this plate is provided with a central, vertical aperture k , and surrounding the aperture on the under side is an externally threaded boss l , and depending centrally from this boss is a tube m ; the aperture extending through the boss and tube, as shown. The aperture k , through the bottom of the cup is countersunk or provided with a concavity n , at its upper end, so as to receive the conical head p , of the screw valve H, arranged therein. This valve may comprise an ordinary screw having a kerf q , to receive a screw driver or other implement for adjusting it so as to regulate the discharge of the feed.

I, indicates a nozzle or base section. This nozzle is screw tapped at its upper end as shown at r , and is designed to be screwed on to the threaded boss l , of the plate G, and is provided at its lower end with a discharge nipple K. The chamber L, of the nozzle, extends for a sufficient distance and is then provided with a conical base s , from the center of which the discharge passage or aperture t , extends out through the discharge nipple, and the nipple is externally screw threaded as shown at u , so that it may be screwed on to the crank pin or cross head of an engine or other suitable part of machinery to be lubricated. The nozzle is provided at

one side with a lateral bracket M, which may be formed integral therewith and above this bracket arm is a lateral slot N.

P, indicates a lever. This lever is of a peculiar construction having a ring *v*, at its inner end which is designed to surround the tube *m*, and it is provided at its outer end with a flat head *w*, for a purpose which will presently appear. The lever is pivoted at a suitable point in its length in the lateral aperture N, as shown, and the ring is provided at diametrically opposite points with notches or seats Q, to receive the stirrup R. This yoke R, has its two branches S, provided at their free ends with lateral lugs *t*, to bear in the notches Q, of the ring of the lever P, and said yoke is provided in its vertical center with a screw tapped aperture T, which is designed to receive the screw threads of the valve H. It will thus be seen that the valve can be adjusted in the outlet aperture of the cup.

U, indicates a spring which may surround the tube *m*, and bears at opposite ends against the boss and the upper side of the inner end of the lever P, so that it will tend to depress said lever at the inner end and consequently the stirrup carried thereby which supports the valve.

Extending horizontally from the bracket arm M, is a branch V, which is screw tapped to receive the threaded stem of a set screw W, and this branch and set screw assume a position below the flattened head of the lever P.

Y, indicates a bell hammer. This hammer is provided at its upper end with a suitable head, and its lower end is pivotally connected with the bracket arm M, preferably by means of a curved arm O, and the lower end of said hammer is designed to come into contact and rest upon the outer end of the lever P, and said hammer is arranged just below the bell or gong E.

In operation, it will be seen that by taking hold of the stem of the plunger, and drawing it up in the slot *f*, of the upright until it reaches the offset *g*, the spring F, within the oil cup will be contracted, and the plunger can then be removed by simply screwing off the cap B. When the cap has been removed, should it be desirable to adjust the valve H, so as to change the discharge of the lubricant, this can be done very quickly by the manipulation of a screw driver or other implement placed in the kerf of said valve. The grease or oil should then be placed in the cup and the screw cap replaced, and the stem of the plunger taken out of the offset in the upright when the spring F, will be allowed to act and will force the grease or oil down around the valve and out through the discharge until all of the contents have been expelled. At this point or just before all of the lubricant has been discharged, the bell or gong descending, will come in contact with the hammer, and as the motion of the engine will keep the hammer vibrating, an alarm

will be given to the attendant, and the bell or gong will continue to ring until the piston has been raised in the cup. By reason of the set screw W, the hammer can be raised or lowered with respect to the bell or gong so as to adjust the same for action, and by reason of the spring U, the lever although seated upon the set screw at its outer end, and the hammer bearing thereon, it will effectively cause a vibration of said lever during the movements of the engine, and will consequently impart such vibratory motion to the hammer.

While I have given a very full and detailed description of the various parts, and the exact manner in which they are combined and connected, yet I do not wish to be understood as confining myself to the exact construction and combinations shown and set forth, as I am aware that many of them might be modified without departing from the spirit of my invention.

Having described my invention, what I claim is—

1. In a forced feed lubricator, the combination with a cup, having a suitable discharge; of a piston movable in said cup, and having a stem, a gong carried by said stem and a hammer in the path of movement of said gong, the hammer and gong being designed to contact as the lubricant has been discharged from the cup, substantially as specified.

2. In a forced feed lubricator, the combination with a cup having a discharge aperture in its bottom, in combination with a spring backed plunger arranged in the cup, and having a stem carrying a gong or alarm device at its outer end, a hammer arranged in the path of said gong, and a pivoted lever backing said hammer whereby an alarm will be given when the piston descends in the cup, substantially as specified.

3. In a forced feed lubricator, the combination with a cup, having a discharge aperture in its bottom; of the nozzle, the lever pivoted in said nozzle, the yoke carried by the lever, the valve adjustably secured in the yoke, the spring interposed between the bottom of the cup and the lever, the hammer arranged to contact with the outer end of said lever, and the piston having a stem carrying a gong or the like arranged to move in the plane of the hammer, substantially as specified.

4. In a forced feed lubricator, the combination with a suitable cup; of a piston having a stem carrying a gong or the like, the nozzle secured to the cup, the bracket arm on the nozzle having the screw threaded branch, the set screw arranged therein, the pivoted lever, in the nozzle of the cup and the hammer arranged above the outer end of the lever so as to contact therewith, substantially as specified.

5. The improved device described comprising the cup having the discharge aperture in

its bottom and the screw cap having the slot-
ted upright, the bottom having the threaded
boss and the tube depending therefrom, the
nozzle screwed on to the boss, and also
5 threaded to be secured to the crank pin or
cross head of an engine, the lever pivoted in
one of the walls of the nozzle and having a
ring at its inner end to surround the tube and
also having diametrically disposed notches in
10 the ring, the yoke arranged in the notches of
the ring and having the screw threaded ap-
erture, the threaded valve arranged in the
stirrup, the pivoted hammer, the setscrew ar-
ranged below the hammer, the plunger ar-
15 ranged in the oil cup, and having its stem
passing through the slot of the upright and
carrying a gong at its outer end, and the
spring arranged in the cup above the plun-

ger, all combined and adapted to operate,
substantially as specified. 20

6. The combination with the nozzle; of the
lever pivoted therein and having a ring at
its inner end, the yoke suspended from said
ring and having a threaded aperture, the
valve having a threaded stem and adjustably 25
secured in said yoke, a vibratory hammer ar-
ranged to contact with the outer end of the
lever, the plunger and the gong thereon sub-
stantially as and for the purpose specified.

In testimony whereof I affix my signature in 30
presence of two witnesses.

JOHN P. HUNTER.

Witnesses:

TOM MYER,
HUGH GARDNER.