

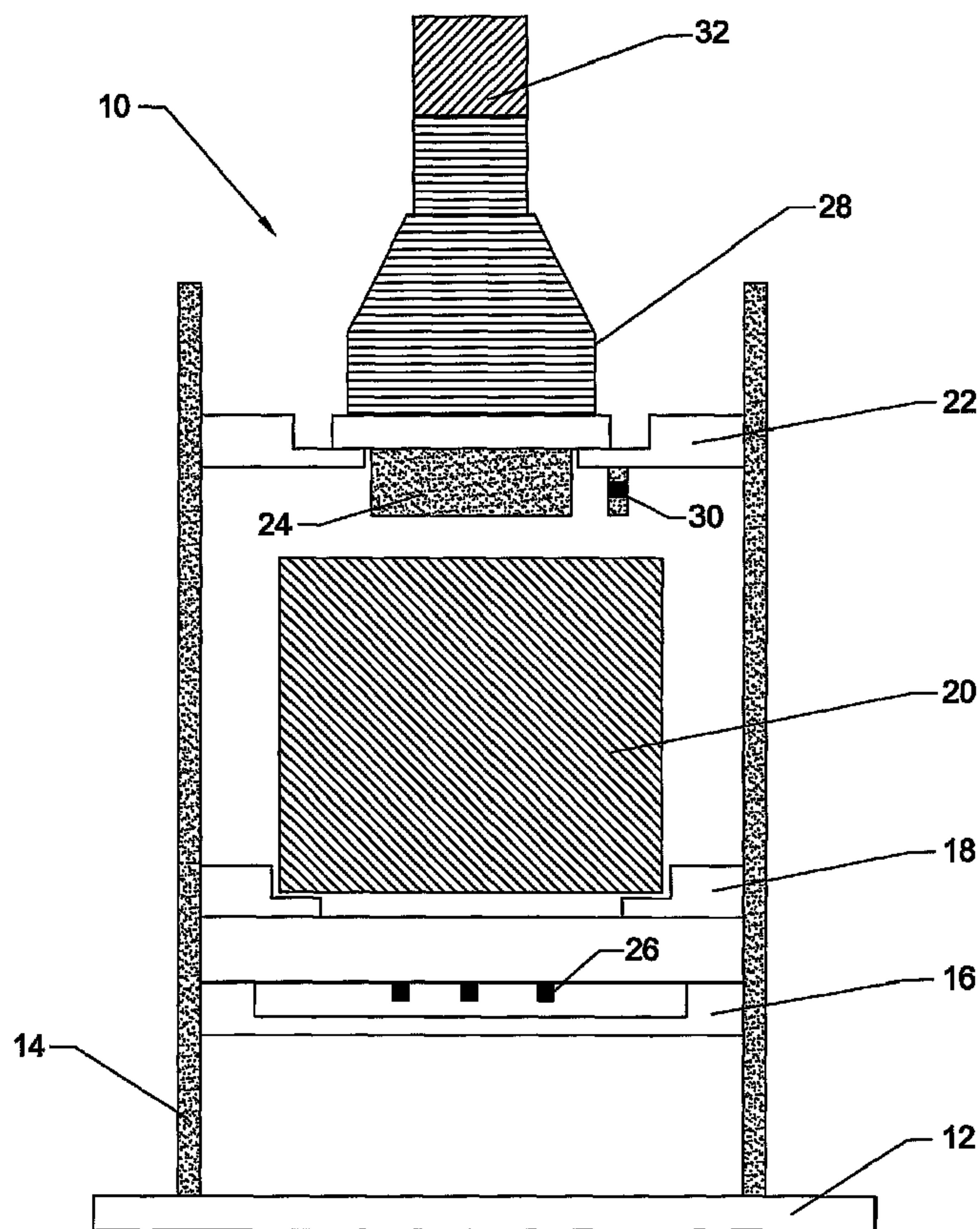

(86) Date de dépôt PCT/PCT Filing Date: 2001/06/01  
 (87) Date publication PCT/PCT Publication Date: 2002/01/10  
 (45) Date de délivrance/Issue Date: 2007/08/21  
 (85) Entrée phase nationale/National Entry: 2002/12/20  
 (86) N° demande PCT/PCT Application No.: US 2001/017706  
 (87) N° publication PCT/PCT Publication No.: 2002/003055  
 (30) Priorité/Priority: 2000/06/29 (US09/606,645)

(51) Cl.Int./Int.Cl. *G01N 23/08* (2006.01)  
 (72) Inventeurs/Inventors:  
 DEP, W. LINUS, US;  
 TROXLER, ROBERT E., US  
 (73) Propriétaire/Owner:  
 TROXLER ELECTRONIC LABORATORIES, INC., US  
 (74) Agent: SIM & MCBURNEY

(54) Titre : APPAREIL ET PROCEDE PERMETTANT DE DETERMINER LES RAYONS GAMMA DU POIDS VOLUMIQUE APPARENT D'UN ECHANTILLON  
 (54) Title: APPARATUS AND METHOD FOR GAMMA-RAY DETERMINATION OF BULK DENSITY OF SAMPLES



(57) Abrégé/Abstract:

A nuclear density gauge and test method is provided for measuring bulk density, especially of a cylindrically shaped sample such as asphalt paving material. The gauge comprises a base (12); a sample holder (18) carried by the base and having a surface

(57) **Abrégé(suite)/Abstract(continued):**

configured for receiving and holding a first generally planar end of the cylindrically shaped sample (20); a plate (16) mounted in proximity to said sample holder; and at least three sources of gamma radiation located in said plate adjacent the sample holder. The sources (26) are positioned in spaced-apart relation from one another for emitting gamma radiation from at least three spaced-apart locations into said one end of the sample. Each of the sources comprises an isotope having a characteristic primary energy. A detector is mounted to the base and is positioned adjacent the opposite end of the cylindrically shaped sample for receiving gamma radiation which has penetrated the sample. Means is provided cooperating with the detector for calculating the bulk density of the sample based upon the gamma radiation counts by the detector. Preferably the detector comprises a scintillation detector (24), and the means for calculating the bulk density of the sample includes an analyzer connected to the scintillation detector for detecting gamma radiation in a predetermined energy spectrum, which preferably falls within the range of 0.1 MeV to 2 MeV.

## (12) INTERNATIONAL APPLICATION PUBLISHED UNDER THE PATENT COOPERATION TREATY (PCT)

(19) World Intellectual Property Organization  
International Bureau(43) International Publication Date  
10 January 2002 (10.01.2002)

PCT

(10) International Publication Number  
WO 02/03055 A3(51) International Patent Classification<sup>7</sup>: G01N 23/10[LK/US]; 105 Kenilworth Place, Chapel Hill, NC 27516 (US). **TROXLER, Robert, E.** [US/US]; 3218 Sussex Road, Raleigh, NC 27605 (US).

(21) International Application Number: PCT/US01/17706

(22) International Filing Date: 1 June 2001 (01.06.2001)

(74) Agents: **LINKER, Raymond, O., Jr.** et al.: Alston & Bird LLP, Bank of America Plaza, Suite 4000, 101 South Tryon Street, Charlotte, NC 28280-4000 (US).

(25) Filing Language: English

(26) Publication Language: English

(30) Priority Data:  
09/606.645 29 June 2000 (29.06.2000) US(81) Designated States (*national*): AE, AG, AL, AM, AT, AU, AZ, BA, BB, BG, BR, BY, BZ, CA, CH, CN, CO, CR, CU, CZ, DE, DK, DM, DZ, EC, EE, ES, FI, GB, GD, GE, GH, GM, HR, HU, ID, IL, IN, IS, JP, KE, KG, KP, KR, KZ, LC, LK, LR, LS, LT, LU, LV, MA, MD, MG, MK, MN, MW, MX, MZ, NO, NZ, PL, PT, RO, RU, SD, SE, SG, SI, SK, SL, TJ, TM, TR, TT, TZ, UA, UG, US, UZ, VN, YU, ZA, ZW.(71) Applicant (*for all designated States except US*): **TROXLER ELECTRONIC LABORATORIES, INC.** [US/US]; 3008 Cornwallis Road, Research Triangle Park, NC 27709 (US).

(72) Inventors; and

(75) Inventors/Applicants (*for US only*): **DEP, W., Linus**(84) Designated States (*regional*): ARIPO patent (GH, GM, KE, LS, MW, MZ, SD, SL, SZ, TZ, UG, ZW), Eurasian patent (AM, AZ, BY, KG, KZ, MD, RU, TJ, TM), European patent (AT, BE, CH, CY, DE, DK, ES, FI, FR, GB, GR, IE).

[Continued on next page]

(54) Title: APPARATUS AND METHOD FOR GAMMA-RAY DETERMINATION OF BULK DENSITY OF SAMPLES

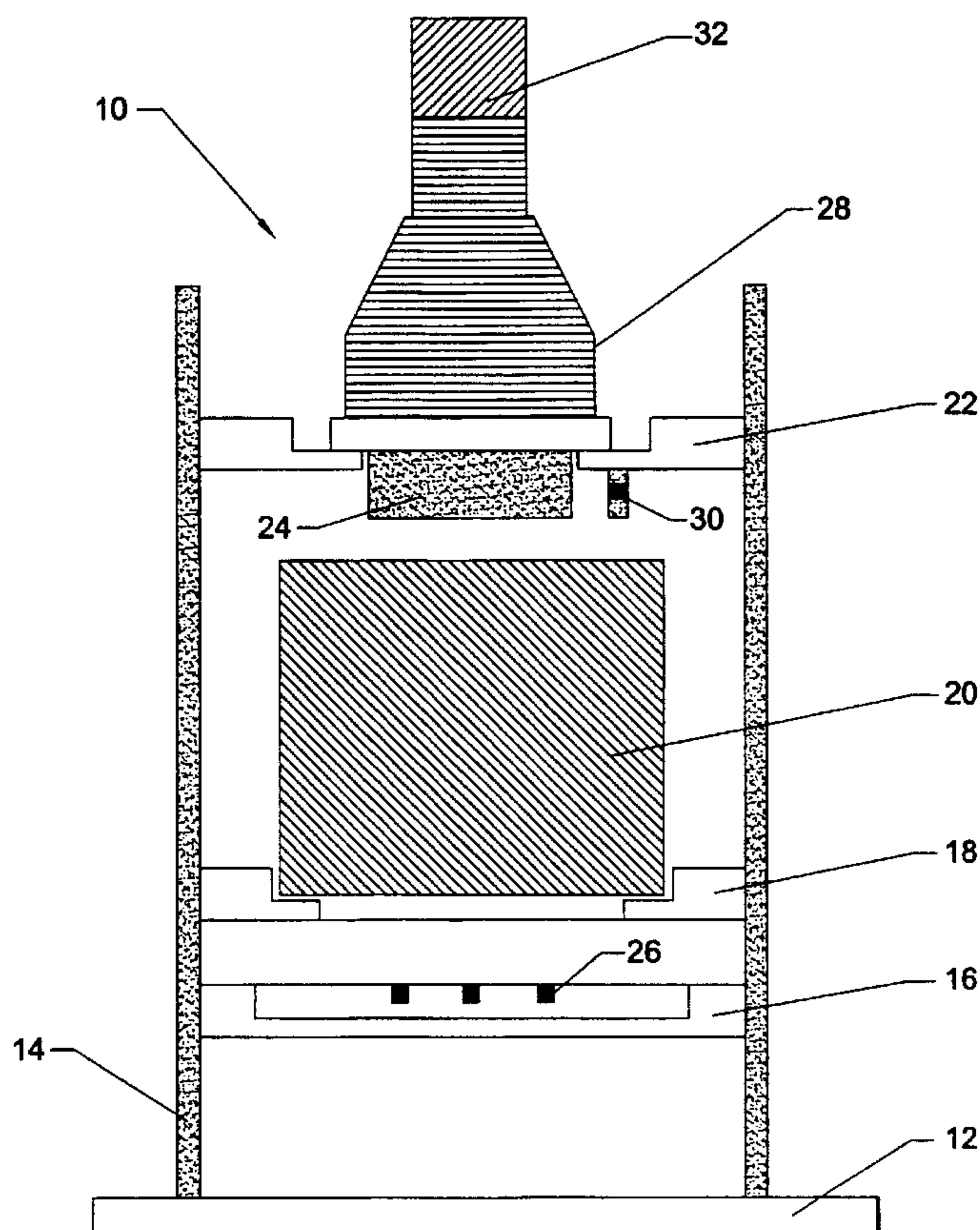

(57) **Abstract:** A nuclear density gauge and test method is provided for measuring bulk density, especially of a cylindrically shaped sample such as asphalt paving material. The gauge comprises a base (12); a sample holder (18) carried by the base and having a surface configured for receiving and holding a first generally planar end of the cylindrically shaped sample (20); a plate (16) mounted in proximity to said sample holder; and at least three sources of gamma radiation located in said plate adjacent the sample holder. The sources (26) are positioned in spaced-apart relation from one another for emitting gamma radiation from at least three spaced-apart locations into said one end of the sample. Each of the sources comprises an isotope having a characteristic primary energy. A detector is mounted to the base and is positioned adjacent the opposite end of the cylindrically shaped sample for receiving gamma radiation which has penetrated the sample. Means is provided cooperating with the detector for calculating the bulk density of the sample based upon the gamma radiation counts by the detector. Preferably the detector comprises a scintillation detector (24), and the means for calculating the bulk density of the sample includes an analyzer connected to the scintillation detector for detecting gamma radiation in a predetermined energy spectrum, which preferably falls within the range of 0.1 MeV to 2 MeV.

WO 02/03055 A3

**WO 02/03055 A3**



IT, LU, MC, NL, PT, SE, TR), OAPI patent (BF, BJ, CF, CG, CI, CM, GA, GN, GW, ML, MR, NE, SN, TD, TG).

**(88) Date of publication of the international search report:**

2 May 2002

**Published:**

- *with international search report*
- *before the expiration of the time limit for amending the claims and to be republished in the event of receipt of amendments*

*For two-letter codes and other abbreviations, refer to the "Guidance Notes on Codes and Abbreviations" appearing at the beginning of each regular issue of the PCT Gazette.*

## APPARATUS AND METHOD FOR GAMMA-RAY DETERMINATION OF BULK DENSITY OF SAMPLES

### FIELD OF THE INVENTION

This invention relates to the measurement of bulk density, and more particularly to an apparatus and method for measuring the bulk density of a sample using gamma radiation. The invention is especially suited for measuring the bulk density of relatively small "finite volume" samples, and in particular, cylindrically shaped samples such as core samples or gyratory compacted specimens of asphalt paving material.

### BACKGROUND OF THE INVENTION

In the asphalt pavement construction industry, the cylinder is a common sample geometry. In laboratories, cylindrical samples are prepared, typically with a gyratory compactor, and various material properties are studied to determine the best mix design for a pavement. In the field, cylindrical samples are cored from test strips, newly constructed roads, or existing roads. The material properties of these samples are then used to evaluate whether the test strip or the new pavement meets the design criteria and whether the existing road is in good operating condition or in need of repairs. Among the material properties studied in the cylindrical asphalt samples, material bulk density or bulk specific gravity is an important property.

Currently, several methods are used for measuring the density of cylindrical samples: dimensional analysis, the water displacement method, the paraffin coated method, and the para-film-covered method. In each case, the bulk density of a sample is derived by, as in the definition, dividing the dry sample mass by the

estimated sample volume. All methods require a balance with a sensitivity of 0.1 g. to measure the mass of the sample. In the dimensional analysis method, sample volume is determined from the radius and thickness (height) measurements. Here, many readings of the radius and thickness of the sample are made using a vernier  
5 caliper. The average values of the radius and the thickness are then used to calculate the sample volume. The other methods use the Archimedes Principle for determining the sample volume. These methods require a large container filled with clean water. The water temperature should be monitored and controlled at a specific temperature, e.g. at 25°C. At one stage of the test, the sample is kept  
10 immersed in water for approximately 4 minutes and the weight of the sample, while suspended in water, is recorded. In the "paraffin-coated" method, after determining the dry weight of the sample, a thin coating of paraffin is applied to cover the entire surface area of the sample. Then, the sample is weighed again in air. Finally, the sample is weighed while immersed in water. The "parafilm-  
15 covered" method is similar to the "paraffin-coated" method, except that a film is used to wrap the sample. The water displacement test, which is the fastest of all three Archimedes methods, takes about 6 minutes. The single operator precision of the water displacement method is 0.0124 g/cm<sup>3</sup> and the paraffin-coated method is less than 0.02 g/cm<sup>3</sup>. More details can be found in standards ASTM D 2726 for  
20 the water displacement method and ASTM D 1188 for the paraffin-coated method.

Because an asphalt mix is heterogeneous and granular in nature, there is no single density determination method to cover all mix designs. The decision on which density determination method to use depends on the aggregate size and whether it is an open or closed mix design. For example, for mixes using  
25 aggregate with a nominal aggregate size of 9.5 mm and a void content less than about 6%, the water displacement method provides reasonably accurate densities. For open-graded mixes with larger aggregates and coarser gradations, the water displacement method provides densities higher than the "true" densities. For such samples, the industry recommends using paraffin-coated or para-film covered  
30 methods for density determination. However, paraffin-coated and para-film methods are time consuming and their accuracy of density determination have been found to be highly user dependent. Furthermore, for many mix designs, the

dimensional analysis method overestimates the volume and yields lower density values than the other methods. However, literature has shown that dimensional analysis provides better estimates of the densities of highly permeable specimens.

5 With more and more roads being constructed using mixes of large aggregate sizes and/or open graded mix designs, there is a need for developing techniques for determining the density of cylindrical asphalt samples.

For many decades, gamma-ray based nuclear gauges have been successfully used to determine densities of asphalt pavements. This type of gauge provides a non-destructive test method and provides density measurements rapidly  
10 (e.g. within 1 to 4 minutes).

Various designs for gamma-ray based surface gauges, depth probes, and the like have been reported in literature and are available commercially. Single system surface density gauges, such as the Model 3400 series Surface Moisture-Density gauges available from applicant's assignee, Troxler Electronic Laboratories, Inc.,  
15 are designed to be placed on a surface, such as an asphalt pavement surface, and the density determination assumes a sample of relative large or "infinite volume" in relation to the field of view of the gauge. Such gauges are not designed to reliably measure the bulk density of relatively small, "finite volume" samples, such as cylindrically shaped samples of asphalt paving mix.

20 In commonly owned United States Patent 5,151,601, a system is described by which a nuclear asphalt content gauge, such as the Troxler 3200 series asphalt content gauge, can be used to determine the asphalt content of cylindrical samples of asphalt paving mix. However, currently no commercial nuclear gauge is available in the market for determining the density of cylindrical specimens.

## 25 SUMMARY OF THE INVENTION

The present invention provides a nuclear density test instrument and method which is suited for measuring the bulk density of relatively small, "finite volume" samples, and is particularly suited for measuring the bulk density of cylindrical specimens, such as cylindrical core samples or gyratory compacted  
30 specimens of asphalt paving mix.

In one embodiment, the density gauge of the present invention comprises a plurality of sources of gamma radiation positioned in spaced-apart relation from one another for emitting gamma radiation from a plurality of spaced-apart locations into a sample placed nearby and a detector mounted for receiving gamma radiation which has penetrated the sample. Means is provided cooperating with the detector for calculating the bulk density of the sample based upon the gamma radiation counts by the detector. In one embodiment, each of the sources of gamma radiation is preferably a point source, and the sources are preferably mounted to a source plate. The sources are preferably at least three in number and are arranged in a common plane. In a further more specific aspect, the gauge includes a sample holder configured to hold a cylindrically shaped sample, the sample holder being mounted adjacent to said source plate to orient the sources at spaced locations opposite a first end of the cylindrically shaped sample.

Preferably, the detector is an energy selective detector configured to detect gamma radiation in a predetermined energy spectrum, which desirably is within the range of from 0.1 MeV to 2 MeV. The detector may comprise a scintillation detector, and the system may include an analyzer connected to the scintillation detector for detecting gamma radiation in the desired predetermined energy spectrum. In one specific embodiment, each of the sources is a  $^{137}\text{Cs}$  gamma-ray source with a 0.662 MeV primary energy, and the predetermined energy spectrum measured by the gauge falls within the range of 0.25 to 0.73 MeV.

#### BRIEF DESCRIPTION OF THE DRAWINGS

Some of the features and advantages of the invention having been described, others will become apparent from the detailed description which follows, and from the accompanying drawings, in which:

Figure 1 is a schematic elevational view of a gauge in accordance with an embodiment of the invention;

Figure 2 is a top plan view of a source plate for the gauge, shown with five  $10\ \mu\text{Curie}^{137}\text{Cs}$  sources;

Figure 3 is a ray diagram showing the path of the gamma rays from the five source locations through the sample volume to the detector, with the path of unscattered gamma-rays shown in solid lines and the path of scattered gamma-rays shown in dotted lines;

5 Figure 4 is a chart showing a stabilization spectrum;

Figure 5 is a density calibration curve graph;

Figure 6 is a graph comparing the densities determined by the gamma-ray method with densities obtained by the water displacement method; and

10 Figure 7 is a graph showing measured asphalt equivalent normalization factors for metal and rocks.

### DETAILED DESCRIPTION OF THE INVENTION

The present invention now will be described more fully hereinafter with reference to the accompanying drawings, in which preferred embodiments of the invention are shown. This invention may, however, be embodied in many  
15 different forms and should not be construed as limited to the embodiments set forth herein; rather, these embodiments are provided so that this disclosure will be thorough and complete, and will fully convey the scope of the invention to those skilled in the art. Like numbers refer to like elements throughout.

#### **Principle**

20 The present invention is based on the scattering and absorption properties of gamma-rays with matter. For gamma-rays with energies less than 2 MeV, there are two dominant interacting mechanisms with matter. In the 0.1 to 2 MeV energy range, the dominant mechanism is inelastic scattering (Compton scattering). For energies less than 0.1 MeV, the dominant mechanism is photoelectric absorption.  
25 In the 0.1 to 2 MeV energy range, the amount of gamma-ray scattering (energy degradation) is a function of electronic density of the material and hence a fundamental measurement property. This results in a nuclear attenuation per unit length-mass density. As a consequence, one can see that the actual volume of a homogeneous sample is not as critical as it is in the volumetric based system. This  
30 leads to bulk density measurements which are not so affected by the surface properties or texture of a sample. At energies below 0.1 MeV, the photoelectric

absorption of gamma-rays is sensitive to the atomic number of the material and hence to the chemical (elemental) composition of the material. Therefore, when a gamma-ray source of sufficient energy is placed near a material, and an energy selective gamma-ray detector is used for gamma-ray detection, gamma-rays mainly  
5 undergoing Compton scattering can be counted exclusively. With proper calibration, the gamma-ray count can be converted to an absolute density. Also, the unscattered gamma-rays can be counted which is again a function of the material bulk density.

According to one specific embodiment of the invention, a  $^{137}\text{Cs}$  gamma-ray  
10 source with a 0.662 MeV primary energy is used. However, other gamma-ray sources with different primary energy levels could be employed, such as  $^{60}\text{Co}$  for example. Gamma-rays interacting with the sample are detected with a detector, which is preferably an energy selective detector configured to detect gamma radiation in a predetermined energy spectrum. Gamma radiation detectors may be  
15 configured in various ways to be selective to a desired energy spectrum. For example, one may use conventional Geiger-Mueller detector tubes with an appropriate filter, such as cadmium, to filter out low energy gamma radiation. In the embodiment shown and described herein, an energy selective scintillation detector is used, specifically a NaI crystal mounted on a photo-multiplier tube  
20 (PMT). Specifically, when using a  $^{137}\text{Cs}$  source, gamma-rays interacting with or passing through the sample with energies in the range 0.25 to 0.73 MeV are counted. Since these gamma-rays contain Compton scattered gamma-rays and unscattered gamma-rays, the count received by a gamma-ray detector resulting from interactions with the material is a good indicator of the material bulk density.  
25 The technique uses 0.25 MeV as the low energy limit for selecting the gamma-rays. This energy selection avoids counting gamma-rays with energies which depend on the chemical composition of the material. Hence, the chemical composition error is minimized. The upper limit of 0.73 MeV is selected to include substantially all of the gamma-rays with the characteristic 0.662 MeV  
30 primary energy. As seen from Figure 5, the gaussian distribution for the 0.662 MeV peak has its upper base at approximately 0.73 MeV because of the finite resolution of the detector. For gamma-ray sources other than  $^{137}\text{Cs}$ , the upper limit

would be selected in a similar manner based upon the energy distribution for the particular source selected.

According to the present invention, the source-sample-detector configuration is designed to give the best density estimate of a heterogeneous and granular sample. Since point densities of such samples show a distribution of densities, a large sample volume should be used for estimating the bulk density. Since a cylindrical sample of asphalt mix is of relatively small size (or of "finite volume"), it is desired that the probing particles, which are in this case photons (gamma-rays) should traverse the sample to the fullest extent possible, thereby interacting with and sampling a large portion of the limited size sample. To this end, a plurality of spaced apart point-gamma-ray sources are used. In the illustrated embodiment, five separate sources are used and they are arranged on a plate so as to cover a volume generally corresponding to the size of the sample. In the embodiment shown, which is designed to measure a cylindrical shaped asphalt sample, the five sources are arranged such that the gamma-rays traverse directly along several paths through a large portion of the sample volume. To cover the remaining volume not traversed by the direct gamma-rays, the detector counts gamma-rays with energies less than 0.662 MeV. These energy gamma-rays are the result of multiple scattering in the sample, and have thus filled the entire sample volume.

### **Apparatus**

One embodiment of the gauge is shown in Figure 1. This embodiment is designed to operate in the direct transmission mode. The gauge is indicated generally by the reference character 10. The gauge includes a base 12, with a plurality of upright support rods 14 projecting upwardly therefrom. A source plate 16 in the form of a circular disc is supported by the support rods 14. A sample holder 18, configured to receive and hold a test sample 20, is mounted to the support rods 14 just above the source plate 16. In the illustrated embodiment, the test sample is formed of asphalt paving mix compacted in the configuration of a right circular cylinder and the sample holder has a circular flange of a diameter adapted to receive and support one of the flat circular ends of the cylindrical sample. A detector support plate 22, mounted to the support rods 14, suspends a

sodium iodide scintillation detector 24 just above the upper flat circular end of the sample 20. Thus, the sample 20 is located between the gamma-ray source and the gamma-ray detector.

As best seen in Figures 2 and 3, the source plate 16 contains five 10 $\mu$ Curie  
5 <sup>137</sup>Cs sources 26 located in recesses or wells formed in the source plate. The <sup>137</sup>Cs sources may be in the form of pellets of relatively small size in relation to the overall size of the apparatus, and may thus be considered as "point sources". Alternatively, it may be desirable to fabricate the sources so that they occupy a somewhat larger surface area in relation to their thickness, to thereby increase the  
10 interaction of the gamma-rays with the sample. In any event, the location of each source in the source plate is selected such that the direct path of a gamma-ray from the sources to the detector traverses a large portion of the volume of the sample, as may be seen from the ray diagram of Figure 3. The gamma-ray detector is a NaI crystal mounted on a photo-multiplier tube (PMT) 28. The detector system is held  
15 by detector-support-plate 22. The embodiment shown has a sample holder that can accommodate a 150 mm diameter by 110 mm thick cylindrical sample with the cylinder axis in a vertical direction. The apparatus is designed such that the distance between the source plate and the detector support plate can be varied, if necessary. The gauge also has another 1  $\mu$ Curie <sup>241</sup>Am gamma-ray source 30  
20 mounted near the detector for spectrum stabilization.

The NaI/PMT detector system is available commercially from Rexon Components, Inc., of Beachwood, Ohio. A high voltage power supply, preamplifier, amplifier, analog-to-digital converter, digital spectrum stabilizer and multi-channel analyzer (MCA), which are available from manufacturers such as  
25 Canberra Industries, Inc., Meriden, CT, and EG&G ORTEC, Oak Ridge, TN, receive and process the signals from the detector system. The MCA is a computer card that can be installed on a regular personal computer running a Microsoft<sup>TM</sup> operating system.

### Spectrum Stabilization

30 Scintillation detectors are sensitive to temperature fluctuations. In the digital spectrum produced by the MCA (see Figure 4), the x-axis represents the

energy of a gamma-ray and y-axis represents the counts corresponding to a particular gamma-ray energy. When the temperature fluctuates, the spectrum fluctuates in the x-direction. Therefore, a peak once centered on one channel may end up centered on a different channel. If one wants to find the number of gamma-rays with energies between  $E_{\text{lower}}$  and  $E_{\text{upper}}$ , because of these fluctuations, the counts obtained from using the “normal” spectrum will have large uncertainties. This uncertainty is due to the temperature sensitivity. The digital spectrum stabilizer is used to stabilize the spectral drifts resulting from temperature fluctuations in the NaI detector. Two gamma-ray peaks are used for the spectrum stabilization – a 0.056 MeV peak from a 1  $\mu$ Curie  $^{241}\text{Am}$  source placed near the detector and the 0.662 MeV peak from the 50  $\mu$ Curie  $^{137}\text{Cs}$  sources in the source plate.

During a 4 minute counting time, the MCA collects counts in 1-minute increments. Each 1-minute spectrum is then corrected for signal amplitude fluctuations and stored in a buffer. At the end of counting, the MCA gives two spectra – a normal spectrum, which is a spectrum collected without signal amplitude adjustments, and a stabilized spectrum, which is constructed using corrected 1-minute spectra in the buffer. Figure 4 shows an example of a normal spectrum and a stabilized spectrum for a Magnesium cylinder. Note that the centroid of the 0.056 MeV peak in the normal spectrum is in channel number 23 and the same in the stabilized spectrum is in channel number 19. In the normal spectrum, depending on the ambient temperature, the centroid can drift from channel to channel. However, when the digital spectrum stabilizer is used, the centroid will be always brought to channel number 19. This correction is applied across the entire spectrum. During a 48 hour test period, the stabilizer maintained the centroid of the 0.662 MeV  $^{137}\text{Cs}$  peak within  $\pm 0.075$  channel numbers (1-sigma).

### Calibration Method

As with other nuclear gauges, the gauge has to be calibrated to convert gamma-ray counts to material bulk densities. Preliminary calibration was performed using magnesium and aluminum metal cylinders and an asphalt

cylinder. When obtaining counts from spectra, gamma-rays with energies from 0.250 to 0.730 MeV were counted. For a 10-minute count, the precision of density measurement was found to be 0.0015 g/cm<sup>3</sup> at 2.35 g/cm<sup>3</sup> (1-sigma). For a 4-minute count, at the same density, the precision lowered to about 0.0045 g/cm<sup>3</sup> (1-sigma). Note that 1 lb/ft<sup>3</sup> (PCF) = 0.01602 g/cm<sup>3</sup>. The density determined by the method was found to be independent of the sample orientation. Such orientations are 1) a rotation about a vertical axis through the center of the sample holder, and 2) placing the sample on the sample holder with face up or down.

The gauge was used to determine the densities of several samples. Samples were placed on the holder in a random orientation with the cylinder axis near the vertical line passing through the center of the sample holder. For each sample, several measurements were made on different days. Using the same calibration, the density was determined for 10-minute counts (Table 1). The measurement repeatability for 10-minute counts was about 0.002 g/cm<sup>3</sup> (1-sigma).

Twelve asphalt cylinders (Table 2, sample numbers 1 to 12) were used to calibrate the prototype gauge. All samples were 150 mm diameter by 115 mm high cylindrical samples with North Carolina granite as the aggregate type with nominal sizes 9.5 mm and 12.5 mm. Densities of all samples were determined by the water displacement method ( $G_{mb}$ ). Heights of the samples were measured using a vernier caliper. The background radiation from the sample and its surrounding was measured by taking counts when the five point <sup>137</sup>Cs gamma-ray sources were not present in the source holder. An average value of the background in the energy interval from 0.25 to 0.73 MeV was used to determine the true gamma-ray count at the detector from the five point <sup>137</sup>Cs sources. Some properties of the samples are given in Table 2. The count ratio (CR) for each sample was determined by

$$CR = \frac{(Cnt - Bgd)}{Std}$$

Where

- $Cnt$  = 10-minute gamma-ray count,  
 $Bgd$  = 10-minute average background count, and  
 $Std$  = 10-minute gamma-ray count for Magnesium cylinder minus  $Bgd$ .

Figure 5 shows the count ratio ( $CR$ ) vs. area density ( $D'$ ) for all samples.

Here,

$$D' = G_{mb}h$$

Here,  $h$  is the height of the cylinder. The curve in Figure 5 is the best fit to  
5 data of the form

$$CR = Ae^{-BD'} - C$$

Where  $A$ ,  $B$ , and  $C$  are the fitting coefficients or calibration constants. The best fit gave the following values for the three calibration constants.

$$A = 2.6750$$

$$10 \quad B = 0.04790 \text{ cm}^2/\text{g}, \text{ and}$$

$$C = 6.36 \text{ E-}10.$$

The coefficient of determination,  $R^2$ , for the fit is 0.996.

Using the density calibration, bulk densities of twenty-one unknown asphalt cylinders were measured (Table 2, sample numbers 13 to 33). The densities  
15 were calculated using the calibration constants  $A$ ,  $B$ , and  $C$ , the standard count  $Std$ , the average background count  $Bgd$ , the height of the cylinder  $h$ , and the count ratio  $CR$ . The density  $D$  is given by

$$D = \frac{-1}{Bh} \text{Ln}\left(\frac{CR + C}{A}\right)$$

Then, the densities of all samples were determined by the water displacement  
20 method ( $G_{mb}$ ).

Figure 6 shows a comparison between the densities of unknown asphalt samples determined by the water displacement method and by the gamma-ray method. The line in this figure is the regression line with an  $R^2$  of 0.988. The density differences for all samples (listed in the column labeled  $G_{mb} - D$ ) are  
25 shown in Table 3. The density difference for asphalt samples were  $-0.006 \pm 0.011$   $\text{g}/\text{cm}^3$  (1-sigma) with a minimum difference of  $-0.015 \text{ g}/\text{cm}^3$  and a maximum difference of  $0.033 \text{ g}/\text{cm}^3$ .

All asphalt cylinders, cylinders used for calibration and cylinders used as unknowns, were then used to determine the calibration coefficients for asphalt  
30 mixes made with granite-type aggregates (Figure 7). Based on this best curve,

calculations were made of the normalization factors for converting gravimetric densities to "asphalt equivalent" densities for metal and rock samples. These factors are given in Table 4 together with the normalization factors that Troxler™ nuclear surface gauges routinely use.

- 5 When calibrating the gauge, one can then use three metal or rock cylinders with 'asphalt equivalent' densities instead of a large number of cylinders made with real asphalt mixes.

**Table 1: Repeatability of sample counts and densities**

Sample	01/03/00	01/05/00	01/11/00	01/13/00
Mg (1762 kg/m <sup>3</sup> )	1761	1765	1763	1767
	1762		1762	1768
				1763
				1768
Al (2574 kg/m <sup>3</sup> )	2573	2575	2575	2578
	2576		2574	2578
RT-03-01 (2141 kg/m <sup>3</sup> )	2141	2139	2141	2143
			2143	2145
BAZ-01-01 (2487 kg/m <sup>3</sup> )	2463	2463	NA	NA
CAY-09-01 (2451 kg/m <sup>3</sup> )	NA	NA	2458	2463
			2461	2458

10

NA -- Not Available

Table 2

Sample Number	Sample I.D.	Diameter (in)	Height (in)	M/V (g/cc)	Gmb (g/cc)	Size	AC (%)	Gmm (g/cc)
1	RT-01-01	5.911	4.575	2.342	2.357	RI-2 9.5 mm	6.3	2.409
2	RT-01-02	5.911	4.573	2.343	2.359	RI-2 9.5 mm	6.3	2.409
3	RT-02-01	5.913	4.549	2.234	2.259	RI-2 9.5 mm	6.3	2.409
4	RT-02-02	5.906	4.550	2.238	2.261	RI-2 9.5 mm	6.3	2.409
5	RT-03-01	5.914	4.551	2.113	2.141	RI-2 9.5 mm	6.3	2.409
6	RT-03-02	5.916	4.544	2.115	2.143	RI-2 9.5 mm	6.3	2.409
7	BAZ-01-01	5.908	4.496	2.454	2.487	SP 9.5 mm	5.4	2.531
8	BAZ-02-01	5.906	4.497	2.357	2.401	SP 9.5 mm	5.4	2.531
9	BAZ-03-02	5.907	4.528	2.240	2.303	SP 9.5 mm	5.4	2.531
10	BAZ-04-01	5.930	4.486	2.146	2.218	SP 9.5 mm	5.4	2.531
11	H-1	5.910	4.534	2.476	2.527	SP 12.5 mm	5.2	2.593
12	H-2	5.912	4.537	2.471	2.525	SP 12.5 mm	5.2	2.593
13	CAY-08-04	5.914	4.584	2.352	2.448	CCM 9.5 mm	5.4	2.531
14	CAY-08-05	5.912	4.582	2.354	2.451	CCM 9.5 mm	5.4	2.531
15	CAY-08-06	5.901	4.501	2.408	2.445	CCM 9.5 mm	5.4	2.531
16	CAY-09-01	5.913	4.546	2.445	2.504	CCM 19.0 mm	4.5	2.597
17	CAY-09-02	N/A	4.558	N/A	2.502	CCM 19.0 mm	4.5	2.597
18	CAY-09-03	N/A	4.576	N/A	2.498	CCM 19.0 mm	4.5	2.597
19	759-05	N/A	4.599	N/A	2.302	RI-2 9.5 mm	6.3	2.409
20	759-07	N/A	4.606	N/A	2.292	RI-2 9.5 mm	6.3	2.409
21	759-08	N/A	4.583	N/A	2.303	RI-2 9.5 mm	6.3	2.409
22	771-01	N/A	4.512	N/A	2.441	CCM 9.5 mm	5.4	2.531
23	771-03	N/A	4.490	N/A	2.445	CCM 9.5 mm	5.4	2.531
24	771-04	N/A	4.514	N/A	2.438	CCM 9.5 mm	5.4	2.531
25	772-01	N/A	4.508	N/A	2.437	CCM 9.5 mm	5.4	2.531
26	772-02	N/A	4.489	N/A	2.444	CCM 9.5 mm	5.4	2.531
27	772-03	N/A	4.503	N/A	2.438	CCM 9.5 mm	5.4	2.531
28	223-02	N/A	4.598	N/A	2.396	CCM 9.5 mm	5.4	2.531
29	223-03	N/A	4.617	N/A	2.384	CCM 9.5 mm	5.4	2.531
30	223-04	N/A	4.558	N/A	2.409	CCM 9.5 mm	5.4	2.531
31	746-01	N/A	4.582	N/A	2.309	RI-2 9.5 mm	6.3	2.409
32	746-02	6.011	4.576	1.762	2.309	RI-2 9.5 mm	6.3	2.409
33	746-03	N/A	4.570	N/A	2.310	RI-2 9.5 mm	6.3	2.409

NA -- Not Available

Table 3: Comparison of Densities Determined by the Invention to that by the Water Displacement Method

Sample Number	Sample I.D.	$G_{mb}$ (g/cc)	Height (in)	Count (10 min)	$Bgd$ (10 min)	Net Count (10 min)	Ratio	$D$ (g/cc)	$G_{mb}-D$ (kg/m <sup>3</sup> )
1	RT-01-01	2.355	4.575	1743280	64000	1679280	0.720	2.358	-2.6
2	RT-01-02	2.35	4.573	1743317	64000	1679317	0.720	2.359	-8.6
3	RT-02-01	2.26	4.549	1843631	64000	1779631	0.763	2.266	-6.2
4	RT-02-02	2.257	4.55	1840810	64000	1776810	0.762	2.269	-11.5
5	RT-03-01	2.141	4.551	1973188	64000	1909188	0.819	2.138	2.7
6	RT-03-02	2.147	4.544	1963662	64000	1899662	0.815	2.151	-3.6
7	BAZ-01-01	2.487	4.496	1669048	64000	1605048	0.688	2.482	5.4
8	BAZ-02-02	2.401	4.497	1738441	64000	1674441	0.718	2.404	-2.7
9	BAZ-03-02	2.303	4.528	1836585	64000	1772585	0.760	2.284	19.1
10	BAZ-04-01	2.218	4.486	1930013	64000	1866013	0.800	2.211	6.8
11	H-1	2.527	4.534	1610913	64000	1546913	0.663	2.528	-0.7
12	H-2	2.525	4.537	1613565	64000	1549565	0.664	2.523	2.1
13	CAY-08-04	2.448	4.478	1720589	64000	1656589	0.710	2.434	14.4
14	CAY-08-05	2.451	4.474	1720816	64000	1656816	0.710	2.436	15.5
15	CAY-08-06	2.445	4.501	1700748	64000	1636748	0.702	2.443	1.8
16	CAY-09-01	2.504	4.546	1645141	64000	1581141	0.678	2.481	22.5
17	CAY-09-02	2.502	4.558	1650293	64000	1586293	0.680	2.469	32.9
18	CAY-09-03	2.498	4.576	1628947	64000	1564947	0.671	2.484	14.3
19	759-05	2.302	4.599	1784293	64000	1720293	0.738	2.302	-0.1
20	759-07	2.292	4.606	1788908	64000	1724908	0.740	2.294	-1.9
21	759-08	2.303	4.583	1787279	64000	1723279	0.739	2.307	-4.1
22	771-01	2.441	4.512	1699848	64000	1635848	0.701	2.438	2.8
23	771-03	2.445	4.49	1710575	64000	1646575	0.706	2.438	6.8
24	771-04	2.438	4.514	1700193	64000	1636193	0.702	2.437	1.2
25	772-01	2.437	4.508	1709851	64000	1645851	0.706	2.429	7.7
26	772-02	2.444	4.489	1709257	64000	1645257	0.705	2.440	3.8
27	772-03	2.438	4.503	1709436	64000	1645436	0.706	2.432	5.6
28	223-02	2.396	4.598	1710967	64000	1646967	0.706	2.381	15.5
29	223-03	2.384	4.617	1694632	64000	1630632	0.699	2.388	-4.5
30	223-04	2.409	4.558	1716174	64000	1652174	0.708	2.396	13.3
31	746-01	2.309	4.582	1782925	64000	1718925	0.737	2.312	-3.1
32	746-02	2.309	4.576	1781946	64000	1717946	0.737	2.316	-7.2
33	746-03	2.31	4.57	1776317	64000	1712317	0.734	2.325	-15.1
34	Mg	1.784	4.531	2393211	61148	2332063	1	1.762	21.6
35	Lime	2.2	4.541	1877033	59481	1817552	0.779	2.229	-29.5
36	Granite	2.625	4.56	1536033	81564	1454469	0.624	2.639	-14.5
37	Al	2.713	4.528	1536514	58580	1477934	0.634	2.628	85.2

$Bgd$  -- Background

**Table 4 Asphalt equivalent density normalization factors**

Sample	Normalization Factor		
	"Asphalt Cylinder"	"Soil" (for M34XX)	"asphalt" (for M3450 & M4640)
Magnesium	0.9931	0.988	0.988
Limestone	1.0142	1.01	--
Granite	1.0022	0.99	--
Aluminum	0.9650	0.964	0.949

Many modifications and other embodiments of the invention will come to mind to one skilled in the art to which this invention pertains having the benefit of the teachings presented in the foregoing descriptions and the associated drawings.

5 Therefore, it is to be understood that the invention is not to be limited to the specific embodiments disclosed and that modifications and other embodiments are intended to be included within the scope of the appended claims. Although specific terms are employed herein, they are used in a generic and descriptive sense only and not for purposes of limitation.

THE EMBODIMENTS OF THE INVENTION IN WHICH AN EXCLUSIVE PROPERTY OR PRIVILEGE IS CLAIMED ARE DEFINED AS FOLLOWS:

1. Apparatus for measuring bulk density of a cylindrically shaped sample, comprising:
  - a base;
  - a sample holder carried by said base and having a surface configured for receiving and holding a first surface of the cylindrically shaped sample;
  - a cylindrical sample having flat circular end surfaces, one of the flat end surfaces being positioned on the sample holder;
  - a plate mounted in proximity to said sample holder;
  - at least three sources of gamma radiation located in said plate adjacent said sample holder, said sources being positioned in spaced-apart relation from one another for emitting gamma radiation from at least three spaced-apart locations into said sample, each of said sources comprising an isotope having a characteristic primary energy;
  - a detector located on the opposite side of the cylindrically shaped sample from said first surface, the detector being positioned and arranged so as to receive gamma radiation that traversed through the sample along respective independent paths of travel from each of said sources of gamma radiation, said detector being configured to detect gamma radiation in a predetermined energy spectrum; and
  - means cooperating with said detector for calculating the bulk density of the sample based upon gamma radiation counts detected by said detector.
2. Apparatus according to claim 1, wherein said detector comprises a scintillation detector, and wherein said means for calculating the bulk density of the sample includes an analyzer connected to said scintillation detector for detecting gamma radiation in a predetermined energy spectrum.
3. Apparatus according to claim 2, wherein said predetermined energy spectrum falls within the range of 0.1 MeV to 2 MeV.
4. Apparatus according to claim 3, wherein each of said sources comprises a  $^{137}\text{Cs}$  gamma-ray source with a 0.662 MeV primary energy.
5. Apparatus according to claim 4, wherein said predetermined energy spectrum falls within the range of 0.25 to 0.73 MeV.
6. Apparatus according to claim 2, wherein each of said sources has a radiation activity of no more than 20 microcurie.

7. Apparatus according to claim 2, wherein the total radiation activity of all of said sources does not exceed 10 microcurie.

8. Apparatus according to claim 2, additionally including a digital spectrum stabilizer operable to compensate for spectral drifts in said scintillation detector.

9. Apparatus according to claim 8, wherein said digital spectrum stabilizer includes a reference source of gamma radiation having a characteristic primary energy different from that of said sources and outside of said predetermined energy spectrum.

10. Apparatus according to claim 1, wherein said sample holder is of a planar, generally circular configuration for receiving a generally planar first end of the cylindrically shaped sample, and wherein said detector is mounted adjacent to a generally planar second end of the cylindrically shaped sample.

11. Apparatus according to claim 10, wherein said plate is in the form of a circular disc, and said sources of gamma radiation are located in the disk at locations selected such that the direct path of a gamma-ray from the respective sources to the detector traverses a large portion of the volume of the sample.

12. A method for measuring bulk density of a cylindrically shaped sample, comprising:

providing a cylindrically shaped sample,

positioning a first surface of the sample in proximity to at least three sources of gamma radiation, said sources being positioned in spaced-apart relation from one another, and directing gamma radiation from said at least three spaced-apart gamma radiation sources into said sample, each of said sources comprising an isotope having a characteristic primary energy;

positioning a detector on the opposite side of the cylindrically shaped sample from said first surface, the detector being positioned and arranged so as to receive gamma radiation that traversed through the sample along respective independent paths of travel from each of said sources of gamma radiation; and detecting gamma radiation in a predetermined energy spectrum; and

calculating the bulk density of the sample based upon the gamma radiation counts by said detector.

13. A method according to claim 12, wherein said step of calculating bulk density comprises calculating the bulk density of the sample based upon the gamma radiation counts in a predetermined energy spectrum falling within the range of from 0.1 MeV to a maximum value corresponding to the base of the characteristic primary energy of said sources.

14. A method according to claim 13, wherein said step of calculating the bulk density of the sample comprises detecting gamma radiation in a predetermined energy spectrum within the range of 0.1 MeV to 2 MeV.

15. A method according to claim 14, wherein each of said sources comprises a  $^{137}\text{Cs}$  gamma-ray source with a 0.662 MeV primary energy.

16. A method according to claim 15, wherein said predetermined energy spectrum falls within the range of 0.25 to 0.73 MeV.

17. A method according to claim 12, wherein each of said sources has a radiation activity of no more than 20 microcurie.

18. A method according to claim 12, wherein the total radiation activity of all of said sources does not exceed 10 microcurie.

19. A method according to claim 12, wherein said cylindrically shaped sample has flat, generally circular opposite ends, and said step of directing radiation comprises directing gamma radiation into a first circular end of the cylindrically shaped sample, and said detecting step comprises detecting radiation at the opposite circular end of said cylindrically shaped sample.

20. A method according to claim 12, wherein the detector is a scintillation detector, and including the steps of detecting gamma radiation from a reference source of gamma radiation having a characteristic primary energy different from that of said sources and outside of said predetermined energy spectrum, and compensating

for spectral drifts in said scintillation detector based upon the detected radiation from said reference source.

1/7

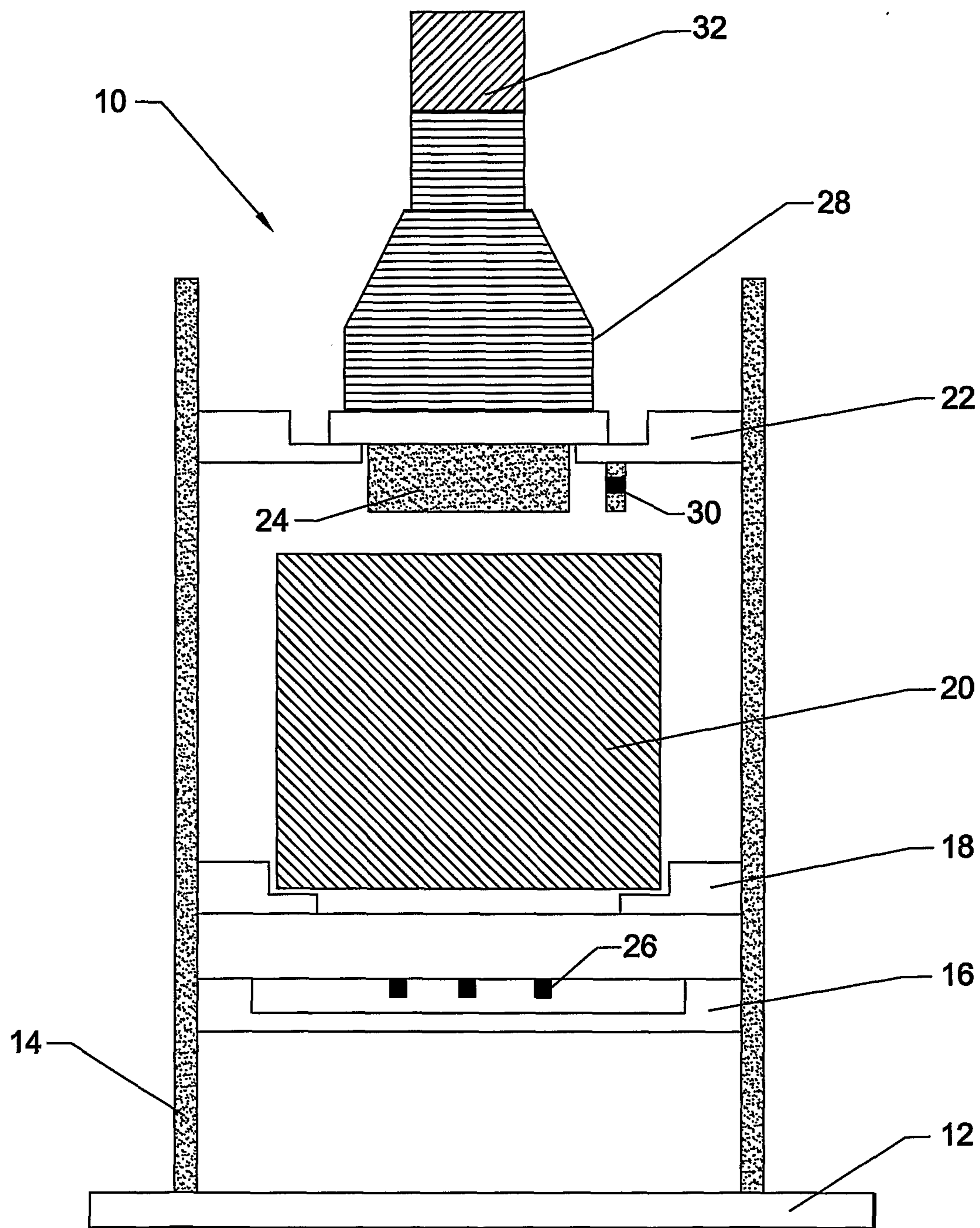

**FIG. 1.**

2/7

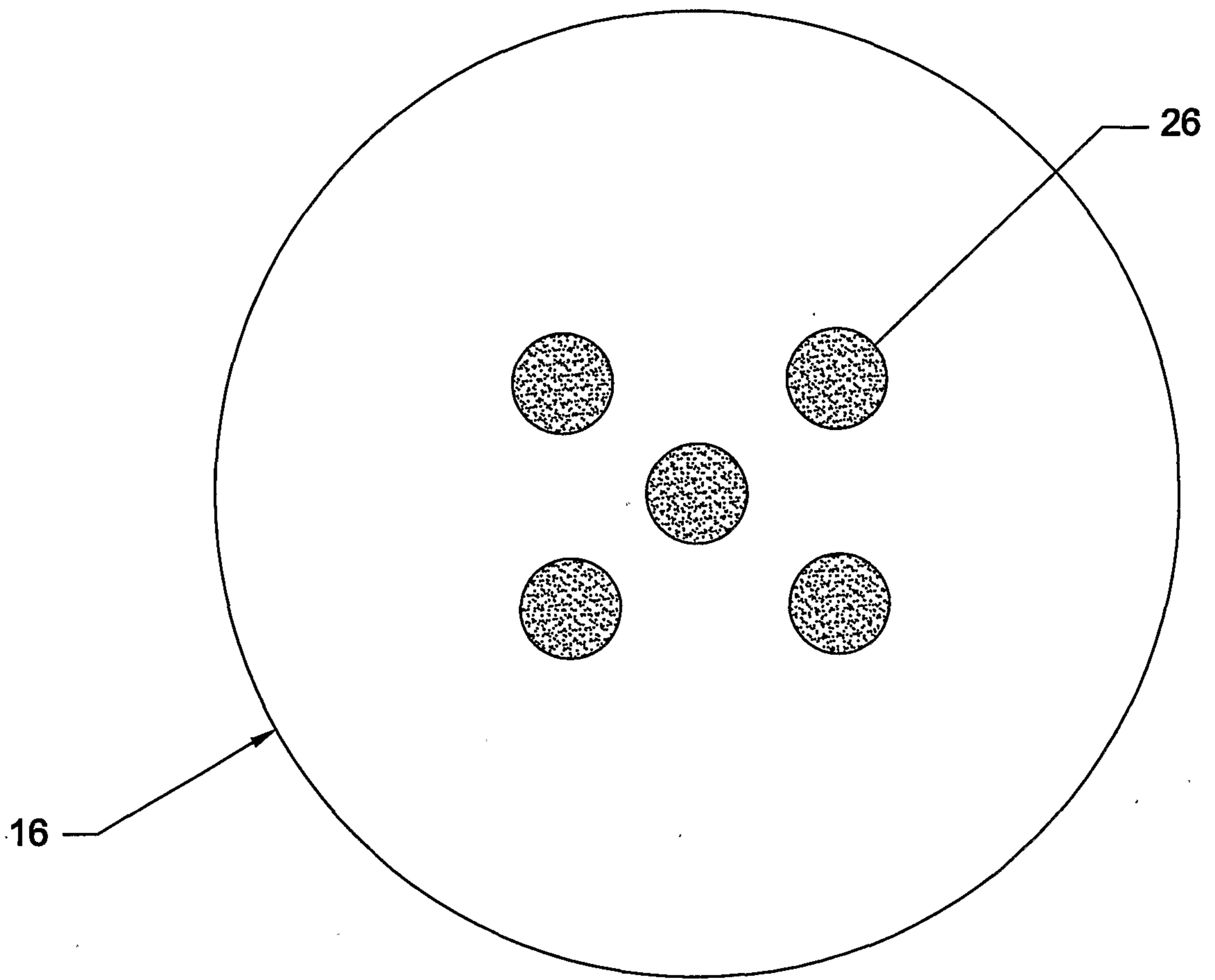
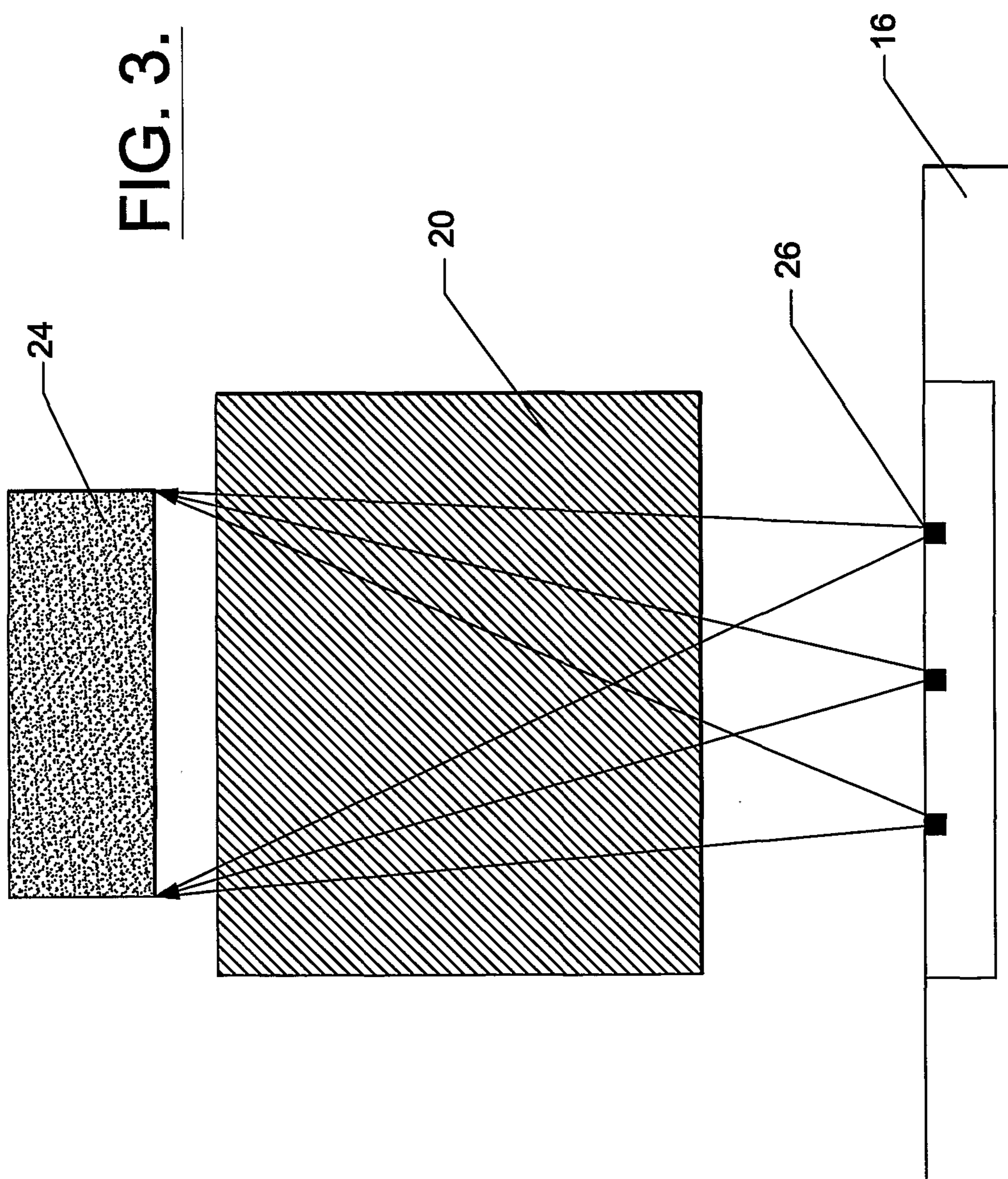
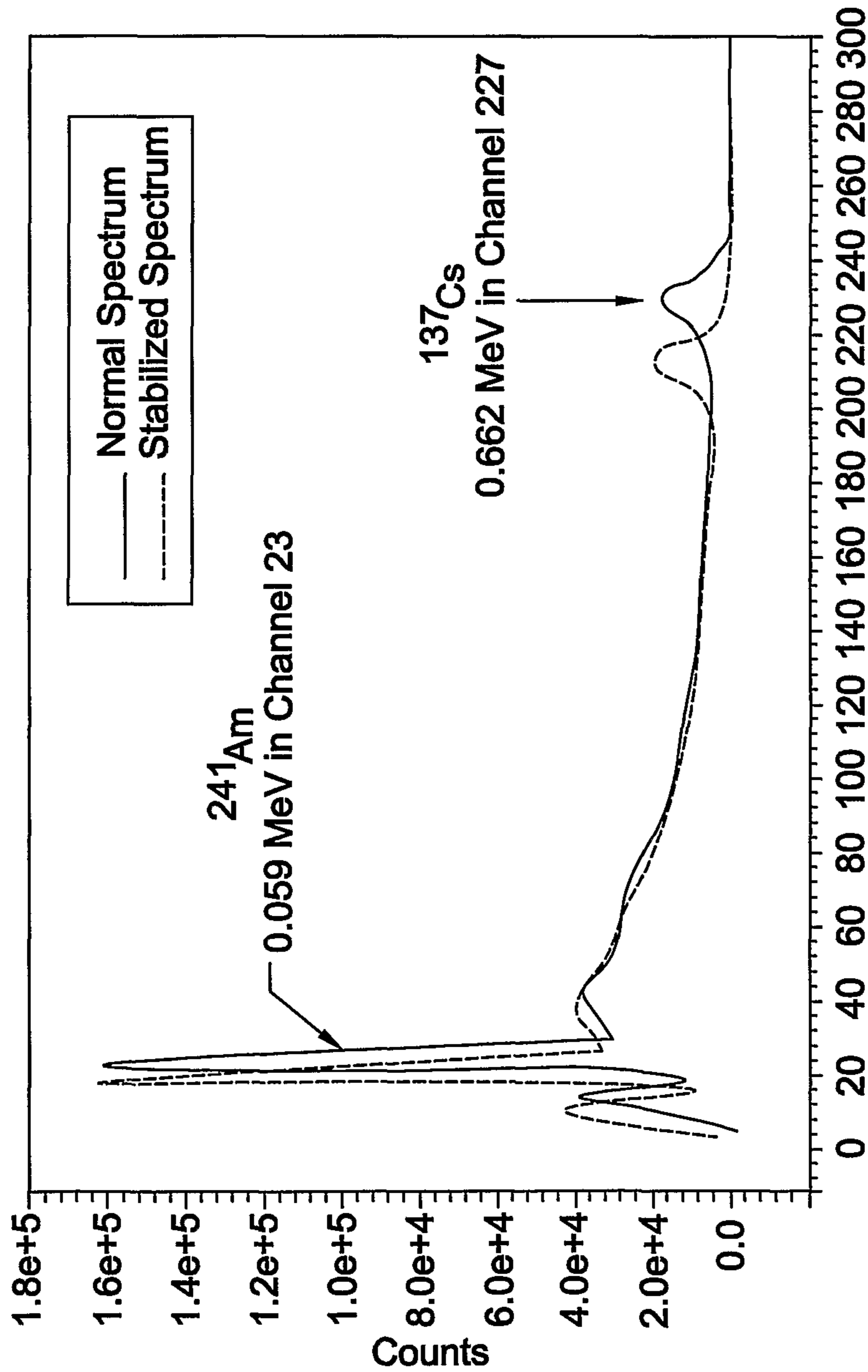

FIG. 2.

**FIG. 3.**





**FIG. 4.**

Normal and Stabilized Spectra of an Asphalt Sample

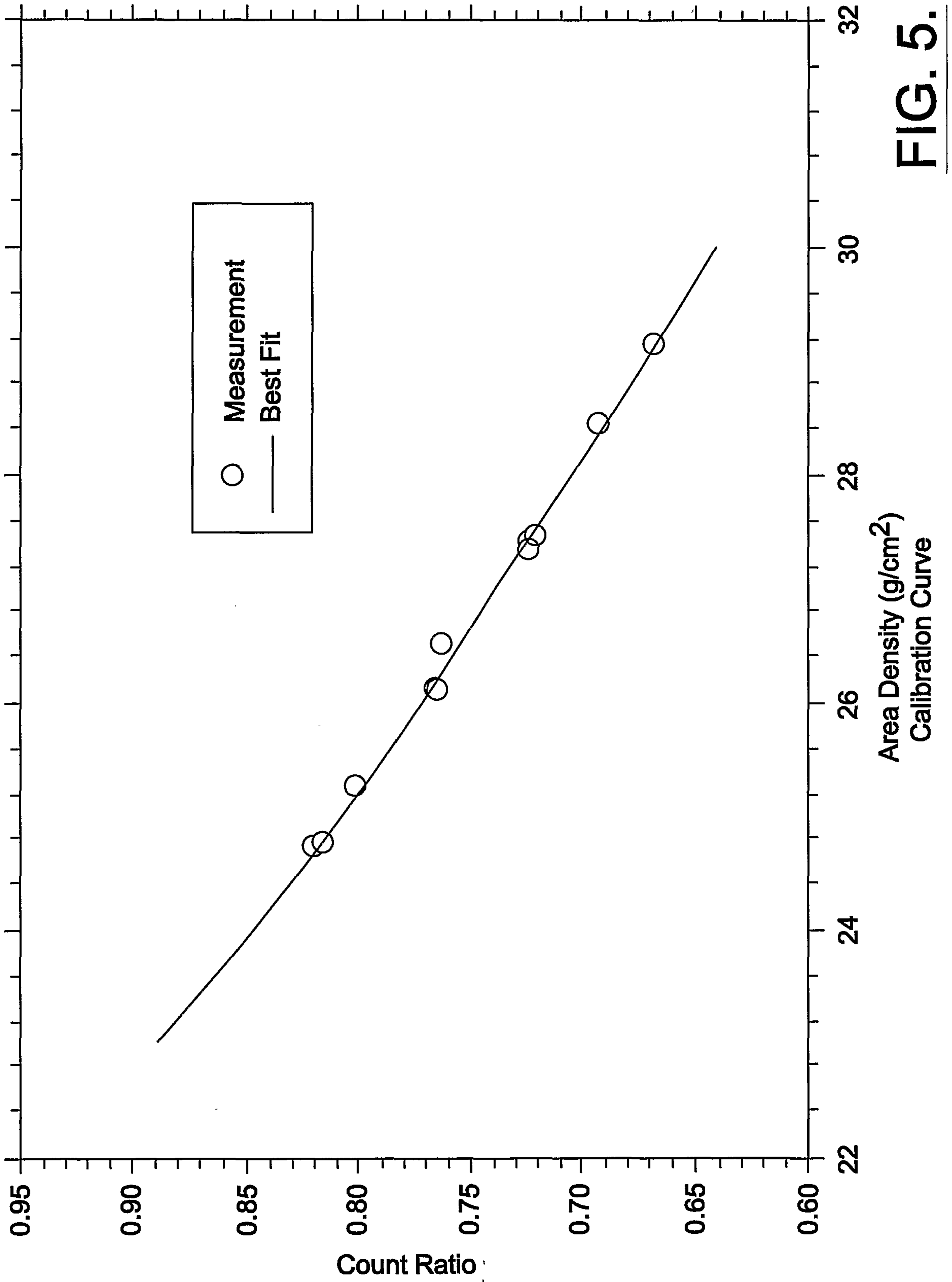
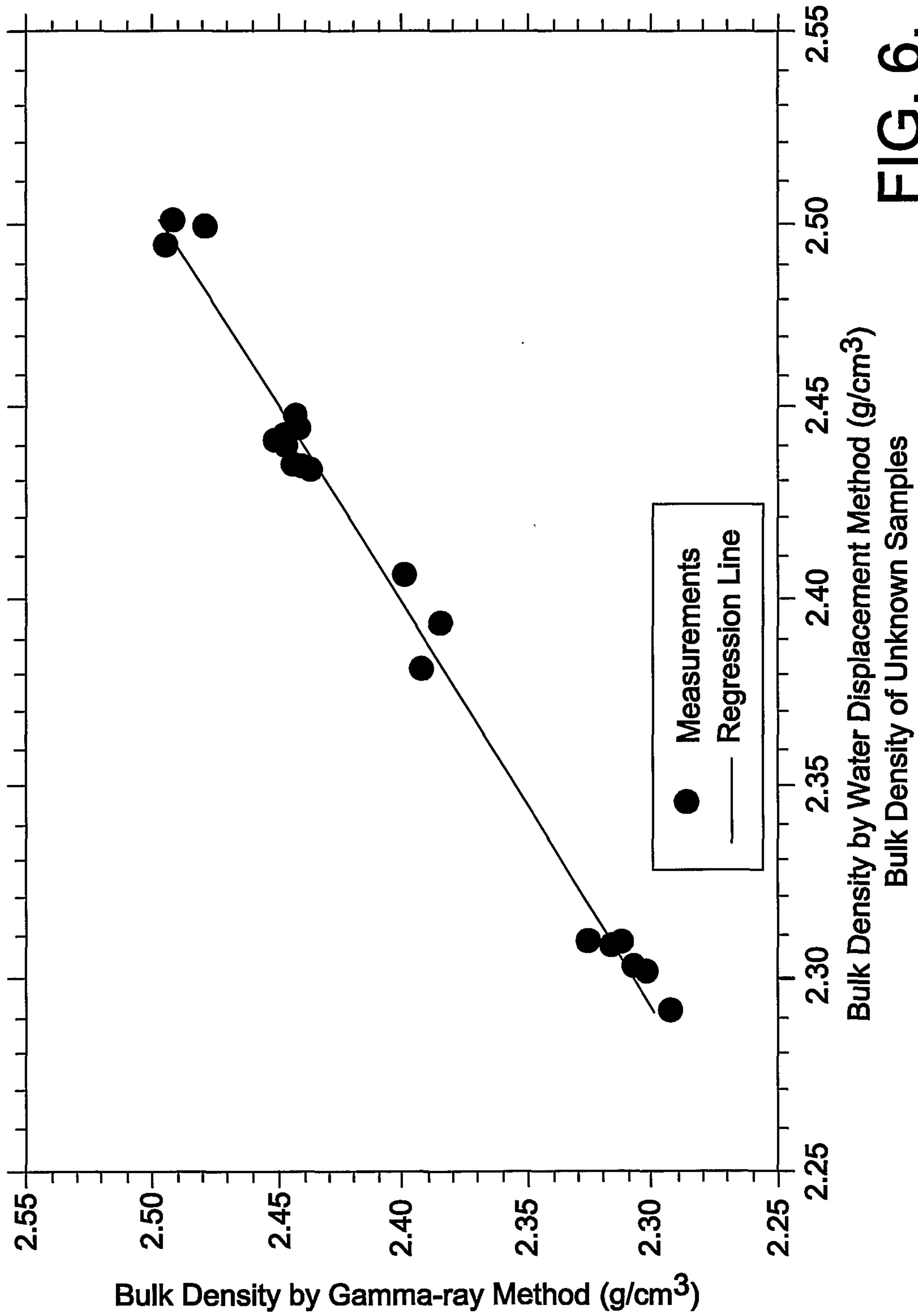
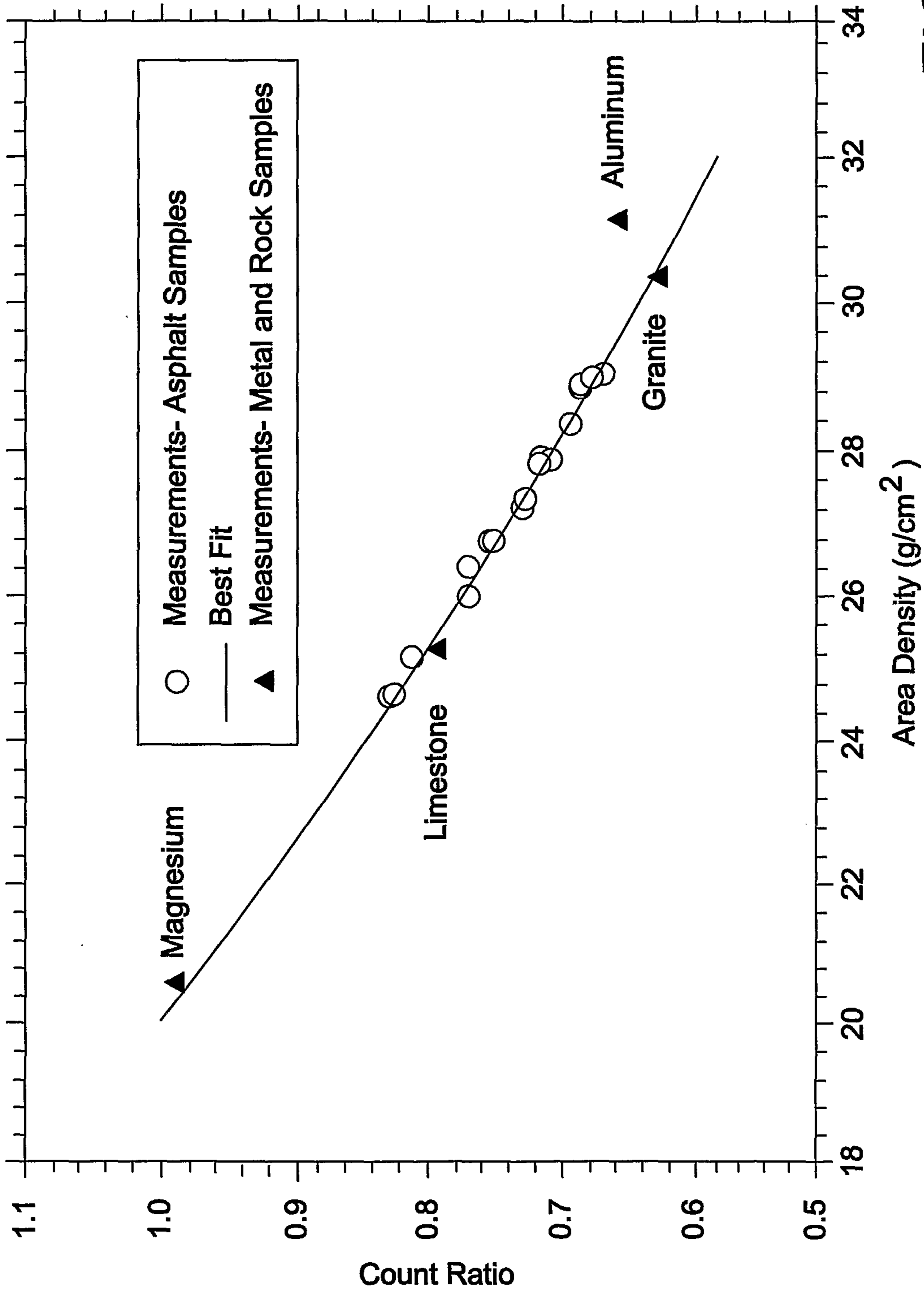

FIG. 5.

Area Density (g/cm<sup>2</sup>)  
Calibration Curve



**FIG. 6.**



Asphalt Equivalent Normalization Factors for Metal and Rock Samples **FIG. 7.**

