



US00D527751S

(12) **United States Design Patent**
Kondoh et al.

(10) **Patent No.:** **US D527,751 S**

(45) **Date of Patent:** **** Sep. 5, 2006**

(54) **TRANSFER-CHAMBER**

(75) Inventors: **Keisuke Kondoh**, Yamanashi (JP);
Hiroki Oka, Yamanashi (JP); **Hiroshi Narushima**, Yamanashi (JP)

(73) Assignee: **Tokyo Electron Limited**, Tokyo (JP)

(**) Term: **14 Years**

(21) Appl. No.: **29/217,729**

(22) Filed: **Nov. 22, 2004**

(30) **Foreign Application Priority Data**

May 28, 2004 (JP) 2004-015725

(51) **LOC (8) Cl.** **15-09**

(52) **U.S. Cl.** **D15/144.1**

(58) **Field of Classification Search** D15/144,
D15/144.1, 144.2; 29/25.01; 62/55.5; 118/620,
118/719, 733; 165/1; 361/65; 392/416; 414/217,
414/416, 716, 786, 935-941; 204/298.11;
427/225, 248.1, 250

See application file for complete search history.

(56) **References Cited**

U.S. PATENT DOCUMENTS

D436,609 S * 1/2001 Tepman D15/144.1
D446,506 S * 8/2001 Tepman D13/182
6,440,261 B1 * 8/2002 Tepman et al. 414/937
2002/0134506 A1 * 9/2002 Franklin et al. 118/719

* cited by examiner

Primary Examiner—Antoine D. Davis
Assistant Examiner—Patricia Palasik
(74) *Attorney, Agent, or Firm*—Smith, Gambrell & Russell, LLP

(57) **CLAIM**

The ornamental design for a transfer-chamber, as shown and described.

DESCRIPTION

The present article relates to a transfer-chamber of a multi-chamber type semiconductor substrate processing apparatus for a film forming process and other processes for semiconductor substrates and others to be processed. A plurality of process chambers are provided around the transfer-chamber so as to transfer the substrate received from a load-lock chamber to, through a loader-module shown in a reference drawing illustrating a state of usage of the transfer-chamber, the process chambers by means of a vacuum arm provided in the transfer-chamber.

FIG. 1 is a front elevational view of the transfer-chamber;

FIG. 2 is a back elevational view thereof;

FIG. 3 is a top view thereof;

FIG. 4 is a bottom view thereof;

FIG. 5 is a right side view thereof;

FIG. 6 is a left side view thereof;

FIG. 7 is 7—7 sectional view shown in FIG. 3.

FIG. 8 is 8—8 sectional view shown in FIG. 3.

FIG. 9 is 9—9 sectional view shown in FIG. 5.

FIG. 10 is a perspective view thereof; and,

FIG. 11 is a reference figure showing a bottom perspective view thereof.

1 Claim, 8 Drawing Sheets

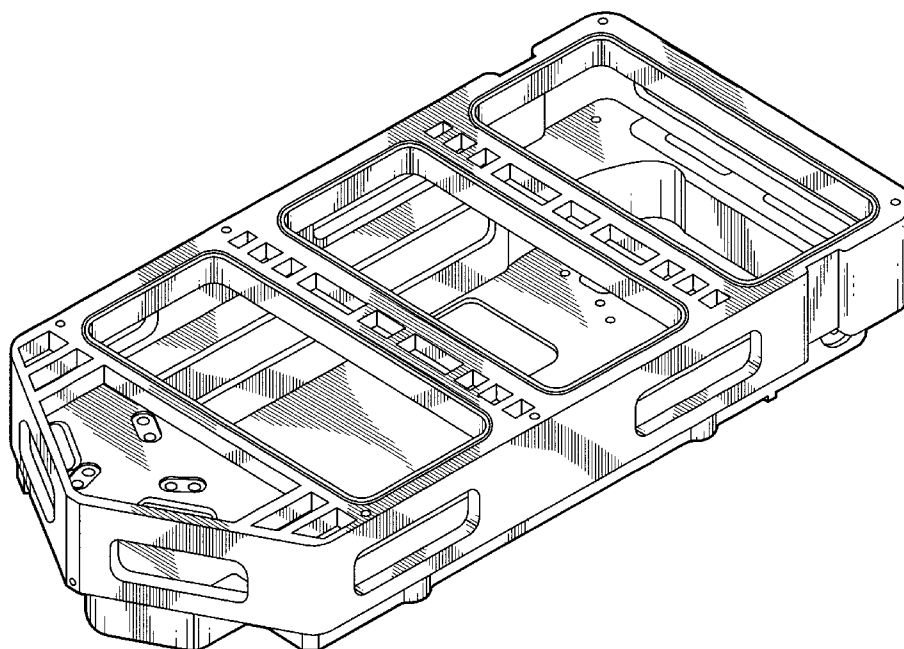

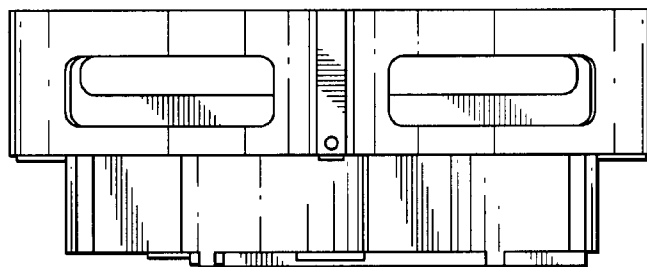

FIG. 1

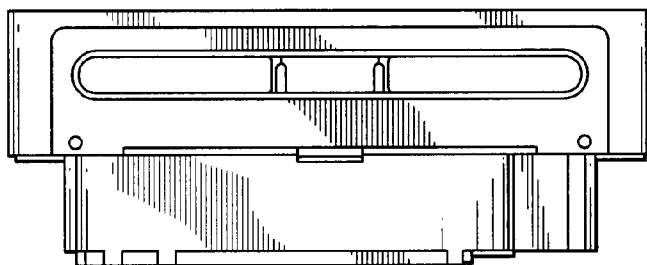

FIG. 2

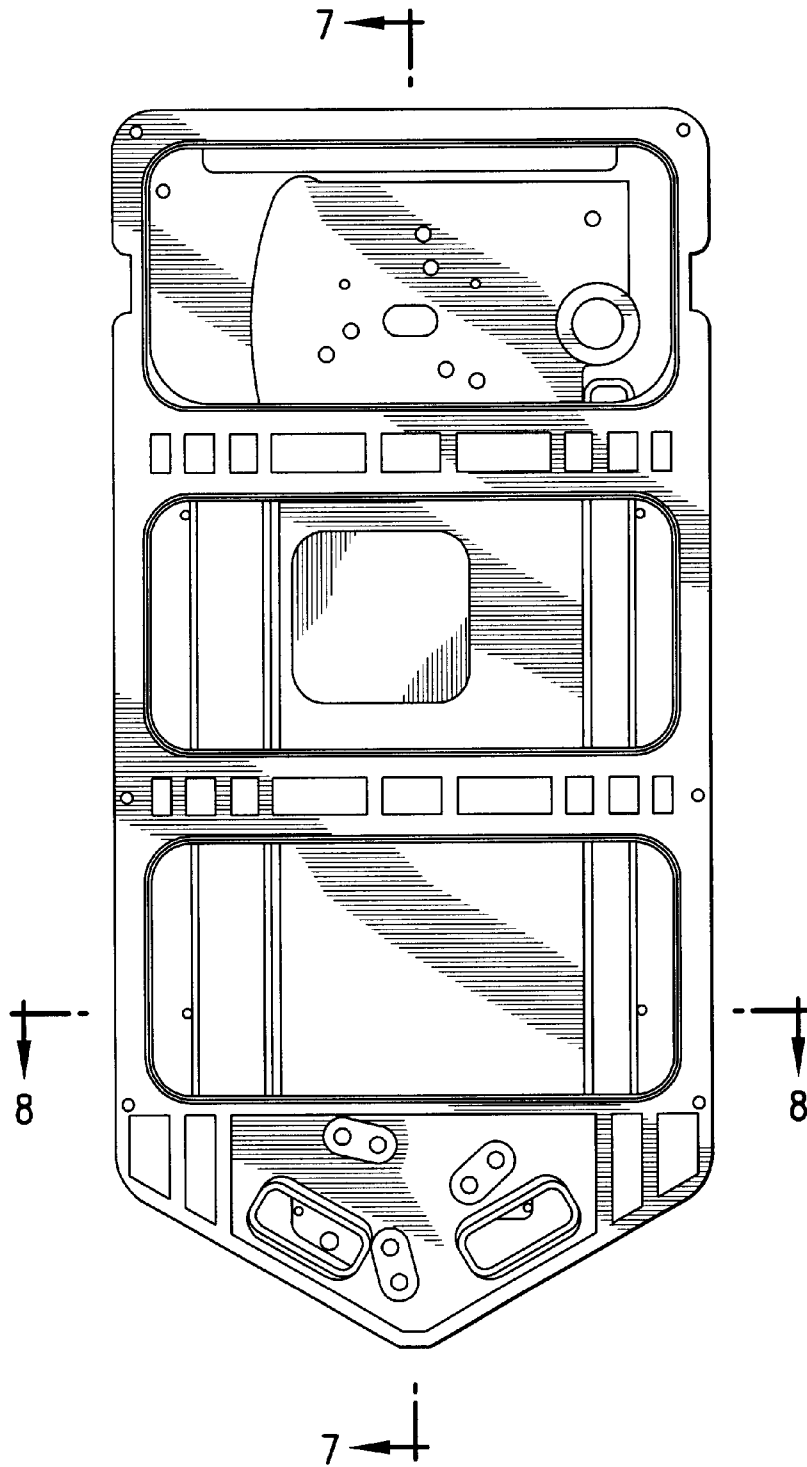

FIG. 3

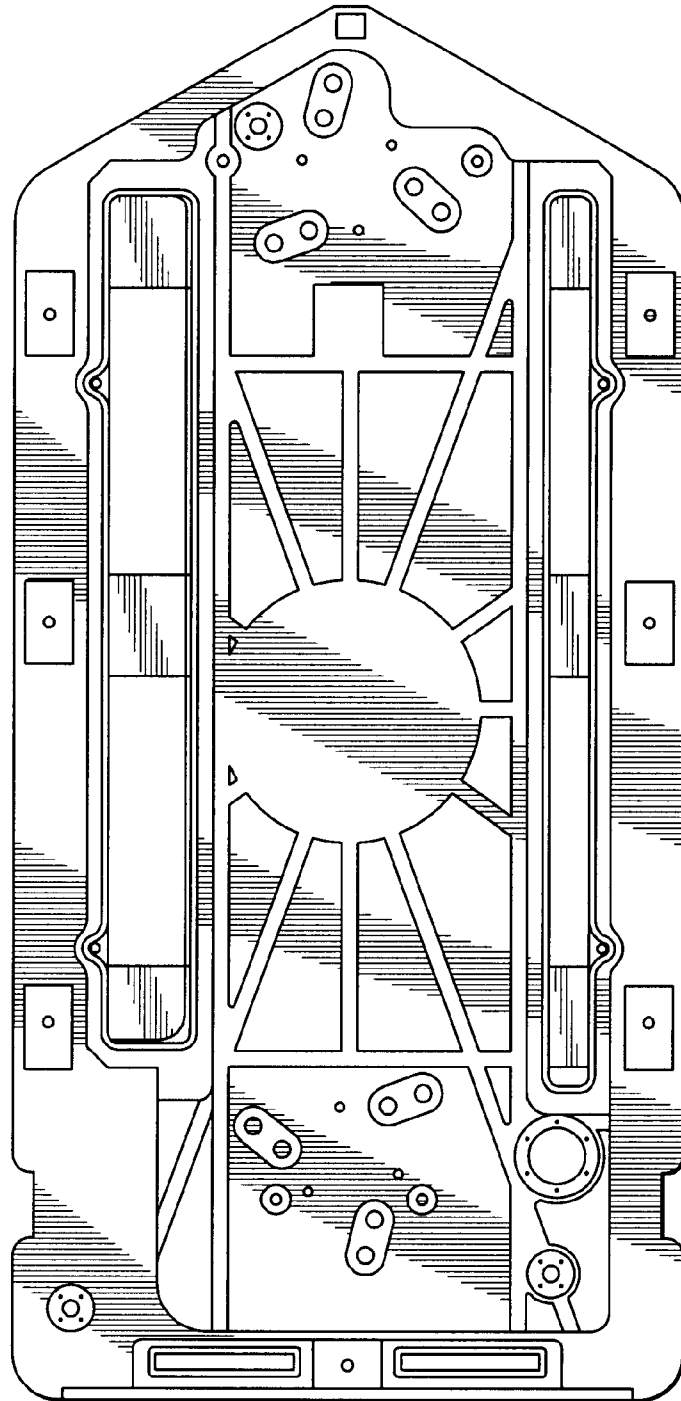

FIG.4

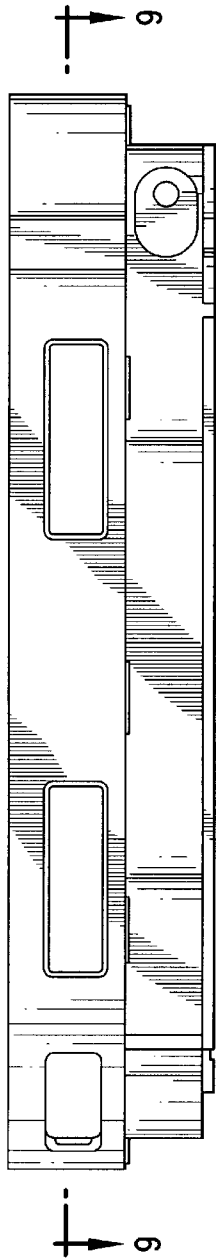

FIG. 5

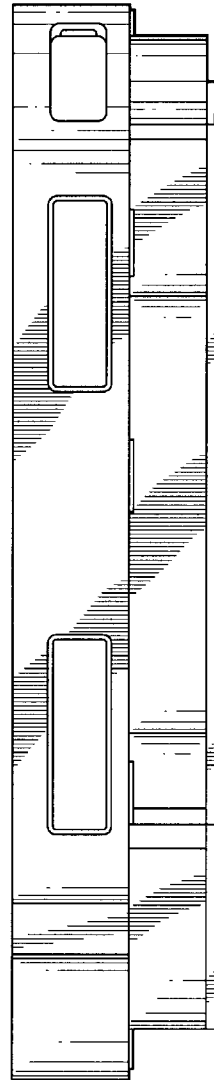

FIG. 6

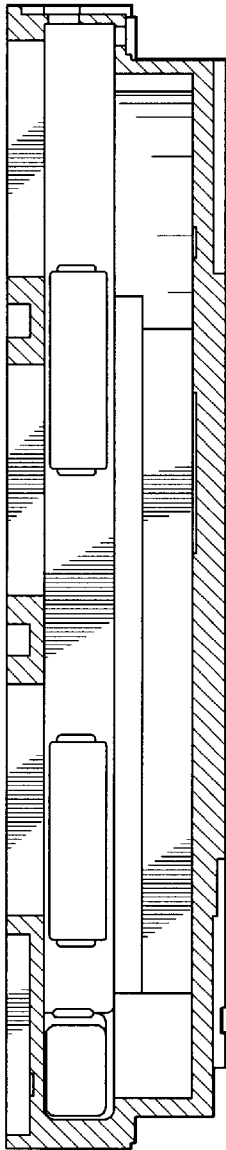

FIG. 7

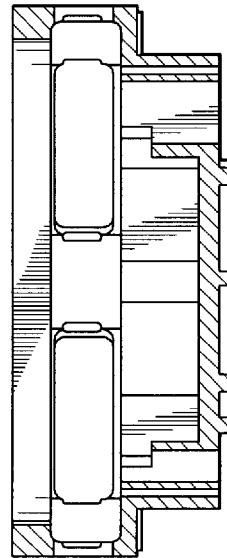

FIG. 8

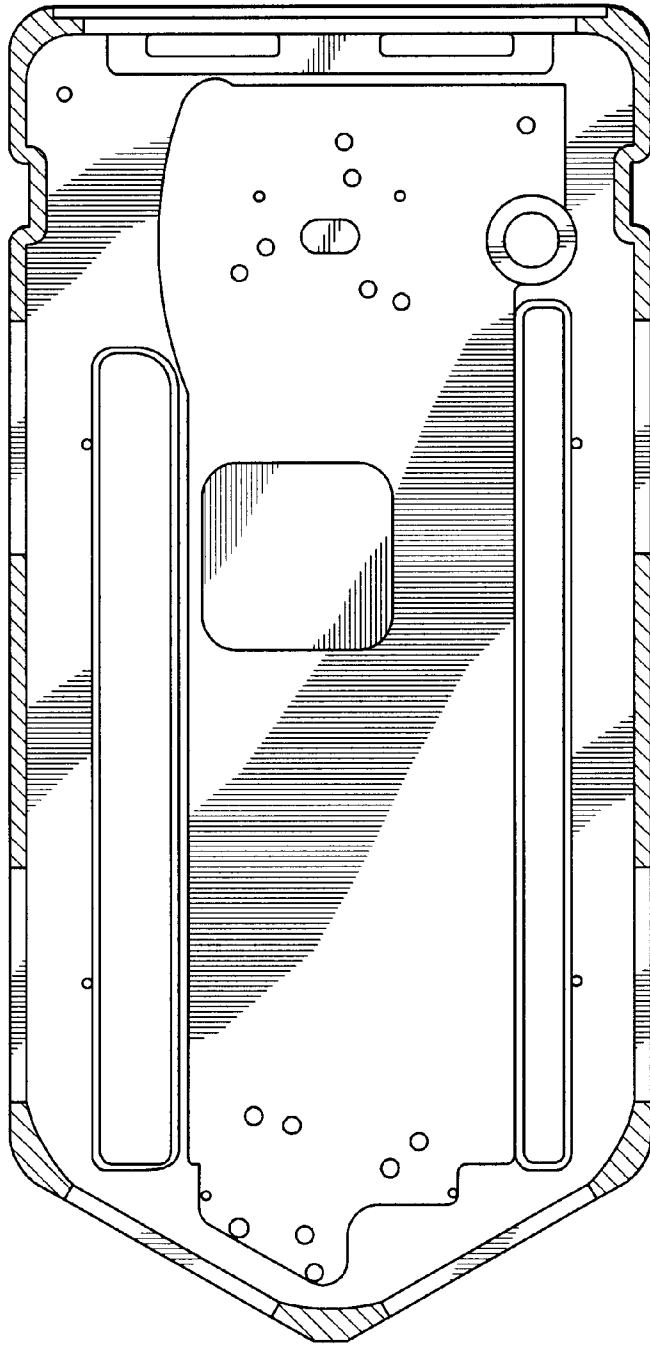

FIG. 9

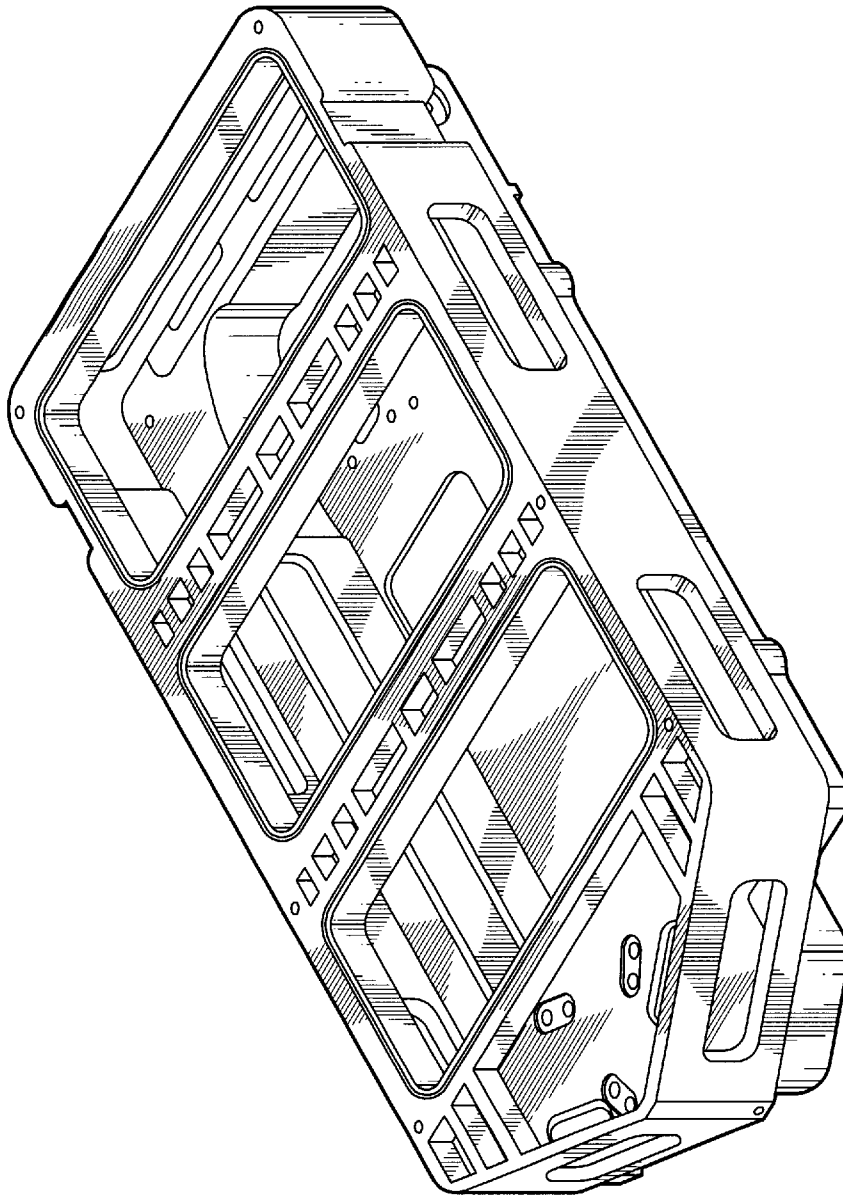

FIG.10

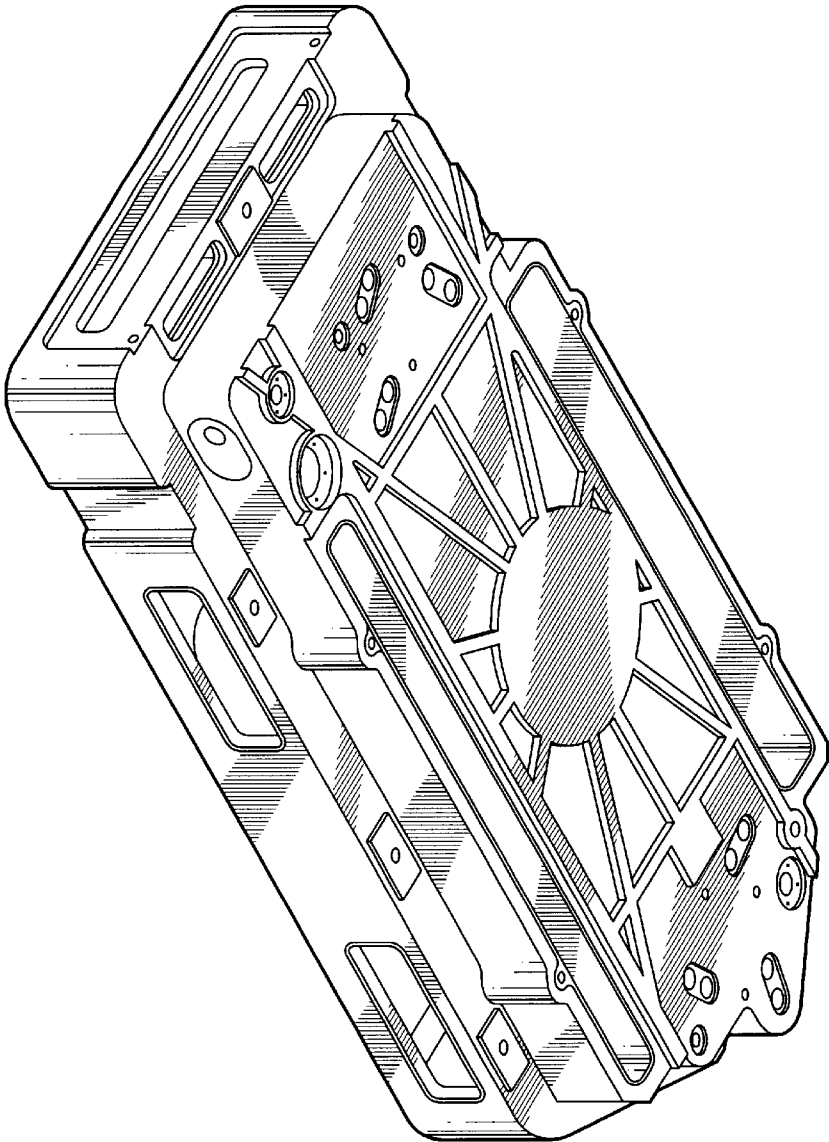

FIG.11