

C. KARK.

Gate.

No. 68,084.

Patented Aug. 27, 1867.

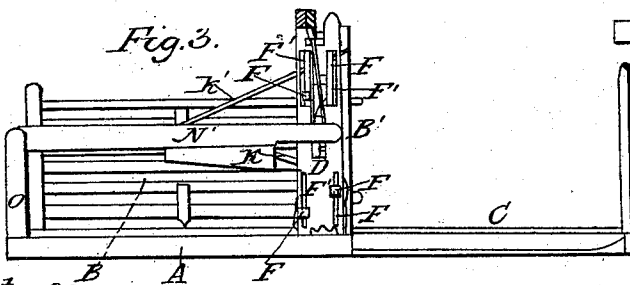
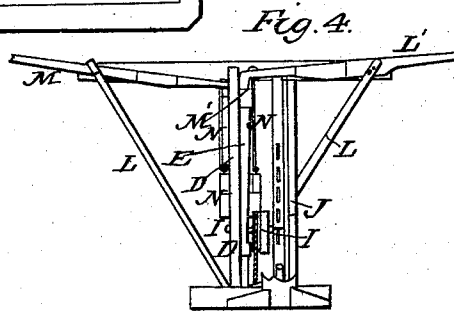
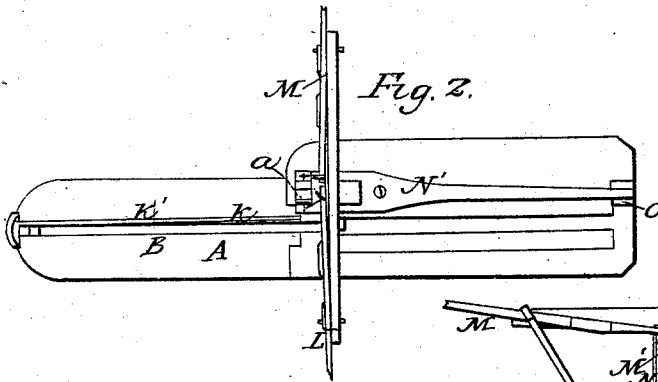
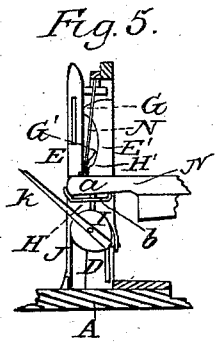
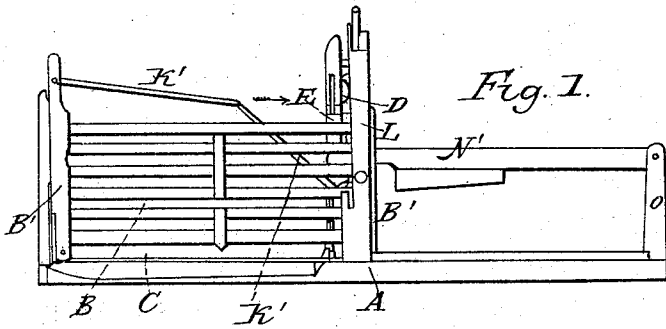

Witnesses:
H. B. Burridge
Frank S. Allen

Inventor:
C. Kark.

United States Patent Office.

CORNELIUS KARK, OF HUNTINGTON, OHIO.

Letters Patent No. 68,084, dated August 27, 1867.

IMPROVEMENT IN GATES.

The Schedule referred to in these Letters Patent and making part of the same.

TO ALL WHOM IT MAY CONCERN:

Be it known that I, C. KARK, of Huntington, in the county of Lorain, and State of Ohio, have invented certain new and useful Improvements in Self-Acting Gates; and I do hereby declare that the following is a full and complete description of the construction of the same, reference being had to the accompanying drawings, making a part of this specification, in which—

Figure 1 is a side view of the gate when closed.

Figure 2 is a view of the top.

Figure 3 is a side view of the gate when opened.

Figure 4 is an end view.

Figure 5 is a detached section.

Like letters of reference refer to like parts in the views.

In fig. 1, A is the base on which the gate B rolls in opening and shutting, and which gate is constructed in the ordinary manner, and of any required length and height. This gate runs backward and forward on rollers placed in the foot of each cross-rail or head-piece, B'. The roller at the outer end of the gate is grooved, and runs upon a raised rib or rod, C, by which the gate is guided in its movements. D, fig. 3, is a post, to which is attached a pair of carriers, E E', fig. 5, by means of lugs F, one at each end, and which are made to pass through the slots F', and in which they slide upward and downward, as will hereafter be shown. The upper end of the carriers is curved forward, forming a cam, G G', fig. 5, immediately below which project notched shoulders H H'. I, fig. 4, is a pulley, mounted upon the shaft I', having its bearings in the posts D and J. To one side of this pulley is connected the foot of the carrier E by means of the cord or chain J', fig. 5. To the other side is connected the carrier E' in the same manner. It will be observed that the ropes wind some around the pulley, thereby increasing their length, and that the relative positions of the pulley to the carriers is such as to bring them opposite on the diameter of the pulley. K is an arm fixed to the pulley, to the extreme end of which is attached the gate by means of the link K'. To the upper end of the braces L, fig. 4, are pivoted levers L' and M. The inner ends of these levers rest upon a block, M', and to which ends is suspended by the rods N the weighted lever N'. One end of this lever is pivoted to the standard O, whereas the other is forked, and embraces the post D and carriers, as seen in fig. 4. Projected across the under side of the forked end of the weighted lever is a rod, indicated by the dotted line a, fig. 2, the purpose of which will be hereafter shown.

Having thus far indicated the several parts of the gate, the practical operation of the same is as follows: The gate is supposed to be shut, as shown in fig. 1. Now, on pulling down the lever L', fig. 4, the weighted lever will be drawn upward, and when raised to the shoulder H', fig. 5, the cam G' will force the rod a over on to the shoulder, (this rod being loose and guided by the stay b.) At this time, by letting go the lever L', the weight of the lever N' will be thrown upon the carrier E', which will cause it to descend, and in so doing turn the pulley I, to which it is attached by the rope, as above said. As the pulley turns, the arm K is drawn in the direction of the arrow, fig. 1, and the gate thereby rolled back to the position shown in fig. 3. The gate is now open, and the relative positions of the two carriers reversed, the shoulder H' down and shoulder H above. It will be evident that on raising the weighted lever again by pulling down the opposite lever M, or the same as before, the cam G will push the rod a over on to the shoulder H of the carrier E, which, acting on the opposite side of the pulley, will cause it to turn reversely from that above described, and in consequence will roll the gate in the opposite direction and thus shut it, as shown in fig. 1. Thus the gate is easily and conveniently opened and shut by simply pulling down either of the levers, and which can be readily done without alighting from a horse or getting out of a carriage for that purpose.

What I claim as my improvement, and desire to secure by Letters Patent, is—

1. The carriers E E', provided with cams G G' and shoulders H H', in combination with the rope J and pulley I, as and for the purpose set forth.
2. The pulley I, arm K, and link K', as arranged in combination with the gate B, for the purpose and in the manner as described.
3. The levers L' and M, weighted lever N', and rod a, as arranged in combination with the carriers E E', and pulley I, when operated in the manner and for the purpose set forth.

Witnesses:

J. H. BURRIDGE,
J. HOLMES.

CORNELIUS KARK.