

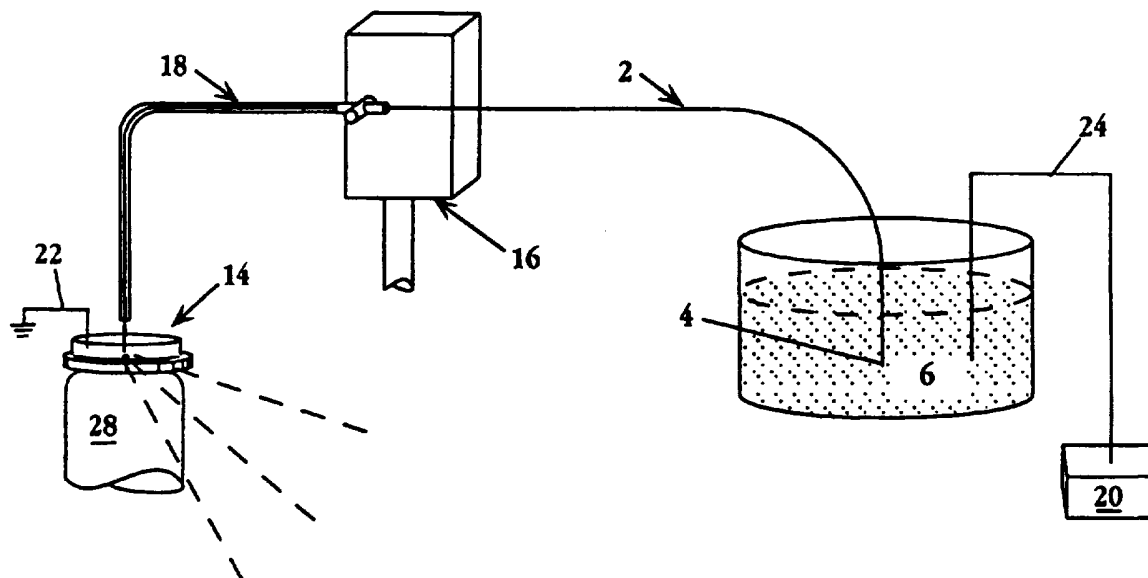

INTERNATIONAL APPLICATION PUBLISHED UNDER THE PATENT COOPERATION TREATY (PCT)

(51) International Patent Classification ⁶ : G01N 21/76	A1	(11) International Publication Number: WO 96/10170 (43) International Publication Date: 4 April 1996 (04.04.96)
<p>(21) International Application Number: PCT/US95/12444</p> <p>(22) International Filing Date: 28 September 1995 (28.09.95)</p> <p>(30) Priority Data: 08/316,036 29 September 1994 (29.09.94) US</p> <p>(71) Applicant: THE BOARD OF TRUSTEES OF THE LELAND STANFORD JUNIOR UNIVERSITY [US/US]; Stanford, CA 94305 (US).</p> <p>(72) Inventors: ZARE, Richard, N.; 724 Santa Ynez, Stanford, CA 94305 (US). SHEAR, Jason, B.; 217 Highgate Road, Ithaca, NY 14850 (US). FISHMAN, Harvey, A.; 1H Rains Apartment, Stanford, CA 94305 (US). ALLBRITTON, Nancy, L.; 22 Virgil Court, Irvine, CA 92715 (US). SCHELLER, Richard, H.; 760 Santa Ynez, Stanford, CA 94305 (US).</p> <p>(74) Agent: SHOLTZ, Charles, K.; Dehlinger & Associates, P.O. Box 60850, Palo Alto, CA 94306-1546 (US).</p>	<p>(81) Designated States: CA, JP, European patent (AT, BE, CH, DE, DK, ES, FR, GB, GR, IE, IT, LU, MC, NL, PT, SE).</p> <p>Published <i>With international search report.</i></p>	

(54) Title: CAPILLARY-BASED SEPARATION METHODS FOR IDENTIFYING BIOACTIVE ANALYTES IN A MIXTURE



(57) Abstract

Methods for detecting and methods of assaying the bioactivity of compounds and ligands, separated by capillary-based separation, such as capillary electrophoresis, from a mixture, employing an intact cell biosensor loaded with a calcium dye indicator for monitoring the bioactivity of said compounds and ligands. The figure shows an exemplary apparatus for recording optical signals from cell biosensors. Labelled parts are as follows: Number (2) functions to capillary separate ligands introduced at Number (4) the inlet end from a mixture of ligands contained in Number (6), Number (20) a power supply, (22) and (24) are electrodes, Number (16) an XYZ positioner, Number (18) a hollow needle through which the capillary is threaded into the recording chamber Number (14), the location where the response of a dye is detected via an optical detector, Number (28).

FOR THE PURPOSES OF INFORMATION ONLY

Codes used to identify States party to the PCT on the front pages of pamphlets publishing international applications under the PCT.

AT	Austria	GB	United Kingdom	MR	Mauritania
AU	Australia	GE	Georgia	MW	Malawi
BB	Barbados	GN	Guinea	NE	Niger
BE	Belgium	GR	Greece	NL	Netherlands
BF	Burkina Faso	HU	Hungary	NO	Norway
BG	Bulgaria	IE	Ireland	NZ	New Zealand
BJ	Benin	IT	Italy	PL	Poland
BR	Brazil	JP	Japan	PT	Portugal
BY	Belarus	KE	Kenya	RO	Romania
CA	Canada	KG	Kyrgystan	RU	Russian Federation
CF	Central African Republic	KP	Democratic People's Republic of Korea	SD	Sudan
CG	Congo	KR	Republic of Korea	SE	Sweden
CH	Switzerland	KZ	Kazakhstan	SI	Slovenia
CI	Côte d'Ivoire	LI	Liechtenstein	SK	Slovakia
CM	Cameroon	LK	Sri Lanka	SN	Senegal
CN	China	LU	Luxembourg	TD	Chad
CS	Czechoslovakia	LV	Latvia	TG	Togo
CZ	Czech Republic	MC	Monaco	TJ	Tajikistan
DE	Germany	MD	Republic of Moldova	TT	Trinidad and Tobago
DK	Denmark	MG	Madagascar	UA	Ukraine
ES	Spain	ML	Mali	US	United States of America
FI	Finland	MN	Mongolia	UZ	Uzbekistan
FR	France			VN	Viet Nam
GA	Gabon				

Capillary-Based Separation Methods for Identifying Bioactive Analytes in a Mixture

FIELD OF THE INVENTION

- 5 The present invention relates to methods of identifying bioactive analytes using capillary-based separation means.

REFERENCES

- Adams, S.R., *et al.*, *Nature Lond.* 349:694 (1991).
- 10 Altria, K., and Simpson, C., *Anal. Proc.* 23:453 (1986).
- Arai, H., *et al.*, *Nature* 348:730 (1990).
- Ausubel, F.M., *et al.*, CURRENT PROTOCOLS IN MOLECULAR BIOLOGY, John Wiley and Sons, Inc., Media PA.
- Avila, L.Z., *et al.*, *J. Med. Chem.* 36:126 (1993).
- 15 Balchunas, A.T., and Sepaniak, *Anal. Chem.* 59:1470 (1987).
- Balchunas, A.T., and Sepaniak, *Anal. Chem.* 60:617 (1988).
- Bard, A.J., and Faulkner, L.R., ELECTROCHEMICAL METHODS: FUNDAMENTALS AND APPLICATIONS (J. Wiley & Sons, New York) (1980).
- Barnard, E.A., *et al.*, "Cloned Genes for Ligand-Operated Ion Channels and Their
- 20 Expression *In Vitro*" in THE BIOLOGY AND MEDICINE OF SIGNAL TRANSDUCTION (Nishizuka, Y., *et al.*, eds.) (Raven Press, NY), p. 20 (1990).
- Bean, B.P., *et al.*, "ATP-Activated Channels in Excitable Cells" In ION CHANNELS, VOL. 2, T. Narahashi, ed., (Plenum, New York) (1990).
- Berry, V., *LC/GC* 6:484 (1988).
- 25 Berry, V., *et al.*, in PROCEEDINGS OF THE TENTH INTERNATIONAL SYMPOSIUM ON CAPILLARY CHROMATOGRAPHY (Sandra, P. and Redant, G., eds., Alfred Huethig Publishing, Heidelberg, Germany) (1989).
- Berry, V., *et al.*, *J. Liq. Chromatography* 13:1529 (1990).
- Bocek, P., *et al.*, ANAL. ISOTACHOPHORESIS (VCH Verlagsgesellschaft, Weinheim)
- 30 (1988).
- Boekhoff, *et al.*, *EMBO J.* 9:2453 (1990).
- Breer, H., *et al.*, *Nature* 345:65 (1990).
- Briggs, C.A., *et al.*, *Br. J. Pharmacol.* 104:1038 (1991).
- Bright, *et al.*, *BioTechniques* 5:556-563 (1987).

- Bright, G.R., *et al.*, "Fluorescence ratio imaging microscopy" in FLUORESCENCE MICROSCOPY OF LIVING CELLS IN CULTURE. METHODS IN CELL BIOLOGY (Taylor, D.L. and Wang, Y.-L., eds.) (Academic Press, San Diego) pt. B, vol 30:157 (1989).
- Bruno, *et al.*, *Appl. Spec.* 45:462 (1991).
- 5 Buck, L., *et al.*, *Cell* 65:175 (1991).
- Burton, D.E., *et al.*, *Chromatographia* 21:583 (1986).
- Bush, A.B., *et al.*, *J. Neurochem.* 57:562 (1991).
- Carpenter, G., *et al.*, *Annu. Rev. Biochem.* 48:193 (1979).
- Chen, C., *et al.*, *Mol. Cell Biol.* 7:2745 (1987).
- 10 Chen, *et al.*, *Appl. Spectroscopy* 42:515-518 (1988).
- Chen, *et al.*, *Anal. Chem.* 61:1590-1593 (1989).
- Chien, J.B., and Ewing, A.G., Abstract N° 352, 1988 Pittsburgh Conference and Exposition (1988).
- Chin, A.M., U.S. Patent No. 5,110,424 for "Nucleic Acid Fractionation by Counter-
- 15 Migration Capillary Electrophoresis," issued May 5, 1992.
- Chinkers, M., *et al.*, *Nature* 338:78 (1989).
- Christensen, *et al.*, *Anal. Chem.* 61:1344-47 (1989).
- Chu, Y-H, *et al.*, *J. Med. Chem.* 35:2915 (1992).
- Chu, Y-H, *et al.*, *J. Org. Chem.* 58:648 (1993).
- 20 Claudio, T., *et al.*, *PNAS* 84:5967 (1987a).
- Claudio, T., *et al.*, *Science* 238:1688 (1987b).
- Cohen, A.S., *et al.*, *Chromatographia* 24:14 (1987a).
- Cohen, A.S., *et al.*, *Anal. Chem.* 59:1021 (1987b).
- Cohen, A.S., and Karger, B.L., *J. Chromatogr.* 397:409 (1987c).
- 25 Cohen, A.S., *et al.*, U.S. Patent No. 5,122,248 for "Pulsed Field Capillary Electrophoresis; Apparatus for Separating and Detecting Molecular Species," issued June 16, 1992.
- Cohen, L.B., *J. Membrane Biol.* 19:1 (1974).
- Cohen, M.L., *et al.*, *Am. J. Physiol.* 257:H681 (1989).
- 30 Colburn, J.C., "Capillary Electrophoresis Separations of Peptides: Practical Aspects and Applications" in CAPILLARY ELECTROPHORESIS: THEORY AND PRACTICE (Grossman, P.D., and Colburn, J.C., eds., Academic Press, Inc., New York) (1992).
- Conn, P.M., ed., METHODS IN NEUROSCIENCES, VOL. 3. QUANTITATIVE AND QUALITATIVE MICROSCOPY (Academic, San Diego, CA) (1990).

- Conn, P.M., ed., METHODS IN NEUROSCIENCES, VOL. 4. ELECTROPHYSIOLOGY AND MICROINJECTION (Academic, San Diego, CA) (1991a).
- Conn, P.M., ed., METHODS IN NEUROSCIENCES, VOL. 5. NEUROPEPTIDE TECHNOLOGY, GENE EXPRESSION & PEPTIDE RECEPTORS (Academic, San Diego, CA) (1991b).
- 5 Cooper, J.R., *et al.*, The Biochemical Basis of Neuropharmacology, 5th ed. (Oxford University Press, New York) (1986).
- Dascal, N., *et al.*, *PNAS* 90:6596 (1993).
- DeLorme, E.M., and McGee, R., Jr., *J. Neurochem.* 50(4):1248 (1988).
- Demarest, C.W., *et al.*, "Separation of Small Molecules by High-Performance
10 Capillary Electrophoresis" in CAPILLARY ELECTROPHORESIS: THEORY AND PRACTICE (Grossman, P.D., and Colburn, J.C., eds., Academic Press, Inc., New York) (1992).
- Deml, M., *et al.*, *J. Chromatogr.* 320:159 (1985).
- Demorest, D.M., *et al.*, U.S. Patent No. 5,264,101 for "Capillary Electrophoresis Molecular Weight Separation of Biomolecules Using ...," issued November 23, 1993.
- 15 deWeer, P. and B. Salzberg, eds., OPTICAL METHODS IN CELL PHYSIOLOGY (Wiley, New York) (1986).
- Dubrow, R.S., "Capillary Gel Electrophoresis" in CAPILLARY ELECTROPHORESIS: THEORY AND PRACTICE (Grossman, P.D., and Colburn, J.C., eds., Academic Press, Inc., New York) (1992).
- 20 Duchen, M.R., "Fluorescence - monitoring cell chemistry *in vivo*" in MONITORING NEURONAL ACTIVITY (Staford, J.A., ed.) (Oxford University Press, London), pp. 231 (1992).
- Eaton, D.L., *et al.*, *Biochemistry* 25:8343 (1986).
- Ellis, L., *et al.*, *Cell* 45:721 (1986).
- Elroy-Stein, O., *et al.*, *PNAS* 86:6126 (1989).
- 25 Everaerts, F.M., *et al.*, ISOTACHOPHORESIS: THEORY, INSTRUMENTATION, AND APPLICATIONS (Elsevier, Amsterdam) (1976).
- Ewing, *et al.*, *Anal. Chem.* 61:292A (1989)
- Fasolato, P., *et al.*, *J. Biol. Chem.* 265:20351 (1990).
- Fishman, H., *et al.*, *Anal. Chem.* 66:2318 (1994).
- 30 Forda, *et al.*, *Brain Res.* 249:371 (1982).
- Foret, F., *et al.*, *Electrophoresis* 7:430 (1986).
- Fuerst, T.R., *et al.*, *PNAS* 83:8122 (1986).
- Fujisawa, S., and Honda, S., *Anal. Chem.* 58:1811 (1986).
- Gassman, E., *et al.*, *Science* 230:813 (1985).

- Goeddel, D.V., ed. GENE EXPRESSION TECHNOLOGY (Academic Press, New York) (1991).
- Gomez, F.A., *et al.*, *Anal. Chem.* 66:1785 (1994). Gordon, M.J., *et al.*, *Science* 242:224 (1988).
- 5 Gould, G.W., ed., MEMBRANE PROTEIN EXPRESSION SYSTEMS - A USERS GUIDE (Ashgate Pub. Co.) (1993).
- Gozel, P., *et al.*, *Anal. Chem.* 59:44 (1987).
- Green, J.S., and Jorgenson, J.W., *J. Chromatogr.* 352:337 (1986).
- Greene, L.A., *et al.*, *PNAS* 73:2424 (1976).
- 10 Greene, L.A., *et al.*, *Nature* 268:349 (1977).
- Greene, L.A., *et al.*, In CULTURING NERVE CELLS, G. Banker and K. Goslin, eds., (MIT Press, Cambridge, MA) (1991).
- Gregory, R.J., *et al.*, *Nature* 347:382 (1990).
- Gross, *et al.*, *J. Neurosci. Meth.* 15:243 (1985).
- 15 Grossman, P.D., and Colburn, J.C., eds., CAPILLARY ELECTROPHORESIS: THEORY AND PRACTICE (Academic Press, Inc., New York) (1992).
- Grossman, P.D., U.S. Patent No. 5,126,021 for "Low-Viscosity Polymer Solution for Capillary Electrophoresis," issued June 30, 1992.
- Gryniewicz, G., *et al.*, *J. Biol. Chem.* 260:3440 (1985).
- 20 Gunderson, C.B., *et al.*, *Proc. R. Soc. London Ser. B.* 219:103 (1983).
- Gupta, R.K., *J. Membrane Biol.* 58:123 (1981).
- Gurdon, *et al.*, *Nature* 233:177 (1971).
- Guttman, A., U.S. Patent No. 5,332,481 for "Capillary Electrophoresis Using Replaceable Gels," issued July 16, 1994.
- 25 Hahn, K., *et al.*, *J. Biol. Chem.* 265(33):20335 (1990).
- Hahn, K., *et al.*, *Nature* 359:736 (1992).
- Hamill, O.P., *et al.*, *Pflugers Arch.* 391:85 (1981).
- Harootunian, A.T., *et al.*, *Cold Spring Harbor Symp. Quant. Biol.* 53:935 (1988).
- Harootunian, A.T., *et al.*, *Cell Calcium* 12:153 (1991a).
- 30 Harootunian, A.T., *et al.*, *Science Wash. D.C.* 251:75 (1991b).
- Herman, B. and K. Jacobson, eds., OPTICAL MICROSCOPY FOR BIOLOGY (Wiley-Liss, New York) (1990).
- Hershey, A.D., and Krause, J.E., *Science* 247:958 (1990).

- Hille, B., IONIC CHANNELS OF EXCITABLE MEMBRANES, 2ND EDITION (Sinauer, Sunderland, MA) (1992).
- Hirati, M., *et al.*, *Nature* 349:617 (1991).
- Hjertén, S., *J. Chromatogr.* 270:1 (1983).
- 5 Hjertén, S., and Zhu, M.D., *J. Chromatogr.*, 327:157 (1985a).
- Hjertén, S., and Zhu, M.D., *J. Chromatogr.* 346:265 (1985b).
- Hjertén, S., and Zhu, M.D., *Protides Biol. Fluids* 33:537 (1985c).
- Hjertén, S., *et al.*, *J. Chromatogr.* 387:127 (1987a).
- Hjertén, S., *et al.*, *J. Chromatogr.* 403:47 (1987b).
- 10 Hollmann, M., *et al.*, *Nature* 342:643 (1989).
- Holmes, W.E., *et al.*, *Science* 253:1278 (1991).
- Houghten, R.A., *Current Biology* 4:564 (1994).
- Huang, X., *et al.*, *Anal. Chem.* 59:2747 (1987).
- Huang, X., *et al.*, *Anal. Chem.* 60:375 (1988a).
- 15 Huang, X., *et al.*, *J. Chromatogr.* 425:385 (1988b).
- Jackson, T., *Pharmacol. Ther.* 50:425 (1991).
- Johnson, W.S., *et al.*, U.S. Patent No. 5,312,535 for "Capillary Electrophoresis Detection" issued May 17, 1994.
- Jorgenson, J.W., and Lukacs, K.D., *Anal. Chem.* 53:1298 (1981a).
- 20 Jorgenson, J.W., and Lukacs, K.D., *J. Chromatogr.* 218:209 (1981b).
- Jorgenson, J.W., and Lukacs, K.D., *Science* 222:266 (1983).
- Jorgenson, J.W., *Trends Anal. Chem.* 3:51 (1984).
- Jorgenson, J.W., and Lukacs, K.D., *J. High Resolut. Chromatogr. Chromatogr. Commun.* 8:407 (1985).
- 25 Jorgenson, J.W., and Lukacs, K.D., *Clin. Chem. (Winston-Salem, NC)* 27:1551 (1987).
- Julius, D., *et al.*, *Science* 241:558 (1988).
- Jumblatt, J.E., *et al.*, *Nature* 297:152 (1982).
- Kao, *et al.*, *J. Biol. Chem.* 264:8179 (1989).
- 30 Kito, S., ed., NEURORECEPTORS & SIGNAL TRANSDUCTION (Plenum Press, New York) (1988).
- Knox, J.H., *Chromatographia* 26:329 (1988).
- Kriegler, M., GENE TRANSFER AND EXPRESSION: A LABORATORY MANUAL (Oxford University Press, Oxford) (1991).

- Lakowicz, J.R., PRINCIPLES OF FLUORESCENCE SPECTROSCOPY (Plenum, New York) (1983).
- Lauer, H.H., and McManigill, *Anal. Chem.* **58**:166 (1986).
- Leonard, J.P. and T.P. Snutch, "The Expression of Neurotransmitter Receptors and
5 Ion Channels in *Xenopus* Oocytes" in MOLECULAR NEUROBIOLOGY. A PRACTICAL APPROACH
Chad, J. and H. Wheal, eds., (IRL Press, New York) (1991).
- Leonard, J.P., *et al.*, *PNAS* **85**:7629 (1989).
- Li, S.F.Y. "Capillary Electrophoresis: Principles, Practice and Applications", in
JOURNAL OF CHROMATOGRAPHY LIBRARY VOL. 52 (Elsevier, Amsterdam) (1992).
- 10 Loew, L.M., *et al.*, *Membrane Biol.* **130**:1 (1992).
- Mack, L.L., *et al.*, *J. Chem. Phys.* **52**:4977 (1970).
- Mazzeo, J.R., and Verheggen, P.E.M., "New Directions in Electrophoretic Methods
(Jorgenson, J.W., and Phillips, M., eds.) *Amer. Chem. Soc. Symp.* **335**:Chapter 4
(Washington, D.C.) (1987).
- 15 McEachern, *et al.*, *PNAS* **88**:7724 (1991).
- Meguro, H., *et al.*, *Nature* **357**:70 (1992).
- Meister, M., *et al.*, *J. Neurosci. Meth.* **51**:95 (1994).
- Minta, A., and Tsien, R.Y., *J. Biol. Chem.* **264**:19449 (1989).
- Monnig, C. A., *et al.*, *Anal. Chem.* **66**:280R (1994).
- 20 Monyer, H., *et al.*, *Science* **256**:1217 (1992).
- Mori, M., *et al.*, *J. Biol. Chem.* **263**:14574 (1988).
- Murphy, P.M., and Tiffany, H.L., *Science* **253**:1280 (1991).
- Nakanishi, S., *Science* **258**:597 (1992).
- Nicoll, *et al.*, *Neuron* **1**:97 (1988).
- 25 Olivares, J.A., *et al.*, *Anal. Chem.* **59**:1230 (1987).
- Olivera, B.M., *et al.*, *Science* **230**:1338 (1985).
- Otsuka, K., *et al.*, *J. Chromatogr.* **332**:219 (1985).
- Permentier, M., *et al.*, *Nature* **355**:453 (1992).
- Peters, J.A., *et al.*, "Physiological and Pharmacological Aspects of 5-HT₃ Receptor
30 Function" In ASPECTS OF SYNAPTIC TRANSMISSION, VOL. 1, T. Stone, ed. (Francis and
Taylor, London) (1991).
- Pine, J., *J. Neurosci. Meth.* **2**:19 (1980).

- Poenie, M., "Measurement of intracellular calcium with fluorescent calcium indicators" in NEUROMETHODS. INTRACELLULAR MESSENGERS (Boulter, A., *et al.*, eds.) (Humana, Clifton, NJ) Vol. 20:129 (1992).
- Pozzan, T., *et al.*, *Biochem. J.* 234:547 (1986).
- 5 Pretorius, V., *et al.*, *J. Chromatogr.* 99:23 (1974).
- Pritchett, D.B., *et al.*, *Science* 242:1306 (1989).
- Raming, K., *et al.*, *Nature* 361:353 (1993).
- Reuveny, E., *et al.*, *Nature* 370:143 (1994).
- Rich, D.P., *et al.*, *Nature* 347:358 (1990).
- 10 Rink, T.J., *et al.*, *J. Cell Biol.* 95:189 (1982).
- Roach, M.C., *et al.*, *J. Chromatogr.* 426:129 (1988).
- Rose, D.J., Jr., and Jorgenson, J.W., *Anal. Chem.* 60:642 (1988).
- Ross, W.N., *et al.*, *J. Membrane Biol.* 33:141 (1977).
- Sakmann, B. and E. Neher, eds., SINGLE CHANNEL RECORDING (Plenum Press, New
15 York) (1983).
- Sakurai, T., *et al.*, *Nature* 348:732 (1990).
- Sambrook, J., *et al.*, MOLECULAR CLONING: A LABORATORY MANUAL, Cold Spring Harbor Laboratory Press, Vol. 2 (1989).
- Sands, S.B., *et al.*, *Brain Res.* 560:38 (1991).
- 20 Sargent, P.B., *Annu. Rev. Neurosci.* 16:403 (1993).
- Scheuer, T., *et al.*, *Science* 247:854 (1990).
- Sepaniak, M.J., and Cole, R.O., *Anal. Chem.* 59:472 (1987).
- Shafer, T.J., and Atchison, W.D., *NeuroToxicol.* 12:473 (1991).
- Shirasaki, Y.I., U.S. Patent No. 5,147,517 for "Method of Capillary Electrophoresis;
25 Buffer, Ungelled Agarose," issued September 15, 1992.
- Slavik, FLUORESCENT PROBES IN CELLULAR AND MOLECULAR BIOLOGY (CRC Press, Boston) (1994).
- Smith, R.D., *et al.*, *Anal. Chem.* 60:436 (1988).
- Smith, T.G., and P.W. Gage, eds., VOLTAGE AND PATCH CLAMPING WITH
30 MICROELECTRODES (American Physiological Society) (1985).
- Stryer, L., BIOCHEMISTRY, 3RD EDITION (W.H. Freeman, New York) (1988).
- Tanasugarn, L., *et al.*, *J. Cell Biol.* 98:171 (1984).
- Taylor, D.L., *et al.*, (eds.), APPLICATIONS OF FLUORESCENCE IN THE BIOMEDICAL
SCIENCES (Alan R. Liss, Inc., New York) (1986).

- Taylor, D.L. and Y.-L. Wang (eds.) *Fluorescence Microscopy of Living Cells in Culture, parts A and B. METHODS IN CELL BIOLOGY*, Vol. 30, Academic Press, New York (1989).
- Taylor, D.L., *et al.*, *American Scientist* **80**:322-335 (1992).
- 5 Taylor, S.S., *et al.*, *Ann. Rev. Biochem.* **59**:971 (1990).
- Teichberg, V., and U.F. Habenicht, eds., EXCITATORY AMINO ACIDS & SECOND MESSENGER SYSTEMS (Springer Verlag, New York) (1992).
- Terabe, S., *et al.*, *Anal. Chem.* **56**:111 (1984).
- Terabe, S., *et al.*, *Anal. Chem.* **57**:825 (1985).
- 10 Terabe, S., *et al.*, *Anal. Chem.* **61**:251 (1989).
- Tsien, R.Y., *Biochemistry* **19**:2396 (1980).
- Tsien, R.Y., *Nature Lond.* **290**:527 (1981).
- Tsien, R.Y., *Annu. Rev. Neurosci.* **12**:227 (1989a).
- Tsien, R.Y., *Methods Cell Biol.* **30**:127 (1989b).
- 15 Tsien, R.Y., *Am. J. Physiol.* **263**:(*Cell Physiol.* **32**):C723 (1992).
- Tsuda, T., *et al.*, *Anal. Chem.* **59**:799 (1987).
- Tsuda, T., *et al.*, *J. Chromatogr.* **248**:241 (1982).
- Tsuda, T., *et al.*, *J. Appl. Biochem.* **5**:330 (1983a).
- Tsuda, T., *et al.*, *J. Chromatogr.* **264**:385 (1983b).
- 20 Tsuda, T., *J. High Resolut. Chromatogr. Chromatogr. Comm.* **10**:622 (1987).
- Tsuda, T., *et al.*, U.S. Patent No. 5,141,621 for "Capillary Electrophoresis Injection Device and Method; Split Interface for Insertion...", issued August 15, 1992.
- Walbroehl, Y., and Jorgenson, J.W., *J. Chromatogr.* **315**:135 (1984).
- Walbroehl, Y., and Jorgenson, J.W., *Anal. Chem.* **58**:479 (1986).
- 25 Wallingford, R.A., and Ewing, A.G., *Anal. Chem.* **59**:678 (1987a).
- Wallingford, R.A., and Ewing, A.G., *Anal. Chem.* **59**:1762 (1987b).
- Wallingford, R.A., and Ewing, A.G., *Anal. Chem.* **60**:258 (1988).
- Wallis, D.I., ed., *Electrophysiology. A Practical Approach.* (IRL Press, New York) (1993).
- 30 Wang, H.-C., *et al.*, *Int. J. Biochem.* **23**(3):271 (1991).
- Wells, A., in ONCOGENES, C. Benz and E. Lui, eds., (Kluwer Academic, Boston) (1989).
- White, *et al.*, *PNAS* **82**:4852 (1985).
- Whitehouse, C.M., *et al.*, *Anal. Chem.* **57**:675 (1985).

Wiktorowicz, J.E., U.S. Patent No. 5,181,999 for "Capillary Electrophoresis Method with Polymer Tube Coating," issued January 26, 1993.

Wiktorowicz, J.E., and Colburn, J.C., "Protein Analyses by Capillary Electrophoresis" in CAPILLARY ELECTROPHORESIS: THEORY AND PRACTICE (Grossman, P.D., and Colburn, J.C., eds., Academic Press, Inc., New York) (1992).

Yamamoto, K., *et al.*, *J. Chromatogr.* 588:327 (1991).

Zagotta, W.N., *et al.*, *PNAS* 86:7243 (1989).

BACKGROUND OF THE INVENTION

10 Capillary-based separation means, or methods, have been employed to resolve small volumes containing complex mixtures of analytes into their constituents. Methods based on the principle of capillary electrophoresis are particularly effective in this regard (Jorgenson, *et al.*, 1983, Gordon, *et al.*, Ewing, *et al.*). In capillary electrophoresis, an electric field is applied across a capillary, typically about 10 to 100 cm long and 20-200 μm in internal diameter, that
15 contains a separation medium, typically an electrolyte or gel. The electric field induces electroosmotic flow of the separation medium through the capillary, and causes analytes in a sample mixture to separate according to, among other factors, their charge and hydrodynamic drag.

Detection methods that have been used with capillary electrophoresis include optical
20 absorption (*e.g.*, Lauer, *et al.*), optical fluorescence (*e.g.*, Gassman, *et al.*, electrochemical (*e.g.*, Wallingford, *et al.*, 1987b), conductimetric detection (*e.g.*, Huang, *et al.*, 1987), radioisotope based detection (*e.g.*, Berry), refractive index changes (*e.g.*, Bruno, *et al.*) and mass spectrometry (Olivares, *et al.*).

The present invention provides a method of separating small volumes of complex
25 mixtures of analytes using capillary-based separation means, and identifying separated constituents using a highly sensitive and highly selective detection means distinct from the above.

SUMMARY OF THE INVENTION

30 In one aspect, the present invention includes a method for detecting a selected ligand in a mixture of ligands. The method includes separating the mixture of ligands containing the selected ligand using a separation means, delivering separated ligands to a cell biosensor having a receptor capable of binding the selected ligand, and detecting binding of the selected ligand to the receptor. In a preferred embodiment, the separation means is a capillary-based

separation means, and the separated ligands are delivered to said biosensor in a cell biosensor compatible buffer.

The separated ligands are preferably delivered to a cell biosensor that is adjacent the outlet of the capillary-based separation means.

5 A ligand may be any analyte that is capable of binding to a receptor and, by binding, having a measurable effect on the receptors's activity or function. In one embodiment, the mixtures of ligands is derived from a tissue extract. In a related embodiment, the mixture is derived from a cell extract. In yet another embodiment, the mixture of ligands is obtained from a combinatorial library of ligands. Selected ligands in a mixture of ligands may include
10 such compounds as acetylcholine, bradykinin and ATP. Further, selected ligands may include a "parent" ligand, and breakdown, proteolysis or degradation products of that parent. Alternatively, the ligands may be a selected subset of degradation products. In one embodiment, the ligand may be an agonist of the receptor, while in another, it may be an antagonist.

15 According to another aspect of the present invention, the separation means used in methods of the present invention is one of, or a combination of, various modes of capillary electrophoresis, including capillary zone electrophoresis, capillary gel electrophoresis, capillary electrochromatography, capillary isotachopheresis, affinity capillary electrophoresis, micellar electrokinetic capillary electrochromatography, capillary isoelectric focusing. The separation
20 means may also be a variation of micro liquid chromatography, such as open tube liquid chromatography.

In another aspect, a cell biosensor used in methods of the present invention may be a cell, including a cell recombinantly expressing a specific receptor. In one embodiment, the cell biosensor is a eukaryotic cell, such as a mammalian cell or a *Xenopus* oocyte. In another
25 embodiment, the cell biosensor is a cell in contact with a voltage-recording electrode, such as an extracellular electrode, intracellular voltage-recording electrode, intracellular voltage clamp electrode(s), whole-cell patch electrode, or cell-attached patch electrode. In a related embodiment, the cell biosensor is a cell having a cell condition reporter, such as a dye sensitive to voltage, calcium, cAMP, calmodulin, pH, sodium, chloride, magnesium, or the like. Such
30 reporters would detect changes in the cell biosensor in voltage, intracellular free calcium, cAMP, activated calmodulin, pH, sodium chloride and magnesium, respectively. In another related embodiment, the cell biosensor is a group of cell, such as a group of confluent or semi-confluent cells. In a further embodiment, the cell biosensor is a portion of an intact cell, such as an inside-out or outside-out membrane patch, a permeabilized cell, or a cellular organelle,

such as a vesicle containing membrane from, for example, the sarcoplasmic reticulum of muscle.

In still another aspect of the present invention, the cell biosensor is in a bathing solution containing a receptor-specific antagonist, and effects of the presence of the agonist on the cell biosensor response are evaluated. According to this aspect of the invention, specific
5 identification of ligand-bound receptors is possible. In a related embodiment, the cell biosensor is exposed to a receptor agonist while, for example, separated ligands thought to function as receptor antagonists are delivered with a capillary-based separation means.

The invention also includes the cell biosensor attached at the outlet end of the capillary
10 used in the capillary-based separation means. The biosensors may be cells that were transferred to the outlet tip of the capillary by touching the tip to a cell in a recording chamber. Alternatively, the cell biosensor may be cells cultured and grown directly in the outlet tip of a capillary that is subsequently used for a capillary-based separation means. In a related embodiment, the cell biosensors are, for example, cells grown on a solid support, and the solid
15 support containing the cells is attached, preferably removably, at the outlet end of the capillary.

Another aspect of the invention relates to moving either the cell biosensor or the outlet tip of the capillary with respect to the other to employ a different biosensor during the course of separation. This embodiment can minimize effects of receptor desensitization on cell biosensor responses or signals. The movement may be step-wise, such that a rapid translation
20 is made to a region of substrate containing a different biosensor, and the region is recorded from for a set period of time, or the movement may be continuous, such that the cell biosensor detection field and the capillary eluent sweep across a substrate containing cell biosensors. The rate of sweep may be set such that receptors do not desensitize appreciably before they are out of the biosensor detection field.

Also forming part of the methods of the present invention are supplemental detection
25 means used in conjunction with a cell biosensor to identify ligands present in a mixture of ligands. According to this aspect of the invention, "peaks" of analytes are identified whether or not they have biological activity, and biological activity may be correlated with specific peaks detectable by traditional capillary electrophoresis methods. Preferably, the supplemental
30 detection means does not interfere with or disturb the separated ligands as they pass through a capillary of a capillary-based separation means. For example, an optically-clear window may be incorporated in the capillary a few centimeters upstream of the outlet end of the capillary, and used for monitoring the fluorescence or UV-absorbance of the separated ligands as they pass by the window, and just before they exit the outlet and are introduced to the cell

biosensor. The outputs from the various detection means, including cell biosensor signal detection means, may be routed to a computer programmed for various types of analyses, such as correlation of the peaks detected with a supplemental detection device and peaks detected with the cell biosensor.

5 The invention further includes a kit for supplying cell biosensors for use with a capillary-based separation means of the present invention. In one embodiment, the cell biosensors are supplied on a solid support that can be attached at the outlet end of a capillary-based separation means. The kit may include a plurality of such solid supports, frozen cells suitable for thawing and culturing on the solid supports, and various devices to facilitate the
10 growing of cells on the solid supports, such as a culture chamber, adapted to receive a plurality of solid supports containing cells, for growing the cells.

In another aspect, the invention includes a device for performing capillary-based separations in conjunction with a cell biosensor. The device may include a capillary-based separation means, including capillaries, a power supply, solution/electrolyte reservoirs, and the
15 like, and cell biosensors. The device may be designed to be used with a kit as described above, and may further be automated, for example, to introduce a plurality of samples sequentially to the inlet end of the capillary, and/or to replace cell biosensors, as needed, at the outlet end of the capillary.

20 These and other objects and features of the invention will be more fully appreciated when the following detailed description of the invention is read in conjunction with the accompanying drawings.

BRIEF DESCRIPTION OF THE FIGURES

25 Figures 1A and 1B show schematic diagrams of a capillary electrophoresis apparatus in conjunction with a cell biosensor and an optical detector used for detecting the state or condition of a cell condition reporter in the cell biosensor.

Figure 1C shows a photomicrograph of the end of a capillary with its internal channel positioned above a cell biosensor (labeled "cell").

30 Figure 2 shows plots of fluorescence as a function of time detected from cell biosensors following capillary electrophoresis separation of ligands including acetylcholine (ACh), bradykinin (BK) and adenosine triphosphate (ATP).

Figure 3 shows plots of fluorescence as a function of time detected from cell biosensors following capillary electrophoresis separation of a lysate of PC12 cells and a control including acetylcholine.

Figure 4 shows a schematic diagram of a two-electrode oocyte voltage clamp in conjunction with a portion of a capillary electrophoresis apparatus.

Figure 5 shows plots of current as a function of time passed by a two electrode voltage clamp to maintain an oocyte, recombinantly expressing a serotonin receptor, at -70 mV in the presence of delivery of separated ligands including serotonin.

Figures 6A, 6B, 6C and 6D show plots of fluorescence as a function of time detected from cell biosensors following capillary electrophoresis separation of pulses of bradykinin, illustrating (i) the desensitization of bradykinin receptors expressed on a cell biosensor (Figs. 6A, 6B, 6C and 6D), (ii) normal bradykinin responses on neighboring cell biosensors (Figs. 6B, 6C and 6D), (iii) translating the substrate containing the biosensors with respect to a stationary capillary (Fig. 6B), and (iv) translating the capillary with respect to distinct stationary biosensors (Figs. 6C and 6D).

Figure 7 shows plots of fluorescence as a function of time detected from a cell biosensor following capillary electrophoresis separation of a mixture of ligands containing acetylcholine and bradykinin in the presence and absence of HOE 140 (a bradykinin receptor antagonist).

Figures 8A and 8B show plots of fluorescence as a function of time detected from a cell biosensor following capillary electrophoresis separation of a mixture of ligands containing acetylcholine and bradykinin in the presence (Fig. 8B) and absence (Fig. 8A) of atropine and α -bungarotoxin (acetylcholine receptor antagonists).

Figure 9 shows a plot of fluorescence as a function of time detected from a cell biosensor following capillary electrophoresis separation of a mixture of ligands containing acetylcholine, bradykinin and Lys-bradykinin.

DETAILED DESCRIPTION OF THE INVENTION

I. DEFINITIONS

A "capillary-based separation means" refers to any method for separating a mixture of analytes that employs a capillary as the entity in which the separation occurs. Examples include variations of capillary electrophoresis, including capillary zone electrophoresis, capillary gel electrophoresis, micellar electrokinetic capillary electrochromatography, capillary

isoelectric focusing, capillary isotachopheresis, and affinity capillary electrophoresis, as well as variations of micro liquid chromatography, such as open tube liquid chromatography.

A "capillary" refers to a tube having an inner diameter of between about 5 μm and about 1 mm. Preferably, the inner diameter is between about 20 μm and about 200 μm . The length of the capillary may be between about 1 cm and about 2 m, but is typically in the range of tens of centimeters. The capillary is typically made of a glass or fused silica material, but may be made from other materials as well, including various plastics. The inner and outer surfaces of the capillary may further be coated with any of a variety of materials to improve separation, reduce electrical noise, or alter other selected characteristics.

10 A "cell biosensor" refers to an intact cell, a portion of an intact cell (such as a membrane patch or permeabilized cell), or an intact cell in electrical communication with electrode(s) (such as intracellular recording electrodes, whole-cell electrodes, cell-attached patch electrodes, extracellular recording electrodes, etc.). In the case of a cell in electrical communication with an extracellular electrode, it will be understood that the cell does not necessarily need to be in contact with the electrode, only that the electrode be capable of detecting changes in the electric field due to changes in the cell's transmembrane electrical potential. It will also be understood that a cell biosensor designed for use with an optical detection system (see below) will typically contain a cell condition reporter detectable by optical methods.

20 A "cell condition reporter" is defined herein as an entity that alters its state or characteristics, preferably its optical characteristics, in response to a selected change in the cell's condition. Examples of cell condition reporters include, but are not limited to dyes that are sensitive to transmembrane voltage, intracellular calcium and selected intracellular second messengers, such as cAMP. An exemplary cell condition reporter is the fluorescent dye fluo-3, which fluoresces in response to increased calcium concentrations.

A "receptor" is a macromolecule capable of specifically interacting with a ligand molecule. Receptors may be associated with lipid bilayer membranes, such as the extracellular, golgi or nuclear membranes, and/or be present as free or associated molecules in the cell's cytoplasm. Further, receptors may be either native to the cell biosensor (normally expressed by the cell from which the cell biosensor is derived), or they may be recombinantly expressed.

30 "Recombinantly expressed" refers to proteins, such as receptors, expressed in a host cell as a result of the introduction into the host cell of a nucleic acid containing a region encoding the recombinantly expressed protein. For example, "recombinantly expressed" may refer to receptors expressed in *Xenopus* oocytes from mRNA either isolated from a selected

source, such as a tissue from an organism of choice, or transcribed from a cloned cDNA. "Recombinantly expressed" may also refer to receptors expressed using a eukaryotic expression vector used to transform (either transiently or stably) a host cell line. Prior to transformation, the host cell line may or may not contain and/or express an endogenous version of that
5 receptor.

A "ligand" is a molecule capable of specifically binding to a receptor and altering the receptor's function. Binding of the ligand to the receptor is typically characterized by a high binding affinity, *i.e.*, $K_m > 10^5$. Ligands can act on the receptor directly as agonists or antagonists, or can act indirectly, by affecting the response of the receptor to other agonists
10 and/or antagonists. In either case, the response of the receptor results in a change in the cell's condition (*e.g.* a change in the transmembrane voltage potential or intracellular calcium concentration) which can be detected, for example, by a voltage-recording electrode and/or a cell condition reporter (see above).

A "cell biosensor detection field" is an area of a cell or cells on a substrate from which,
15 at any given time, the state of a cell condition reporter is being recorded, and which, at the same time, is at least partially exposed to effluent from a capillary of a capillary-based separation means. For example, in the case of an optically-detectable cell condition reporter, such a calcium indicator dye, being used with a fluorescence microscope, the cell biosensor detection field is the portion of the image in the microscope that is directed to the
20 photomultiplier tube for signal quantification. Accordingly, a cell biosensor detection field may contain only a portion of a cell (such as a large *Aplysia* neuron), or many cells, such as near-confluent PC12 cells).

II. GENERAL OVERVIEW OF THE INVENTION

25 The present invention provides methods for detecting minute amounts of chemical analytes separated by capillary-based separation means. An important feature of the present invention is that the analyte or analytes to be detected can act as ligands, that is, that they can bind to a specific receptor or receptors. The methods employ cell biosensors expressing specific receptors to serve as ligand analyte detectors. Ligands which bind to a specific
30 receptor result in changes in the cell condition of the cell biosensor, and this change is detected with, for example, a voltage-recording electrode or cell condition reporter, such as a calcium sensitive dye.

III. CAPILLARY-BASED SEPARATION MEANS

Methods of the present invention are particularly advantageous for the detection of minute amounts of ligand analytes suspended in very small volumes (typically picoliter to nanoliter volumes). Accordingly, methods of the present invention are preferably used with
5 separation means that are suitable for separating ligand analytes in such small volumes, such as capillary-based or microcolumn separation means.

A variety of capillary-base separation means exist which are suitable for use with the methods of the present invention, and are detailed below. These methods share the characteristic that they are performed in capillaries, typically fused silica capillaries, having an
10 internal diameter (I.D.) on the order of tens of microns, and an outer diameter (O.D.) on the order of hundreds of microns.

Capillaries are ideally-suited for delivering separated analytes or ligands to cell biosensors, because the inner diameter of a capillary may be selected such that it is similar to the diameter of, for example, a single cell being used as a cell biosensor. Alternatively, the
15 inner diameter of a capillary may be selected such that it is similar to the diameter of a selected group of cells, which together comprise the cell biosensor.

Further, the rigid nature and relatively compact outer diameter of capillaries facilitates the placement of the outlet, or cell end of the capillary (*e.g.* with an "XYZ" positioner, such as a three-axis micromanipulator), at a selected distance from the cell biosensor to achieve the
20 desired degree of dispersion of separated analytes prior to their contact with the cell biosensor. In cases where the diameter of the biosensor is similar to the inner diameter of the capillary, the cell end of the capillary may be placed in close proximity to the biosensor (*e.g.* 20-30 μm). In cases where the inner capillary diameter is smaller than the biosensor, the capillary may be placed further from the biosensor (*e.g.* 30-60 μm), to allow the separated ligands to disperse
25 over an area largely covering the biosensor. The spread of separated ligands may be easily monitored, for example, by the inclusion of a suitable dye in the electrophoresis buffer.

XYZ positioners suitable for positioning the outlet end of capillaries of capillary-based separation means of the present invention include a variety of manipulators available from, for example, Newport Corp., (Irvine, CA) and Narashige, USA, Inc. (Greenvale, NY).
30 Alternatively, cell biosensors may be attached directly at the outlet end of a capillary used in a capillary-based separation means, as is described in detail under "Cell Biosensors", below.

Further, for use with the methods of the present invention, these various separation means preferably employ a cell biosensor compatible buffer in the course of the separation.

A. Cell Biosensor-Compatible Separation Buffers

Methods of the present invention preferably employ biosensor-compatible electrolyte buffers in the capillary-based separation means. Biosensor compatible separation buffers are those buffers that are both effective to serve as separation buffers in selected capillary-based separation means, and to maintain the cell biosensor in a viable state (*i.e.* that do not substantially interfere with the ability (i) of the ligand to bind to a selected receptor, (ii) of the bound receptor to cause a change in the cell condition of the biosensor, and (iii) to detect the change in the cell condition with an electrode or a cell condition reporter).

In cases where intact or substantially intact cells are used, the biosensor-compatible buffer will typically be a physiologically-compatible buffer, such as an extracellular Ringer solution. Such solutions are well known in the art, and may be modified for the maintenance of specific cell types or the conduct of specific experimental manipulations. The composition of an exemplary Ringer solution (capillary electrophoresis Ringer; CE Ringer) suitable for use with capillary electrophoresis-based separation methods is presented in the Materials and Methods section, below.

In addition to being compatible with the selected biosensor, the separation buffers should be effective when employed for separations in the various capillary-based separation means. Such considerations are addressed individually with regard to exemplary capillary-based separation means, below.

20

B. Capillary Electrophoresis

Capillary electrophoresis (CE) is a technique for fractionating chemical species on the basis of differences in the ratios of electrical charge to frictional drag in solution, and is able to separate complex chemical mixtures with high resolution in a few minutes. A number of review articles and books provide an introduction to principles and applications of capillary electrophoresis (Monnig, *et al.*, Grossman and Colburn, 1992, Christensen, *et al.*, Chen, *et al.*, 1988, 1989).

In its simplest and most common embodiment, a capillary electrophoresis system consists of a narrow-bore fused silica capillary (inside diameters range from about 20 μm to about 200 μm , and lengths from about 10 cm to about 100 cm in length) filled with an electrolyte solution. The ends of the capillary are placed in electrolyte-solution reservoirs that contains either a cathode or an anode connected to a high voltage source, typically 20 to 30 kV. Analytes are introduced to the inlet of the capillary, and are detected with a detector near the outlet end. The electrolyte present in the capillary prior to sample introduction is typically the

same or similar to that containing the sample. Separation times are typically in the range of about 1 minute to about 30 minutes.

The simple embodiment described above can be elaborated upon with features such as autosamplers, multiple injection devices, sample/capillary temperature control, programmable
5 power supply, multiple detectors, fraction collection and computer interfacing, among others.

The analytes are typically introduced into the capillary by transferring the inlet (usually from the anode reservoir) to a solution of electrolyte containing the sample for a brief period before the separation field is applied, and applying either an electric field (to induce electroosmotic flow), or a pressure differential, such as positive pressure at the inlet, vacuum
10 at the outlet or gravity, across the capillary to inject the sample. A variety of injection means have been described (Deml, *et al.*, Tsuda, *et al.*, 1987, 1992, Rose, *et al.*, Huang, *et al.*, 1988a), including one suitable for direct sampling of single cells (Chien, *et al.*, Wallingford, *et al.*, 1987a).

Because no "dead volume" is associated with these open capillary separations, the
15 sample volume can be reduced to occupy less than about 1 %, preferably less than about 0.1 % of the capillary volume, provided that the sample contains enough molecules to detect. In fact, in order to achieve a high degree of resolution in capillary electrophoresis, sample volumes should be small in comparison to the total volume of the capillary, typically in the picoliter to nanoliter range (Gordon, *et al.*). For example, a 100 cm capillary with an inside
20 diameter of 75 μm has a volume of about 5 μl . An preferred sample volume for this capillary may range from about 5 nl to about 50 nl.

Despite the use of high separation fields (typically 100 to 1000 V/cm), joule heating in capillary electrophoresis is considerably less than in slab-gel electrophoresis because (i) the high resistance of the narrow capillary channel results in a low current draw (usually 1 to 100
25 μA), and (ii) the high surface area-to-volume ratio of the capillary facilitates heat transfer.

The walls of fused silica capillaries have a negative charge in aqueous solution due to ionization of surface silanol groups. A sheath of mobile counter ions from the electrolyte solution in the capillary accumulates along the negatively-charged capillary surface, and induces electroosmosis (bulk solution flow) when an electric field is applied across the electrolyte-filled
30 capillary. Under typical operating conditions, this sheath of ions is positively charged, and consequently, drags bulk solution from the anode to the cathode. As is pointed out below, however, the inside surface of capillaries may be treated or coated such that the fixed charges are positive and accumulated mobile counterions are negative, thus inducing electroosmosis from the cathode to the anode.

A practical result of electroosmotic flow is that in free-solution capillary electrophoresis, all species -- whether possessing positive, neutral, or negative charge -- can be made to migrate in the same direction past a single detector during a separation. Using the example of "typical" CE, where electroosmotic flow is towards the cathode, a positively-charged sample component emerges early because both the electrophoretic motion of the ion and electroosmotic motion of the electrolyte are in the same direction. If the component is negatively-charged, but its electrophoretic mobility is less than the electroosmotic mobility, than that component also migrated toward the cathode, but at a slower rate.

Many groups have investigated the use of various additives to the capillary electrolyte, and various capillary wall coatings, in part because certain types of analytes are difficult to separate using unmodified, basic capillary electrophoresis techniques. For example, uncharged molecules subjected to capillary electrophoresis do not typically separate from each other, but tend to migrate together as a group. Biomolecules, on the other hand, tend to adhere to capillary walls, causing tailing of their zones and affecting the electroosmotic flow characteristics of the capillary.

Modifications to capillary electrophoresis facilitating the separation of these and other recalcitrant molecules have included the inclusion in the capillary electrolyte of various additives, such as partitioning agents (Terabe, *et al.*, 1984, 1985, Otsuka, *et al.*, Sepaniak, *et al.*, Burton, *et al.*, Balchunas, *et al.*, 1987, 1988, Cohen, A.S., *et al.*, 1987b), macromolecules (Chin, Demorest, *et al.*, Grossman), gels (Shirasaki), modifiers, and sieving matrices (Hjertén, Hjertén, *et al.*, 1985b, 1987a, 1987b), including polyacrylamide gels (Cohen, A.S., *et al.*, 1987a, 1987c, Guttman), as well as coating the walls of the capillaries with agents designed to alter solute-wall interactions (Walbroehl, *et al.*, Fujisawa, *et al.*, Wiktorowicz).

Some of the modifications described in the above paragraph comprise distinct, recognized "modes" of capillary electrophoresis (Li). Different modes of capillary electrophoresis include (i) capillary zone electrophoresis (CZE; Jorgenson, 1984, Altria, *et al.*, Tsuda), (ii) capillary gel electrophoresis (CGE; Hjertén, *et al.*, 1985a, 1985c, 1987, Cohen, *et al.*, 1987a, 1987c), (iii) micellar electrokinetic capillary electrochromatography (MECC; Terabe, *et al.*, 1989, Tsuda, *et al.*, 1982), (iv) capillary electrochromatography (CEC; Knox, Pretorius, Jorgenson, *et al.*, 1985), (v) capillary isoelectric focusing (CIEF; Hjertén, *et al.*, 1985b, 1987, Mazzeo, *et al.*), (vi) capillary isotachopheresis (CITP; Everaerts, *et al.*, Bocek, *et al.*), and (vii) affinity capillary electrophoresis (ACE; Chu, *et al.*, 1992, 1993, Avila, *et al.*, Gomez, *et al.*). It will be understood that all of the above modes fall under the generic definition of capillary electrophoresis.

Considerations for selecting capillary electrophoresis parameters for the separation of specific types of molecules, such as DNA oligonucleotide (Dubrow), peptides (Colburn), proteins (Wiktorowicz, *et al.*) and small molecules (Demarest, *et al.*) have been well documented.

5 The electric field used for separations with capillary electrophoresis is typically maintained at a relatively constant level. As is detailed below, however, certain capillary electrophoresis embodiments may be better served by using pulsed electric fields; specifically, applications which entail electrical (as opposed to optical) measurements of transmembrane voltage. Applications of pulsed electric fields in capillary electrophoresis have been described
10 (Cohen, A.S., *et al.*, 1992).

Detection in capillary electrophoresis is typically performed on-line -- that is, within the separation capillary or just adjacent the outlet, while analytes migrate under the influence of the applied electric field. A plot of the measured detection signal versus separation time produces an "electropherogram", which represents analytes as peaks centered at characteristic
15 migration times. The height (or area) of a peak is preferably related to the concentration of the analyte that produced the peak.

A variety of detection means suitable for use with capillary electrophoresis have been described, including optical detectors based on ultraviolet (UV) absorbance (Lauer, *et al.*, Terabe, *et al.*, 1984, 1985, Otsuka, *et al.*, Walbroehl, *et al.*, 1984, 1986, Fujisawa, *et al.*,
20 Tsuda, Tsuda, *et al.*, 1983a, 1983b) or fluorescence (Jorgenson, *et al.*, 1981a, 1981b, 1983, 1987, Gassman, *et al.*, Gozel, *et al.*, Roach, *et al.*, Green, *et al.*) of the analytes, including circular dichroism (CD) measurements (Christensen, *et al.*), conductivity detectors (Foret, *et al.*, 1986, Everaerts, *et al.*, Huang, *et al.*, 1987, 1988b), electrochemical (amperometric) detectors (Wallingford, *et al.*, 1987b, 1988) mass spectroscopy based detectors (Mack, *et al.*,
25 Whitehouse, *et al.*, Olivares, *et al.*, Smith, *et al.*), Raman-based detectors (Chen, *et al.*, 1988), refractive index detectors (Chen, *et al.*, 1989) and radioisotope based detectors (Berry).

According to methods of the present invention, any of the above detection means may be used in combination with the cell biosensor detection means to enhance the identification of a selected analyte. Such "supplemental" detectors, or supplemental detection means, are
30 preferably those which can detect characteristics of the sample mixture near the outlet end of the capillary without disturbing the mixture. Examples include in-line optical detectors, including UV, fluorescence, CD and refractive index detectors, conductivity detectors and electrochemical detectors. The capillary may include input and output windows near the output

end for use with a supplemental optical detection means, as described, for example, by Johnson, *et al.*

When either the cell biosensor, or the supplemental detection means are adversely affected by electrical noise from the electrophoresis power supply, it may be advantageous to
5 operate the electrophoresis power supply in pulse mode -- that is, turn it on for a selected period of time (*e.g.* for 1 second), and then turn it off for a similar period of time. The noise-sensitive cell biosensor signal may be collected while the power supply is in the off position ("silent"), thereby avoiding electrophoresis-induced electrical noise.

Other capillary-based separation means contemplated for use with methods of the
10 present invention include variations of micro liquid chromatography (micro LC; Berry, *et al.*, 1989), in particular, open tube liquid chromatography (OTLC).

OTLC refers to the method by which a gradient of two solutions is generated for use in the column separation. Conventional methods for generating such a gradient typically employ one of two approaches, which can be characterized as "high pressure" and "low
15 pressure" gradient generation (Berry, *et al.*, 1990). Both of these are generally useful for columns having internal diameters greater than about 1 mm, but are not particularly effective for smaller columns. In contrast, a method and device described by Berry, *et al.*, 1990, allows the generation of gradients for use in columns having internal diameters as small as 5 μm .

Accordingly, OTLC is effective at separating mixtures having volumes comparable to
20 those used with capillary electrophoresis (picoliter to nanoliter range), and may be used as a capillary-based separation means in methods of the present invention. Capillary electrophoresis and OTLC differ in that OTLC typically does not employ an electric field across the capillary. Rather, the sample is pushed through by hydrostatic pressure, typically provided by pressurizing the sample mixture at some point before it enters the inlet end of the column or
25 capillary.

IV. CELL BIOSENSORS

According to methods of the present invention, intact cells and portions thereof
comprise a previously unappreciated class of detectors suitable for use with capillary-based
30 separation means, such as capillary electrophoresis.

As discussed in the "Definitions", a cell biosensor suitable for use with capillary-based separation means of the present invention can be an intact cell, a portion of an intact cell (such as a membrane patch or permeabilized cell), or a group of intact cells. Further, the biosensor

may be in electrical communication with an electrode or electrodes, or may contain a cell condition reporter, such as a calcium-sensitive dye.

Cells comprising the biosensor may be single eukaryotic or prokaryotic cells, groups of such cells, or a confluent layer of such cells. For example, PC12 cells comprise exemplary
5 cell biosensors, as demonstrated in Examples 1, 3, 4 and 5 herein. Further, the cells may be transformed to recombinantly express a selected receptor. In addition, a population of transformed or untransformed cells may be selected using, for example, fluorescence-activated cell sorting (FACS), for those cells expressing high levels of a desired receptor or low levels of an undesired receptor. By selecting a clone or clones having the highest degree of the
10 desired characteristic (*i.e.* clones expressing the highest levels of a desired receptor, or clones expressing the lowest levels of an undesired receptor), growing them up, and repeating the process a selected number of times, a population of cell can be obtained that express a desired receptor at very high or virtually nonexistent levels (depending upon the selection criteria employed). Fluorescence activated cell sorters are available, for example, from Becton
15 Dickinson (Mountain View, CA).

While the invention contemplates providing a separate delivery means to deliver effluent from the outlet of a capillary-based separation means to a cell biosensor, the cell biosensor is preferably placed adjacent the outlet of a capillary-based separation means. This may be accomplished in a number of ways. For example, the cell biosensor may be a cell
20 attached to or growing on the bottom of a saline- or medium-filled recording chamber, and the outlet end of the capillary may be brought such that it is adjacent the cell (*i.e.* $\sim 5\mu\text{m}$ to $\sim 100\mu\text{m}$ above the cell). Such an arrangement is demonstrated in Examples 1 and 2-5 for use with an optically-detectable cell condition reporter. A similar arrangement may be used in conjunction with a voltage recording electrode, such as an extracellular electrode present in the
25 recording chamber, or a voltage clamp, such as whole-cell clamp (Neher and Sakmann). In a similar embodiment, the cell biosensor is a cell, such as a *Xenopus* oocyte or *Aplysia* neuron, placed in a recording chamber with the outlet end of the capillary adjacent the cell as above (*e.g.* Example 2). The cell may contain a cell condition reporter, such as a calcium-sensitive dye, or an electrode, including an intracellular voltage-recording or voltage/patch clamp
30 electrode.

Alternatively, the cell biosensor may be a cell, attached not to the substrate, but to the end of a whole-cell electrode, that is positioned (*e.g.*, with a micromanipulator holding the electrode) at the outlet end of the capillary. Isolated patches of the type formed during patch clamp recording (Sakmann and Neher) are also suitable for use as biosensors. Patch electrodes

having isolated membrane patches may be positioned, for example, using a micromanipulator, adjacent the capillary outlet as described above.

The cell biosensor may be attached at the outlet end of the capillary of a capillary-based separation means either directly or through a substrate. For example, the outlet end of the capillary may be touched to a cell in a culture dish, causing the cell to detach from the culture dish and attach to the outlet tip of the capillary. The attached cell is suitable for use as a biosensor if part of the capillary eluent comes in contact with the cell. In a related embodiment of the invention, cells are cultured directly in the outlet tip of the capillary. This may be accomplished prior to the initiation of a separation run by "plating" cells in the portion of the capillary at the outlet end using, for example, suction to draw a suspension of cells into the outlet end portion of the capillary, and allowing the cells to adhere to the inside wall of the capillary. The portion of the capillary in which cells are to be plated may be coated prior to the plating of the cells with a substance that supports the attachment and/or growth of cells (*e.g.*, poly-lysine).

A cell biosensor may also be attached to the outlet end of a capillary used in a capillary-based separation means via a solid support on which the cell is growing. For example, one embodiment of the present invention provides a removable solid support on which cells can be grown, and which can be attached at the outlet end of a capillary used in a capillary-based separation means. The support may consist of, for example, a short glass or plastic tube having an inner diameter that is slightly larger than the outer diameter of the capillary at the outlet end. Cells can be grown inside the tube using standard tissue culture techniques. When the cells have grown to possess properties rendering them suitable for use as cell biosensors, the tube may be slipped part way over the outlet end of the capillary, thus providing a biosensor for identifying a selected ligand in a mixture of ligands separated using a capillary-based separation means. The portion of the tube extending past the outlet end of the capillary may include an angle (*e.g.*, a right angle) to facilitate contact of the stream of eluent with cells located in the tube at the outer portion of the angle.

It will be understood that the outer diameter of the capillary at the outlet may be reduced, for example, by exposure to hydrofluoric acid, to accommodate a cell culture tube of a smaller inner diameter than the normal outer diameter of the capillary.

Another example of a removable solid support is a substantially planar support that includes an attachment means to attach the support at the outlet end of the capillary. The attachment means may be a ring, having an inner diameter as above, that can be slipped over the outlet end of the capillary. With the attachment means engaged with the outlet end of the

capillary, the planar support may be positioned at a selected distance from the capillary outlet such that the surface of the support containing the cells is substantially perpendicular to the stream of eluent from the capillary outlet. Alternatively, the support surface containing the cells may be placed at an angle other than perpendicular to the eluent stream, such that the stream is only deflected as it passes over the cells.

Certain embodiments in which the cell biosensor is attached to the capillary may be amenable to automation. For example, an automated device can contain a supply of tubes containing cells, as described above, and a mechanical element, such as a robotic arm, can place fresh tubes over the outlet end of the capillary as desired. Alternatively, the outlet end of a capillary can be fitted with a rotatable motorized shaft oriented substantially parallel to the capillary and approximately coextensive with the outlet tip of the capillary. A variation of the planar substrate with attachment means, described above, can be fashioned to comprise, for example, a circular planar substrate containing cells oriented about a central axis. Such an assembly can be attached to the motorized shaft such that the substrate is perpendicular to the capillary, and that eluent from the capillary flows onto the cells in a selected region of the substrate. By rotating the motor, a different portion of the substrate, containing fresh cells, is exposed to the capillary eluent. The rotation may be set up to be interrupted, allowing recording from a selected region for a selected period of time, or continuous.

In any embodiment of the invention that provides a means of moving the capillary outlet relative to a substrate containing cell biosensors, and in which it is desirable to obtain quantitative information on the amount of ligand in the separated capillary effluent, confluent or near-confluent layers of cells, due to their relative uniformity, may constitute particularly effective biosensors. As is detailed below, receptors typically desensitize following repeated applications of agonist. This desensitization increases the difficulty of obtaining quantitative information from cell biosensors, since quantitating responses typically requires generating a standard curve of responses to a range of agonist concentrations.

One method of avoiding the desensitization problem is to record each response with a fresh biosensor. For this to be effective, however, the different biosensors must be relatively homogeneous in their response characteristics (*i.e.* if optical detection methods are being used (see below) without ratiometric imaging, each cell biosensor detection field should have approximately the same detectable cellular response to a given amount of ligand. A confluent or near-confluent layer of cells is advantageous in this regard, because the cell biosensor constitutes the cells contained in an area that is exposed to separated ligands and that is within the cell biosensor detection field of a detection device. By moving the outlet of the capillary

and the detector to a different region of the confluent cell layer, one may obtain a fresh biosensor (one whose receptors have not desensitized) with similar response characteristics (if the cells are relatively homogeneous) to the original.

Any scanning technique in which the outlet end of the capillary is moved with respect
5 to the cell biosensor, or *vice versa*, may be automated. For example, an approach similar to that discussed above for cell biosensors attached to the capillary may be employed with cell biosensors present in a recording chamber. The "XY" controls of the stage holding the recording chamber can be interfaced with precision motor drives (available, for example, from Newport Instruments (Irvine, CA), which can be directed to move the chamber to selected
10 positions with respect to the capillary outlet (it is understood, of course, that the motor drives can be incorporated to control the movement of the capillary as well).

As discussed above, the movement can be rapid, interrupted movement, or smooth, continuous movement. Provided that a substrate containing a confluent or near-confluent layer of cells is available, the continuous scanning technique affords a significant advantage regarding
15 receptor desensitization. That is, the cell biosensor detection field can be moved at a rate that is faster than the predominant time constant of receptor desensitization. In this way, the detectable cell biosensor receptors do not desensitize, since cells which had been exposed to a desensitization-inducing ligand long enough to experience significant desensitization are no longer contributing to the biosensor signal.

20 As receptors recover from desensitized states and return to the states they were in prior to application of ligand, they may again be used as cell biosensors. Based on the knowledge of the rates of receptor desensitization and recovery from desensitization, which may be readily determined by appropriately-timed applications of agonists (Hille), it is possible to construct a substrate that has a large enough area to enable sustained cell biosensor recording for the
25 lifetime of the cell biosensor, without encountering appreciable difficulty due to receptor desensitization.

The recording dish may be perfused, either continuously or periodically, with fresh recording solution, for example, in cases when the volume of the recording solution is such that a concentration of ligand high enough to interfere with cell biosensor responses to capillary
30 effluent may build up over the lifetime of the separation process.

It will be understood that solid supports and substrates referred to above may be coated with any of a variety of agents that promote the adhesion and/or growth of cells plated on the substrate. Such agents include coatings that alter surface charge, such as poly-lysine and poly-

ornithine, various matrixes designed to support cell growth, and selected extracellular matrix components, including collagen, fibronectin and gelatin.

V. RESPONSE DETECTION METHODS

5 The binding of a selected ligand to a receptor in or on a cell biosensor may be detected by any of several methods that report the condition of the cell biosensor. Two exemplary methods of detecting the condition of a cell are (i) substances, or cell condition reporters, that alter their characteristics, preferably optical characteristics, in response to selected specific changes in a cell's condition (such as increase in intracellular calcium), and (ii) electrodes
10 capable of detecting changes in the transmembrane potential of the cell.

A. Cell Condition Reporter Detection

Many types of cell condition reporters are available. They can be grouped according to the type of cellular event to which they are sensitive, or according to the method by which
15 they are detected. According to methods of the present invention, preferred methods for detecting the state of cell condition reporters are optical. Cell condition reporters whose state may be detected by optical methods may be referred to herein as optically-detectable cell condition reporters.

Optical detection may comprise assaying changes in absorbance or detection of
20 luminescent or fluorescent signals. Fluorescence tends to be more sensitive than absorbance, because fluorescence is detected as an increment above a low background rather than a small decrement from the full intensity of the incident beam (Tsien, 1992). Fluorescence is also advantageous over luminescence in cases where the amount of probe is limited, because each fluorophore can emit many thousands of photons (energized by the excitation beam) as opposed
25 to the maximum of one photon emitted by a luminescent molecule. Luminescence may be advantageous, however, in cases where background fluorescence is high.

In part due to the advantages of fluorescence outlined above, most optically-detectable cell condition reporters currently available are fluorescent molecules that alter their fluorescence as a result of binding to a particular cell constituent or as a result of a change in the cell's pH
30 or transmembrane voltage potential. They are discussed below in relation to the cellular event to which they are sensitive.

Many of these optically-detectable cell-condition reporters, or dyes, are amenable to ratio imaging, or ratiometric quantitative determination of the signal (Bright, *et al.*, 1987, 1989, Taylor, D.L., and Wang, Tanasugarn, *et al.*). In ratio imaging, the optical

characteristics of the dye are measured at two different wavelengths. The wavelengths are selected such that the optical property being measured (*e.g.* fluorescence) is essentially independent of the cellular condition to which the dye is sensitive (*e.g.* calcium concentration) at the first wavelength, but is maximally-sensitive to that condition at the second wavelength.

5 To obtain a measurement of the cellular condition, the amplitude of the optical signal at the second wavelength is divided by the amplitude of the signal at the first wavelength. This ratiometric measurement normalizes for extraneous factors such as the optical path length through the cells, the fraction of cellular volume accessible to the dye, and the fraction of the detection field occupied by active cell biosensors, and provides a more reliable estimate of the
10 cellular condition.

Optically-detectable cell condition reporters have been developed for detecting a variety of conditions, including transmembrane voltage, and levels of intracellular calcium, chloride, magnesium, sodium, pH, cAMP and activated calmodulin (Slavik, Tsien, 1989a).

15 1. Calcium-Sensitive Dyes

Among the first classes of molecular probes to be developed were fluorescent indicator dyes sensitive to calcium. The dye quin-2 was one of the first to exhibit good selectivity for calcium over magnesium and result in usable fluorescence (Tsien, 1980). Because the dye molecule was charged at neutral pH, however, introducing it into cells required micro-injection.
20 This imposed certain limitations on the types of experiments possible. To overcome this, uncharged ester, typically acetomethyl (AM) ester, forms of the dyes were synthesized (Tsien 1981). The uncharged esterified forms readily diffuse through the plasma membrane and enter the cell, where they are cleaved by endogenous esterases to liberate active, membrane-impermeant dye.

25 Determinations of $[Ca^{2+}]_i$ in single cells were greatly facilitated by the synthesis of fura-2 and indo-1 (Grynkiewicz, *et al.*). Both dyes have bright-enough fluorescence to image single cells and introduce only a limited amount of Ca^{2+} buffering to the cell. In addition, these dyes are amenable to ratio imaging (see above), and can thus be used to estimate absolute calcium concentrations in the cell. A more recent addition is the dye fluo-3 (Kao, *et al.*),
30 which was used (both in native and AM-ester forms) in experiments detailed herein in Examples 1, 3, 4 and 5.

Dyes sensitive to calcium are effective as cell condition reporters for selected ligands which, by binding to a specific receptor, change (typically increase) the calcium concentration in a cell. Examples of receptors effective to alter intracellular calcium are presented below.

For instance, experiments detailed herein demonstrate the elevation of intracellular calcium, as detected by the dye fluo-3, in mammalian cells expressing bradykinin or acetylcholine receptors (Examples 1, 3,4,5).

5 2. pH-sensitive Dyes

A variety of pH-sensitive indicators have been synthesized (reviewed in Tanasugarn, *et al.*, and Tsien, 1989b). Modifications of an existing dye resulted in "BCECF" (Rink, *et al.*), an exemplary pH indicator which is amenable to ratio imaging. The dye is sensitive to pH in the range of pH ~5.6 to pH ~8.0 at an excitation wavelength of 500 nm, but is
10 relatively insensitive to pH at 450 nm.

3. Dyes Sensitive to Other Inorganic Molecules

Detection of intracellular sodium is possible using the fluorescent indicator molecule "SBFI" (Minta, *et al.*). While the dye has certain limitations, it is suitable for detection of
15 increases in intracellular sodium of cell biosensors.

Detector dyes are also available for chloride and magnesium (Tsien, 1989b).

4. Voltage-sensitive Dyes

Many dyes which insert into the plasma membrane and alter their fluorescence in
20 response to the transmembrane voltage potential (voltage-sensitive dyes) are currently available (Cohen, Ross, *et al.*, Gupta, *et al.*). The most effective of these were identified by synthesizing and testing more than a thousand organic dyes. An exemplary voltage-sensitive dye is di-4-ANEPPS (Loew, *et al.*). This dye displays an increase in fluorescence combined with a redshift of the excitation spectrum upon hyperpolarization. The signal-to-noise of the
25 potentiometric fluorescence response is among the best recorded for any dye. Further, the dye is amenable to ratio imaging, shows no appreciable signal deterioration over extended recording periods and has an excellent signal-to-noise ratio.

Voltage-sensitive dyes, such as di-4-ANEPPS, may be used as cell condition reporters in cases where the binding of a selected ligand to a receptor results in a change in the
30 transmembrane voltage of a cell or patch. Examples of receptors having this effect are discussed below. In particular, experiments performed in support of the present invention demonstrate that the ligand serotonin is effective to produce an inward current in an oocyte expressing a serotonin receptor (Example 2).

5. Second Messenger Dyes

In addition to the optically-detectable cell condition reporters described above for simple spherical inorganic ions, molecular probes have been developed that are sensitive to the concentration of organic "second messenger" molecules, such as cyclic adenosine monophosphate (cAMP) and calmodulin.

The indicator for cAMP is based on a cAMP-dependent protein kinase (Taylor, S.S., *et al.*, 1990). The catalytic (C) and regulatory (R) subunits are each labelled with a different fluorescent dye, such as rhodamine and fluorescein, capable of fluorescence resonance energy transfer in the holoenzyme complex R_2C_2 . When cAMP molecules bind to the R subunits, the C subunits dissociate, thereby eliminating energy transfer. The change in shape of the fluorescence emission spectrum allows cAMP concentration to be visualized in a living cell injected with the labelled holoenzyme (Adams, *et al.*) by employing ratio imaging (above). Accordingly, this indicator is a cell condition reporter sensitive to ligands which alter the level of cAMP in the cell.

Hahn, *et al.*, (1990) have linked a tetramethinemercocyanine fluorophore to the calcium-binding protein calmodulin. The resulting conjugate, MeroCaM, has a reversible calcium-induced 3.4-fold increase in excitation ratio (608/532 nm), apparently due to the binding of calcium to the high affinity sites on the calmodulin molecule. MeroCaM has been used to image calmodulin activation in Swiss 3T3 fibroblasts *in vivo* (Hahn, *et al.*, 1992).

6. Optical Detectors for use with Optically-Detectable Cell Condition Reporters

A variety of methods may be used to optically monitor signals, such as fluorescence signals, in cell biosensors. An exemplary apparatus for recording optical signals from cell biosensors in response to effluent from a capillary-based separation means is illustrated in Figures 1A and 1B. The device includes a capillary 2 for the separation of a mixture of ligands. A mixture of ligands is introduced into the inlet end 4 of the capillary, for example, by placing the inlet end in a vial 6 containing the mixture. The other end 8 (outlet or cell end) of the capillary is placed in proximity to a cell biosensor, such as a eukaryotic cell 10 on a glass coverslip 12 forming the bottom of a recording chamber 14. The cell end 8 can be positioned at a selected location by means of an XYZ positioner 16. An exemplary means of achieving positioning is shown in the diagram. A portion of the capillary proximal to the cell end is threaded through a hollow needle (such as a syringe needle) 18 and is glued at the needle entrance and exit points to stabilize the position of the outlet. The needle, in turn, is

fastened to the XYZ positioner. The needle may be bent into a conformation to facilitate placement of the cell end of the capillary adjacent the biosensor.

A power supply is indicated at 20, and electrophoresis electrodes at 22 and 24. Separated analytes 26 are delivered to the cell biosensor 10, which had been loaded with a dye
5 (see below) responsive to cellular changes anticipated as a result of exposure of the cell to a selected ligand analyte. The response of the dye is detected by an optical detector via, for example, a microscope objective 28 placed under the coverslip.

The optical detector may be an inverted fluorescence microscope, such as a Zeiss AxioVert or IM35 (Carl Zeiss, Inc., Thornwood, NY) or Nikon 300 or Diaphot-TMD-EF
10 (Nikon Inc., Melville, NY). Techniques for optically monitoring the state of cell condition reporters and for analyzing resultant information (*e.g.* images) are known in the art (*e.g.* Taylor, D.L., and Wang, Taylor, D.L., *et al.*, 1986, 1992, Herman and Jacobson, Conn, 1990, deWeer and Salzberg, Lakowicz, Slavik, Duchen, Harootunian, 1988, 1991a, 1991b, Poenie). One method for recording a fluorescent signal using a fluorescence microscope (a
15 Nikon Diaphot-TMD-EF) is detailed in Example 1.

Figure 1C shows a view of a cell end of a 25 μm I.D. capillary positioned above a single cell as imaged with an objective such as shown at 28 in Figure 1A.

It will be understood, however, that the use of a microscope is not necessarily required for optical detection of the state of cell condition reporters. For example, in applications where
20 it is not necessary to obtain an image of the cell biosensor, the optical detector may simply be a light pipe (such as a fiber optic cable) in combination with appropriate optical filters, directed to a photomultiplier tube. Excitation light for fluorescence imaging in such situations may be provided by an appropriately-filtered high-intensity light source, directed at the sample using, for example, a fiber optic cable.

25 Alternatively, the cell biosensor may be placed in a spectrophotometer, and the absorbance of the cell condition reporter monitored as eluent from a capillary-based separation means, containing separated ligands, is washed over the cell biosensor.

Use of an exemplary optically-detectable cell condition reporter in conjunction with the device described in relation to Figures 1A and 1B is demonstrated in Example 1. Detailed in
30 the example is a separation of acetylcholine (ACh), bradykinin (BK) and adenosine triphosphate (ATP), and subsequent detection of these ligands by a PC12 cell-based cell biosensor using a calcium-sensitive dye as the cell condition reporter.

The results, shown in Figure 2, demonstrate the ability of a separation-detection system employing a cell biosensor to detect and identify selected ligands in a mixture of ligands

separated using a capillary-based separation means. Identification is confirmed by running standards containing only the selected ligand.

Detection of components in complex biological mixtures is a more stringent test of analyte identification capacity than is identification of standard solutions. An exemplary
5 complex biological mixture is a lysate of PC12 cells containing endogenously-produced acetylcholine. An experiment performed according to methods of the present invention utilizing PC12 lysate as a mixture of ligands is presented in Example 1. PC12 cells having natively-produced ACh receptors (AChRs) are used as the biosensor for acetylcholine.

The results, shown in Figure 3, demonstrate the ability of the separation/detection
10 system described herein to separate and identify a selected ligand (acetylcholine) in a complex mixture of ligands (PC12 lysate). The lysate peak likely corresponds to an acetylcholine content in the low femtomole range (Greene, *et al.*, 1977), illustrating the high sensitivity of the methods described herein. Accordingly, two advantages of the present invention demonstrated by the above experiments are (i) ability to identify a selected ligand in a highly
15 complex mixture of ligands, and (ii) the ability to identify a selected ligand that is present in very low concentrations (*e.g.*, in the femptomolar range).

Of the species examined in experiments detailed herein, the highest sensitivity is achieved for BK. To investigate the detection sensitivity and reproducibility for this species, five capillary electrophoresis runs of BK are performed at each of three concentrations, using
20 an individual cell as the cell biosensor. A different PC12 cell is selected as the cell biosensor for each run to avoid cell biosensor desensitization, and care is taken to set the capillary outlet at the same distance ($\sim 40 \mu\text{m}$) from the cell for each run. At $10 \mu\text{M}$ and 100 nM concentrations, 4/5 and 5/5 cells, respectively, respond to BK after electrophoresis. Higher sensitivities may be obtained by differentiating the cells (Bush, *et al.*) and/or selecting clones
25 expressing high amounts of the BK receptor (*e.g.* using fluorescence-activated cell sorting as described above).

In general, detection limits for different ligands may range from more than picomoles to a few molecules (Mori, *et al.*). Factors that affect the detection signal include the ligand-receptor dissociation constant, the number of receptors exposed to ligand, the
30 amplification pathways accessed after binding, the baseline variability in the quantity being measured, and frequently, the chemoreception history of the cell. Cellular response mechanisms can be manipulated to improve sensitivity and reproducibility. Differentiation of PC12 cells, for example, has been shown to strongly potentiate the calcium response to

bradykinin (Bush, *et al.*), and receptor mutagenesis has the potential to greatly reduce desensitization (Jackson).

Example 3 details another application of the above system, and further demonstrates the capacity to scan the outlet of the capillary-based separation means relative to the recording chamber to employ fresh biosensors. The results, shown in Figures 6A, 6B, 6C and 6D demonstrate that effects of receptor desensitization may be minimized by providing fresh biosensors for consecutive separations. Pulses of bradykinin are separated and applied to the cell biosensor. The responses are evicent as peaks, or "spikes". The results show that the scanning can occur by moving the capillary outlet while maintaining the dish containing the cell biosensors stationary (Figs. 6C and 6D) or by translating the substrate containing the biosensors with respect to a stationary capillary (Fig. 6B). The breaks in the records reflect the interruption due to scanning.

The results also provide information as to the time course of receptor desensitization (the rate at which peaks decrease in response to applications of approximately the same amount of ligand). Using this information, an automatic system may be designed that continually scans a substrate containing near-confluent cell biosensors at a rate fast enough that effects of desensitization are not appreciable (see above). In order to improve the reproducibility of responses from different biosensors, a confluent or semi-confluent layer of cells may be used, as discussed above.

Example 4 illustrates selective blocking of cell biosensor responses to electrophoresed ligands by specific receptor antagonists. The data, shown in Figures 7, 8A and 8B, show selective inhibition of cell biosensor responses to bradykinin by bradykinin receptor antagonist HOE 140 (Fig. 7) present in the recording solution, and selective inhibition of cell biosensor responses to acetylcholine by acetylcholine receptor antagonists atropine and α -bungarotoxin present in the recording solution (Figs. 8A and 8B).

These results illustrate an important aspect of the present invention -- that is, the ability to use specific receptor antagonists to confirm the identity of the receptor giving rise to the cell condition reporter signal. As is discussed below, many receptors, upon activation, result in a similar signal (such as a rise in intracellular free calcium). Since most cells (and accordingly, cell biosensors) express a variety of different receptors, a response to a selected ligand may not be interpretable, particularly if the identity of the selected ligand is not known. In contrast to the generality of cellular responses to receptor activation, there exist a wide variety of very specific receptor antagonists, which are often able to discriminate closely-related receptor subtypes (*e.g.*, Hille). Accordingly, it may be desirable to perform a series of separations on

the same sample, and include various specific receptor antagonists in some of the runs. As is demonstrated in Example 4 and Figures 7, 8A and 8B, such an approach is effective at confirming the identity of receptors giving rise to the signal recorded from the cell condition reporter.

5 The receptor-specific antagonists may be present in the recording solution, as shown in Example 4, or they may be applied locally to the cell biosensor in the biosensor detection field. For example, a second capillary containing the antagonist can be positioned to apply antagonist eluent (*e.g.* by pressure ejection) onto the cell biosensor detection field during a separation run. The concentration of the antagonist can be adjusted such that it is effective to
10 antagonize the receptors in the cell biosensor detection field, but to fall off to levels which do not substantially interfere with receptors outside of the detection field. By applying a recording chamber perfusion as described above, a build-up of antagonist concentration can be avoided. If a build-up of antagonist does occur, the chamber may be perfused with fresh solution as described.

15 It will be understood that more than one source of antagonist (preferably different antagonists) may be directed at the biosensor detection field. These sources may be independently controlled, for example, using pressure ejection, to apply different antagonist at selected times.

 Example 5 shows that methods of the present invention may be used to separate and
20 resolve distinct ligands, such as bradykinin and Lys-bradykinin, having similar chemical characteristics. The data are shown in Figure 9. Lys-bradykinin and bradykinin are identified as two well-resolved peaks, even though they differ by only one amino acid (American Peptide Company, Inc., Sunnyvale, CA; 1994-1995 catalog).

 These results further demonstrate that the biological activity of closely-related
25 compounds can be assayed using a capillary-based separation means in conjunction with a cell biosensor, such as described herein. This application may be particularly useful in assaying breakdown products or proteolytic fragments of a parent compound. For example, if the parent compound is a pro-peptide that gets digested down to an active species, the appearance of the active species may be monitored using methods of the present invention, by employing a
30 receptor for the active form of the peptide. In a related application, the biological activity of breakdown products of a drug or therapeutic agent may be monitored.

 Several observations regarding use of the system shown in Figures 1A and 1B may be useful. More reproducible results seem to be obtained when the capillary outlet is positioned at least about 20 μm away from the cells (reducing the likelihood of damage to the cells by the

electrophoresis field). Further, it is desirable to prevent unnecessary movement of the capillary with respect to the cell biosensor when the cell biosensor consists of a single cell or only a few cells and the capillary diameter is similar to the cell's diameter. Standard vibration-control precautions, such as using a vibration isolation table (Newport Corp., Irvine, CA), can alleviate these potential problems.

B. Direct Transmembrane Voltage Detection

Methods of the present invention may also employ direct transmembrane voltage detection with extracellular or intracellular microelectrodes. The activation of many receptors, particularly those directly linked to ion channels, results in a change in the transmembrane voltage of the cell. Such a change may be detected, for example, with the use of voltage-sensitive dyes (as detailed above), or using voltage-recording electrodes. Three general modes of voltage recording using electrodes are (i) extracellular recording, where an electrode or electrodes are placed in the vicinity of the cell, but do not penetrate the plasma membrane, (ii) intracellular recording, where the electrode is in electrical communication with the interior of the cell, and (iii) patch clamp recording. Intracellular and patch recording are capable of measuring an intracellular potential with respect to the bath, and detecting changes to that value over time, while extracellular recording is typically useful only for detecting changes in the membrane potential. With intracellular and patch recording, it is also possible to "voltage-clamp" the cell membrane to a desired voltage by injecting current, either through the voltage recording electrode or through a separate current-passing electrode. In voltage-clamp mode, the recorded signal is typically the amount of current passed to maintain the cell at the desired potential as a function of time.

Extracellular electrodes function by detecting a change in the electric field in the vicinity of an electrically active cell. They are not particularly effective at quantitating the amplitude of a transmembrane voltage change, but can qualitatively detect that a voltage change has occurred. Extracellular recording electrodes may be either built in to the substrate on which the cells are grown (Pine, Meister, *et al.*), or placed adjacent the cell biosensor using, for example, a micromanipulator. A variety of extracellular recording techniques have been described which may be employed in methods of the present invention (*e.g.*, Pine, Forda, *et al.*, Gross, *et al.*, Cohen, *et al.*, Meister, *et al.*).

Intracellular recording typically utilizes a sharp glass microelectrode filled with a high salt electrolyte solution, typically ~3M KCl. A metal electrode, typically silver with a coating of silver chloride, is placed in electrical contact with the electrolyte solution and connected to

a voltage recorder, or voltage clamp. If a voltage clamp is used, the output is typically directed to a chart recorder or a computer for later analysis.

Intracellular recording and/or voltage clamp may be used, for example, with *Xenopus* oocytes, as detailed in Example 2 herein. Oocytes are advantageous because they are capable
5 of expressing injected mRNA encoding specific receptors. Methods for expressing ion channels and receptors in *Xenopus* oocytes, and voltage/current recording from oocytes are well known (e.g. Leonard and Snutch; Wang, *et al.*; see below).

Patch recording, typically conducted in the voltage-clamp mode, exploits the observation that under appropriate conditions, it is possible to obtain an electrically-tight seal
10 between the tip of a blunt fire-polished pipet filled with physiological saline solution and the plasma membrane of a cell (Hamill, *et al.*; Sakmann and Neher). Such seals introduce a resistance between the interior of the pipet and the bath ranging from about 1 GOhm to over 100 GOhms. When a high-resistance seal is obtained, it is often possible to visualize the activity of single ion channels opening and closing in the membrane beneath the patch pipet.
15 This mode of recording is referred to as "cell-attached".

If a brief pulse of suction is applied to the patch pipet, it is possible to rupture the membrane beneath the pipet and establish electrical communication with the interior of the cell (whole-cell mode). It is also possible to isolate a patch of membrane by pulling the patch pipet off the cell. If the pipet is pulled off in cell-attached mode, the patch is usually an "inside-out"
20 patch, because the cytoplasmic face of the membrane patch is exposed to the extracellular solution bathing the cell. If the pipet is pulled off in whole-cell mode, the cell membrane typically reseals and forms a patch in an outside-out configuration (the extracellular aspect of the patch membrane is facing the bath solution).

Whole-cell mode is similar to intracellular recording or voltage clamp, but it allows
25 control of the cell's intracellular solution. The patch modes (cell-attached, inside-out and outside-out) enable the recording of currents through single ion channel molecules. In all modes, electrical communication between the pipet and the patch clamp itself is via an electrode immersed in the physiological electrolyte present in the patch pipet. As is the case with voltage recording, the electrode is typically a silver wire coated with silver chloride.

30 The methods outlined above are well known in the art (e.g., Smith and Gage, Conn, 1991a, Wallis, Hille). Equipment and instrumentation for acquiring and analyzing data using voltage recording, voltage clamping, patch clamping, oocyte injection, oocyte recording, etc. is widely commercially-available. For example, pipet pullers maybe obtained from Narashige, USA, Inc. (Greenvale, NY) or Zeitz-Instrumente Vertriebs (Augsburg, Germany); manipulators

may be obtained from Narashige, USA, or Newport Corp. (Irvine, CA); pressure injectors may be obtained from Dagan Corporation (Minneapolis, MN) or Fisher Scientific (Pittsburgh, PA); recording chambers may be obtained from Dagan Corp.; and patch clamps, voltage clamps, computer interfaces and digital tape recorders may be obtained from Dagan Corp. or Axon
5 Instruments (Foster City, CA).

Figure 4 shows a schematic of an exemplary device useful for practicing the present invention. This device includes a capillary 2 for the separation of a mixture of ligands. A mixture of ligands is introduced into the capillary inlet as above. The cell end 4 of the capillary is placed in proximity to a cell biosensor, such as an oocyte 6.

10 The device further includes an electrophoresis reservoir 8 around the capillary approximately 10 cm upstream from the cell end, which is sealed at its bottom end 10 to prevent leakage of electrophoresis buffer into the solution bathing the cell biosensor. The reservoir contains an electrophoresis buffer, such as CE Ringer, in electrical communication with the electrophoresis ground 12. The capillary has a fracture 14 enabling electrical
15 communication between the interior of the capillary and the electrophoresis buffer in the reservoir. The fracture serves to ground the capillary upstream from the biosensor to reduce electrical interference in voltage-clamp recording. The portion of the capillary above the fracture is immobilized to a splint, for example, glued 16 to a side of the reservoir containing the electrophoresis buffer.

20 The transmembrane voltage and/or current of the cell biosensor is measured using, for example, a two-electrode voltage clamp, which includes a current-passing electrode 18, a voltage-recording electrode 20 and a bath ground 22 in electrical communication with the solution 24 bathing the cell biosensor.

The cell end of the capillary can be positioned at a selected location with respect to the
25 cell biosensor by means of an XYZ positioner attached to, for example, the electrophoresis reservoir 8, essentially as described above.

The fracture 14 in the capillary can be fashioned as described by Linhares and Kissinger. In this method, the capillary is glued to a 2 cm × 1 cm microscope slide with epoxy glue (*e.g.* SIG Mfg. Co., Montezuma, IA) such that an exposed portion, immobilized
30 at both ends, rests approximately 1 mm above the surface of the slide. A diamond capillary glass cutter is used to make a small scratch on the top of the exposed portion, and a pointed stylist is gently pushed between the slide and the capillary to produce a fracture. The fracture assembly is placed, for example, in a 5 ml Teflon vial with a hole drilled in the bottom. The outlet end of the capillary is pushed through a rubber septum that plugs the hole.

Several approaches may be taken to reduce electrical noise during recording. If it is desired to obtain an uninterrupted record of cell biosensor electrical activity, proper grounding of all components near the recording chamber is necessary. In particular, the portion of the capillary between the fracture and the outlet (cell end) may be coated with an electrically-
5 conductive material and grounded. Methods for electroplating glass or silica with electrically-conductive coatings may be found, for example, in Bard.

If regular interruptions in the electrical recording are permissible, methods of the present invention may be practiced using a pulsed electrophoresis power supply (Cohen, M.L., *et al.*, 1992). The acquisition computer may be programmed to sample voltage or current
10 records only during the period that the electrophoresis power supply is off. This may decrease the electrical noise in the system by about an order of magnitude, and may allow the recording of ion currents through single ion channels.

Such a biosensor system can provide a nearly unprecedented level of sensitivity -- for example, since an inotropic receptor typically requires only a few agonist molecules for
15 opening, the method may be applicable for the detection of samples containing only minute amounts of a selected ligand, perhaps as little as a few hundred molecules.

Example 2 details an application of the recording system described in Figure 4 to record responses of *Xenopus* oocytes to serotonin delivered using a capillary-based separation means. The electropherograms are shown in Figure 5. Upward deflections indicate inward
20 current. The current is likely due to the activation of oocyte-endogenous calcium-activated chloride channels, stimulated by a rise in intracellular free calcium due to the binding of serotonin to the recombinantly expressed serotonin receptor.

The results show that electrodes may be effectively employed with cell biosensors to detect a selected ligand in a mixture of ligands separated using a capillary-based separation
25 means. The result also demonstrate that the signal detected from a cell condition reprotor or electrode may be due to a secondary response to ligand binding to a specific receptor. In particular, a variety of ion channels are now known to respond to intracellular second messengers activated by the binding of an agonist to a receptor (Hille).

30 VI. RECEPTORS AND LIGANDS

A. Receptors

Nearly all cells possess on their surface various receptors specific for appropriate agonists. Upon binding of an appropriate agonist, the receptor alters its conformation and initiates a cellular response. In the case of inotropic receptors, such as the nicotinic

acetylcholine receptor or the *N*-methyl *D*-aspartate (NMDA) receptor, the receptor is itself an ion channel, and binding of the appropriate ligand opens the ion channel, typically on the order of milliseconds. Opening of the channel results in an increased membrane conductance for those ions which can pass through the receptor, which typically results in a change in the
5 membrane potential. The membrane potential change can be detected with voltage-sensitive electrodes, or voltage-sensitive dyes (as described above). If the membrane is clamped to a selected voltage, the opening of the channel typically results in an ionic current flowing through the channel, which can be measured by the voltage clamp apparatus.

In addition to detecting voltage changes, it may be possible to directly detect the influx
10 or efflux of certain ions through open ion channels, using fluorescent dyes sensitive to the concentrations of those ions (described above). For example, many ion channels and inotropic receptors are at least partially permeable to calcium. Since the electrochemical driving force for calcium is typically inward at most physiological potentials, the opening of a channel permeable to calcium is accompanied by an increase in the intracellular calcium concentration
15 in the vicinity of the ion channel. This increase may be detected using, for example, a calcium-sensitive dye, such as fluo-3.

In the case of metabotropic receptors, binding of the appropriate agonist to the receptor may cause a conformational change that typically initiates one of several well-characterized biochemical signaling cascades, many of which result from an interaction of the activated
20 receptor with a "G-protein" (Stryer, Teichberg and Habenicht, Kito). The specific cascade initiated depends, of course, on the receptor activated. The intermediates in an activated cascade may involve calcium and cyclic nucleotides, such as cAMP and cGMP.

For example, activation of the inositol triphosphate (IP₃) pathway typically results in the release of calcium from intracellular stores, and leads to a transient increase in free
25 intracellular calcium concentration (Hille). Accordingly, activation of receptors which exert their effect through the IP₃ pathway is expected to result in an increase in intracellular calcium, which can be detected using, for example, one of the calcium indicator dyes described above. In an analogous manner, activation of receptors which exert their effects through cAMP may be detected using, for example, the cAMP indicator system described above.

30 One of the advantages of the methods of the present invention is the sensitivity afforded by the amplification inherent in many metabotropic receptors. Because a single receptor activation event can result in the liberation/production of thousands of second messenger molecules, the present methods may be used to detect minute amounts of a selected ligand.

It will be understood that because receptors were often named on the basis of what was considered to be the natural agonist, and before the molecular structure of the receptor was elucidated, certain receptor names may include a group of molecularly-distinct receptors, some of which may be inotropic, and some metabotropic. For example, the term "acetylcholine receptors" refers to both nicotinic acetylcholine receptors, which are inotropic, and muscarinic receptors, which are metabotropic. A similar situation exists for "glutamate" (Nakanishi), "serotonin" (Peters, *et al.*) and certain other receptors. Further, it will be understood that the agonist binding site of transmembrane receptors may be on the extracellular portion (*e.g.* nicotinic acetylcholine receptors (nicotinic AChRs), intracellular portion (*e.g.* cAMP receptors) or either, depending on the receptor subtype. For example, the ATP binding site is on the *extracellular* side in the case of calcium-selective receptors opened by ATP, and on the *intracellular* side in the case of potassium-selective receptors closed by ATP (Barnard, *et al.*, Bean, *et al.*).

According to methods of the present invention, cell biosensors may be derived from cells which are known to express a specific receptor under known conditions. For example, PC12 cells are known to express a number of receptors and ion channels (*e.g.* Shafer, *et al.*), including acetylcholine (both nicotinic (Greene, *et al.*, 1976) and muscarinic (Jumblatt, *et al.*) receptors, ATP receptors (Fasolato, *et al.*) and bradykinin receptors (Fasolato, *et al.*).

The acetylcholine receptors on PC12 cells resemble neuronal ACh receptors more than muscle ACh receptors. Properties of neuronal ACh receptors are reviewed, for example, by Sargent.

Many different receptors can be used with the methods of the present invention, provided that binding of a selected ligand alters the function of the receptor in a way detectable by a cell condition reporter.

Examples of inotropic receptors suitable for use with methods of the present invention include muscle and neuronal nicotinic acetylcholine receptors, γ -aminobutyric acid A (GABA_A) receptors, glycine receptors, glutamate receptors (including kainate-type, quisqualate-type and NMDA type), 5-HT₃, ATP receptors, cGMP receptors and cAMP receptors. The physiological properties of the above receptors, expressed *in vitro*, have been reviewed, for example, by Barnard, *et al.*

Within these and other inotropic receptors, there may exist a considerable heterogeneity among members of one class. The glutamate family of receptors, for example, has a particularly large number of variants, some of which are selectively sensitive to different ligands, such as NMDA (*e.g.* Nakanishi). The family may be more appropriately called an

"excitatory amino acid" receptor family, because it is possible that amino acids other than glutamate (such as aspartate) are the natural ligand for the receptor in some circumstances.

Inotropic receptors are typically comprised of 4-6 homologous subunits, typically termed α , β , γ , δ , ϵ and ζ . The pentameric muscle nicotinic acetylcholine receptor, for example, is composed of 4 homologous subunits in the stoichiometry $\alpha_2\beta\gamma\delta$ arranged around a central cation-permeable pore. Molecular cloning has demonstrated that cDNAs encoding most receptor subunits are each members of a family of highly homologous but distinct sequences arising from alternative splicing and/or different genes. Expression studies suggest that in some cases, few if any variations on the "natural" subunit composition form functional receptors, while in other cases, functional receptors may be made from most of the different combinations possible with the clones at hand. Some of the resulting variants may have ligand-binding and/or permeation properties that differ from the native receptors, and that may be exploited for methods of the present invention. For example, certain subunit compositions of AMPA-Kainate (non-NMDA) excitatory amino acid receptors have a low calcium permeability, while others have an increased permeability (see, for example, review by Nakanishi).

According to methods of the present invention, the ability to construct biosensors with specific properties (*i.e.* biosensors having specific receptors), and couple the biosensors with a separation means, is an advantage for the detection a selected ligand in a mixture of ligands. In other words, by judiciously choosing cells expressing (either natively or recombinantly) the appropriate receptor subunits, a cell biosensor may be constructed which is sensitive to a selected ligand, and which generates a known biosensor response (such an increase in calcium coupled with a calcium-sensitive dye) that can be detected.

For example, a cell biosensor containing a calcium-permeable AMPA-kainate, NMDA or nicotinic acetylcholine receptor may be used in conjunction with a calcium-sensitive dye, because these receptor types are permeable to calcium, and opening of the receptors results in an influx of calcium through the receptor channel (given that the electromotive force for calcium is inward). Alternatively, a cell biosensor containing an inotropic GABA or glycine receptor may be used with a chloride-sensitive cell condition reporter, such as a chloride-sensitive dye, since those receptors are generally anion-selective channels.

It will be understood that inotropic receptors may be present in intracellular membranes, as well as the plasma membrane of a cell biosensor. For example, the IP_3 receptor is located in the endoplasmic reticulum (ER) and is responsible for the release of calcium from the ER in response to IP_3 (the elevation of IP_3 in the cell may, in turn, be a response to the activation of a plasma membrane receptor, such as a muscarinic acetylcholine receptor; Hille).

The ryanodine receptor, also an intracellular calcium-release channel, was first recognized in the sarcoplasmic reticulum (SR) of muscle. It is partially-opened by ryanodine, and may be fully activated by calcium or caffeine (Hille).

Such "intracellular membrane" receptors may be used in conjunction with a cell biosensor in their native state -- that is, expressed in an intracellular membrane (*e.g.* ER) of the cell biosensor, or they may be recombinantly expressed on the plasma membrane of a host cell.

A large number of metabotropic receptors may be suitable for use with the present invention. Plasma membrane-associated receptors may be grouped into at least three "superfamilies" of receptors (Hille): (A) "classical" G-protein-coupled receptors have seven transmembrane segments, the ligand-binding site is at least partially associated with a transmembrane domain, and the site of G-protein interaction is cytoplasmic, (B) tyrosine kinase, or growth factor receptors have one transmembrane segment linking a large, glycosylated extracellular ligand-binding domain with a large intracellular portion that usually includes a protein tyrosine kinase domain and a site for autophosphorylation, and (C) guanylyl cyclase family that is similar to the growth factor receptors, except that the intracellular portion has a guanylyl cyclase domain, rather than a tyrosine kinase domain, and also contains another protein kinase domain.

A wide variety of metabotropic receptors falling, for example, into each of the above three classes is known in the art. The following are a few specific examples of such receptors.

Epidermal growth factor (EGF) receptors are members of the tyrosine kinase family of receptors. Activation of the receptor initiates a cascade of events (Carpenter, *et al.*, Wells, *et al.*) that results in internalization of the receptor and a rise in cytosolic free calcium.

An atrial natriuretic peptide (APN) receptor is a member of the guanylate cyclase family of receptors (Chinkers, *et al.*). Activation of this receptor by APN results in an increase in cGMP. Detection of activation of this receptor on a cell biosensor may be accomplished, for example, by co-expressing a cGMP-sensitive ion channel in the cell biosensor.

The 5HT_{1c} receptor used in experiments described herein is a member of the seven transmembrane segment G-protein-coupled receptor family. Activation of this receptor expressed in *Xenopus* oocytes results in an increase in intracellular calcium, presumably through an IP₃ pathway. The calcium then presumably activates calcium-sensitive chloride channels normally present in the oocyte plasma membrane (Gunderson, *et al.*) and results in an inward current (Julius, *et al.*).

A receptor for substance P, considered to function as a neuropeptide or modulator in the central and peripheral nervous system, is also a member of the seven transmembrane domain G-protein-coupled receptor family (Hershey, *et al.*), as is a substance K receptor, as is the ET_B receptor for endothelin (Sakurai, *et al.*, Arai, *et al.*), a peptide initially identified
5 in vascular endothelial cells. Other examples of receptors in this family include an interleukin-8 (IL-8) receptor (Murphy, *et al.*, Holmes, *et al.*), and a human thromboxane A₂ receptor (Hirati, *et al.*). Activation of the receptors identified above results in an increase in intracellular free calcium, presumably through an IP₃ pathway.

Several putative odorant receptors have recently been cloned (Buck, *et al.*). These
10 receptors also belong to the seven transmembrane segment G-protein-coupled receptor family. Cell biosensors containing odorant receptors may be particularly advantageous for use with methods of the present invention. The olfactory system can differentiate among thousands of different odorant molecules through a family of perhaps several hundred different G-protein-coupled receptors (Buck, *et al.*). A number of different odorant receptors have already been
15 cloned (*e.g.* Permentier, *et al.*). The odorant molecules can be divided into several "odor classes", which include fruity, such as citralva and citraldymethylacetal; herbaceous, such as eugenol and ethylvanillin; minty, such as menthone and eucalyptol, floral, such as geraniol and hedione; and putrid, such as pyrrolidine and pyrazine. The molecules can also be grouped by chemical classes, which include aromates, such as coniferan and helional; aldehydes, such as
20 lyral and lillial; amines, such as triethylamine and phenylethylamine; organic acids, such as isovaleric acid and butyric acid; sulphhydryls, such as 2-mercaptoethanol and furfurylmercaptan; methoxypyrazines, such as 2-isobutyl-3-methoxypyrazine and methoxypyrazine; and alkylpyrazines, such as 2,3,5-trimethylpyrazine and 2-methylpyrazine.

The cellular response to odorants binding to odorant receptors is typically an elevation
25 in cAMP (Breer, *et al.*), though IP₃ may also be involved (Boekhoff, *et al.*). It is apparent that at least some odorant receptors may exhibit a relatively "broad tuning" - being responsive to several odorant molecules, while others apparently have a much narrower range (Raming, *et al.*). Expression of selected odorant receptors with known tuning and selective properties in cell biosensors having, for example, a calcium indicator dye or the cAMP detector discussed
30 above, may provide a method for specifically detecting a wide variety of "aromatic" separated ligands.

B. Recombinant Expression of Receptors

According to methods of the present invention, receptors in cell biosensors that are specific for a selected ligand may be normally or recombinantly expressed by the cell from which the cell biosensor is derived. A large amount of information is available on the specific
5 receptors expressed by selected cell types. Examples have been provided above, in particular, the receptors expressed by PC12 cells. Following the teachings disclosed herein, one of skill in the art may readily select any of a number of cells, expressing specific receptors and known to those skilled in the art, for use as cell biosensors.

Similarly, following the guidance presented herein, one of skill in the art may choose
10 to recombinantly express any of a variety of receptors using methods known to those skilled in the art. Several different methods have been used for recombinantly expressing specific receptors in host cells (Gould, Conn, 1991b). The methods typically employ standard cellular and molecular techniques (Sambrook, *et al.*, Ausubel, *et al.*), with a focus on protein expression techniques (Goeddel, Kriegler), and may include special considerations depending
15 on the nature of the receptor being expressed. Such considerations may include (i) targeting transmembrane receptors to express appropriately in the plasma membrane of the host cell, (ii) providing a system capable of appropriate post-translational modification, and (ii) co-expression of multiple subunits in the same cell for heteromultimeric receptors. Several examples of expression systems which address these considerations are reviewed below.

Perhaps the most widely-used expression system for transmembrane, multimeric
20 receptors is the *Xenopus laevis* oocyte. *Xenopus* oocytes provide a simple, rapid and transient expression system that can easily accommodate heteromultimeric receptors. The oocytes contain ~50-100 ng of endogenous maternal cytoplasmic mRNA, but translation of this message is largely inhibited by the presence of various inhibitory proteins. The *in vitro*
25 translation machinery in the oocyte, however, is capable of correct post-translational modification, proteolytic cleavage and plasma membrane insertion (Wang, *et al.*).

To recombinantly express a message encoding a specific receptor, the mRNA(s) encoding the receptor is injected, for example, into a collagenased oocyte, and expression of the mRNA is assayed anywhere between 24 hours up to one week following injection. A
30 detailed description of the oocyte expression protocol is provided in Example 2, herein. In addition, a number of references specifically review this procedure (*e.g.* Gurdon, *et al.*, Leonard and Snutch, and Wang, *et al.*). Further, numerous groups have used the oocyte system for receptor expression (*e.g.* White, *et al.*, Meguro, *et al.*, Hollmann, *et al.*, Zagotta, *et al.*, Monyer, *et al.*, and McEachern, *et al.*).

It may also be desirable to construct cell biosensors derived from cell lines expressing a specific receptor. Several groups have reported methods for transforming cells, particularly mammalian cells, with sequences encoding various receptors.

Pritchett, *et al.*, transiently co-expressed GABA_A receptor α and β subunits in human embryonic kidney cells using the eukaryotic expression vector pCIS2 (Eaton, *et al.*). The vector contained the α and β subunits in a tandem arrangement, driven by a human cytomegalovirus (HCMV) promoter-enhancer. The vector was introduced using a modified CaPO₄ precipitation technique (Chen, *et al.*, 1987).

Rich, *et al.*, and Gregory, *et al.*, used the vaccinia virus-T7 hybrid system, developed by Fuerst, *et al.*, and Elroy-Stein, *et al.*, to express the cystic fibrosis transmembrane conductance regulator (CFTR) in HeLa and JME/CF15 (a CF airway epithelial cell line) cells. Advantages of this system include (i) infection and expression of a wide variety of eukaryotic cells, (ii) the virus provides the enzymes necessary for transcription in the cytoplasm of the infected cell, eliminating the need for nuclear processing, (iii) the gene product can be correctly processed and targeted to the cell surface, and (iv) a high percentage of host cells express the recombinant DNA. A similar system has also been used to express potassium channels (Leonard, *et al.*).

Claudio, *et al.*, 1987b, stably integrated the α , β , γ and δ subunits of the *Torpedo californica* nicotinic AChR into the genome of a thymidine kinase deficient (*tk*⁻) adenine phosphoribosyltransferase deficient (*aprt*⁻) murine fibroblast L-cell using a simian virus 40 (SV40) expression vector (Claudio, *et al.*, 1987a) containing all four subunits.

Scheuer, *et al.*, stably expressed sodium channels in CHO cells by co-transfecting rat IIA sodium channel cDNA in pECE (Ellis, *et al.*) under control of the SV40 early promoter (pVA222) with pSV2neo.

Expression vectors suitable for expression of receptors are also available from a variety of commercial sources. For example, Clontech (Palo Alto, CA) offers a baculovirus expression system which utilizes insect cells as host cells to express recombinant proteins. Standard eukaryotic expression vectors are available from Clontech, Stratagene (La Jolla, CA), Promega (Madison, WI) and other suppliers.

30

C. Cellular Responses to Receptor Activation

According to methods of the present invention, the binding of a selected ligand, present in a mixture of ligands, to a specific receptor may be selectively detected using a cell biosensor having the specific receptor and containing a cell condition reporter, provided that the cell

biosensor is used in conjunction with a means to separate the selected ligand from the mixture of ligands. The response of the cell biosensor to ligand binding may be a change in the transmembrane voltage, intracellular free calcium concentration, or the like, which is in turn detected by a cell condition reporter.

5 As discussed above, a the activation or inhibition of inotropic receptors typically results in a change in the transmembrane voltage, and possibly intracellular calcium concentration. Activation of a metabotropic receptor typically results in an increase in the concentration of specific second messengers. These may be detected directly (for example, calcium or cAMP), or indirectly, for example, following binding of the second messengers to targets, such as other
10 inotropic receptors (sensitive to intracellular agonists). An example of an indirect detection scheme detailed herein is the response of oocytes to serotonin in Example 2. Activation of the expressed 5-HT_{1c} receptor presumably mobilizes internal stores of calcium, which in turn open a calcium-sensitive chloride channel. The electrical response to the opening of the chloride channel is detected by the cell biosensor in the example.

15

D. Ligands

Selected ligands separated from a mixture of ligands may be receptor agonists, antagonists, competitive inhibitors, or non-competitive inhibitors. They include endogenous ligands, such as acetylcholine, and exogenous ligands, such as toxins with an affinity for a
20 specific receptor (*e.g.* α -bungarotoxin. The solution bathing the biosensor may contain additional receptor agonists, antagonists, competitive inhibitors, non-competitive inhibitors and the like. These additional components may interact with, enhance, or inhibit the binding of the selected ligand to a specific receptor, and accordingly, may be used to confirm the identity of a selected ligand or otherwise facilitate the interpretation of information available from the cell
25 biosensor.

For example, according to the teachings of the present invention, interpretation of signals from cell biosensors normally expressing a specific receptor may be complicated by the fact that a given cell is likely to be expressing a variety of receptors other than the selected receptor. Because many different receptors can result in a similar detectable response (*i.e.* a
30 voltage change or an increase in free calcium concentration), the use of specific receptor antagonists is an important aspect of the present invention in confirming the identity of the receptor responsible for a particular cell biosensor response. As discussed above, antagonists may be applied either locally to a cell biosensor, for example, by way of an additional capillary, or simply introduced into the recording solution.

Ligands may bind to the extracellular portion of a transmembrane receptor, membrane portion of a transmembrane receptor, or the intracellular portion of a transmembrane receptor. Ligands can also, of course, bind to any portion of an intracellular receptor. Ligands that bind intracellularly need to access the intracellular portion of a cell biosensor. If the cell biosensor is a portion of an intact cell with ready access to intracellular domains (such as an inside-out patch or a permeabilized cell), access does not pose undue difficulty. If, on the other hand, the cell biosensor is an intact cell or cells, and the ligand is not capable of diffusing across the plasma membrane, the ligand may need to be transported into the cell by an endogenous or exogenous transmembrane transporter molecule.

10 Ligands may be obtained from a variety of sources. An exemplary source of a mixture of ligands is a cell or tissue extract. This source may be particularly advantageous when information is desired as to the identity of a putative endogenous ligand for a specific receptor. The mixture may include substances to stabilize the state of ligands in the mixture, for example, protease inhibitors.

15 Alternatively, a mixture of ligands may be obtained from a combinatorial library, such as a peptide or chemical compound library (Houghten). Combinatorial libraries are typically screened by introducing a complex mixture species to a screening preparation, and if a positive response is obtained, repeating the process with lower-complexity mixtures until the compound having the desired activity is identified. Using methods of the present invention, the complexity of the mixture is reduced on-line, by separating the mixture using a capillary-based separation means prior to applying the components to a cell biosensor. The individual species in the library are detected serially, as described above.

25 In a related aspect, a mixture of receptor antagonists, such as conotoxin venom (Olivera, *et al.*), may be separated and screened in combination with a receptor agonist constitutively present in the vicinity of the cell biosensor. As described above, the agonist may be applied using, for example, a second capillary whose effluent is also directed at the cell biosensor detection field. By judiciously employing, for example, bath perfusion and continuous scanning (as described above), desensitization of the receptor may be avoided, and selected antagonistic ligands reaching the cell biosensor may result in a decrease in the receptor response.

30

VII. UTILITY.

As detailed above, methods of the present invention have a variety of uses. Further, the methods provide a number of advantages over methods utilized in the prior art. For

example, according to methods of the present invention, cell biosensors of the type described herein are not particularly useful at identifying a selected ligand in a mixture of ligands, unless they are coupled to an effective separation means. This is in large part because, as detailed above, a cell biosensor produces a similar signal (change in free intracellular calcium concentration and/or change in transmembrane voltage) in response to a wide variety of ligands. If a complex mixture of ligands is directly applied to a cell biosensor, interpretation of the response will be difficult, if not impossible. Even with the simultaneous use of a variety of receptor antagonists, interpretation will be challenging -- all that is required is for one of the ligands in the mixture of ligands to activate a receptor for which no antagonist is present, and activation of which, for example, increases intracellular free calcium concentration, and the response is uninterpretable.

According to methods of the present invention, however, such a biosensor is coupled to a means by which the complex mixture of ligand is separated, so that the effect of individual ligands present in the mixture may be assayed in a serial fashion. In this manner, selected ligands present even in a highly complex mixture containing many different ligands capable of generating a response of the cell biosensor may be identified, because the cell biosensor responses to the individual ligands are separated in time. The individual responses may be identified by running standards, as shown in Figures 2 and 3, and/or by using specific receptor antagonists, as shown in Figures 7, 8A and 8B, and discussed above.

The present invention offers a number of other distinct advantages. For example, methods of the present invention may be particularly useful in identifying ligands which are difficult to detect by traditional separation means, such as acetylcholine (Cooper, *et al.*). Further, the methods may be useful for identifying the biological activity of closely-related compounds, such as bradykinin and lys-bradykinin (Example 4). This approach may be used, for example, to assess the biological activity of breakdown products of a selected ligand, such a drug or therapeutic agent. In another example, an inactive precursor for an active peptide may be present in a sample, such as a blood sample. The rate of generation and identity of active (cleaved) species may be followed using methods of the present invention. In particular, if a non-invasive supplemental detector or detection means is positioned to detect the separated ligands before they are delivered to the cell biosensor, the rate of formation/degradation and biological identity of the precursor and various proteolysis products may be readily followed.

The invention may be similarly be applied to the study of other biologically-active compounds with limited lifetimes. Because both a traditional identification (with a supplemental detector) and the biological activity (with a cell biosensor) can be assessed within

seconds of one another, a correlation can be established between selected "peaks" detected with a traditional, supplemental detector, and the biological activity of those peaks as determined by a specific cell biosensor.

Methods of the present invention may also be used to screen for uncharacterized
5 endogenous agonists of known receptor, such as an opiate receptor. A tissue extract of a portion of the brain thought to contain the endogenous agonist may be prepared and analyzed according to methods of the present invention using, for example, a cell expressing an opiate receptor along with an inwardly-rectifying potassium channel (Reuveny, *et al.*, Dascal, *et al.*). Using traditional methods, one would typically fractionate the extract, resulting in perhaps a
10 hundred or more individual samples, and the fractionated samples would be analyzed one-by-one for activity. Using methods of the present invention, the fractionating and assaying can take place in a single run lasting as little as a few minutes.

Another exemplary use of methods of the present invention is for assaying the identity, concentration and release sites of neurotransmitters and hormones from individual cells (*e.g.*
15 *Aplysia* neurons). According to this aspect of the invention, large cells are dissected and plated in an assay dish which is placed at the inlet of a capillary-based separation means. The large cell is stimulated, for example, using electrical stimulation or agonists, such as peptides, and the inlet end of the capillary (etched down to a small diameter with, for example, hydrofluoric acid) is positioned at selected locations along the cell. A separation is performed, and the
20 separated mixture is detected with a cell biosensor expressing appropriate receptors (*i.e.* receptors for substances thought to be released by the large cell).

The above method may also be applied to assaying the identity, concentration and release sites of ligands, such as neurotransmitters from tissues, such as hippocampal slices (Nicoll, *et al.*). In particular, some vesicles contain more than one neurotransmitter. By
25 coupling a capillary-based separation means (to resolve individual components that may be released by stimulated cells) with a cell biosensor (expressing receptors for anticipated components released by stimulated cells), identification and quantitation of the relative amounts of the components is possible. Determining which ligands are released from which cells in response to specific types of stimulation, and how these responses differ in certain diseased
30 states (such as epilepsy) may be useful for the development and targeting of appropriate therapeutic compounds.

A related application is the determination of the content of single cells or cell organelles. As discussed above, individual cells, and to some extent, cellular organelles, comprise complex mixtures of ligands. Identification of selected ligands in those mixtures may

be desirable for the development of certain therapeutic and/or diagnostic molecular tools. According to this aspect of the invention, individual cells or organelles, such as vesicles, are introduced to the inlet end on a capillary-based separation means. The contents and biological activity of the cells or organelles may then be identified using a ligand separation means
5 coupled to a cell biosensor, or to a cell biosensor in combination with a supplemental detection means.

The following examples illustrate, but in no way are intended to limit the present invention.

10

MATERIALS AND METHODS

A. Capillary Electrophoresis

Ligands were separated by capillary electrophoresis (CE) using standard techniques (Grossman and Colburn, Gordon, *et al.*) with the following parameters/modifications. The
15 experiments were typically performed using a biosensor-compatible buffer (see below) as the electrophoresis buffer. Fused silica capillaries (I.D. = 15, 25 or 40 μm , O.D. = 360 μm) were obtained from Polymicro, Inc., Phoenix, AZ. Capillary lengths were typically between about 23 and 36 cm. The power supply was typically set to provide a field of 230 to 870 V/cm, resulting in electroosmosis (bulk solution flow) delivering separated positive,
20 neutral, and negative species to the cell biosensor.

B. Biosensor-Compatible Electrophoresis Buffers

Ligand mixture separations were carried out using cell biosensor-compatible buffers. A cell biosensor-compatible buffer is a buffer effective to maintain the cell biosensor in a stable
25 and functional condition for the duration of an experiment.

In those instances where the cell biosensor is an intact cell, a cell biosensor-compatible buffer is analogous to a physiologically-compatible buffer -- that is, a buffer that does not substantially alter the signal coming from, or disrupt the intact cell. In cases where the cell biosensor is, for example, a permeabilized cell, a cell biosensor-compatible buffer is one that
30 does not compromise the ability of the permeabilized cell to generate a detectable response to a selected ligand. Similarly, if the cell biosensor is a portion of a cell, such as a membrane patch, the buffer does not compromise the ability of the patch to generate the desired signal. In the case of an outside-out patch, the buffer may be similar to one used for an intact cell, such as an "extracellular" Ringer solution. In the case of an inside-out patch, the buffer may

be similar to an "intracellular" Ringer solution, such as one containing low calcium and high potassium.

Many examples of physiologically compatible buffers are known in the literature (*e.g.* Wallis). In experiments performed in support of the present invention, it was determined that
5 a mammalian Ringer solution can serve as an exemplary "extracellular" biosensor-compatible buffer for separations with capillary electrophoresis. The composition of the Ringer used in the present experiments (capillary electrophoresis (CE) Ringer) was as follows: 135 mM NaCl, 5 mM KCl, 10 mM glucose, 2 mM MgCl₂, 2 mM CaCl₂, and 10 mM HEPES (pH 7.35)

It will be understood by one skilled in the art that modifications to this composition can
10 be made without appreciably affecting the separation and/or physiological characteristics of the solution. For example, according to methods of the present invention, it is not required that the cell biosensor respond in a manner identical to the native cell from which it is derived; only that it respond in a predictable manner. Accordingly, components other than the selected ligand may be present in a biosensor compatible buffer, which affect the response of the
15 biosensor to the selected ligand. Such components may include substances, such as certain organic compounds, which facilitate the separation of a mixture of ligands using capillary-based separation means.

B. Eukaryotic Cells

20 1. Growth and Maintenance. Rat clonal pheochromocytoma (PC12) were obtained from the laboratory E. Shooter, Stanford University. NG108 cells were obtained from the laboratory L. Stryer, Stanford University. Both cell types can be obtained from the American Type Culture Collection ATCC (Rockville, MD). The cells were plated on an untreated #1 glass coverslip (Fisher Scientific, Pittsburgh, PA) constituting a portion of the
25 bottom surface of a 35 mm tissue culture dish (Fisher) in DMEM medium (Gibco/BRL Life Technologies, Gaithersburg, MD) supplemented with 5% heat-inactivated horse serum (HyClone Labs, Logan, UT), 10% fetal calf serum (FCS; Gibco/BRL), 1% 10 mg/ml glutamine (Sigma) and 1 % Penicillin/streptomycin solution containing 10,000 U/ml penicillin and 10 mg/ml streptomycin (Sigma), and maintained in a 5% CO₂ atmosphere until use (2-4
30 days).

C. Xenopus Oocytes

1. Isolation and Maintenance. *Xenopus* oocytes were isolated essentially as described by Zagotta, *et al.* Female *Xenopus laevis* were obtained from NASCO (Fort

Atkinson, WI) and maintained at room temperature (20-22°C). The frogs were anesthetized by immersing for 20 minutes in 0.1-0.2% ethyl m-aminobenzoate (tricaine; MS-222; Sigma Chemical Co., St. Louis, MO). A small incision was made on the abdomen and the ovarian lobes were removed into OR2 solution (82.5 mM NaCl, 2.5 mM KCl, 1 mM MgCl₂, 5 mM HEPES, adjusted to pH 7.6 with NaOH).

The follicular cell layer was removed by digestion with collagenase (2 mg/ml, type IA, Sigma) in OR2 solution with gentle agitation for 2-3 hours. Large (~1 - 1.5 mm diameter) stage V and VI oocytes were then transferred to ND96 solution (96 mM NaCl, 2 mM KCl, 1.8 mM CaCl₂, 1 mM MgCl₂, 5 mM HEPES adjusted to pH 7.6 with NaOH) and maintained at 18°C until used for injection with mRNA (typically a few minutes to a few hours).

2. Synthesis of Recombinant Receptor mRNA. Plasmid pSR1c, obtained from D. Julius (Julius, D.J., *et al.*, *Science* 241:558, 1988) was used to transcribe 5HT1c receptor cDNA *in vitro* using standard methods (Ausubel, *et al.*). Briefly, the plasmid was linearized with *NotI* (New England Biolabs, Beverly, MA), 2-5 µg of the linearized plasmid were suspended in 50 µl of a standard transcription buffer (Ausubel, *et al.*) containing 10 mM dithiothreitol (DTT), 0.5 mM each of ATP, cytidine triphosphate (CTP) and uridine triphosphate (UTP), 0.25 mM guanosine triphosphate (GTP), 0.3 mM m7G(5')ppp(3')G (all from Boehringer-Mannheim, Indianapolis, ID), 50 units "RNASIN" and 40 units T7 RNA polymerase (both from Promega, Madison, WI), and the mixture was incubated at 37°C for 1 hour. A second 40 unit aliquot of T7 polymerase was added and the mixture was incubated an additional hour.

The template DNA was removed by incubating with 2.2 µl RQ1 RNase-free DNase (Promega), and RNA was purified by extractions with phenol/chloroform (1:1, vol/vol) and chloroform, ethanol precipitated (with ammonium acetate), and resuspended in 10 µl diethyl pyrocarbonate (DEPC)-treated water. Prior to injection, the RNA was diluted to the desired concentration (typically 0.1 µg/µl) with DEPC-treated water.

3. Expression of Exogenous Receptors. Oocytes prepared as above were microinjected with ~50 nl of a solution containing ~0.1 µg/µl mRNA, prepared as above, using a Drummond Nanoject (Fisher Scientific, Pittsburgh, PA) pressure injector. Injection pepts were fashioned using a standard patch pipet puller (Narashige, Japan) set to produce pipets with long (~1.5 - 2 cm) tips. The tips were broken by poking a ChemWipe, and the pipets baked at >150°C for 4-5 hours to inactivate RNases. The pipets were backfilled with

a DEPC-treated saline solution and tips were filled with solution containing the RNA to be injected.

Injected oocytes were maintained in ND96 solution supplemented with 2.5 mM sodium pyruvate, 100 units/ml penicillin and 100 $\mu\text{g}/\text{ml}$ streptomycin (Pen-Strep mixture obtained from Sigma, cat # P0781) at 18°C. The oocytes were suitable for use as biosensors starting ~24 hours after injection.

EXAMPLE 1

OPTICAL DETECTION OF BIOSENSOR SIGNAL

10 Mammalian cells (PC12 or NG108 cells) plated on coverslips as described above were loaded with fluo-3 AM ester (Molecular Probes, Eugene, OR) at room temperature for ~ 0.5 h. The loading medium contained 18 μM fluo-3, 135 mM NaCl, 5 mM KCl, 10 mM glucose, 2 mM MgCl_2 , 2 mM CaCl_2 , and 10 mM HEPES (pH 7.35). After loading, the cells were placed in the same medium without fluo-3 for 0.5 h at room temperature. In many
15 experiments, 6 μM fluo-3 was introduced to the recording medium to replenish dye lost from the cells. This manipulation typically reduces the baseline decrease in fluorescence observed, for example, in Figure 9.

The cell end of the capillary was positioned about 20 to 40 μm from the cells, thereby directing capillary effluent over the cells. The channel of the capillary was slightly larger than
20 the diameter of the cell (see Figure 1B), enabling delivery of the effluent over the entire cell surface. Typically, a 15 μm or 25- μm I.D. capillary was used for separations, and 1 to 15 mammalian cells, such as PC12 cells, were used as the cell biosensor.

Alternatively, the effluent may be directed over selected portions of a single cell, or over a field of a plurality of cells, by selecting capillaries with appropriate I.D.s, cells with
25 appropriate diameters, and positioning the cell end accordingly.

Effluent species that evoke changes in $[\text{Ca}^{2+}]_i$ were detected with an epi-illuminated fluorescence microscope. Dishes containing the cells were transferred to the stage of a Diaphot-TMD-EF inverted fluorescence microscope (Nikon, Inc., Melville, NY), where they were maintained at ~ 35 to 37°C by heating the 100X (1.3 N.A.) oil-immersion lens used for
30 illumination and fluorescence collection. The cells were illuminated with 470–490 nm light (Nikon filter block, B-1A) and fluorescence ($\lambda > 520$ nm) was imaged onto an R928 photomultiplier tube (PMT; Nikon) with a Microflex PFX photomicrographic attachment (Nikon). The current from the PMT was converted to a voltage and amplified with a LF355N operational amplifier. High-frequency noise was removed by a low-pass filter with an RC time

constant of 1 second. The voltage signal was digitized by a "DAS" 8 analog- to-digital board (Kiethley MetraByte, Taunton, MA) and displayed with software written in QuickBasic (Microsoft, Redmond, WA) on an IBM AT-style personal computer.

5 A transmitted-light image taken through the microscope objective (Fig. 1B) shows how the outlet of a 25- μm i.d. capillary can be positioned above a single cell.

A. Changes in Intracellular Calcium - Ach/BK/ATP Mixture.

10 A standard solution of CE Ringer containing three ligands -- acetylcholine (ACh; 0.8 mM), bradykinin (BK; 20 μM), and adenosine triphosphate (ATP; 5 mM) was separated by capillary electrophoresis. The ligands were introduced by 5-second gravity injections (inlet elevated 10 cm above outlet) and were separated using an electric field of ~ 850 V/cm in a 23 cm 15 μm I.D. capillary. The capillary effluent was delivered to a group of 10 - 15 PC12 cells loaded with fluo-3 as described above. The tip of the capillary was positioned approximately 40 μm above the cells, allowing the effluent to diffuse uniformly over the cells.

15 The results are shown in Figure 2. Electropherograms are offset on the vertical axis to aid visualization. The negative baseline slope is caused by a decrease in the intracellular concentration of fluo-3, which can be partially stabilized by incorporating fluo-3 AM ester in the measurement buffer.

20 The trace labeled "Mixture", shows the fluorescence measured as a function of time as the capillary electrophoresis effluent was washed over the cells. The peaks in the signal, reflecting increased intensity of fluorescence, are due to increases in $[\text{Ca}^{2+}]_i$ following binding of ligands to their respective receptors. The increases in $[\text{Ca}^{2+}]_i$ are caused by release of calcium from internal stores and/or by entry of calcium through ligand- or voltage-gated ion channels (Pozzan, *et al.*, Sands, *et al.*).

25 Identification of the three peaks in the "Mixture" trace of Figure 2 can be accomplished by electrophoretically separating each ligand individually (Figure 2, traces "ACh", "BK", and "ATP"). Because of the relative charge-to-frictional drag ratios, acetylcholine migrates fastest to the sensor, closely followed by bradykinin and then by ATP. The position of the peaks in the individual ligand traces corresponds to the position of the peaks in the mixture trace,
30 facilitating identification of the mixture peaks. The absolute position of the ATP peak is somewhat variable due to the slow migration velocity of ATP (Yamamoto, *et al.*).

B. Changes in Intracellular Calcium - PC12 Lysate/Ach.

PC12 lysate was prepared as follows. PC12 cells grown and differentiated for four days in a 50 ml culture flask with 25 ml of PC12 growth medium (see above) further containing 25 ng/ml β -NGF (nerve growth factor; Boehringer-Mannheim, Indianapolis, IN),
5 were pelleted and lysed in 70 μ l of 70% methanol containing 0.1 mM eserine (to inhibit cholinesterase activity).

Approximately 500 pl of the lysate were introduced to the inlet end of a capillary by a 10-second gravity injection 10 cm above the outlet (Fishman *et al.*). This amount of lysate corresponds to $\sim 10^{-5}$ of the entire lysate volume. Since the cells in the flask were
10 differentiated at $\sim 10\%$ confluence (*i.e.*, $\sim 5 * 10^6$ cells were incorporated into the lysate), the 500 pl lysate volume corresponds to approximately 50 cells.

The lysate components were separated by capillary electrophoresis using a field of ~ 400 V/cm in a 25 cm 25 μ m I.D. capillary. The effluent was directed over 4-5 PC12 cells, as above. Fluo-3 AM ester was included in the buffer bathing the cells to aid in maintaining
15 a steady concentration of fluo-3 in the cells.

The results, in the form of a fluorescence signal as a function of time, are shown in Figure 3. The top trace shows a single peak of $[Ca^{2+}]_i$ change in the first 150 seconds of separation. This peak, which migrates to the cell biosensor in ~ 100 seconds, is identified as acetylcholine from comparison with the electropherogram produced by running an acetylcholine
20 standard solution (Figure 3, bottom trace).

EXAMPLE 2

ELECTROPHYSIOLOGICAL DETECTION OF BIOSENSOR SIGNAL

A *Xenopus* oocyte was microinjected as described above with serotonin 5HT1c receptor
25 mRNA and allowed to recombinantly express 5HT1c receptor. Two to four days after injection, the oocyte was positioned at the outlet of a separation capillary and voltage-clamped at -70 mV using a two-electrode voltage clamp (TEV-200; Dagan Corp., Minneapolis, MN) in the virtual-current mode. Intracellular Ag/AgCl electrodes were constructed with an initial input impedance of ~ 3 to 4 M Ω in 3 M KCl. The oocyte recording solution contained 140
30 mM NaCl, 2 mM KCl, 2 mM CaCl₂, and 10 mM HEPES (pH 7.2).

Serotonin (5-HT; 100 μ M) was introduced into to the inlet end of a fractured 40- μ m i.d. CE capillary by 20-second gravity injections (+13 cm above outlet). The fracture was located 26 cm from the inlet end of the 36 cm capillary. The ligand solution was electrophoretically separated by application of a ~ 250 V/cm field over the 26 cm portion of

the capillary between the inlet and the crack. The separated effluent was pushed through the remaining 10 cm portion by the electroosmotic flow induced in the 26 cm portion, and delivered to the oocyte. Mock separations were run with buffer blanks.

Plots of current as a function of time are shown in Figure 5. The top trace shows the signal obtained in response a separation using serotonin. A peak in current is seen ~ 8 minutes after injection of serotonin into the capillary. The center trace shows the current response for a blank (control) CE run, and the bottom trace shows a return of signal when 5-HT is separated again and directed at the same oocyte. A slight increase in the migration time of 5-HT is apparent between the top and bottom traces, presumably caused by a decrease in the electroosmotic flow rate. The results exemplified are representative of 5 experiments.

Control experiments utilizing oocytes that had not been injected with 5HT1c receptor mRNA showed no response for 5-HT following capillary electrophoresis.

EXAMPLE 3

15

LOCALIZED EFFECTS OF LIGANDS

Experiments were performed to address the spatial extent over which analytes delivered to cell biosensors exert their effects. The experiments utilized the tendency of many receptors, including nicotinic acetylcholine and bradykinin receptors, to desensitize following repeated applications of ligand (Hille, DeLorme, *et al.*, Briggs, *et al.*).

20

Bradykinin (250 μ M) in CE Ringer was introduced at 120 second intervals into the inlet end of a capillary and electrophoresed. The outlet was placed ~ 50 μ m above a group of PC12 cells. Data were collected as described in Example 1. Figure 6A shows successive responses to the same dose of bradykinin. It is apparent from the figure that the bradykinin receptors desensitize -- that is, repeat applications of similar amounts of agonist ligand generate successively smaller responses.

25

Figure 6B shows a similar experiment as that shown in Figure 6A, except that the coverslip containing the cell was moved a few hundred microns between each pulse of ligand, to place a fresh batch of cells under the cell end of the capillary. A robust signal was obtained with each pulse of bradykinin. The responses differ in size somewhat with respect to one another, since the different groups of cells differed in the number of cells they contained, and the different cells differed somewhat in the number of receptors expressed and the strength of their responses. Electrophoresis parameters -- Capillary length: 30 cm, I.D.: 20 μ m, Voltage: 330 V/cm.

30

Figures 6C and 6D show experiments where a group of cells was first exposed to repeated pulses as in Fig. 6A, and then the capillary was moved (during the period labeled "scan") over a new group of cells. The response of the new group was comparable to the initial response in the original group. Same experimental conditions as above.

5 The results indicate that (i) groups of cells under the capillary are uniformly stimulated and desensitized following repeat applications of ligand, and (ii) the concentration of the ligand falls off rapidly and dissipates with distance away from the capillary, leaving neighboring example groups of cells unaffected by repeat applications of ligand.

10

EXAMPLE 4

EFFECTS OF RECEPTOR ANTAGONISTS ON LIGAND-INDUCED BIOSENSOR SIGNALS

Cell biosensor responses to electrophoresed ligands were selectively blocked by specific receptor antagonists. The data were collected as described in Example 1. Figure 7 shows the effects of HOE 140 (Hoechst-Roussel Pharmaceuticals, Somerville, NJ), a bradykinin receptor
15 antagonist, on the response of PC12 cells to a mixture of acetylcholine (8 mM) and bradykinin (25 μ M). The bottom trace in the figure shows the response in absence of HOE 140, the top trace shows the response after the drug is added to the cell bathing solution to a final concentration of 800 μ M. Electrophoresis parameters -- Capillary length: 30 cm, I.D.: 20 μ m, O.D.: 350 μ m, Voltage: 10 kV, Current: \sim 20 μ A, distance of capillary outlet from cells: \sim 40
20 μ m.

The data show that HOE 140 essentially eliminated the biosensor response to bradykinin, but had no effect on the acetylcholine response.

Figures 8A and 8B show the effects of atropine (Sigma Chemical Co., St. Louis, MO) and α -bungarotoxin (Sigma), both acetylcholine receptor antagonist, on a cell biosensor
25 response to a mixture of acetylcholine (8 mM) and bradykinin (25 μ M). Figure 8A shows the response in absence of the antagonists, and Figure 8B shows the response after the drugs are added to the cell bathing solution to final concentrations of \sim 1 μ M (atropine) and \sim 1 μ M (α -bungarotoxin). Electrophoresis parameters -- Capillary length: 30 cm, I.D.: 20 μ m, O.D.: 350 μ m, Voltage: 10 kV, Current: \sim 20 μ A.

30 The acetylcholine antagonists reduced the biosensor response to acetylcholine by approximately a factor of 10 (compare the first peak (Ach) in Fig. 8A with the first peak (Ach) in Figure 8B), but did not affect the response to bradykinin.

EXAMPLE 5RESOLUTION OF RELATED COMPOUNDS

Methods of the present invention may be used to separate and resolve distinct ligands having similar chemical characteristics.

- 5 Data were collected as described in Example 1 from a group of PC12 cells. Electrophoresis parameters -- Capillary length: 30 cm, I.D.: 20 μm , O.D.: 350 μm , Voltage: 10 kV, Current: $\sim 20 \mu\text{A}$, distance of capillary outlet from cells: $\sim 40 \mu\text{m}$. Figure 9 shows the results a capillary electrophoresis run which included acetylcholine (8 mM), bradykinin (25 μM) and Lys bradykinin (25 μM). All three ligands are effectively separated and detected, as
- 10 evidenced by the three resolved peaks.

The data demonstrate that compounds having similar chemical characteristics, such as bradykinin and Lys bradykinin, can be resolved and detected using methods of the present invention.

- 15 While the invention has been described with reference to specific methods and embodiments, it will be appreciated that various modifications and changes may be made without departing from the invention.

IT IS CLAIMED:

1. A method for detecting a selected ligand in a mixture of ligands, comprising
 - (i) separating the mixture of ligands containing the selected ligand using a
5 capillary-based separation means,
 - (ii) delivering separated ligands to a cell biosensor having a receptor capable of binding the selected ligand, where the separated ligands are delivered to said biosensor in a cell biosensor compatible buffer, and
 - (iii) detecting binding of the selected ligand to the receptor.
- 10 2. A method of claim 1, wherein said separating includes separating a mixture of ligands derived from a tissue extract or a cell extract.
3. A method of claim 1, wherein said separating includes separating a mixture of
15 ligands obtained from a combinatorial library of ligands.
4. A method of claim 1, wherein said separating includes separating a mixture of ligands containing acetylcholine.
- 20 5. A method of claim 1, wherein said separating includes separating a mixture of ligands containing the selected ligand and degradation products of the selected ligand.
6. A method of claim 1, wherein said separation means includes a separation means selected from the group consisting of capillary electrophoresis, capillary gel electrophoresis,
25 capillary electrochromatography, capillary isotachopheresis, and affinity capillary electrophoresis.
7. A method of claim 1, wherein said cell biosensor comprises a cell.
- 30 8. A method of claim 7, wherein said cell biosensor comprises a cell recombinantly expressing a specific receptor.
9. A method of claim 7, wherein said cell biosensor comprises a cell in contact with a voltage-recording electrode.

10. A method of claim 7, wherein said cell biosensor comprises a *Xenopus* oocyte.
11. A method of claim 7, wherein said cell biosensor comprises a mammalian cell.
- 5 12. A method of claim 7, wherein said cell biosensor comprises a cell having a cell condition reporter.
13. A method of claim 12, wherein said reporter is a calcium-sensitive dye.
- 10 14. A method of claim 1, wherein said cell biosensor comprises a group of cells.
15. A method of claim 1, wherein said cell biosensor comprises a portion of an intact cell.
- 15 16. A method of claim 15, wherein said cell biosensor comprises an outside-out or an inside-out patch.
17. A method of claim 1, wherein said selected ligand is an agonist or an antagonist of the receptor.
- 20 18. A method of claim 1, wherein said detecting includes detecting a change in transmembrane voltage of a cell biosensor.
19. A method of claim 1, wherein said detecting includes detecting a change in
25 intracellular calcium concentration of a cell biosensor.
20. A method of claim 1, wherein said detecting includes detecting a change in intracellular cAMP concentration of a cell biosensor.
- 30 21. A method of claim 1, wherein said delivering includes delivering separated ligands to a cell biosensor which is in a bathing solution containing a receptor-specific antagonist, and wherein said detecting further comprises evaluating effects of the presence of the antagonist on the binding of the selected ligand to the receptor.

22. A method of claim 1, wherein said delivering includes delivering separated ligands to a cell biosensor which is in a bathing solution containing a receptor-specific agonist, and wherein said detecting further comprises evaluating effects of the presence of the agonist on the binding of the selected ligand to the receptor.

5

23. A method of claim 1, wherein said capillary-based separation means has an outlet end, and wherein said delivering includes delivering separated ligands to a cell biosensor which is attached at the outlet end of the capillary separation means.

10

24. A method of claim 23, wherein said cell biosensor is on a solid support that is removably attached at the outlet end of the capillary separation means.

25. A method of claim 1, further comprising repeating steps (ii) through (iii) a selected number of times, where each time said delivering is to a different cell biosensor.

15

26. A method of claim 1, where step (i) further comprises monitoring separated ligands using a supplemental detection means.

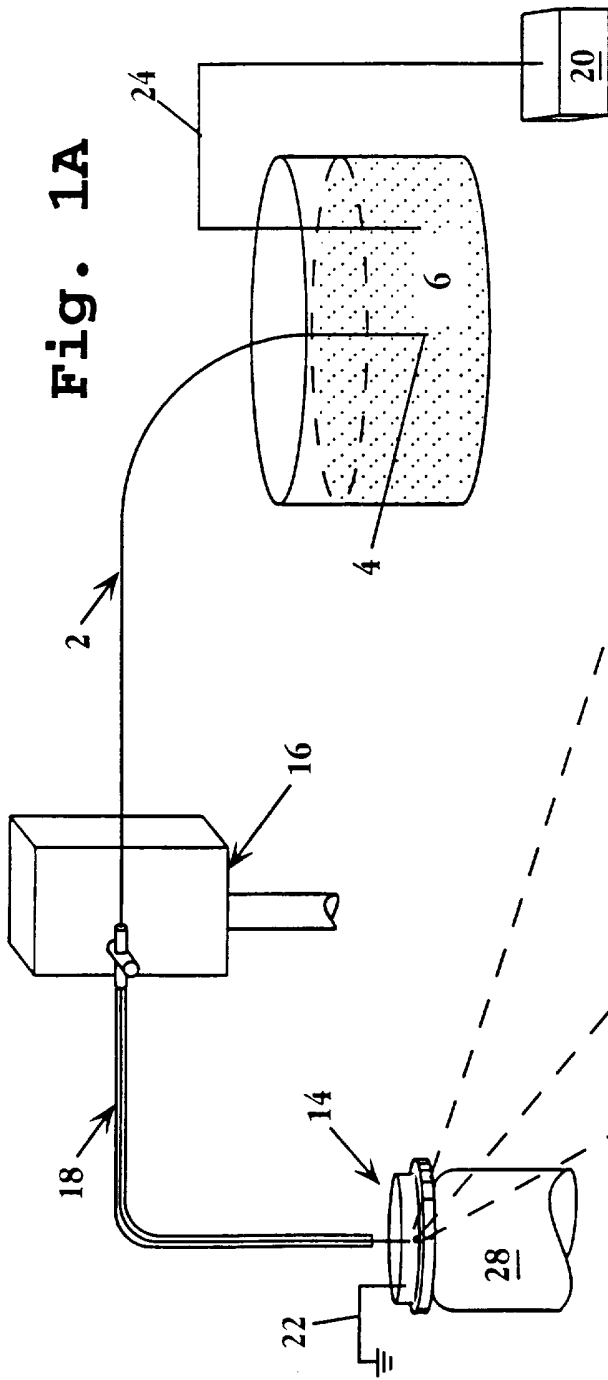

Fig. 1A

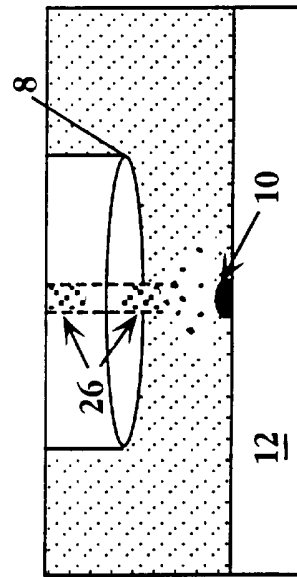

Fig. 1B

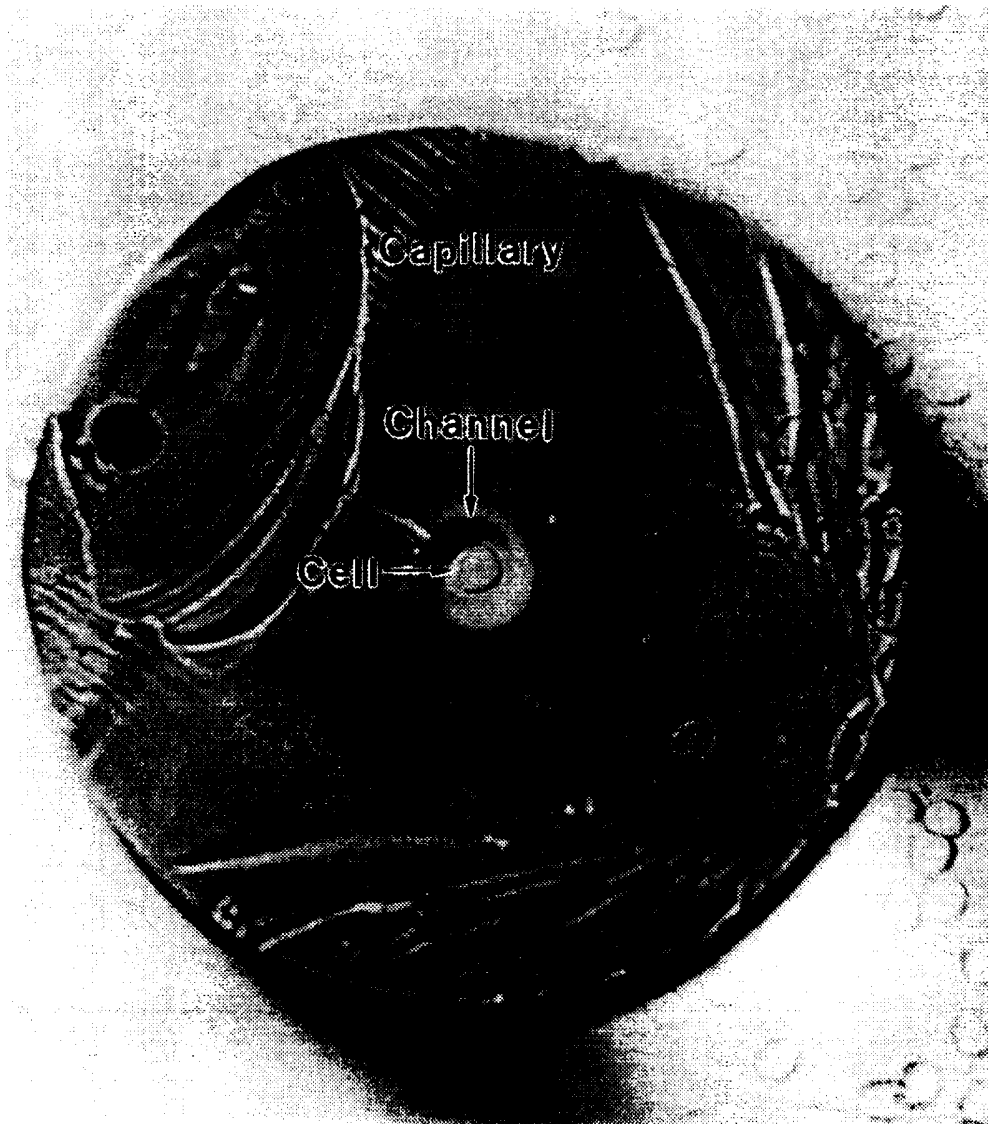

Fig. 1C

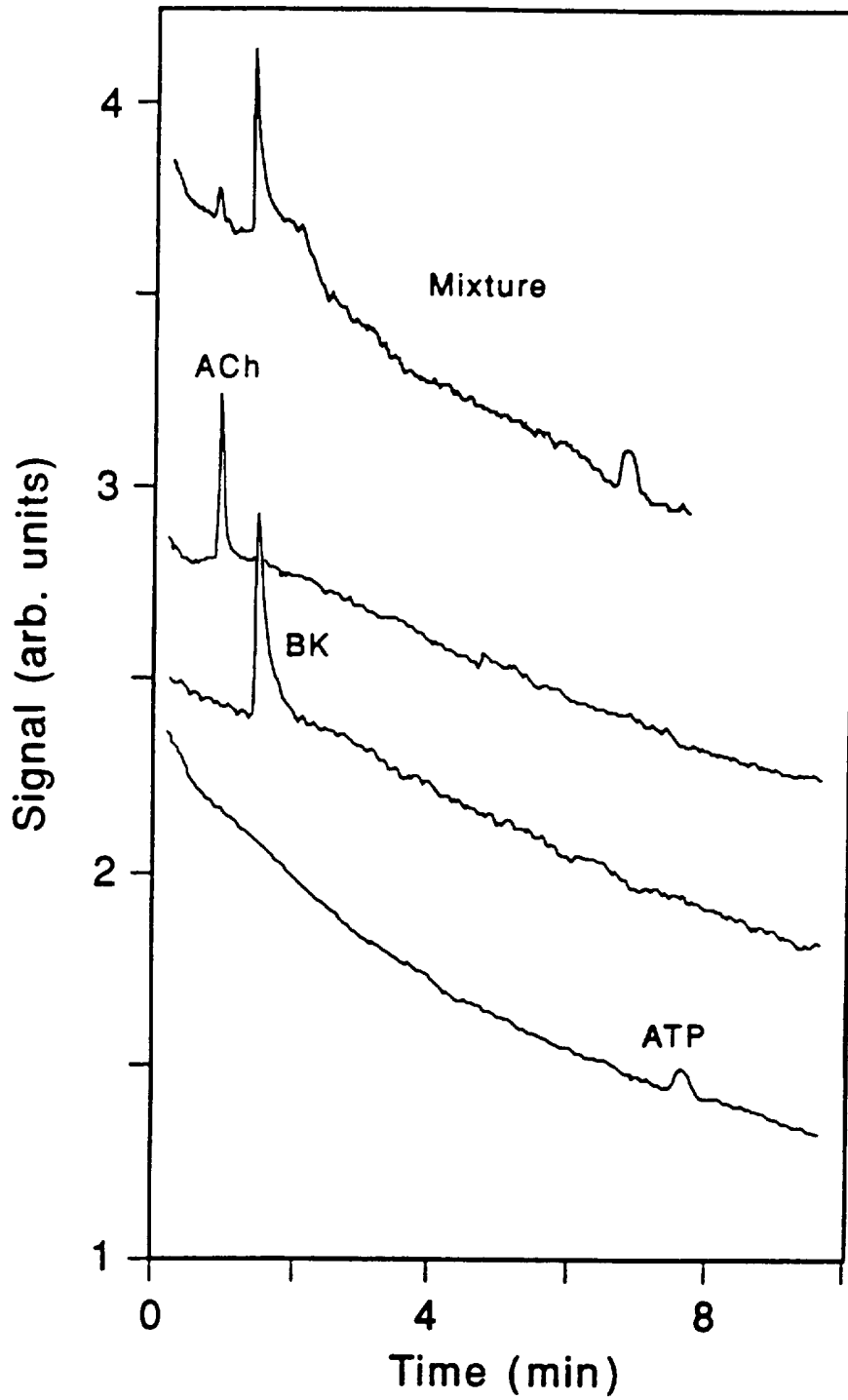

Fig. 2

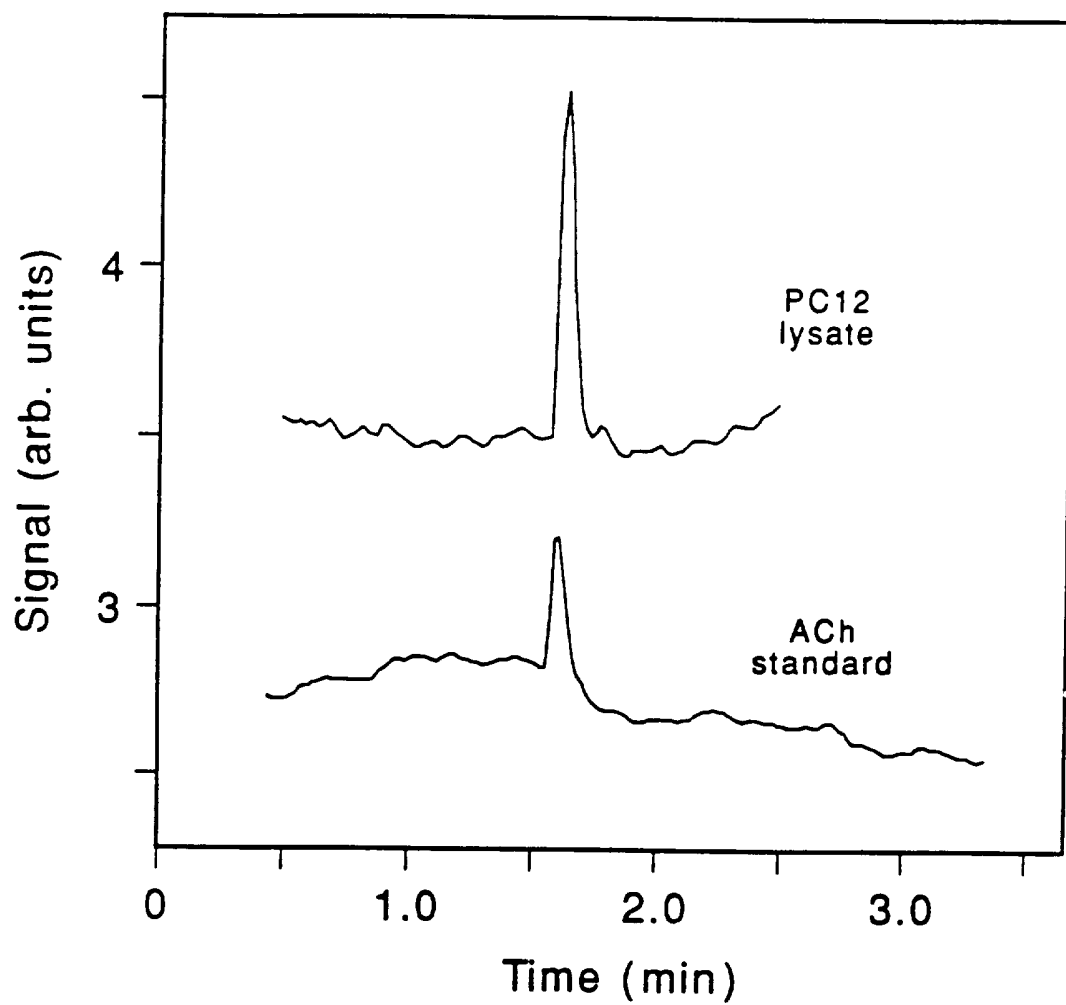

Fig. 3

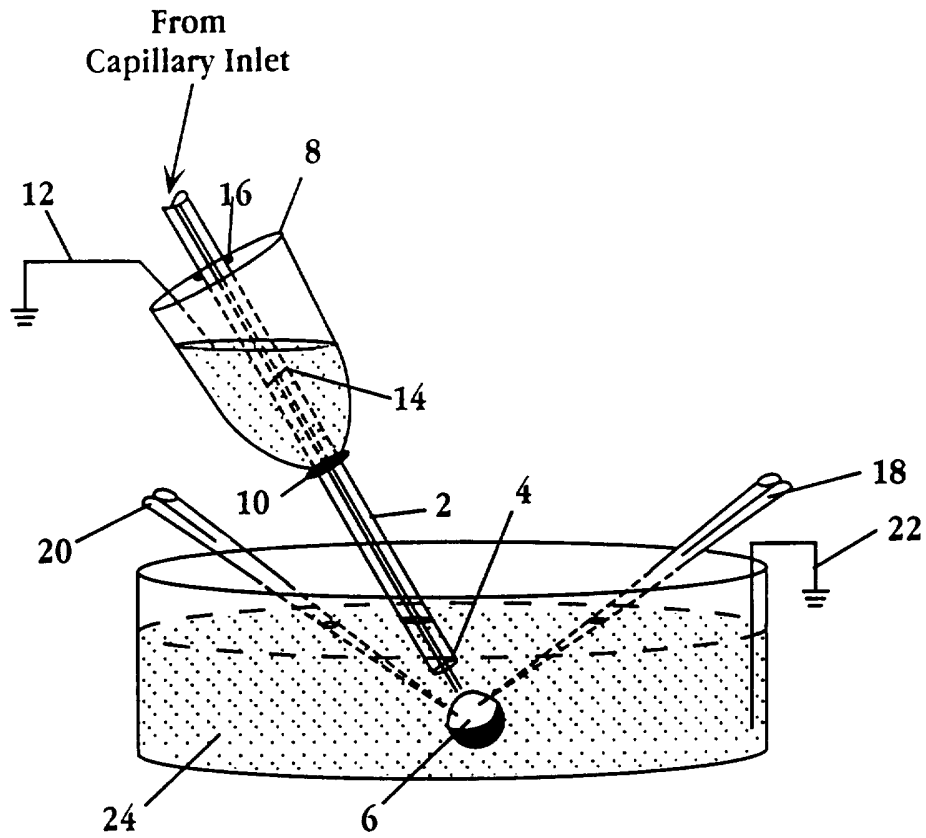

Fig. 4

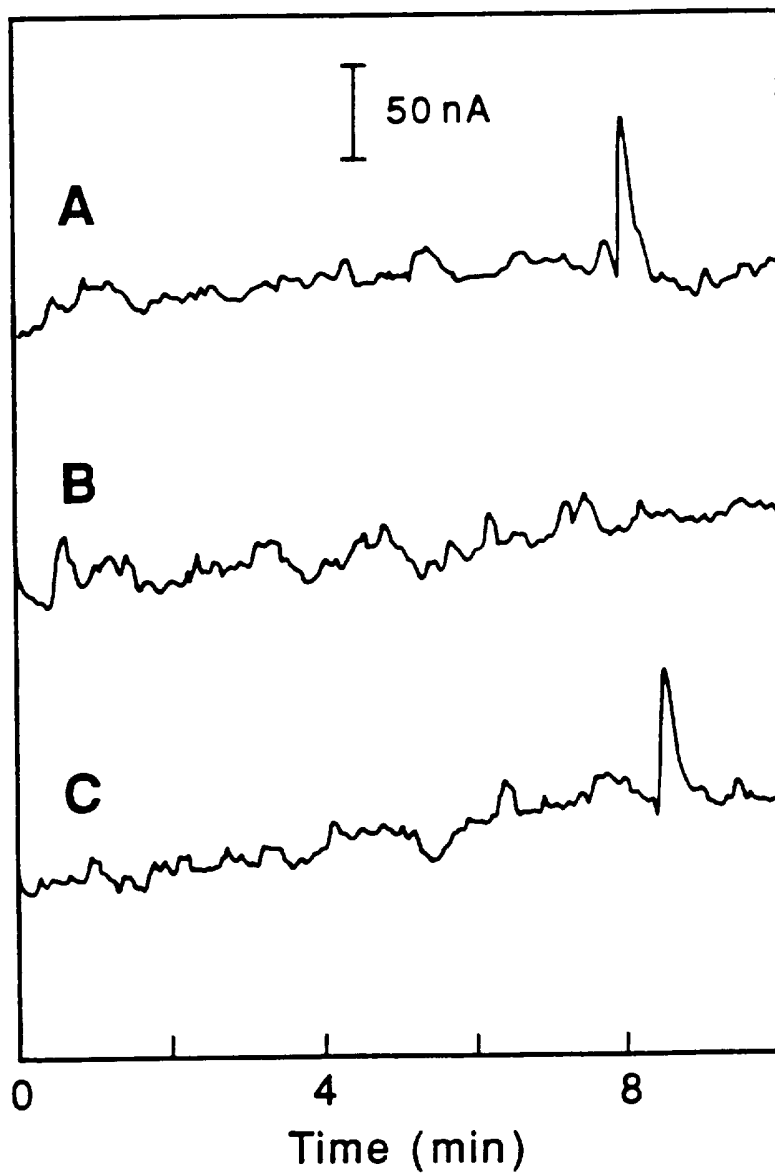

Fig. 5

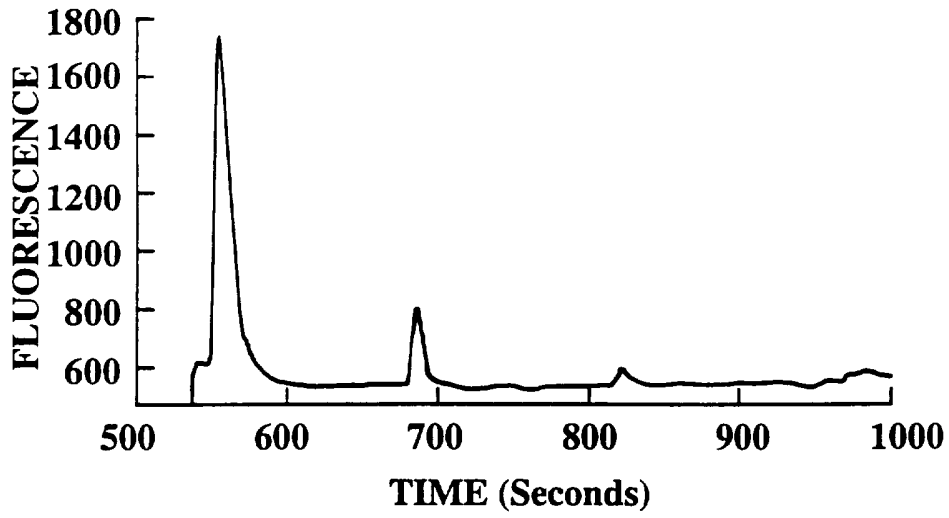

Fig. 6A

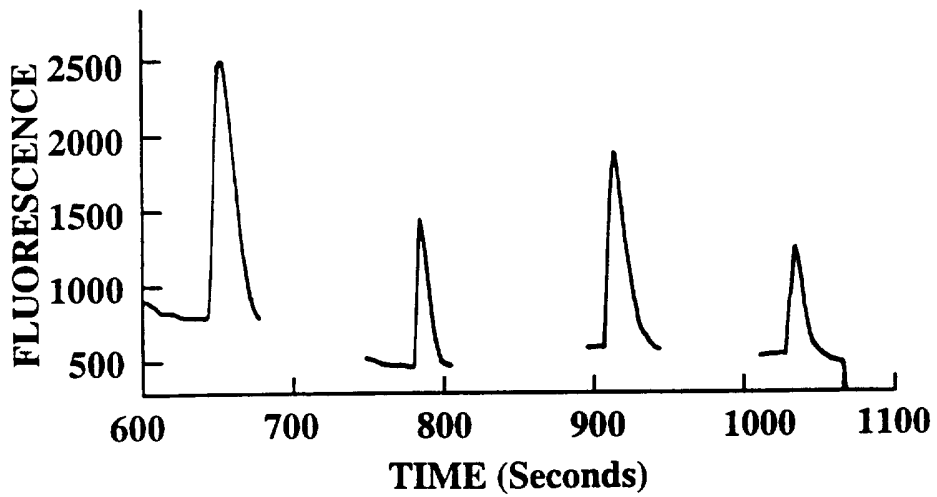

Fig. 6B

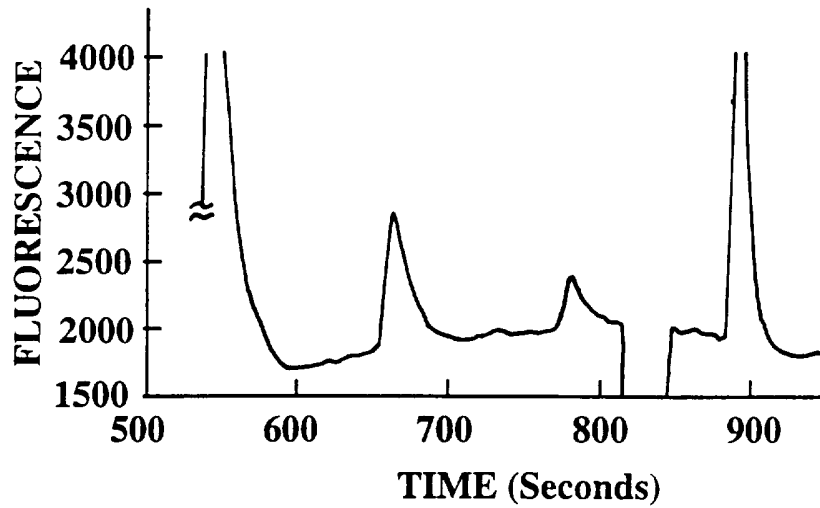

Fig. 6C

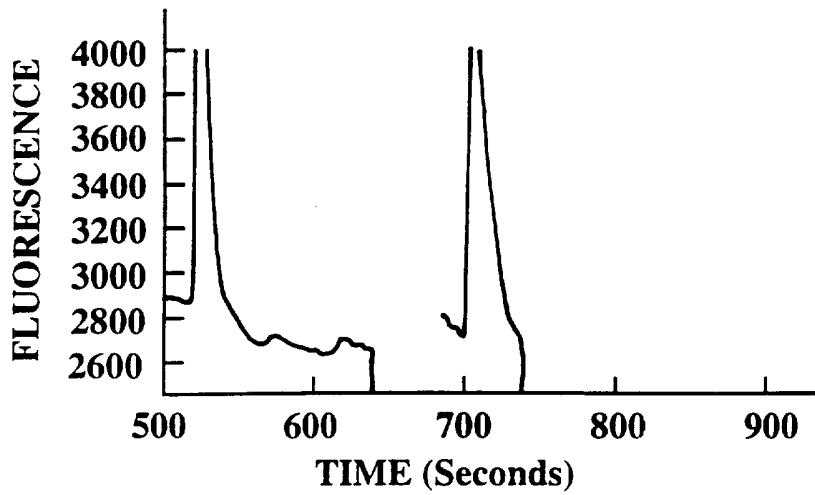

Fig. 6D

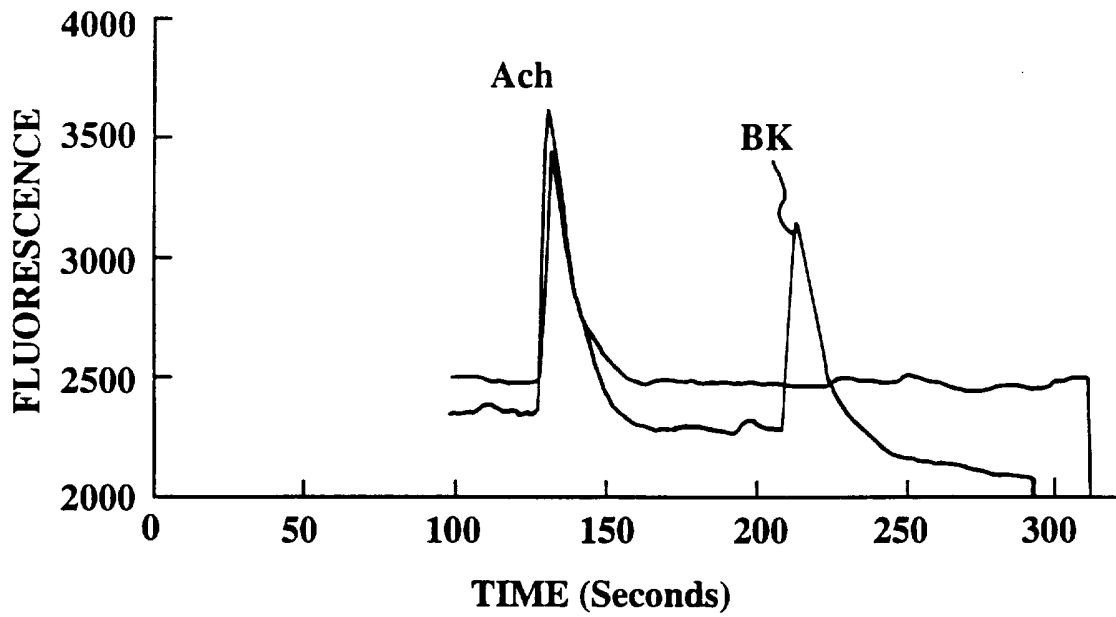

Fig. 7

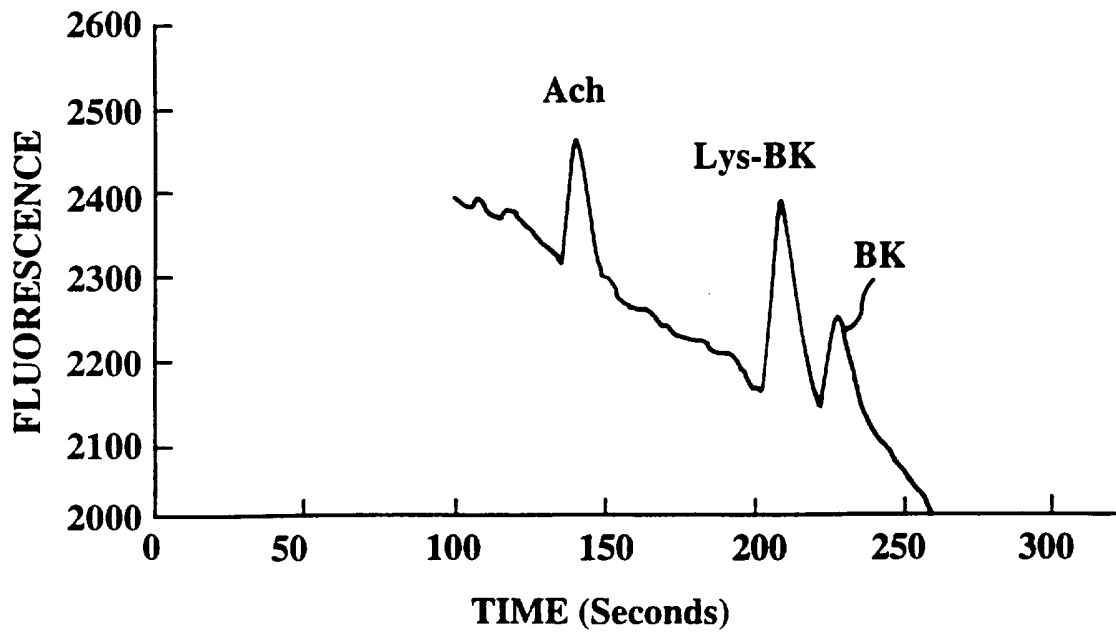

Fig. 9

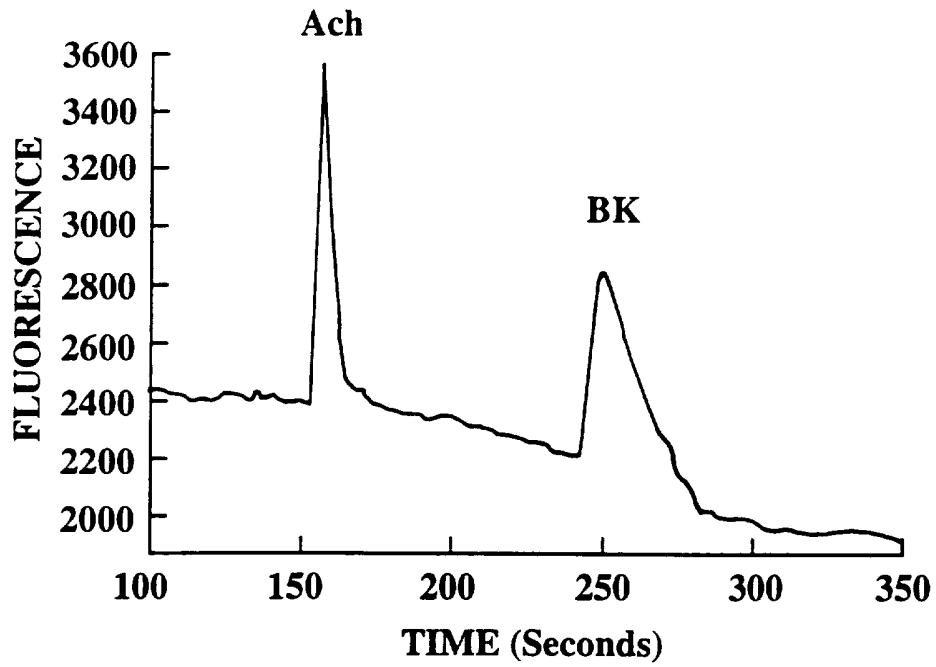

Fig. 8A

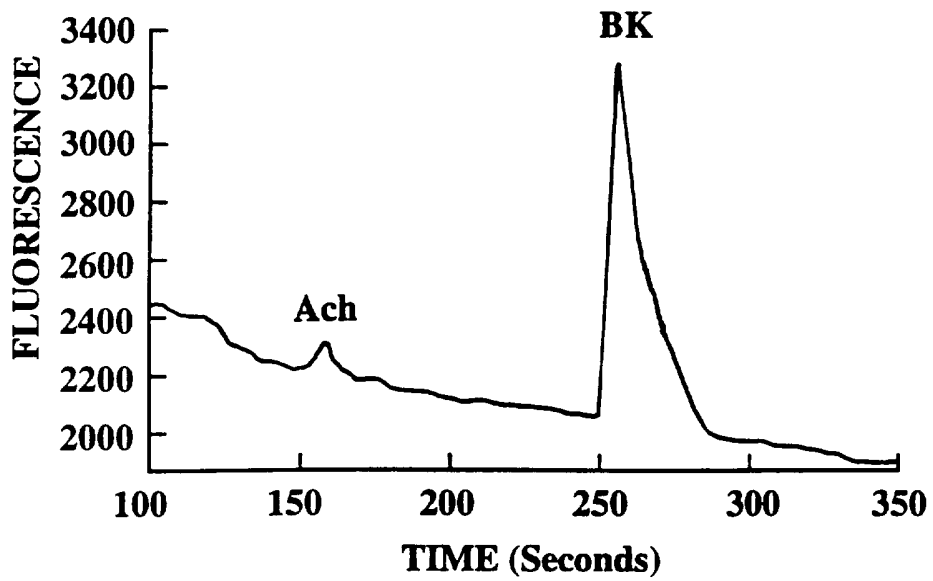

Fig. 8B

INTERNATIONAL SEARCH REPORT

International application No.
PCT/US95/12444

A. CLASSIFICATION OF SUBJECT MATTER

IPC(6) :G01N 21/76
US CL : 436/172

According to International Patent Classification (IPC) or to both national classification and IPC

B. FIELDS SEARCHED

Minimum documentation searched (classification system followed by classification symbols)

U.S. : 436/172; 435/7.1

Documentation searched other than minimum documentation to the extent that such documents are included in the fields searched

Electronic data base consulted during the international search (name of data base and, where practicable, search terms used)
Please See Extra Sheet.

C. DOCUMENTS CONSIDERED TO BE RELEVANT

Category*	Citation of document, with indication, where appropriate, of the relevant passages	Relevant to claim No.
Y	US, A, 5,348,633 (KARGER ET AL.) 20 September 1994, column 4, lines 25-34, column 2, lines 45-57.	1,25,26
Y	Journal of Organic Chemistry, Volume 58, issued 1993, Chu et al., "Using Affinity Capillary Electrophoresis to Identify the peptide in a peptide library that bind most tightly to Vancomycin," pages 648-652, see page 648 title, abstract and page 651, column 1, last paragraph.	1,3,6

Further documents are listed in the continuation of Box C. See patent family annex.

* Special categories of cited documents:	"T" later document published after the international filing date or priority date and not in conflict with the application but cited to understand the principle or theory underlying the invention
"A" document defining the general state of the art which is not considered to be of particular relevance	"X" document of particular relevance; the claimed invention cannot be considered novel or cannot be considered to involve an inventive step when the document is taken alone
"E" earlier document published on or after the international filing date	"Y" document of particular relevance; the claimed invention cannot be considered to involve an inventive step when the document is combined with one or more other such documents, such combination being obvious to a person skilled in the art
"L" document which may throw doubts on priority claim(s) or which is cited to establish the publication date of another citation or other special reason (as specified)	"&" document member of the same patent family
"O" document referring to an oral disclosure, use, exhibition or other means	
"P" document published prior to the international filing date but later than the priority date claimed	

Date of the actual completion of the international search 27 NOVEMBER 1995	Date of mailing of the international search report 03 JAN 1996
---	--

Name and mailing address of the ISA/US Commissioner of Patents and Trademarks Box PCT Washington, D.C. 20231 Facsimile No. (703) 305-3230	Authorized officer <i>Virginia Portner</i> VIRGINIA PORTNER Telephone No. (703) 308-0196
---	--

INTERNATIONAL SEARCH REPORT

International application No.
PCT/US95/12444

C (Continuation). DOCUMENTS CONSIDERED TO BE RELEVANT

Category*	Citation of document, with indication, where appropriate, of the relevant passages	Relevant to claim No.
Y	Analytical Chemistry, Volume 66, number 11, issued 01 June 1994, Gomez et al., "Determination of Binding Constants of Ligands to Proteins by Affinity Capillary Electrophoresis: Comparison for Electroosmotic Flow," pages 1785-1791, especially pages 1785-1786.	1,2,6,17
Y	Nature, Volume 359, issued 22 October 1992, Hahn et al., "Patterns of elevated free calcium and calmodulin activation in living cells," pages 736-738, especially abstract and figures 1-4.	7,11,12,13,14
Y	Neuron, Volume 2, issued March 1990, Kramer, "Patch Cramming: Monitoring Intracellular Messengers in Intact cells with Membrane Patches Containing Detector Ion Channels," pages 335-341, especially pages 335-336,340, column 1, last paragraph.	9,10,15,16, 18-21,25
Y	American Chemical Society, 1991, Volume 63 number 18, Linhares et al, "Use of an On-Column Fracture in Capillary Zone Electrophoresis for Sample Introduction," pages 2078-2080, especially page 2078 and figure 1 on page 2079.	23,24
Y	US, A, 5,278,048 (PARCE ET AL.) 11 January 1994, column 2, lines 7-68 and column 3, lines 1-50, column 8, lines 7-14, example 8.	8,11,14,20,22
Y	Proc. Natl. Acad. Sci. USA, Volume 84, issued April 1987, Sun, "Evoked Release of Acetylcholine From the Growing Embryonic Neuron," pages 2540-2544, especially page 2540 and methods section.	7,10,13,16,
Y	US, A, 5,258,295 (STARR ET AL.),02 November 1993, column 7-8.	1,26
Y	US, A 5,084,150,(KARGER ET AL.) 28 January 1992, column 4, lines 8-68.	1-6
X	US, A, 5,108,568 (VAN ALSTINE) 28 APRIL 1992, Column 6, lines 36-68, column 8, lines 6-39, column 9, lines 1-10	1

INTERNATIONAL SEARCH REPORT

International application No.
PCT/US95/12444

B. FIELDS SEARCHED

Electronic data bases consulted (Name of data base and where practicable terms used):

APS, MEDLINE, DIALOG

capillary electrophoresis, capillary zone electrophoresis, capillary gel electrophoresis, capillary isotachopheresis, affinity
capillary electrophoresis, biosensor, ligand, receptor, cell, oocyte, outlet end, transmembrane voltage, intracellular
calcium, acetylcholine, bradykinin, ATP