



(51) International Patent Classification:

A61M 1/00 (2006.01) A61M 37/00 (2006.01)
A61M 27/00 (2006.01) A61M 31/00 (2006.01)

(21) International Application Number:

PCT/US2009/069279

(22) International Filing Date:

22 December 2009 (22.12.2009)

(25) Filing Language:

English

(26) Publication Language:

English

(30) Priority Data:

61/141,716 31 December 2008 (31.12.2008) US

(71) Applicant (for all designated States except US): **KCI LICENSING, INC.** [US/US]; Legal Department - Intellectual Property, P.O. Box 659508, San Antonio, TX 78265-9508 (US).

(72) Inventor; and

(75) Inventor/Applicant (for US only): **COLLINS, Barbara, A.** [US/US]; 20525 Wind Springs, San Antonio, TX 78258 (US).

(74) Agents: **WELCH, Gerald, T.** et al.; Sonnenschein, Nath & Rosenthal LLP, P.O. Box 061080, Wacker Drive Station, Willis Tower, Chicago, IL 60606 (US).

(81) Designated States (unless otherwise indicated, for every kind of national protection available): AE, AG, AL, AM, AO, AT, AU, AZ, BA, BB, BG, BH, BR, BW, BY, BZ, CA, CH, CL, CN, CO, CR, CU, CZ, DE, DK, DM, DO, DZ, EC, EE, EG, ES, FI, GB, GD, GE, GH, GM, GT, HN, HR, HU, ID, IL, IN, IS, JP, KE, KG, KM, KN, KP, KR, KZ, LA, LC, LK, LR, LS, LT, LU, LY, MA, MD, ME, MG, MK, MN, MW, MX, MY, MZ, NA, NG, NI, NO, NZ, OM, PE, PG, PH, PL, PT, RO, RS, RU, SC, SD, SE, SG, SK, SL, SM, ST, SV, SY, TJ, TM, TN, TR, TT, TZ, UA, UG, US, UZ, VC, VN, ZA, ZM, ZW.

(84) Designated States (unless otherwise indicated, for every kind of regional protection available): ARIPO (BW, GH, GM, KE, LS, MW, MZ, NA, SD, SL, SZ, TZ, UG, ZM, ZW), Eurasian (AM, AZ, BY, KG, KZ, MD, RU, TJ, TM), European (AT, BE, BG, CH, CY, CZ, DE, DK, EE, ES, FI, FR, GB, GR, HR, HU, IE, IS, IT, LT, LU, LV, MC, MK, MT, NL, NO, PL, PT, RO, SE, SI, SK, SM, TR), OAPI (BF, BJ, CF, CG, CI, CM, GA, GN, GQ, GW, ML, MR, NE, SN, TD, TG).

Published:

— without international search report and to be republished upon receipt of that report (Rule 48.2(g))

(54) Title: SLEEVES, MANIFOLDS, SYSTEMS, AND METHODS FOR APPLYING REDUCED PRESSURE TO A SUBCUTANEOUS TISSUE SITE

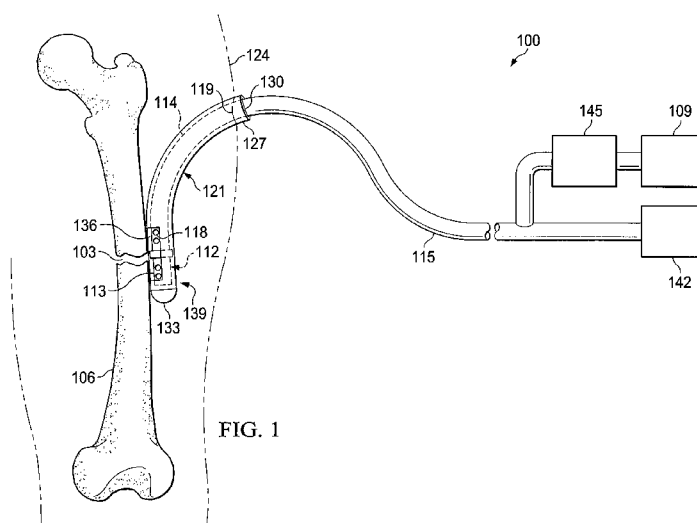

FIG. 1

(57) Abstract: The illustrative embodiments described herein are directed to apparatuses, systems, and methods for applying reduced pressure to subcutaneous tissue site. In one illustrative embodiment, the apparatus includes a sleeve adapted for placement at a subcutaneous tissue site. The sleeve is further adapted to receive a manifold. The sleeve may also have an opening operable to transfer reduced pressure from the manifold to the subcutaneous tissue site. In one embodiment, the apparatus may also include a manifold that is insertable into the sleeve. The manifold may include at least one aperture, and may be operable to deliver reduced pressure to the subcutaneous tissue site via at least one aperture.



SLEEVES, MANIFOLDS, SYSTEMS, AND METHODS FOR APPLYING REDUCED PRESSURE TO A SUBCUTANEOUS TISSUE SITE

CROSS-REFERENCE TO RELATED APPLICATIONS

5

[0001] This application claims the benefit of U.S. Provisional Application No. 61/141,716, filed December 31, 2008, which is hereby incorporated by reference.

BACKGROUND OF THE INVENTION

10

1. Field of the Invention

[0002] The present application relates generally to medical treatment systems, and more particularly, to a reduced pressure treatment system and method for applying reduced pressure to a tissue site.

15

2. Description of Related Art

[0003] Clinical studies and practice have shown that providing a reduced pressure in proximity to a tissue site augments and accelerates the growth of new tissue at the tissue site. The applications of this phenomenon are numerous, but one particular application of reduced pressure involves treating wounds. This treatment (frequently referred to in the medical community as “negative pressure wound therapy,” “reduced pressure therapy,” or “vacuum therapy”) provides a number of benefits, including migration of epithelial and subcutaneous tissues, improved blood flow, and micro-deformation of tissue at the wound site. Together these benefits result in increased development of granulation tissue and faster healing times. Typically, reduced pressure is applied by a reduced pressure source to tissue through a porous pad or other manifold device. In many instances, wound exudate and other liquids from the tissue site are collected within a canister to prevent the liquids from reaching the reduced pressure source.

25

SUMMARY

5 [0004] The problems presented by existing reduced pressure systems are solved by the systems and methods of the illustrative embodiments described herein. In one embodiment, a system for applying reduced pressure to a subcutaneous tissue site is provided. The system includes a sleeve, which comprises a lumen, adapted for placement at a subcutaneous tissue site. The sleeve includes an opening. The system further includes a manifold sized and shaped to be inserted into the lumen of the sleeve. The manifold includes at least one aperture and is operable to deliver reduced pressure to the subcutaneous tissue site through the at least one aperture and the opening.

10 [0005] In another embodiment, an apparatus for applying reduced pressure to a subcutaneous tissue site includes a manifold having a distal end and a proximal end and a sleeve having a distal end and proximal end. The sleeve is sized and shaped for placement at the subcutaneous tissue site. The sleeve has an interior portion for receiving the manifold. 15 The sleeve is formed with an opening operable to transfer reduced pressure from the manifold to the subcutaneous tissue site. The distal end of the manifold is sized and shaped to be inserted into the interior portion of the sleeve. The manifold is formed with at least one aperture and is operable to deliver reduced pressure to the subcutaneous tissue site through the at least one aperture.

20 [0006] In still another embodiment, a method for applying reduced pressure to a subcutaneous tissue site includes inserting a sleeve at the subcutaneous tissue site such that an opening on the sleeve is adjacent the subcutaneous tissue site. A manifold is inserted into the sleeve, the manifold including at least one aperture. Reduced pressure is supplied to the subcutaneous tissue site via the at least one aperture and the opening.

25 [0007] In yet another embodiment, a method of manufacturing an apparatus for applying reduced pressure to a subcutaneous tissue site is provided. The method includes forming a sleeve adapted for placement at the subcutaneous tissue site. The sleeve is further adapted to receive a manifold and includes an opening operable to transfer reduced pressure from the manifold to the subcutaneous tissue site.

30 [0008] Other objects, features, and advantages of the illustrative embodiments will become apparent with reference to the drawings and detailed description that follow.

BRIEF DESCRIPTION OF THE DRAWINGS

[0009] Figure 1 illustrates a schematic of a reduced-pressure treatment system for applying reduced pressure to a subcutaneous tissue site according to an illustrative embodiment;

[0010] Figure 2 illustrates a side view of an apparatus for applying reduced pressure to a subcutaneous tissue site according to an illustrative embodiment;

[0011] Figure 3 illustrates a perspective view of a distal portion of the apparatus of Figure 2 with a portion of the apparatus shown in hidden lines;

[0012] Figure 4 illustrates a perspective view of the apparatus of Figure 2;

[0013] Figure 5 illustrates a side view of a manifold and end cap according to an illustrative embodiment;

[0014] Figure 6 illustrates a cross-sectional front view of the end cap of Figure 5 taken at 6-6;

[0015] Figure 7 illustrates a cross-sectional front view of the end cap of Figure 5 taken at 7-7;

[0016] Figure 8 illustrates a cross-sectional view of a portion of the end cap of Figure 6 taken at 8-8; and

[0017] Figure 9 illustrates a schematic of a reduced-pressure treatment system for applying reduced pressure to a tissue site in an abdominal cavity.

DETAILED DESCRIPTION OF ILLUSTRATIVE EMBODIMENTS

[0018] In the following detailed description of several illustrative embodiments, reference is made to the accompanying drawings that form a part hereof, and in which is shown by way of illustration specific preferred embodiments in which the invention may be practiced. These embodiments are described in sufficient detail to enable those skilled in the art to practice the invention, and it is understood that other embodiments may be utilized and that logical structural, mechanical, electrical, and chemical changes may be made without departing from the spirit or scope of the invention. To avoid detail not necessary to enable those skilled in the art to practice the embodiments described herein, the description may omit certain information known to those skilled in the art. The following detailed description is, therefore, not to be taken in a limiting sense, and the scope of the illustrative embodiments are defined only by the appended claims.

[0019] The term “reduced pressure” as used herein generally refers to a pressure less than the ambient pressure at a tissue site that is being subjected to treatment. In most cases, this reduced pressure will be less than the atmospheric pressure at which the patient is located. Alternatively, the reduced pressure may be less than a hydrostatic pressure associated with tissue at the tissue site. Although the terms “vacuum” and “negative pressure” may be used to describe the pressure applied to the tissue site, the actual pressure reduction applied to the tissue site may be significantly less than the pressure reduction normally associated with a complete vacuum. Reduced pressure may initially generate fluid flow in the area of the tissue site. As the hydrostatic pressure around the tissue site approaches the desired reduced pressure, the flow may subside, and the reduced pressure is then maintained. Unless otherwise indicated, values of pressure stated herein are gauge pressures. Similarly, references to increases in reduced pressure typically refer to a decrease in absolute pressure, while decreases in reduced pressure typically refer to an increase in absolute pressure.

[0020] Referring to Figure 1, a reduced-pressure treatment system 100, which applies reduced pressure to a tissue site 103, is shown according to an illustrative embodiment. In the embodiment illustrated in Figure 1, the tissue site 103 is a bone tissue site. In particular, the tissue site 103 is a fracture on bone 106, which in the example illustrated is a femur. It is believed that reduced pressure at tissue site 103 provides a number of benefits. When used to promote bone tissue growth, reduced-pressure treatment can increase the rate of healing

associated with a fracture, a non-union, a void, or other bone defects. Reduced-pressure treatment may also be used to improve recovery from osteomyelitis. The treatment may further be used to increase localized bone densities in patients suffering from osteoporosis. Finally, reduced-pressure treatment may be used to speed and improve osseointegration of orthopedic implants, such as hip implants, knee implants, and fixation devices.

[0021] While the tissue site 103 is bone tissue, the term “tissue site” as used herein may refer to a wound or defect located on or within any tissue, including but not limited to, bone tissue, adipose tissue, muscle tissue, neural tissue, dermal tissue, vascular tissue, connective tissue, cartilage, tendons, or ligaments. The term “tissue site” may further refer to areas of any tissue that are not necessarily wounded or defective, but are instead areas in which it is desired to add or promote the growth of additional tissue. For example, reduced pressure tissue treatment may be used in certain tissue areas to grow additional tissue that may be harvested and transplanted to another tissue location.

[0022] Referring to Figure 1, a reduced pressure treatment system 100 includes a reduced pressure source 109 and a manifold 112 that is positioned at the tissue site 103. The reduced-pressure source 109 provides reduced pressure to tissue site 103 through the manifold 112. The manifold 112 may include a passageway (not illustrated in Figure 1) for administering reduced pressure and removing or supplying fluids to the tissue site 103. The passageway may extend from a distal end 113 of the manifold 112 to a proximal end 114. The manifold 112 receives the reduced pressure from the reduced-pressure source 109 through a delivery conduit 115, which is in fluid communication with the manifold 112 and delivers reduced pressure to the manifold 112 during treatment. The manifold 112 may include at least one aperture, such as apertures 118, and may deliver reduced pressure to the tissue site 103 via the apertures 118.

[0023] In one illustrative embodiment, the manifold 112 may be inserted into a sleeve 121 to provide reduced pressure treatment to the tissue site 103. The sleeve 121, which may be a lumen member, may extend from the tissue site 103, through the patient’s skin, and to a location external to the patient 124. The proximal end 127 of the sleeve 121, which has an opening 130 into which the manifold 112 may be inserted, may protrude from the patient 124 when the sleeve 121 is placed at the tissue site 103. Exposing the proximal end 127 of the sleeve 121 in this manner facilitates access to the sleeve 121 and the insertion of the manifold 112 into the sleeve 121. The manifold 112 has a longitudinal length L1, the sleeve has a

longitudinal length L2, and a distance from the tissue site to a location external to the patient is L3. In one embodiment, $L1 > L2 > L3$. In another embodiment, the proximal end 127 of the sleeve 121 may be subcutaneously disposed in the patient 124, i.e., $L2 < L3$. The sleeve 121 may be disposed at the tissue site 103 of a patient 124 in a variety of different spatial orientations, including the flexed orientation shown in Figure 1. The sleeve 121 may be releasably secured to a patient 124 to hold the sleeve 121 in a fixed position with respect to the tissue site 103 or may be unsecured. In one embodiment, the sleeve 121 may be sutured into place or adhered using a medical epoxy, medical tape, or other means. The proximal end 127 may include a flange (not shown) to prevent the proximal end 127 from entering the patient 124. Moreover, the flange might be put in a position abutting an external portion of the patient 124 and adhered using epoxy, medical tape, sutures, etc.

[0024] The sleeve 121 is capable of slidably receiving the manifold 112. The manifold 112 may be inserted into the opening 130 and moved toward the distal end 133 of the sleeve 121. The manifold 112 may be placed adjacent an opening 136 in sleeve 121. The opening 136 may be located at a distal portion 139 of the sleeve 121, may run the length of the sleeve 121, or may take any shape or size. The manifold 112 may include visual indicia (see by analogy 691 in Fig. 9) to help gauge the extent to which manifold 112 has been inserted into an interior portion of the sleeve 121. An exterior portion of the manifold 112 or the interior portion of the sleeve 121 or both may include ribs to provide tactile feedback to the healthcare provider regarding the relative position of the sleeve 121 and the manifold 111. The manifold 112 is capable of delivering reduced pressure from the reduced-pressure source 109 to the tissue site 103 via the opening 136 in the sleeve 121.

[0025] In use, it may be desirable to releasably secure the manifold 112 to the sleeve 121. An interference fit or groove lock may be used as described further below. Alternatively, the manifold 112 may include a longitudinal ridge member (not shown) that is positioned along the length (or a portion of the length) of the manifold 112 and that mates with a longitudinal groove (not shown) on the interior portion of the sleeve 121. Alternatively, the groove may be on the manifold 112 and the ridge member on the sleeve 121. This approach to securing the manifold 112 and sleeve 121 may further help assure that the manifold 112 assumes a proper position with respect to opening 136 and ultimately tissue site 103.

[0026] The manifold 112 may be both insertable and removable from the sleeve 121 while the sleeve 121 remains at the tissue site 103. During use, a pneumatic seal may be

formed about the manifold 112 and sleeve 121 proximate an opening 119 in the patient 124, e.g., an opening in the patient's skin. The pneumatic seal may be formed using a drape material, medical tape, a hydrocolloid, or other sealing members.

5 [0027] The manifold 112 may be moved out of the sleeve 121 at any time. By allowing the manifold 112 to be inserted and removed from the sleeve 121 while the sleeve remains at the tissue site 103, the system 100 facilitates effective reduced-pressure treatment of the tissue site 103. For example, in the event that the manifold 112 becomes clogged, such as by fibrin, tissue, or any other bodily substance, the manifold 112 may be removed from the sleeve 121 and either cleaned or replaced with another manifold that can be inserted into the sleeve 121. Indeed, the manifold 112 may be removed or re-inserted for any reason, such as to 10 visually monitor the integrity of the manifold 112 or to facilitate the movement of the patient 124 by disconnecting the patient 124 from the reduced-pressure source 109. Further, the insertion and removal of the manifold 112 may be repeated any number of times while minimizing the disruption of or damage to tissue in and around the tissue site 103 or at the 15 skin.

[0028] In one embodiment, clogging of the manifold 112 may be reduced or prevented by delivering a purging fluid to the manifold 112. In this embodiment, a fluid source 142 may supply a purging fluid. The delivery conduit 115 may deliver the fluid to the manifold 112. The fluid may be a liquid or a gas, such as air, and may purge any blockages in the manifold 20 112. These purged substances, which may include fibrin, tissue, or any other bodily substance, are drawn out of the manifold 112 and toward the reduced-pressure source 109 using reduced pressure from the reduced-pressure source 109. These substances may be received by a container 145. In another embodiment, the fluid source 142 may also supply antibacterial agents, antiviral agents, cell-growth promotion agents, irrigation fluids, or other 25 chemically active agents to the tissue site 103.

[0029] In one embodiment, a method for applying reduced pressure to the tissue site 103 includes inserting the sleeve 121 at the tissue site 103 such that the opening 136 on the sleeve 121 is adjacent the tissue site 103. The method may also include inserting the manifold 112, which includes apertures 118, into the sleeve 121. Reduced pressure is supplied to the 30 tissue site 103 via the apertures 118 and the opening 136. The method may further include removing the manifold 112 from the sleeve 121. In this embodiment, the sleeve 121 may remain at the tissue site 103, and the manifold 112, or any other manifold, may be inserted or

re-inserted into the sleeve 121. The sleeve 121 may also be removed from the tissue site 103 at any time, with or without the manifold 112 being positioned in the sleeve 121.

5 [0030] In one embodiment, a method of manufacturing an apparatus for applying reduced pressure to the tissue site 103 includes forming the sleeve 121. The method may also include forming the manifold 112.

10 [0031] Referring to Figures 2-4, an apparatus 201 for applying reduced pressure to a subcutaneous tissue site is shown in accordance with an illustrative embodiment. In particular, Figures 2-4 show a manifold 212 and a sleeve 221, which are similar to the manifold 112 and the sleeve 121 in Figure 1, respectively. The sleeve 221 and the manifold 212 may have the same lateral cross-sectional shape. In Figures 2-4, the sleeve 221 and the manifold 212 have a circular lateral cross-section. The sleeve 221 or the manifold 212 may have other lateral cross-sectional shapes, such as an ellipse, a polygon, an irregular shape, or a customized shape.

15 [0032] The width 248 of the sleeve 221 is preferably larger than the width 251 of the manifold 212. However, the width 251 of the manifold 212 is not required to be constant along the entire length of the manifold 212. The width 251 of the manifold 212 may instead be varied along its length relative to the width 248 of the sleeve 221 to increase or decrease the amount of space between the manifold 212 and the sleeve 221.

20 [0033] The sleeve 221 or the manifold 212 may be made from a variety of biocompatible materials, including silicone. The sleeve 221 may be flexible such that the sleeve 221 is bendable when inserted or disposed subcutaneously. In one embodiment, the sleeve 221 is composed of a more flexible material than the manifold 212. The rigidity of the manifold 212 may help to prevent the collapse of the manifold 212 when exposed to reduced pressure.

25 [0034] The opening 236 of the sleeve 221, which is functionally analogous to the opening 136 in Figure 1, may be located on a wall 257, or side wall, of the sleeve 221. The opening 236 is positioned at or near the most distal portion 233 of sleeve 221 and expands along a length of the sleeve 221. The opening 236 is capable of transferring reduced pressure from the manifold 212 to a tissue site. In one embodiment, the opening 236 may extend along substantially the entire length 260 of the sleeve 221.

30 [0035] The opening 236 is shown to have a substantially rectangular shape. However, the opening 236 may have any shape, including a circular, elliptical, polygonal, irregular, or customized shape. In the example in which the opening 236 has a customized shape, the

opening 236 may be created based on the particular implementation or tissue site being treated by the apparatus 201. In addition, sleeve 221 may have two or more openings 236. The two or more openings 236 may face the same or different directions. For example, two openings 236 may be located on opposite sides of the wall 257. In another example, the two openings 236 may be located on the same side of the wall 257, and may be aligned along the length 260 of the sleeve 221. The size, shape, and number of openings 236 may depend on the particular tissue site and type of treatment being implemented.

[0036] Manifold 212 includes a plurality of apertures 218 that partially or fully surround the manifold 212. In the example in which the apertures 218 fully surround the manifold 212 and the manifold 212 is substantially cylindrical, the apertures 218 may be located around the circumference of the manifold 212. In the example in which the apertures 218 partially surround the manifold 212, each of the apertures 218 may be disposed to substantially face toward the opening 236 when the manifold 212 is inserted in the sleeve 221.

[0037] The manifold 212 may also include a flange 263, which may partially or fully surround the manifold 212. An outer edge 266 of the flange 263 may at least partially abut an inner surface 269 of the sleeve 221 when the manifold 212 is inserted in the sleeve 221. Also, the outer edge 266 of the flange 263 may be slidable along the inner surface 269 of the sleeve 221 when the manifold 212 is inserted into the sleeve in the direction of arrow 272 or removed in the direction of arrow 275. The flange 263 may be disposed anywhere along the manifold 212, including the end 278 of the manifold 212. Any number of flanges 263, such as two or more flanges 263 may be included.

[0038] The flange 263 is capable of moving a substance, such as a bodily substance or fluid, toward the proximal end 227 of the sleeve 221 when the manifold 212 is removed from the sleeve 221 as suggested by arrow 275 in Figure 2. In this embodiment, the removal of the manifold 212 helps to clear the sleeve 221, including the distal end 239 of the sleeve 221, of debris, such as exudate, tissue, or any other substance.

[0039] The width 281, or outer diameter, of the flange 263 may be larger than the width 283 of the opening 236. In this embodiment, the flange 263 may help to prevent the manifold 212 from exiting the sleeve 221 through the opening 236, especially when the manifold 212 is being inserted into the sleeve 221. In an alternative embodiment (not shown), the interior of the sleeve 221 may include a blocking member designed to engage flange 263 and stop further insertion of manifold 212 into sleeve 221. Alternatively, the manifold 212

may include a surface feature on a proximal portion that prevents further advancement of the manifold 212 into sleeve 221.

[0040] In one embodiment, the flange 263 includes at least one hole, such as holes 285. The holes 285 allow fluid communication between the space 287 on the distal side of the flange 263 and the space 289 on the proximal side of the flange 263. The flange 263 may include any number of holes 285, and the holes 285 may have any shape. In one embodiment, the flange 263 has no holes 285. In another embodiment, the holes 285 may have one-way valves in the holes 285 that allow fluid to be pulled out of the sleeve 221 when the manifold 212 is removed, but avoid pushing air or other fluids when the manifold 212 is moved into the sleeve 221 (i.e., the valves allow fluid flow through the valves in the direction of arrow 275, but prevent flow in the direction of arrow 272).

[0041] Although the flange 263 is shown in Figure 3 as being positioned along the length of opening 236 when the manifold 212 is fully inserted within the sleeve 221, the flange 263 could instead be located distal to the opening 236 when the manifold 212 is fully inserted. In this particular embodiment, the positioning of the flange 263 distal to the opening 236 may allow the flange 263 to better remove all bodily debris and substances (when the manifold is removed) that enter the sleeve 221 through the opening 236.

[0042] The sleeve 221 includes an end cap 291 that is coupled to a distal end 292 of the sleeve 221. As used herein, the term “coupled” includes coupling via a separate object, and also includes direct coupling. In the case of direct coupling, the two coupled objects touch each other in some way. The term “coupled” also encompasses two or more components that are continuous with one another by virtue of each of the components being formed from the same piece of material. Also, the term “coupled” includes chemical coupling, such as via a chemical bond. The term “coupled” may also include mechanical, thermal, or electrical coupling. “Coupled” may also mean fixedly coupled or removably coupled.

[0043] The end cap 291 may prevent fluid and reduced pressure from entering or exiting the sleeve 221 at the distal end 292 of the sleeve 221. The end cap 291 may have any shape, including a rounded or dome shape. In the example in which the end cap 291 has a rounded or dome shape, the shape of the end cap 291 better facilitates the subcutaneous insertion of the sleeve 221. Also, the space 293 inside the end cap 291 may be either hollow or solid. In another embodiment, the sleeve 221 does not include the end cap 291.

[0044] Referring more specifically to Figure 4, a delivery conduit 215, which is functionally analogous to the delivery conduit 115 in Figure 1, may deliver reduced pressure or fluid to the manifold 212. In one embodiment, the delivery conduit 215 may include two or more lumens, such as lumens 293 and 294. In one example, the lumen 293 delivers reduced pressure to the manifold 212, and the lumen 294 delivers a fluid to the manifold 212. The delivery conduit 215 is fluidly coupled to the manifold 212.

[0045] Referring to Figures 5-8, a manifold 512, which is similar to the manifold 112 in Figure 1, and an end cap 591, which is similar to the end cap 291 in Figures 2-4, are shown in an exploded view. The sleeve to which end cap 591 is coupled is not illustrated in Figure 5 for purposes of clarity. The end cap 591 includes a securing wall 595 on a sleeve-facing side 596 of the end cap 591. In one embodiment, the securing wall 595 receives the distal end 578 of the manifold 512 such that the securing wall 595 at least partially surrounds the distal end 578 of the manifold 512 and may form an interference fit. Alternatively, the distal end 578 of the manifold may receive and surround the securing wall 595 and may form an interference fit. The securing wall 595 may stabilize, secure, or prevent relative movement, e.g., lateral or longitudinal movement, of the manifold 512 and sleeve 521 when the manifold 512 is inserted into the sleeve 521. The space 502 around the securing wall 595 may be hollow or solid. The end cap 591 may be dome-shaped as shown or may be cylindrical, or may take any other shape.

[0046] In one embodiment, the securing wall 595 may include at least one groove, such as groove 597, and the manifold 512 may include at least one projection, such as projection 598, at or near the distal end 578 of the manifold 512. The projection 598 radially extends from the manifold 512. When the distal end 578 is inserted into the securing wall 595, the groove 597 slidably receives the projection 598. By inserting the projection 598 into the groove 597, the manifold 512 is substantially prevented from rotational movement with respect to with respect to the manifold 512. When the groove 597 slidably receives the projection 598, the manifold is oriented such that the apertures 518 may face the opening (not shown) in the sleeve. By moving the projection 598 into a locking portion 599 of the groove 597, the movement of the manifold 512 out of the sleeve may be hindered or prevented. In another embodiment, the groove 597 does not include the locking portion 599.

[0047] The illustrative embodiments of sleeves and manifolds may be used to provide reduced pressure treatment to one or more tissue sites and at tissue sites located at various

locations within a patient. For example, the system 100 in Figure 1 is shown applied to a tissue site 103 that is a bone. In another illustrative embodiment illustrated in Figure 9, a reduced-pressure treatment system 600 is capable of providing reduced pressure to an abdominal tissue site 603.

5 **[0048]** The system 600 is analogous to system 100, and similar parts to those in Figure 1 have been shown with reference numerals indexed by 500. The tissue site 603 is within an abdominal cavity and in particular within a paracolic gutter 607 of a patient 624. A manifold 612 is inserted into a sleeve 621. The sleeve 621 has a distal end 625 and a proximal end 627. The proximal end 627 of the sleeve 621 has an opening 630 into which the manifold 612 may
10 be inserted. In this embodiment, there is no tissue defect as such, and the manifold 612 is exposed to multiple tissues and tissue sites along an anatomic plane or region, in this case, the abdominal paracolic gutter 607. It should be noted that system 600 is shown applied to one paracolic gutter 607, but may be applied bilaterally to provide reduced pressure treatment to a paracolic gutter 611 on the other side of the patient 624.

15 **[0049]** The sleeve 621 is inserted through an opening in the patient's abdomen and positioned in the paracolic gutter 607. The manifold 612 is inserted into the sleeve 621. The manifold 612 is positioned to have apertures 618 proximate opening 636 and proximate tissue site 603. The proximal end 690 of the manifold 612 is coupled to a delivery conduit 615. The delivery conduit 615 provides reduced pressure from a reduced pressure source 609 to remove
20 fluids (e.g., ascites or exudates) from the tissue site 603, which are then are collected within a container 645. The delivery conduit 615 may also provide a fluid from a fluid source 642. The proximal end 690 of the manifold 612 may include visual indicia 691 to help the healthcare provider gauge the extent to which manifold 612 has been inserted into the sleeve 621. The proximal end 690 may also have a flange or other device to avoid over insertion of
25 the manifold 612 into the sleeve 621.

[0050] The system 600 may be used to provide reduced pressure treatment at the wound site 603 or to only remove fluids, e.g., ascites, from the abdominal cavity. Numerous other tissue sites are also possible.

[0051] It should be apparent from the foregoing that an invention having significant
30 advantages has been provided. While the invention is shown in only a few of its forms, it is not just limited but is susceptible to various changes and modifications without departing from the spirit thereof.

CLAIMS

We claim:

- 5 Claim 1. A system for applying reduced pressure to a subcutaneous tissue site, the system comprising:
a sleeve, which comprises a lumen, adapted for placement at a subcutaneous tissue site and having an opening; and
a manifold sized and shaped to be inserted into the lumen of the sleeve, wherein the manifold includes at least one aperture, and wherein the manifold is operable
10 to deliver reduced pressure to the subcutaneous tissue site through the at least one aperture and the opening.
- Claim 2. The system of claim 1, further comprising:
a reduced-pressure source operable to supply reduced pressure and a delivery
conduit in fluid communication with the manifold, the delivery conduit
15 operable to deliver the reduced pressure to the manifold during treatment.
- Claim 3. The system of claim 1, wherein the tissue site is bone.
- Claim 4. The system of claim 1, wherein the tissue site is within an abdominal cavity.
- Claim 5. The system of claim 1, wherein the tissue site is proximate a paracolic gutter.
- Claim 6. The system of claim 1, wherein the sleeve is formed from a flexible material.
- 20 Claim 7. The system of claim 1, wherein the manifold comprises a fluid passageway for delivering reduced pressure.
- Claim 8. The system of claim 1, wherein the manifold comprises a fluid passageway for delivering reduced pressure and wherein the passageway extends from a distal end of the manifold to a proximal end.
- 25 Claim 9. The system of claim 1, wherein the manifold has a longitudinal length L1, the sleeve has a longitudinal length L2, and wherein $L1 > L2$.

Claim 10. The system of claim 1, wherein the manifold has a longitudinal length L1, the sleeve has a longitudinal length L2, a distance from the subcutaneous tissue site to a location external the patient is L3, and wherein $L1 > L2 > L3$.

Claim 11. The system of claim 2, further comprising:

5 a fluid source operable to supply a fluid, wherein the delivery conduit is further operable to deliver the fluid to the manifold.

Claim 12. An apparatus for applying reduced pressure to a subcutaneous tissue site, the apparatus comprising:

a manifold having a distal end and a proximal end;
10 a sleeve having a distal end and a proximal end, the sleeve sized and shaped for placement at the subcutaneous tissue site, the sleeve having an interior portion for receiving the manifold, the sleeve formed with an opening operable to transfer reduced pressure from the manifold to the subcutaneous tissue site; and
15 wherein the distal end of the manifold is sized and shaped to be inserted into the interior portion of the sleeve, wherein the manifold is formed with at least one aperture, and wherein the manifold is operable to deliver reduced pressure to the subcutaneous tissue site through the at least one aperture.

Claim 13. The apparatus of claim 12, wherein the opening formed on the sleeve is located
20 on a side wall of the sleeve, and wherein the opening extends along a length of the sleeve.

Claim 14. The apparatus of claim 13, wherein the opening is located proximate the distal end of the sleeve.

Claim 15. The apparatus of claim 12, wherein the sleeve is wider than the manifold.

Claim 16. The apparatus of claim 12, wherein the sleeve and the manifold have a same
25 cross-sectional shape.

- Claim 17. The apparatus of claim 12, wherein the manifold further comprises:
a flange at least partially surrounding the manifold, an outer edge of the flange
adapted to at least partially abut the interior portion of the sleeve.
- Claim 18. The apparatus of claim 17, wherein the outer edge of the flange is slidable
5 along an inner surface of the sleeve.
- Claim 19. The apparatus of claim 18, wherein the flange is operable to move a substance
toward a proximal end of the sleeve when the manifold is removed from the sleeve.
- Claim 20. The apparatus of claim 19, wherein the substance is a bodily substance.
- Claim 21. The apparatus of claim 17, wherein the flange includes at least one hole.
- 10 Claim 22. The apparatus of claim 17, wherein the flange is wider than the opening.
- Claim 23. The apparatus of claim 12, further comprising:
an end cap coupled to a distal end of the sleeve.
- Claim 24. The apparatus of claim 23, wherein the end cap has a dome shape.
- Claim 25. The apparatus of claim 23, wherein the end cap includes a securing wall on a
15 sleeve-facing side of the end cap, and wherein the securing wall is adapted to receive the
distal end of the manifold such that the securing wall at least partially surrounds the distal
end of the manifold.
- Claim 26. The apparatus of claim 25, wherein the manifold further comprises at least one
projection on the distal end of the manifold, wherein the at least one projection radially
20 extends from the manifold, and wherein the securing wall includes at least one groove that
slidably receives the at least one projection.
- Claim 27. The apparatus of claim 26, wherein the at least one aperture faces the opening
when the at least one groove slidably receives at least one projection.

- Claim 28. The apparatus of claim 12, wherein at least one of the sleeve and the manifold is composed of silicone.
- Claim 29. The apparatus of claim 12, wherein the sleeve is a flexible sleeve.
- Claim 30. The apparatus of claim 29, wherein the sleeve is made from a more flexible material than the manifold.
- 5
- Claim 31. The apparatus of claim 12, wherein the manifold comprises a fluid passageway for delivering reduced pressure and wherein the passageway extends from a distal end of the manifold to a proximal end.
- Claim 32. The apparatus of claim 12, wherein the manifold has a longitudinal length L1, the sleeve has a longitudinal length L2, and wherein $L1 > L2$.
- 10
- Claim 33. The apparatus of claim 12, wherein the manifold has a longitudinal length L1, the sleeve has a longitudinal length L2, a distance from the tissue site to a location external the patient is L3, and wherein $L1 > L2 > L3$.
- Claim 34. The apparatus of claim 12, wherein the sleeve includes a plurality of openings.
- 15
- Claim 35. The apparatus of claim 12, wherein the sleeve has a substantially cylindrical shape.
- Claim 36. A method for applying reduced pressure to a subcutaneous tissue site, the method comprising:
- 20
- inserting a sleeve at the subcutaneous tissue site such that an opening on the sleeve is adjacent the subcutaneous tissue site;
 - inserting a manifold into the sleeve, wherein the manifold includes at least one aperture; and
 - supplying reduced pressure to the subcutaneous tissue site via the at least one aperture and the opening.
- 25
- Claim 37. The method of claim 36, further comprising:
removing the manifold from the sleeve.

- Claim 38. The method of claim 37, wherein the manifold includes a flange at least partially surrounding the manifold, and wherein removing the manifold from the sleeve includes moving a substance toward a proximal end of the sleeve using the flange.
- Claim 39. The method of claim 36, wherein the sleeve has a proximal end and a distal end and further comprising the step of forming a pneumatic seal about the proximal end of the sleeve and the patient.
- Claim 40. The method of claim 36, wherein the sleeve has a longitudinal groove and the manifold has a longitudinal ridge sized and shaped to slideably mate with the longitudinal groove, and wherein the step of inserting a manifold comprises placing the longitudinal ridge into the longitudinal groove and sliding the manifold into the sleeve.
- Claim 41. The method of claim 36, wherein the manifold comprises a flange and wherein the sleeve is sized and shaped to stop the flange once the manifold has been inserted into the sleeve a predetermined distance.
- Claim 42. The method of claim 36, wherein the manifold comprises a fluid passageway for delivering reduced pressure, wherein the passageway extends from a distal end of the manifold to a proximal end.
- Claim 43. The method of claim 36, wherein the manifold has a longitudinal length $L1$, the sleeve has a longitudinal length $L2$, and wherein $L1 > L2$.
- Claim 44. The method of claim 36, wherein the manifold has a longitudinal length $L1$, the sleeve has a longitudinal length $L2$, a distance from the tissue site to a location external to the patient is $L3$, and wherein $L1 > L2 > L3$.
- Claim 45. The method of claim 36, wherein the tissue site is bone.
- Claim 46. The method of claim 36, wherein the subcutaneous tissue site is within an abdominal cavity.
- Claim 47. The method of claim 36, wherein the subcutaneous tissue site is proximate a paracolic gutter.

Claim 48. A method of manufacturing an apparatus for applying reduced pressure to a subcutaneous tissue site, the method comprising:

5 forming a sleeve adapted for placement at the subcutaneous tissue site and further adapted to receive a manifold, the sleeve having an opening operable to transfer reduced pressure from the manifold to the subcutaneous tissue site.

Claim 49. The method of claim 48, further comprising:

10 forming the manifold, wherein the manifold is insertable into the sleeve, wherein the manifold includes at least one aperture, and wherein the manifold is operable to deliver reduced pressure to the subcutaneous tissue site via at least one aperture.

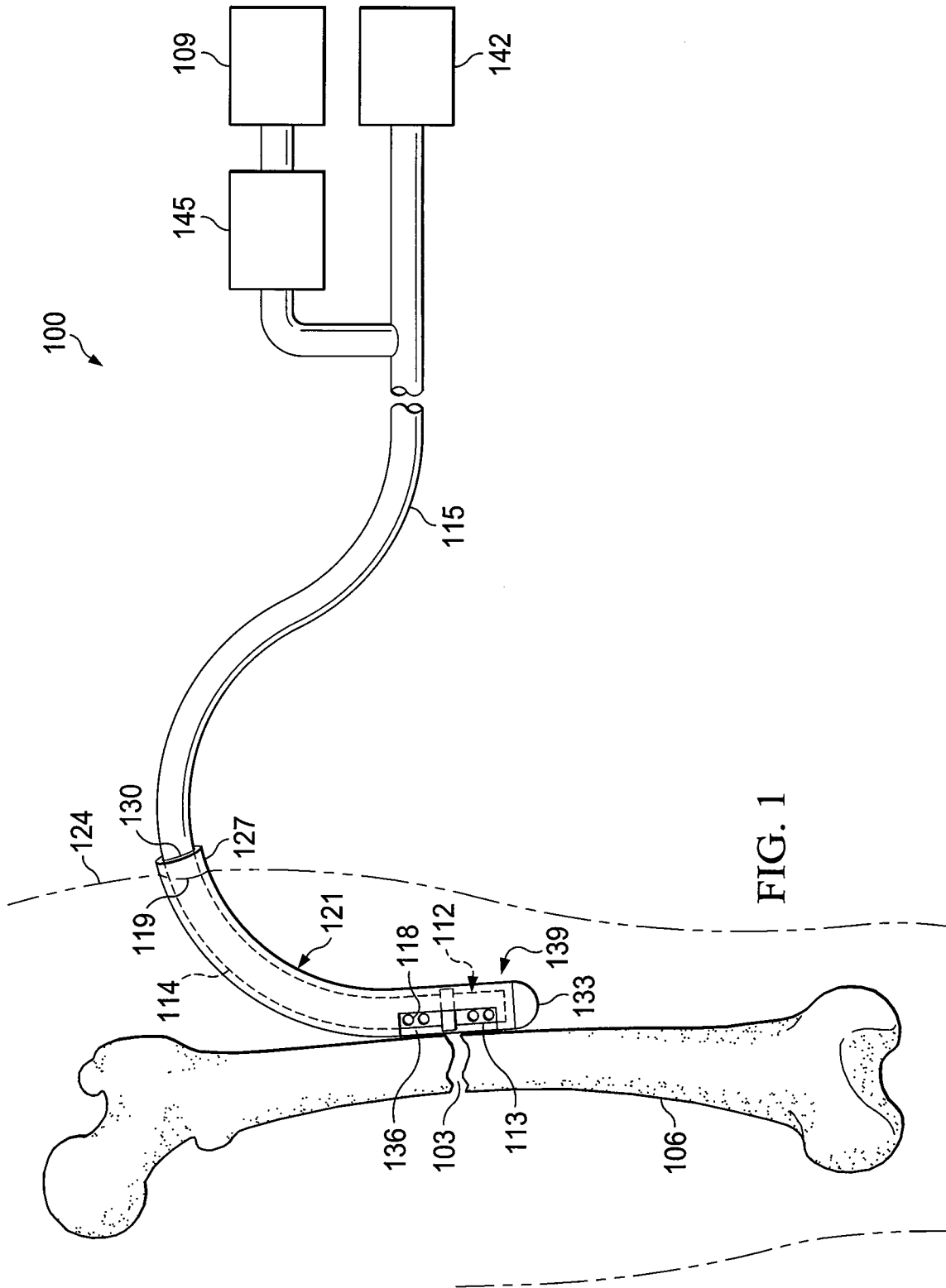
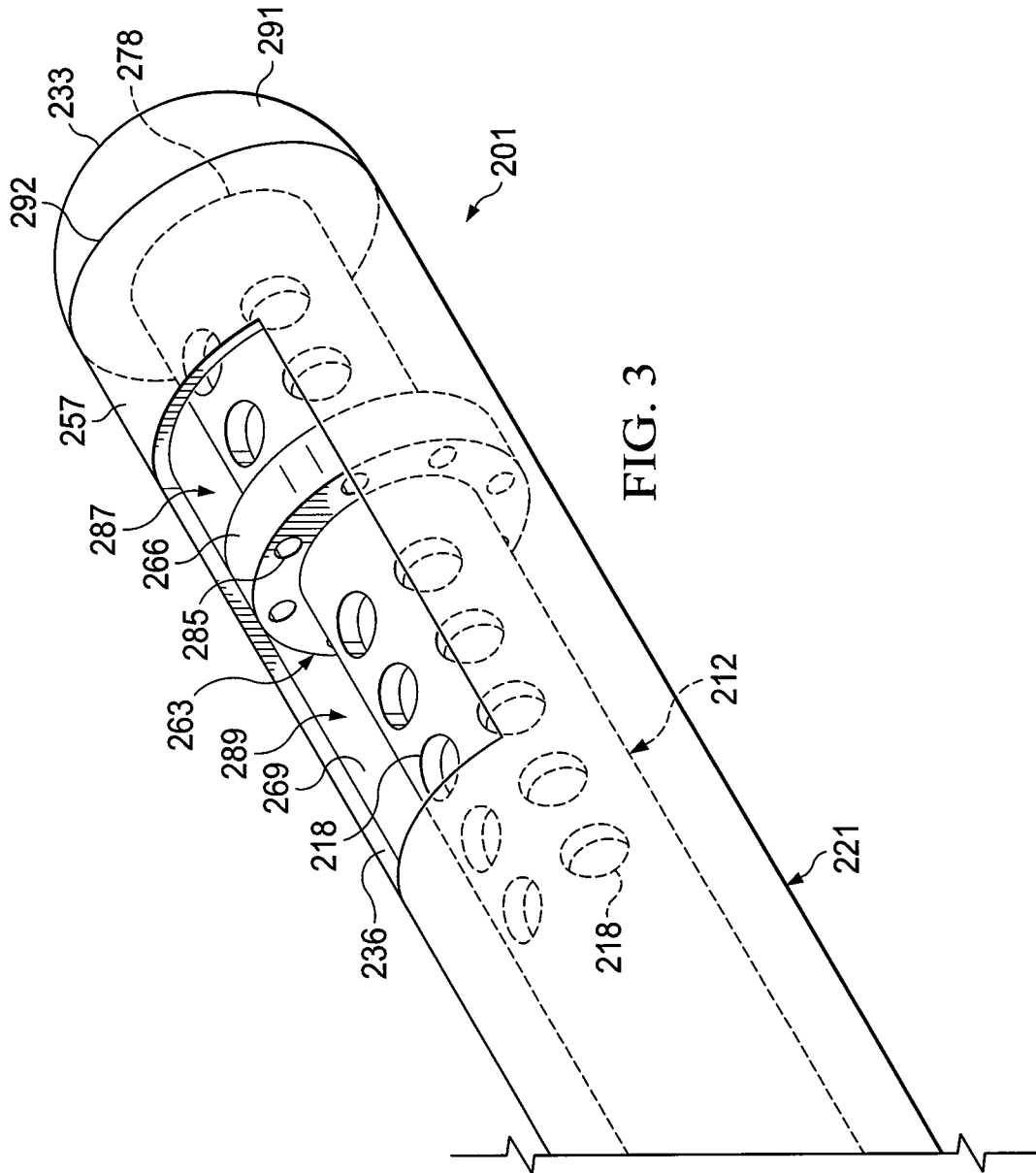

FIG. 1



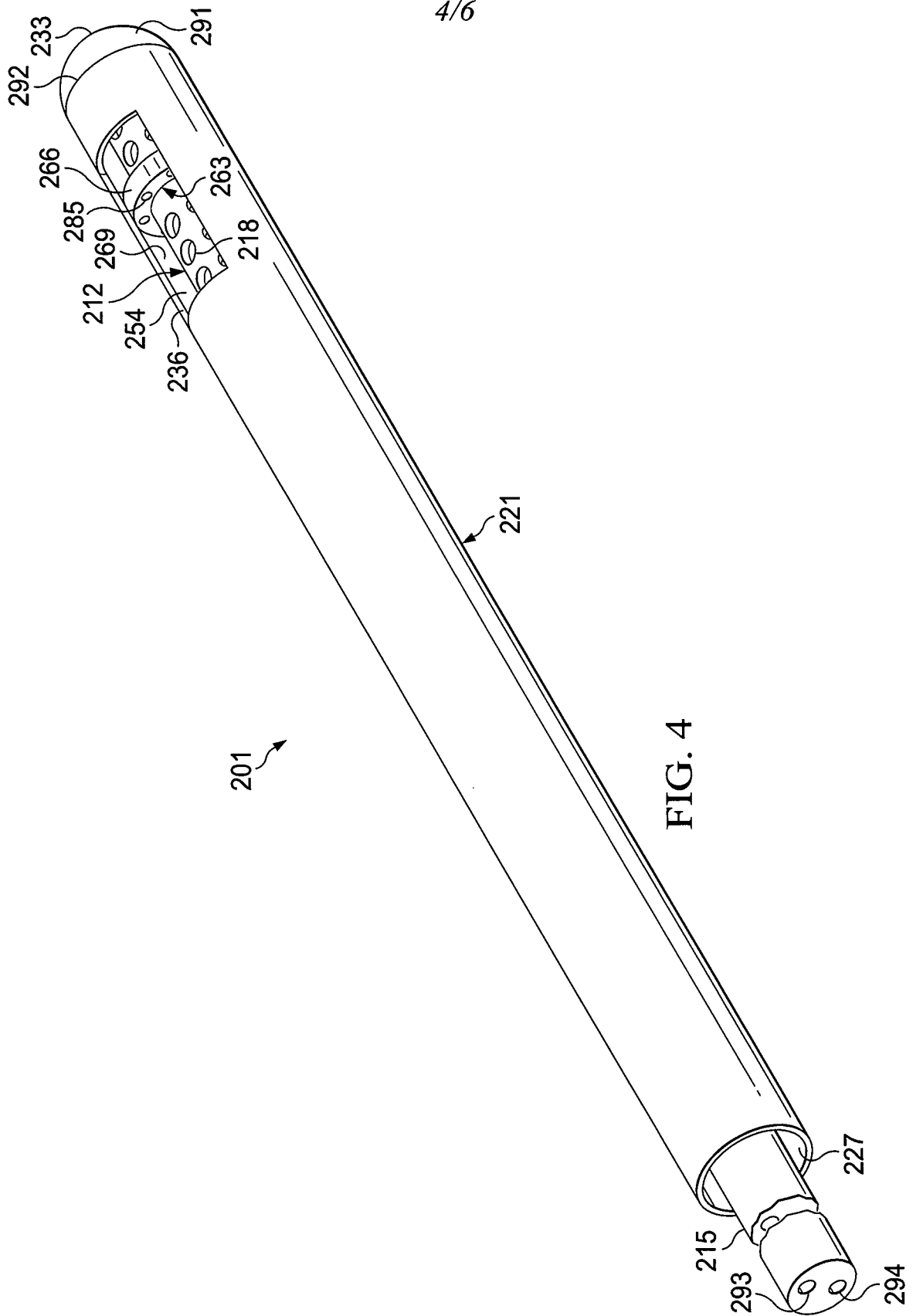

FIG. 4

5/6

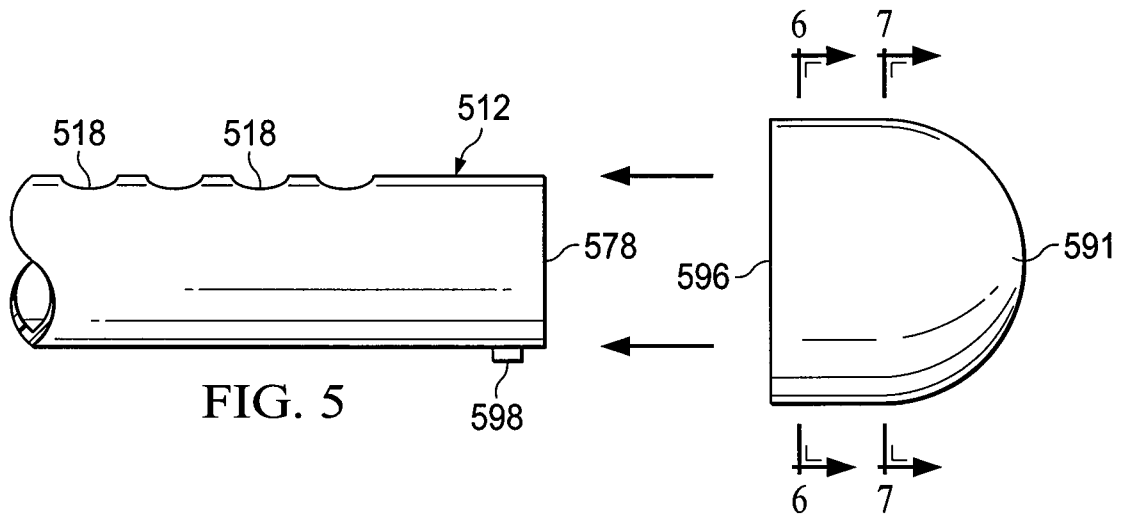

FIG. 5

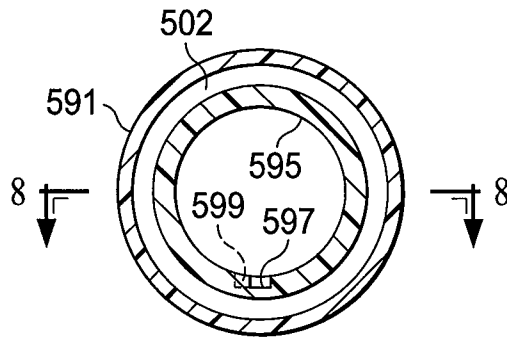

FIG. 6

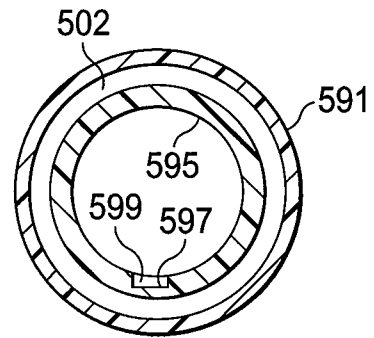

FIG. 7

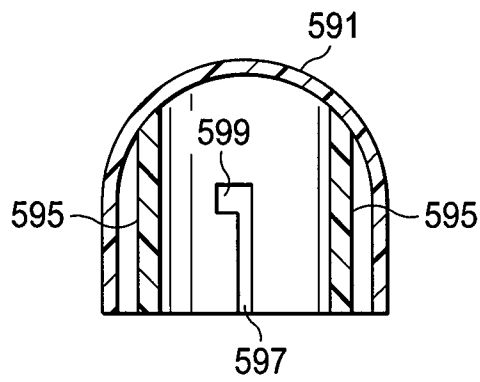

FIG. 8

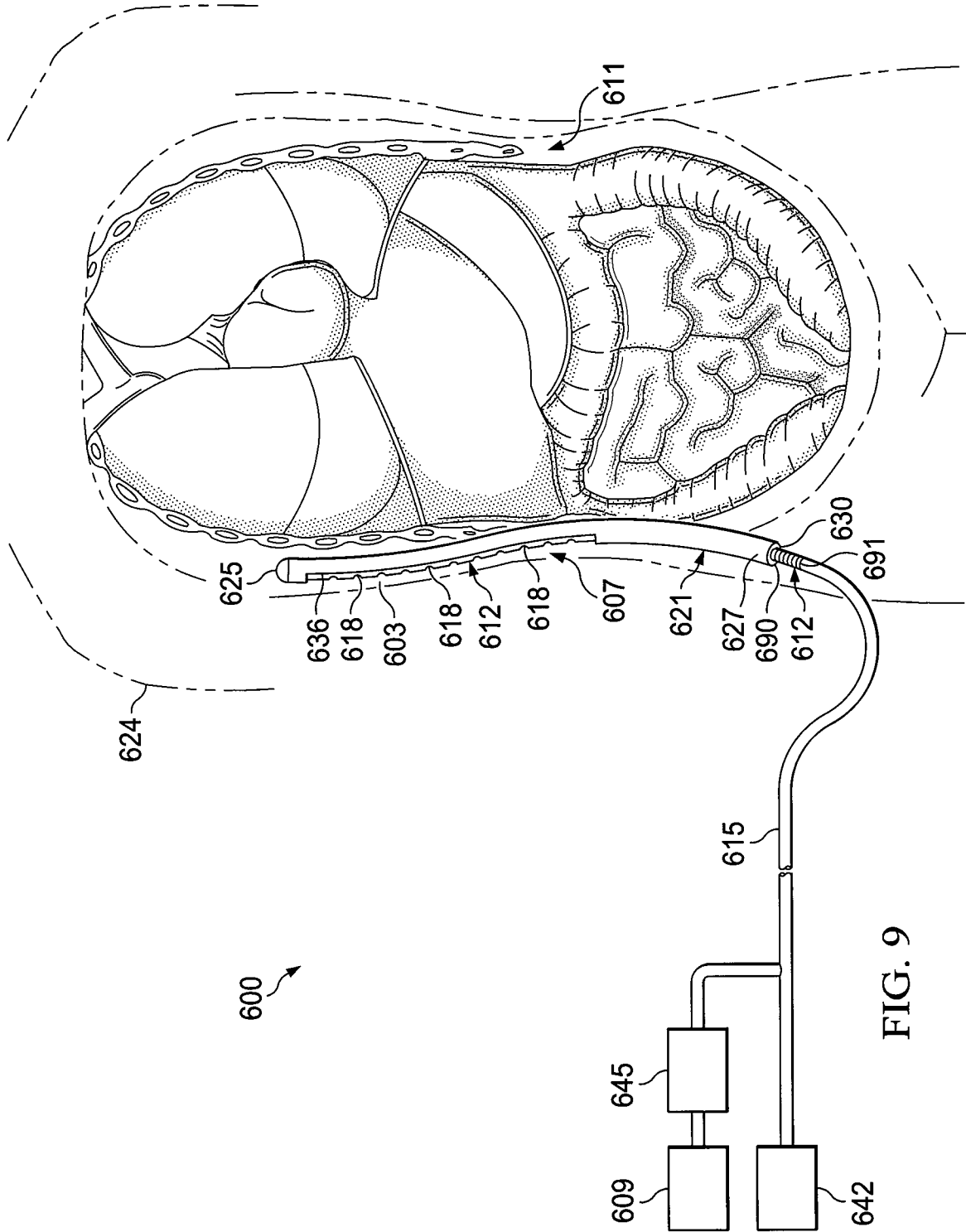

FIG. 9