

Nov. 18, 1924.

1,516,276

A. J. HAUSKINS

CARBURETOR

Filed Sept. 17, 1923

3 Sheets-Sheet 1

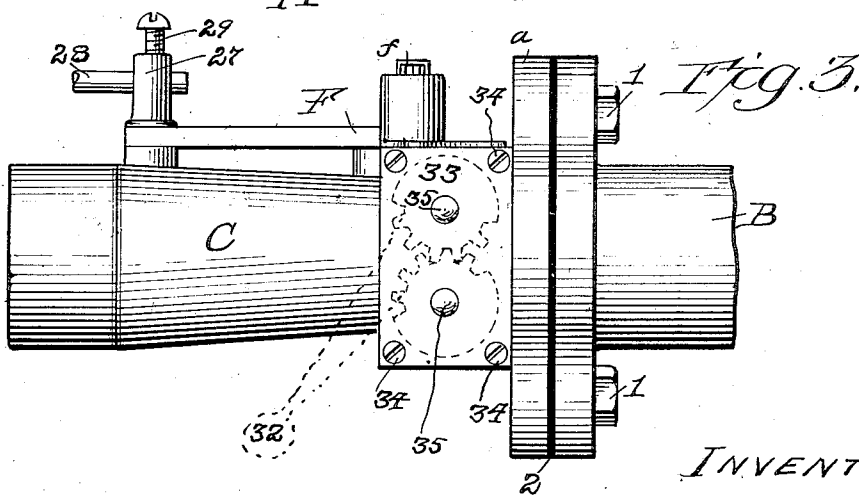
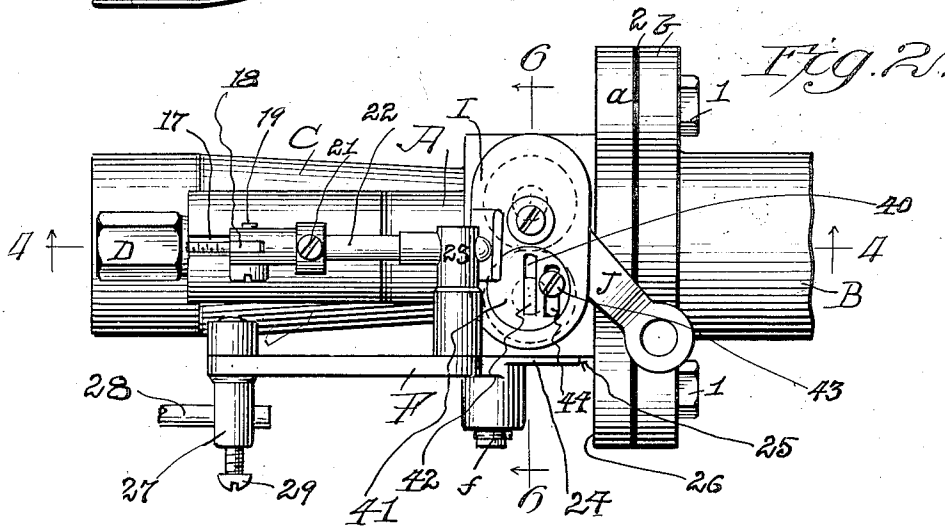
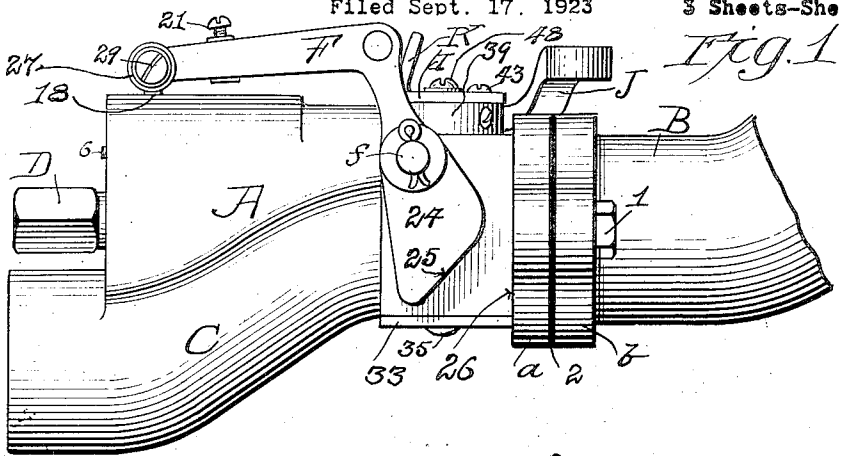

INVENTOR.

Alvis J. Hauskins

By *Wm. T. Brown*
His Att. in C.

Nov. 18, 1924.

1,516, 276

A. J. HAUSKINS

CARBURETOR

Filed Sept. 17, 1923

3 Sheets—Sheet 2

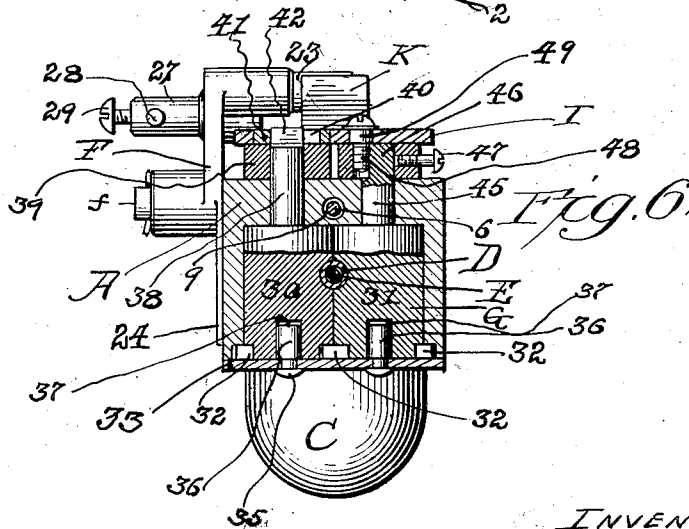
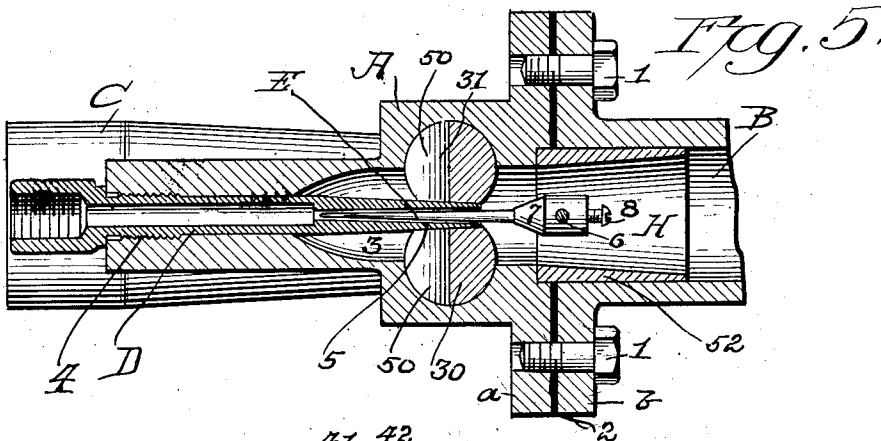
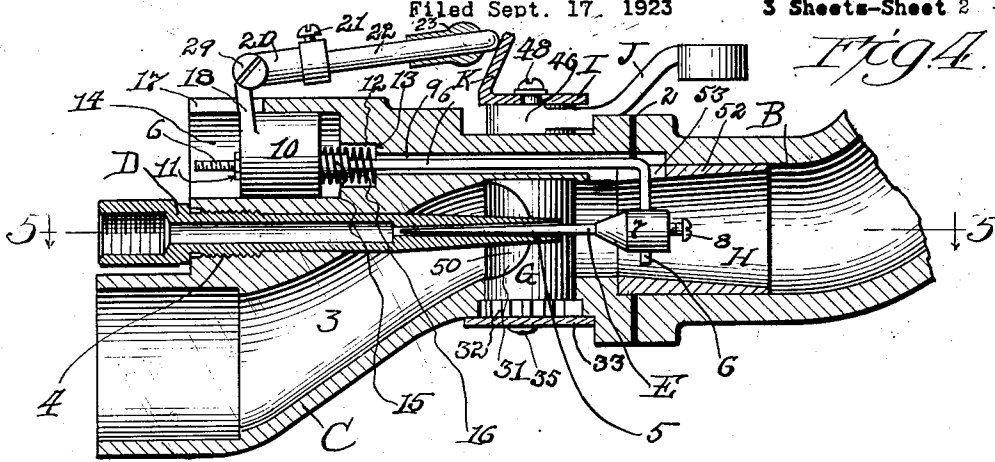

INVENTOR.

Alvis J. Hauskins.

By *Wm. H. Brown*
Attorney.

Nov. 18, 1924.

1,516,276

A. J. HAUSKINS

CARBURETOR

Filed Sept. 17, 1923

3 Sheets-Sheet 3

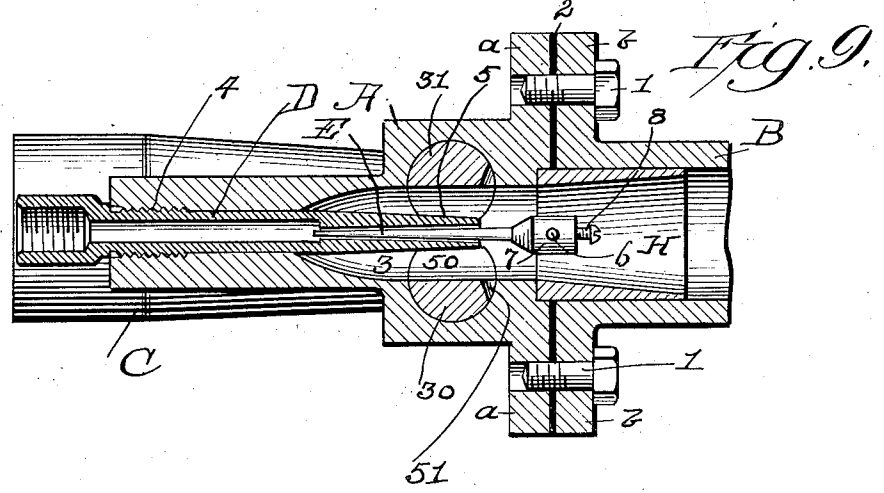
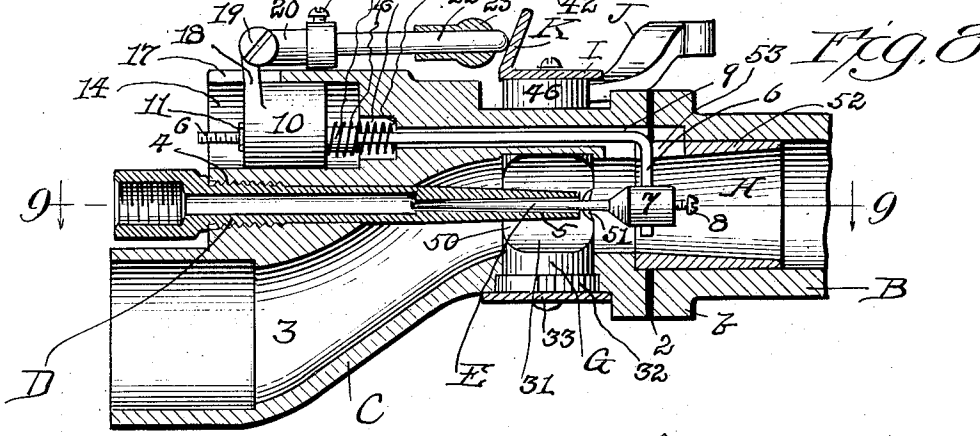
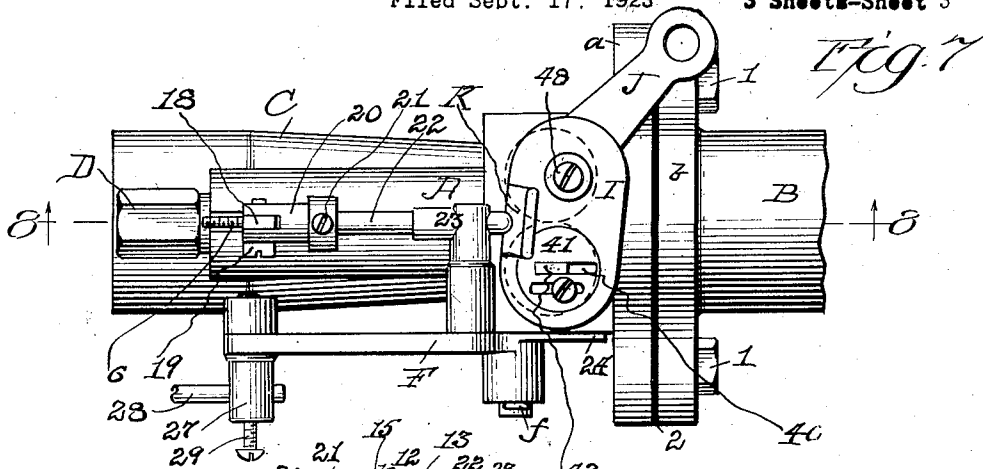

INVENTOR,
Alvis J. Hauskins
By *Walter Brown*
Pat. Attorneys

UNITED STATES PATENT OFFICE.

ALVIS J. HAUSKINS, OF CHICAGO, ILLINOIS.

CARBURETOR.

Application filed September 17, 1923. Serial No. 663,045.

To all whom it may concern:

Be it known that I, ALVIS J. HAUSKINS, a citizen of the United States, residing at Chicago, in the county of Cook and State of Illinois, have invented certain new and useful Improvements in Carburetors, of which the following is a specification, reference being had to the accompanying drawings, and to the reference characters marked thereon, which form a part of this specification.

This invention relates to carburetors and consists of the devices and combinations of devices herein illustrated, described and more particularly pointed out in the appended claims.

One of the objects of my present invention is to produce a carburetor without a float valve, and in which the fuel will be drawn into the carburetor by suction.

Another object is to produce an adjustable device, in the type of carburetor referred to, which will perfectly cooperate with a needle valve to produce proper admixture of air and fuel and thus function with a maximum of efficiency.

Another and important object of the invention is to produce a device which will draw fuel into the mixing chamber when the air valve is closed or open to a very slight extent, thus enabling the operator to start the engine at a slow or "idling" speed.

Another object is to produce in a floatless carburetor such an arrangement of the air valve which will not only take the place of the usual valve of the "butterfly" type but will direct the passage of air to a space immediately surrounding the fuel outlet from the needle valve, thus permitting an automatic and better flow of fuel from the fuel supply tank.

Another object is to produce a carburetor which is simple in construction, easy to assemble, relatively cheap to fabricate, has no complicated parts to get out of order, which affords easy access to those parts which may require adjustment and which may be adapted for attachment to substantially every type of internal combustion engine.

These and other objects and advantages of my invention will be readily comprehended as I proceed with my specification.

In the drawings:

Fig. 1 is a side view of the carburetor as it appears when coupled to the manifold pipe of an internal combustion engine.

Fig. 2 is a top plan view of the same.

Fig. 3 is a bottom plan view of the same.

Fig. 4 is a longitudinal, vertical, sectional view, taken in the plane of the dotted line 4—4 of Fig. 2, looking in the direction indicated by the arrow.

Fig. 5 is a horizontal sectional view, taken in the plane of the dotted line 5—5 of Fig. 4, looking in the direction indicated by the arrow.

Fig. 6 is a transverse, vertical sectional view, taken in the plane of the dotted line 6—6 of Fig. 2, looking in the direction indicated by the arrow.

Fig. 7 is a top plan view of the device, the adjusting lever and connected operating parts being shifted into a position different from the positions shown in Fig. 2.

Fig. 8 is a longitudinal, vertical sectional view, taken in the plane of the dotted line 8—8 of Fig. 7, looking in the direction indicated by the arrow.

Fig. 9 is a transverse, horizontal sectional view, taken in the plane of the dotted line 9—9 of Fig. 8, looking in the direction indicated by the arrow.

A indicates, as a whole, the body of my carburetor, of generally tubular form and provided at one end with a flange *a* adapted to be bolted by bolts 1 to a flange *b* of the manifold B of an internal combustion engine. A packing or washer 2 is inserted between the flanges *a*, *b*. The body A is provided with a central, tubular open end portion C which contains an air passageway 3.

D is the gasoline feed pipe which is screwed into a suitable longitudinal aperture in the housing A by screw threads 4 and projects into the inlet air passageway 3. At its outer or rear end the feed pipe D is interiorly screw threaded so as to afford convenient means of attachment to any suitable source of gasoline or other fuel supply. The feed pipe D is provided at its inner end with a somewhat elongated tapered bore 5 constituting a valve seat for the needle valve E.

The needle valve E enters the tapered bore 5 of the pipe D and is supported upon the short arm member of a longitudinally mov-

55

60

65

70

75

80

85

90

95

100

105

able L-shaped rod 6 by means of the set screw 8 entering the head 7 of the valve E. The long arm member of this valve carrying the rod 6 is positioned in a longitudinal passageway 9 in the body A, and passes through a movable head or piston member 10. The back end of the arm 6 is screw threaded and is secured against forward movement through the piston member 10 by the adjusting nut 11. The passageway 9 in the body A is enlarged, as indicated at 12, to form an annular shoulder 13. The body A is provided with an enlarged opening 14, of a size forming a bearing seat for the member 10 and adapted to permit of the reciprocation of the movable piston member therein. Incidentally the size of the opening 14 also affords access for the convenient manipulation of the adjusting nut 11.

The head or piston 10 carries, on its forward face, a stud 15 around which is wrapped a spiral spring 16. This spring 16 presses at one end against the forward face of the member 10 and at its other end adjacent the annular shoulder 13 which surrounds the rear end of the passageway 9.

The body A, above the opening or recess 14, is longitudinally slotted at 17, the side walls of said slot forming guide-ways for an arm 18. This arm 18 projects from the movable head or piston 10 through said slot, and it has a pivotal connection at 19 with a bifurcated boss 20, which latter is bolted by a screw 21 to a rod 22. This rod 22, at its forward end, has a sliding bearing through a bearing lug 23 which projects laterally from and is integral with the bell crank lever F. This bell crank lever F is pivotally mounted at *f* to the side of the body or housing A, one of its members or arms 24, (the lower one when looking at Fig. 1), having a straight margin 25 adapted, in one position of the lever F, to contact with the rear face 26 of the flange *a* or other stop. The other (rear) member or arm of the lever F is provided with an apertured bearing stud 27 in which one end of an operating rod 28 is adjustably secured by means of the set screw 29, or other convenient means.

The open mouthed passageway 3 is controlled by a two-member valve G, as a whole, which if properly open, will permit air to pass into a mixing chamber H. The air valve G consists of two cylindrical post-like members 30, 31, the central vertical axes of which are at right angles to the longitudinal axis of the fuel pipe D. The members 30 and 31 are each provided on its lower end with a gear or with gear teeth 32 which intermesh, as clearly shown in Fig. 3, so that when the member 30 is rotated on its longitudinal, vertical axis, the other member 31 will also rotate.

A bottom plate 33 is fastened by screws 34 to the under side of the housing A and serves to hold the valve members 30, 31, in position. To this bottom plate are suitably riveted at 35, 35, two interiorly and upwardly projecting pivotal studs 36, adapted to enter axial apertures 37, 37, in the valve members 30, 31, and about which said valve members may rotate.

The valve member 30 is provided at its upper end with an upwardly extending axle or stud member 38, the central, longitudinal axis of which coincides with the similar axis of the stud 36 on which said member 30 is mounted. The upwardly extending stud 38 passes upwardly through a suitable aperture in the body A, and the boss 39 on the regulating arm J, and engages the slot 40 in a cam disc 41. The end of the stud 38, as clearly shown in Figs. 2 and 6, is flattened or reduced in size at 42 so that it may have a sliding fit or bearing in said slot 40. The cam disc 41 is set in a top plate I and is held upon the boss 39 by a set screw or bolt 43, which passes through a slot 44 in said cam disc 41, said slot 44 being parallel to the slot 40 as clearly shown in Figs. 2 and 6. The disc 41, as clearly shown in Fig. 2, is mounted in the plate I, eccentrically to the vertical axis of the stud member 38.

The other valve member 31 is provided with an upwardly extending axial trunnion or stud 45 which extends to the under side of, but not through the plate I, passing through a suitable aperture in a boss 46 also on the arm J. The stud 45 is secured to said boss 46 by the laterally extending bolt 47, and also by the vertically extending bolt 48, which passes downwardly through the plate I, and engages the boss 46, as more clearly shown in Fig. 6. The bolt 48 has an unthreaded part 49 so as to provide relative or laterally rotative movement between the plate I and the boss 46.

The two members of the valve G are suitably recessed or cut away as shown at 50 for the purpose of affording communication between the air passageway 3 and the mixing chamber H, and are also cut away as shown at 51 to afford close contact with the exterior of the end of the fuel tube D. When the two members 30 and 31 are turned so that they contact at the recesses 51 with said tube D, the passage of air will be completely shut off, although, as shown in Fig. 5, fuel may enter said chamber if the needle valve E is moved away from its seat 5, the end of the pipe D opening into said mixing chamber. The mixing chamber H consists of the inner end of the passageway 3 beyond the valve G and the passageway formed in a tubular cylindrical member 52, which latter is seated in the body A and extends forwardly into the manifold B. One portion of the rear wall of the member 52 is slotted at 53 to

provide for the longitudinal reciprocation of the rod 6 which connects the needle valve E with the piston member 10.

The parts are shown open for the free passage of air in Fig. 9, and are shown closed in Figs. 4 and 5.

Shifting of the position of the disc or eccentric 41 is accomplished through the medium of an upwardly extending and forwardly bent flange member K, mounted upon the plate I, the position of the flange K being such as to adapt it for contact with the forward end of the rod 22.

Assume that the parts are in the position shown in Figs. 1, 2, 4 and 5, it will be noticed that the needle valve E is completely seated so that no gasoline or other fuel may enter through the supply pipe D; also that the spring 16 is extended its full length, holding the piston 10 to the proper position to the rear, and holding said needle valve seated because of the retracted position of the rod 6. It will also be noted that the air valve G is closed, the members 30, 31, being in contact against the outside of the end of the needle valve housing D. The lever F is in such position that the end of the arm 22 is lying almost horizontally upon the top of the carburetor and the end of said arm in contact with the lowest portion of the inclined plate K.

From the foregoing explanation, the operation of the carburetor will be readily understood by those skilled in the art. However, a brief explanation will be given.

Assuming the parts have been adjusted properly, the first movement of the operator will be to move the rod 28 which in turn will actuate the bell crank lever F, raise the end of the arm 22. The engine is then cranked either manually or by suitable "starting" mechanism. The "turn over" of the engine will produce a suction in the manifold and through the chamber H, and passageway 9, sufficient to overcome the tension of the spring 16 and thus to draw the piston 10, together with the arm 6 and needle valve E forward toward the manifold, thus moving the valve E off its seat 5 in the member D, and permitting the fuel but no air to be drawn through the pipe C past the needle valve E through chamber H, manifold B, and into the engine cylinder. As the cycle of operations continues, the lever J is moved, which will in turn operate to rotate the air valves 30, 31, and permit the proper amount of air to enter from the passageway 3, through said valve members and into the mixing chamber H to properly mix with the fuel.

It will be noted that the air passage 3 is relatively large as are the openings 50 in the valve members 30, 31, and that the end of the fuel pipe D is centrally located in these openings. Hence when the needle

valve is opened, the fuel is injected by suction into a volume of air and properly mixes therewith, the air and the fuel thus being automatically drawn into and through the carburetor by suction entirely without the necessity of any feed or auxiliary device to force the fuel into the carburetor or to supply it to the carburetor by gravity flow or otherwise. As the valve G is opened further to enlarge this air space surrounding the needle valve, the increased speed of the engine naturally maintains the vacuum and the proper suction pull.

To those familiar with the operation of internal combustion engines and with carburetors, it will be understood of course that the handle J is turned in such direction as will be necessary to admit of the desired amount of air, and that the supply of air may thus be regulated. It will also be understood that the needle valve will be automatically moved forward to open or back to constrict the passageway and shut off the supply of gas, accordingly as the relative position of the arm 22 bears to the inclined plate K, and that when the supply of gas is shut off, the spring 16 will automatically move the bar 6 to the rear and the needle valve E will thus be closed tightly in its seat.

It will be noted that this carburetor when used on an engine for driving vehicles, entirely eliminates the cost and the necessity for the use of any vacuum or other device required for lifting the fuel from the supply tank to a point above the carburetor, since the pipe D is connected directly to the supply tank.

It will be understood that in some uses of the present invention, the spring 15 may be arranged so as to tend to hold the piston 10 in the position shown in Fig. 5, thereby maintaining the needle valve E normally away from its seat and the closing of the valve on the seat be regulated through the arm J.

This and other changes are thought to be so obvious that more specific illustration or description is not necessary.

A particularly important feature of the invention lies in the construction whereby the end of the fuel supply pipe D opens at a point beyond the throttle valve when the latter is closed,—this being more clearly shown in Fig. 5.

I claim as my invention:

1. A carburetor of the class described comprising a casing formed with an air intake passage and a fuel nozzle extending axially into said air passage, valve members adapted to close said air passage adjacent said fuel nozzle, a passageway extending through said casing parallel to said fuel nozzle, and communicating with said air intake passage, a spring actuated piston mounted in

said passageway, a needle valve associated with said fuel nozzle, and means extending through said passageway into said air intake passage and operably connecting said piston and needle valve.

2. In a carburetor of the class described comprising a casing formed with an air intake passage, a fuel nozzle extending into said passage, valve members rotatably mounted in said casing and adapted to close said passage adjacent said fuel nozzle, a needle valve associated with said fuel nozzle, a piston in said casing and mounted for reciprocatory movement by the suction in said air passage and connected to said needle valve, and means operatively connecting said piston and said valve members for positively adjusting said needle valve independent of the vacuum in said air passage.

3. In a carburetor of the class described comprising a casing formed with an air intake passage, a fuel nozzle extending into said air passage, valve members rotatably

mounted in said casing and adapted to close said passage adjacent said fuel nozzle, a needle valve associated with said fuel nozzle, a piston mounted in said casing and connected to said needle valve, said piston being operable by the suction in said air passage to adjust said needle valve relative to said fuel nozzle, cam elements mounted on said valve members, an inclined abutment carried by said cam elements, and means secured to said piston, and operatively engaging said inclined abutment, whereby said piston and needle valve may be adjusted independently of the action of suction on said piston.

In testimony that I claim the foregoing as my invention I affix my signature, in the presence of two witnesses, this 13th day of September, 1923.

ALVIS J. HAUSKINS.

Witnesses:

TAYLOR E. BROWN,
B. L. MACGREGOR.