

D. F. GREENAWALT.
 FILING CASE.
 APPLICATION FILED JUNE 1, 1909.

964,242.

Patented July 12, 1910.

2 SHEETS—SHEET 1.

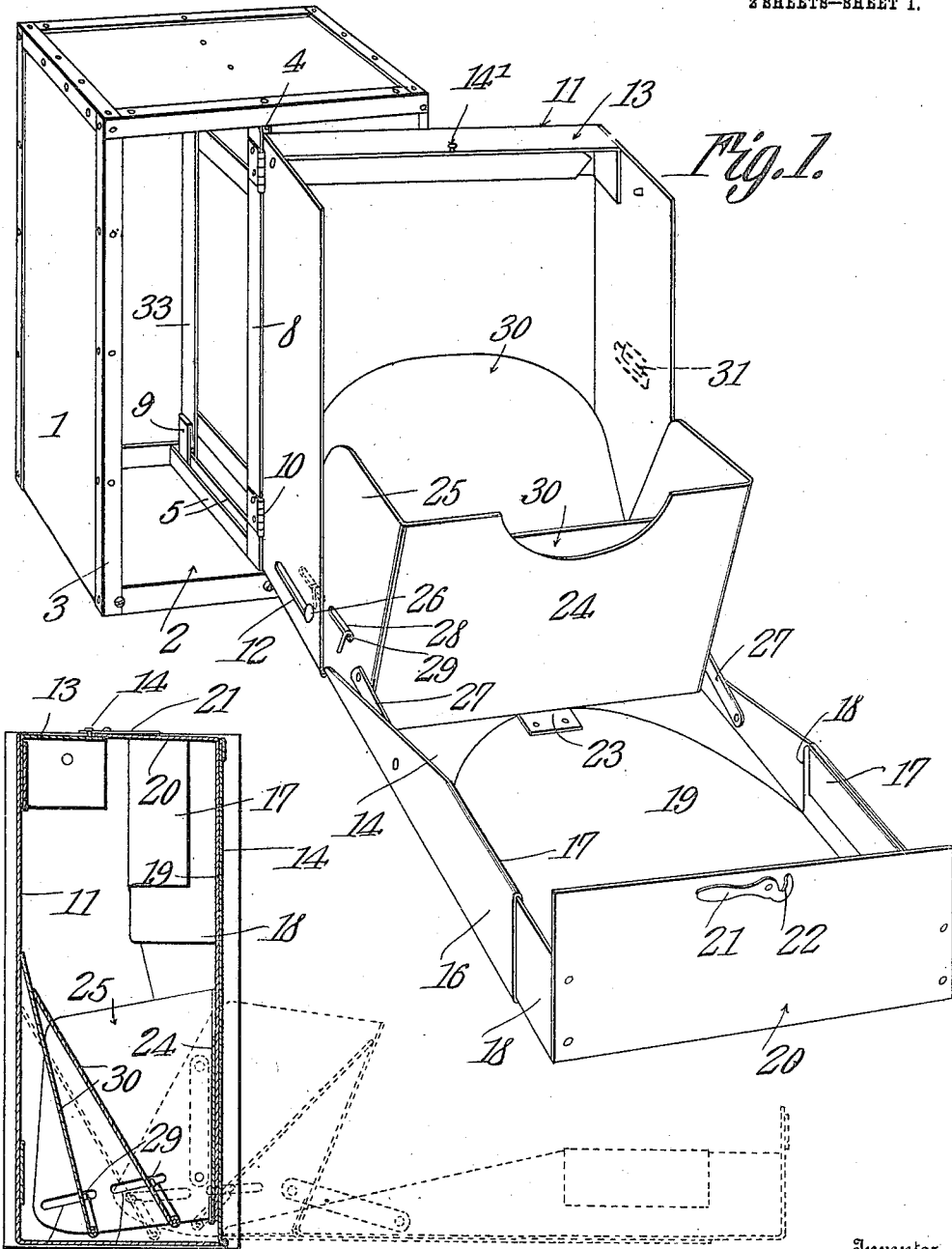

Fig. 1.

Fig. 2. David F. Greenawalt.

Inventor
 David F. Greenawalt
 Witnesses
Herbert D. Lawson

By *C. A. ...*
 Attorneys

D. F. GREENAWALT.
 FILING CASE.
 APPLICATION FILED JUNE 1, 1908.

964,242.

Patented July 12, 1910.

2 SHEETS—SHEET 2.

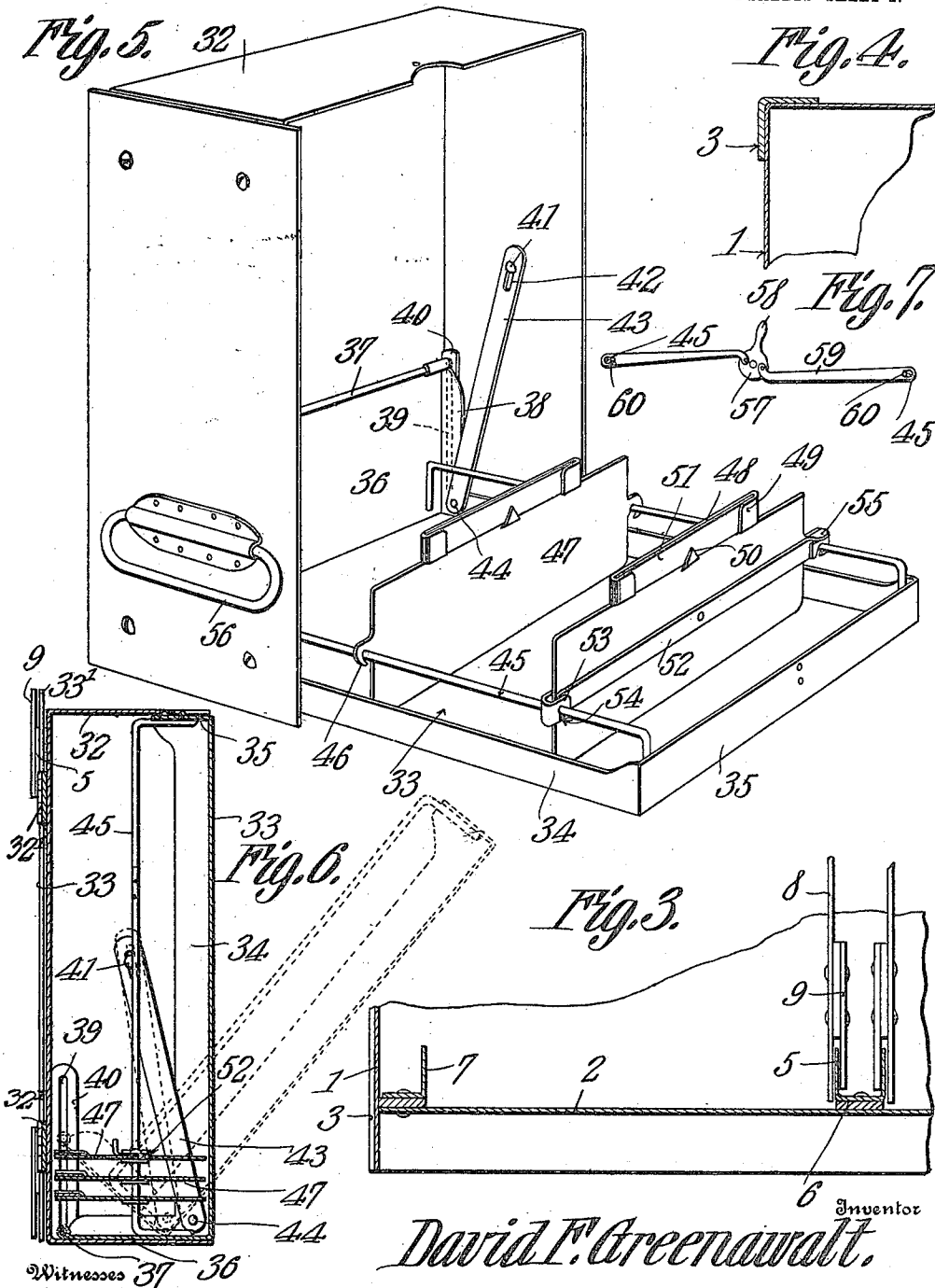

Witnesses
Robert Lawson

Inventor
David F. Greenawalt.
 by *Carroll*
 Attorneys

UNITED STATES PATENT OFFICE.

DAVID F. GREENAWALT, OF PHILADELPHIA, PENNSYLVANIA.

FILING-CASE.

964,242.

Specification of Letters Patent. Patented July 12, 1910.

Application filed June 1, 1909. Serial No. 499,360.

To all whom it may concern:

Be it known that I, DAVID F. GREENAWALT, a citizen of the United States, residing at Philadelphia, in the county of Philadelphia and State of Pennsylvania, have invented a new and useful Filing-Case, of which the following is a specification.

This invention relates to filing cases and its object is to provide an all metal device of this character especially designed for holding bills, documents, checks, small account books and other papers.

Another object of the invention is to provide a housing having a holder which is movable relative thereto but cannot be detached therefrom, said holder being capable of withdrawal from the housing and shiftable into position where the contents thereof are readily accessible.

A still further object is to provide a holder designed to extend automatically when it is moved out of the casing, this holder being provided with pockets, the partitions between which also automatically shift or spread apart when the holder is swung outwardly, thus permitting the papers to be readily removed from the pockets.

Another object is to provide a casing which is free of all partitions, thus permitting air to freely circulate through all of the compartments contained within the casing and minimizing heat in the event of fire.

A still further object is to provide novel means for mounting the holders within the casing, the means permitting the holders to slide into or out of the casing but preventing the same from becoming disconnected from the casing.

With these and other objects in view the invention consists of certain novel details of construction and combinations of parts hereinafter more fully described and pointed out in the claims.

In the accompanying drawings the preferred form of the invention has been shown.

In said drawings:—Figure 1 is a perspective view of a filing case constructed in accordance with the present invention, one of the holders being shown in position outside of the case. Fig. 2 is a vertical section through the case, said section being taken from front to rear and showing the holder

housed within the case, the position of the holder when extended beyond the case being indicated by dotted lines. Fig. 3 is a vertical transverse section through one side portion of the bottom of the case and showing the adjoining guides and portions of the devices engaging the same. Fig. 4 is a section through one corner of the case and showing the reinforce used in connection therewith. Fig. 5 is a perspective view of a modified form of holder used in connection with the case. Fig. 6 is a vertical transverse section through such modified form and showing the closure thereof in position within the body of the holder, one of the positions of said closure being also indicated by dotted lines. Fig. 7 is a detail view of a modified means for securing the partition to the guide rods shown in Fig. 5.

Referring to the figures by characters of reference 1 designates a case preferably formed of sheet metal, the back, sides and top of the case being preferably formed in a single piece, although it is to be understood that they may be formed separately if desired. The bottom 2 of the case is separate from the back and sides thereof and is secured to them by rivets or in any other preferred manner, there being L-shaped reinforcing strips 3 arranged along the side and top corners of the case.

The open front of the case is intersected by a dividing strip 4 and extending backwardly from the upper and lower ends of this strip and along the top and bottom respectively of the case are guide rails 5 preferably formed by the flanges of a channelled strip 6 such as has been indicated in Fig. 3. L-shaped guide rails or strips 7 are also secured upon the top and bottom close to the side walls of the case, these rails 7 being parallel with the rails 5 and spaced from the walls of the case.

An elongated strip 8 is arranged within the case 1 and constitutes a slide, the ends of this strip being arranged to lap one of the rails 5 and there being a retaining plate 9 upon each end portion of the slide. The outer end of each of these retaining plates is spaced from the slide so as to receive the rail 5 between the plate and the slide. Each of the rails 5 has a slide described mounted upon it, and one of the

slides has hinges 10 secured thereto for connecting to it the body 11 of the holder. Said body is preferably formed of sheet metal and one side wall thereof is provided adjacent its lower end with a slot 12 while the upper ends of said walls are connected by a top strip 13 having a stud or projection 14' thereon. The front face of the holder is open and is designed to be closed by a leaf 14 which is hingedly connected to the bottom of the body as indicated at 15. The leaf 14 is provided at its sides with perpendicular flanges 16, the upper edges of which are folded to constitute guides 17 for the reception of flanges 18 upstanding from a slidable leaf extension 19. These flanges 18 are connected by an end strip 20 on which a lever 21 is pivotally mounted, this lever being provided with a hook 22 designed, when the leaf is closed, to engage the stud or projection 14' heretofore referred to. The leaf extension 19 extends throughout the width of leaf 14 and as heretofore stated is designed to slide thereon, the inner end of the extension being hingedly connected as at 23, to a partition plate 24, having side flanges 25 which bear upon the leaf 14. The width of these flanges 25 is slightly less than the depth of the body 11, so that when the leaf 14 is closed said flanges and the partition plate 24 can be seated within the body. A guide stud 26 extends from one flange 25 and is designed to travel within the slot 12, there being links 27 which are pivotally attached to the flanges 25 and also to the flanges 16 and constitute connections therebetween. One or more slots 28 are formed within the flanges 25 and these slots receive arms 29 which extend from the side edges of the partition plates 30 loosely mounted back of the plate 24.

When the parts are in the positions shown in Fig. 1 and it is desired to close the case, the leaf 14 is swung upwardly upon the hinge 15. The links 27 will, therefore slide the partition plate 24 and flanges 25 back into the body of the holder, and, at the same time, the plate 24 will pull upon the leaf extension 19 through hinge 23, thus causing the end strip 20 to move into contact with the adjoining ends of the flanges 16. The flanges 16 will assume positions between the sides of the body 11 and the hooked end 22 of lever 21 can then be moved into engagement with the projection 14', thus securing the leaf in elevated position. It will of course be understood that when the plate 24 is pushed backward in the manner described it will compress the papers contained between the various partition plates and they will therefore be securely held. After the leaf has been raised and secured as described the entire body 11 can be swung upon its

hinges 10 until the body assumes a position in front of the opening in the case 1, whereupon it can be pushed backward into the case, the slide 8 moving along the rail 5 until it assumes a position against the back of the case, at which time the outer end of the body 11 will be flush, or in contact, with the front of the case. It is of course to be understood that the front end of the body 11 is to be provided with a handle, such as indicated at 31 in Fig. 1, whereby said body can be readily withdrawn from the case.

In moving the holder out of the case so as to permit access to be had to the body of the holder, the same is pulled forward until the hinges 10 assume positions at the front of the case, whereupon the body 11 is swung back upon its hinges. The leaf 14 is then unfastened and swung downwardly, the links 27 thus pulling the partition plate 24 forward and pushing the leaf extension 19 outwardly as shown in Fig. 1.

It is to be understood that the case 1 can be provided with any desired number of compartments, each of which contains a holder and all of the holders may be of the same construction, or, if preferred, one or more of the holders can be formed as indicated in Figs. 5 and 6. This holder consists of a box-like body 32 having one face open, the body being connected by hinges 32' to a strip 33' which is similar in construction to the slide 8 and is mounted in the same manner upon one of the guide rails 5. The front or open face of this body 32 is designed to be closed by a leaf 33 having side flanges 34 which are connected at their outer ends by a front strip 35. A base strip 36 connects the rear or inner ends of the flanges 34, the width of this strip being substantially equal to the depth of the body 32. A reinforcing rod 37 extends along the free longitudinal edge of the strip 36 and the ends of this rod project beyond the side flanges 38 of the strip 36 and constitute trunnions designed to work within longitudinal slots 39 formed within guide strips 40 which are secured to opposite walls of the body 32. Stud 41 project inwardly from opposite walls of the body 32 and extend through slots 42 formed in the upper ends of links 43. The lower ends of these links are pivotally connected to the flanges 34 as indicated at 44. Parallel guide rods 45 are arranged adjacent and parallel with the flanges 34 and are connected at their ends to the strips 35 and 36. These rods are designed to be engaged by hooks 46 extending from the ends of plate 47, each of which has an integral extension 48 upon its upper edge, the ends of which are folded toward each other to constitute retaining ears 49 while a prong 50 is struck outwardly from

the plate 47 at a point adjacent the extension 48, this prong cooperating with ears 49 to retain a name strip 51 in position upon the extension. All of the partition plates 5 47 are of the same construction with the exception of the front plate which, as shown in Fig. 5, is provided with a centrally fulcrumed lever 52 the ends of which are designed to swing into a U-shaped guide ear 10 53 at each end of the plate 47, these ears being slotted as at 54 to receive the rods 45. The ends of the lever 52 act as cams for the purpose of binding against the rods and thus securing the plate 47 against movement. A finger-piece 55 may be formed upon one end of the lever 52 to facilitate the actuation thereof.

It is of course to be understood that the front of the body 32 is provided with a handle 56 similar to the handle 31 heretofore described.

When the leaf 33 is swung in a closed position the ends of the rod 37 travel downwardly within the slots 39 and at the same time the links 43 swing forwardly, thus permitting the strip 36 to assume a position flat upon the bottom of the body 32. This operation is reversed when the leaf 33 is swung outwardly and downwardly. The 30 partitions 47 of course constitute means for securely binding together any papers which may be placed between them, the front partition constituting means for holding all of the parts firmly bound together. It will be 35 seen that when the leaf 33 is swung into open position it will not project beyond the case in which the body 32 is mounted, any greater distance than the length of the leaf.

By providing the elongated slots in the ears 53, and by also providing the hooks 46 with elongated openings therein the partitions 47 can be readily tilted so as to permit the papers held therebetween to be more readily inspected. As shown in Fig. 7, instead of providing a pivoted lever 52, for the purpose of securing the partition to the rods 45, a disk 57 may be pivotally mounted upon the front partition 47 and provided with an actuating arm 58. Binding strips 59 are pivotally connected to the disk 57 at diametrically opposed points, these strips extending in opposite directions and being provided with openings 60, through which the rods 45 extend. Obviously by partly rotating the disk 57 the walls of the openings 60 can be caused to bind upon the rods to such an extent as to positively hold the partitions 47 against movement with relation to the rods.

As heretofore pointed out the case 1 can contain one of each of the holders herein described, or, if preferred, it can contain two of either form. Moreover the complete

case constitutes a complete unit and can be combined with a number of other cases if 65 so desired. It will be noted that all parts are formed of sheet metal and are absolutely fire-proof and no portions thereof will bind so as to interfere with the operation of the parts. It is of course to be understood 70 that various changes may be made in the construction and arrangement of the parts without departing from the spirit or sacrificing the advantages of the invention.

What is claimed is:—

1. A device of the class described including a case, and a holder hingedly and slidably connected to the case, said holder including a body having an open face, a leaf movably connected to the body and constituting the closure of said face, and partition plates movably mounted upon the leaf. 75

2. In a device of the class described a holder including a body having an open 85 face, a leaf pivotally connected to the body and constituting the closure of said face, an extension slidably mounted on the leaf, partitions upon the leaf, and cooperating means upon the body, partitions and leaf 90 for shifting the extension when the leaf is moved in one direction.

3. In a device of the class described a holder including a body having an open 95 face, an extensible leaf constituting the closure of said face, and means operated by the opening of the leaf for extending the same.

4. In a device of the class described a holder including a body having an open 100 face, an extensible leaf pivotally connected to the body and constituting the closure of said face, a partition plate slidably engaging the body and normally disposed therein, link connections between said plate and the leaf, and means actuated by the partition 105 plate for extending the leaf when the same is moved in one direction.

5. In a device of the class described a holder including a body having an open 110 face, an extensible leaf movably connected to the body and constituting the closure for said face, a partition plate movably connected to and normally seated within the body, means actuated by the leaf when moved to open position for shifting said 115 plate from the body, and means operated by the plate during such movement thereof for extending the leaf.

6. In a device of the class described a holder including a body having a slotted 120 side wall and an open face, a leaf movably connected to the body and constituting a closure therefor, said leaf being extensible, a partition plate, slotted side flanges thereon movable into the body, means outstanding 125 from the flanges for engaging the slotted

5 wall of the body, partition plates movably supported between and engaging the slotted portions of the flanges of the first mentioned partition plate, means actuated by the movement of the leaf to open position for shifting the partition plates out of the body, and means operated by such movement of the plates for extending the leaf.

In testimony that I claim the foregoing as my own, I have hereto affixed my signature in the presence of two witnesses.

DAVID F. GREENAWALT.

Witnesses:

WALTER E. LAURENCE,
CLAUDE E. TAYLOR.