



(51) International Patent Classification:

A61M 5/20 (2006.01) A61M 5/32 (2006.01)
A61M 5/315 (2006.01) A61M 5/31 (2006.01)

(21) International Application Number:

PCT/EP2021/071606

(22) International Filing Date:

03 August 2021 (03.08.2021)

(25) Filing Language:

English

(26) Publication Language:

English

(30) Priority Data:

20315380.4 07 August 2020 (07.08.2020) EP

(71) Applicant: **SANOFI** [FR/FR]; 54 rue La Boétie, 75008 Paris (FR).

(72) Inventors: **DASBACH, Uwe**; c/o Sanofi-Aventis Deutschland GmbH, 65926 Frankfurt am Main (DE). **KEMP, Thomas Mark**; c/o PA Consulting Group, Back Lane, Melbourn Hertfordshire SG8 6DP (GB). **CORREA, Tomas**; c/o PA Consulting Group, Back Lane, Melbourn Hertfordshire SG8 6DP (GB).

(74) Agent: **SCHMIDT, Christian**; Zwicker Schnappauf & Partner Patentanwälte PartG mbB, Hansastr. 32, 80686 München (DE).

(81) Designated States (unless otherwise indicated, for every kind of national protection available): AE, AG, AL, AM, AO, AT, AU, AZ, BA, BB, BG, BH, BN, BR, BW, BY, BZ, CA, CH, CL, CN, CO, CR, CU, CZ, DE, DJ, DK, DM, DO, DZ, EC, EE, EG, ES, FI, GB, GD, GE, GH, GM, GT, HN, HR, HU, ID, IL, IN, IR, IS, IT, JO, JP, KE, KG, KH, KN, KP, KR, KW, KZ, LA, LC, LK, LR, LS, LU, LY, MA, MD, ME, MG, MK, MN, MW, MX, MY, MZ, NA, NG, NI, NO, NZ, OM, PA, PE, PG, PH, PL, PT, QA, RO, RS, RU, RW,

SA, SC, SD, SE, SG, SK, SL, ST, SV, SY, TH, TJ, TM, TN, TR, TT, TZ, UA, UG, US, UZ, VC, VN, WS, ZA, ZM, ZW.

(84) Designated States (unless otherwise indicated, for every kind of regional protection available): ARIPO (BW, GH, GM, KE, LR, LS, MW, MZ, NA, RW, SD, SL, ST, SZ, TZ, UG, ZM, ZW), Eurasian (AM, AZ, BY, KG, KZ, RU, TJ, TM), European (AL, AT, BE, BG, CH, CY, CZ, DE, DK, EE, ES, FI, FR, GB, GR, HR, HU, IE, IS, IT, LT, LU, LV, MC, MK, MT, NL, NO, PL, PT, RO, RS, SE, SI, SK, SM, TR), OAPI (BF, BJ, CF, CG, CI, CM, GA, GN, GQ, GW, KM, ML, MR, NE, SN, TD, TG).

Declarations under Rule 4.17:

— of inventorship (Rule 4.17(iv))

Published:

— with international search report (Art. 21(3))

(54) Title: DRIVE ARRANGEMENT FOR A DRUG DELIVERY DEVICE

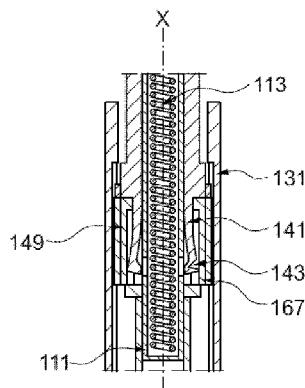

Fig. 5a

(57) Abstract: The invention refers to a drive arrangement for a drug delivery device (100), the drive arrangement comprising: a housing (201) having a proximal end and a distal end, a longitudinal axis (X) extending between the proximal end and the distal end, a plunger rod (111), which is arranged in the housing (201) and movable relative to the housing (201), a drive unit (113) which is arranged to bias the plunger rod (111) to move in the distal direction, i.e. away from the proximal end, a plunger rod release member (117), which comprises at least one plunger rod release feature (141) which is arranged to engage a retention feature (151) of the plunger rod (111), wherein the plunger rod release member (117) is movable relative to the housing (201) from a first position into a second position, wherein, in the first position, the plunger rod release feature (141) engages the retention feature (151), wherein when the plunger rod release feature (141) engages the retention feature (151), the plunger rod (111) is prevented from moving relative to the plunger rod release member (117), and wherein, in the second position, the plunger rod release feature (141) is disengaged from the retention feature (151), thereby allowing the plunger rod (111) to move in the distal direction under the force of the drive unit (113).



Title

5 Drive arrangement for a drug delivery device

Field of the disclosure

10 The present invention relates to an arrangement for a drug delivery device.

Background of the invention

15 Drug delivery devices, such as auto-injectors, are known in the art for dispensing a medicament to the injection site of a patient.

In EP 2 583 708 A1 a medicament delivery device is proposed which comprises a tubular operation member, a tubular extension part and a tubular activation member which are assembled in a housing.

Summary

20 It is an object of the present disclosure to provide an improved arrangement for a drug delivery device.

25 This object is achieved by the subject-matter of the independent claims, where the dependent claims and the remaining disclosure may provide for advantageous embodiments and refinements. It should be noted that the disclosure is not restricted to the claimed concepts but pertains as well to all other concepts and embodiments disclosed herein independently of what is claimed. The scope of protection, however, is defined by the appended claims.

30 One aspect of the present disclosure relates to an arrangement for a drug delivery device. Another aspect of the present disclosure relates to a drug delivery device, which preferably comprises the arrangement. A further aspect relates to a method for assembling an arrangement. Therefore, features which relate to the arrangement do also apply for the drug
35 delivery device and the method and vice versa. As opposed to the arrangement, the drug delivery device may have a reservoir retainer configured to retain a reservoir within a housing and/or a reservoir, which, preferably, comprises a medicament. The reservoir may be arranged

in the reservoir retainer. The reservoir may be syringe, e.g. a syringe with a staked needle. The device may be an auto-injector. The arrangement may be a drive arrangement, i.e. an arrangement having components which operate during a dose deliver operation for which the arrangement is designed. It should be noted that the present disclosure is not restricted to the
5 embodiments which are claimed and that the disclosure may contain other innovative concepts than the claimed ones. Specifically, features can be extracted from the specific context they are disclosed in and may be combined with other features. It goes without saying that features disclosed in conjunction with different embodiments may be combined with one another.

- 10 In an embodiment, there is provided a drive arrangement for a drug delivery device. The drive arrangement comprises:
- a housing having a proximal end and a distal end; a longitudinal axis may extend between the proximal end and the distal end, with the longitudinal axis preferably defining an axial direction or two opposite axial directions, where one direction may be a distal direction, i.e. a direction
15 away from the proximal end and/or towards the distal end, and/or one direction may be a proximal direction, i.e. a direction away from the distal end and/or towards the proximal end, and/or
 - a plunger rod, which is arranged in the housing and movable relative to the housing, and/or
 - a drive unit which is arranged to bias the plunger rod or biases the plunger rod to move in the
20 distal direction, i.e. away from the proximal end, and/or
 - a plunger rod release member, e.g. having a hollow body, such as a sleeve, where the body receives the plunger rod; the plunger rod release member may comprise at least one plunger rod release feature which is arranged to engage a retention feature of the plunger rod, wherein, preferably,
 - 25 the plunger rod release member is movable relative to the housing from a first position into a second position, wherein,
in the first position, the plunger rod release feature engages the retention feature, wherein when the plunger rod release feature engages the retention feature, the plunger rod may be prevented from moving relative to the plunger rod release member, e.g. on account of the
30 engagement, and/or wherein,
in the second position, the plunger rod release feature disengages or is disengaged from the retention feature, thereby, preferably, allowing the plunger rod to move in the distal direction under the force of the drive unit.
- 35 “Distal” is used herein to specify directions, ends or surfaces which are directed or face towards the dispensing end of the drug delivery device or away from a proximal end. For example, the dispensing end of the device may be the distal end. On the other hand, “proximal” is used to

specify directions, ends or surfaces which are directed or face away from the dispensing end of the drug delivery device. For example, the proximal end of the device may be the end furthest away from the dispensing or distal end.

5 In the configuration of the embodiment described further above, the plunger rod may be locked to a plunger rod release member which may be a collar. Accordingly, all further disclosures and features relating to the collar do apply to the plunger rod release member as well and vice versa. The plunger rod release feature may be a collar beam, e.g. movably and/or resiliently connected to a sleeve-like main body portion of the collar. The collar and the collar beam are
10 movable relative to the housing, i.e. they are not fixed to the housing, which is also termed case in the following. The retention feature may be a notch in the plunger rod. The collar beam may be configured to engage the notch, for example by means of a collar prong which may be arranged at the end of the collar beam. The end may be a free end. There can be also two or more collar beams, collar prongs and/or notches accordingly. The prong may protrude radially,
15 e.g. inwardly, from an axially extending portion of the collar beam. The configuration in the first position discussed further above may ensure that the plunger rod cannot move independently from or relative to the collar, unless the engagement of the collar beam to the plunger rod has been released as is the case in the second position. The second position may be an end position for the collar, i.e. a position in which the axial and/or rotational movement of the collar is
20 stopped, e.g. by the collar abutting an axial and/or rotational end stop. If the engagement of the collar beam to the plunger rod is released the plunger rod can move in the distal direction, relative to the housing and the collar, for an injection or delivery operation under the force of the drive unit. In the first position, the engagement between the plunger rod and the plunger rod release member may react the force of the, e.g. pre-loaded, drive unit, if applicable with the aid
25 of a support. When the plunger rod release member is in the second position, the drive unit may be released and the plunger rod may move for the delivery operation. The drive unit may comprise a drive spring, a gas powered drive means or other means to provide energy for a delivery operation of the arrangement. The movement of the plunger rod may be used to drive the delivery of the medicament, e.g. from a reservoir of the drug delivery device. Therefore, it
30 should only occur if a delivery operation is wanted. Therefore, the release of the plunger rod should be reliable and safe. The release of the plunger rod may be subject to a movement of the collar which releases a collar beam from the plunger rod. Without the pre-determined movement(s) of the collar the plunger rod is not released. The movement of the collar may be initiated by the user of the drug delivery device. Therefore, an accidental release of the plunger
35 rod, which would lead to an unwanted delivery operation may be avoided. In particular, when the plunger rod and the plunger rod release member are secured to one another in the first position, they may both move relative to the housing when the plunger rod release member is

moved from the first position to the second position. Therefore, the plunger rod and the release member may have a reliable relative position in the first position and during the movement from the first position into the second position.

5 Moreover, providing a plunger rod release member in addition to the plunger rod avoids having drive features such as protrusions or bosses on the plunger rod which are provided to control the release of the plunger rod. Such features are often provided at the proximal end of the plunger rod and, if those features are dispensed with, the axial extension of a reservoir may be increased, for example, without having to increase the length of the device.

10

In an embodiment, the movement of the plunger rod release member from the first position to the second position comprises axial movement and/or rotational movement. The first position and the second position may be axially and/or angularly offset from one another.

15 In an embodiment in the first position, the plunger rod release feature is radially supported. The radial support may prevent a disengagement of plunger rod release feature and plunger rod as a radial, e.g. radial outward movement, of the plunger rod release feature relative to the plunger rod may be prevented. In the second position, the radial support may be removed, e.g. on account of the movement of the plunger rod release member relative to the housing, to allow a
20 radial movement of the plunger rod release feature relative to the retention feature such that the plunger rod release feature may disengage the retention feature. The radial movement of the plunger rod release feature, which, as has been discussed above already, may be a collar beam, can be prevented by a drive unit holder ring of a drive unit holder which acts as a radial support. The safety for avoiding an accidental release of the plunger rod is improved as the
25 release of the plunger rod release feature requires additionally that a radial support is removed. The support may be provided by a component fixed axially and rotationally relative to the housing or by the housing itself. The support may also assist in reacting the drive unit force, e.g. a part of the force, preferably not the entire drive unit force.

30

In an embodiment the plunger rod is

a) rotationally secured relative to the plunger rod release member by the plunger rod release feature interacting with the retention feature in the first position and/or wherein the movement from the first position to the second position involves rotational movement of the plunger rod release member and the plunger rod relative to the housing and/or

35

b) axially secured relative to the plunger rod release member by the plunger rod release feature interacting with the retention feature in the first position and/or wherein the movement from the

first position to the second position involves axial movement of the plunger rod release member and the plunger rod relative to the housing.

5 It is advantageous for avoiding an accidental release to rotationally secure the plunger rod release member to the plunger rod, so that the movement for releasing the plunger rod is of a different kind than the movement of the plunger rod after release which is axially. It is also advantageous alternatively or cumulatively to axially secure the plunger rod release member to the plunger rod, so that prior to the axial movement after release the plunger rod undergoes another axial movement during the releasing process.

10 In an embodiment the movement of the plunger rod release member and/or the plunger rod from the first position to the second position is or comprises a helical movement relative to the housing. This is advantageous because a combined rotational and axial movement is required in order to a release the plunger rod to the second position. In particular, if the second position is axially and rotationally (angularly) offset from the first position, which may require a helical movement from the first position into the second position, the risk of an accidental release of the plunger rod may be reduced over systems which involve only rotational and/or only axial movement.

20 In an embodiment the plunger rod release member is mechanically coupled to an interface member, e.g. having a hollow body. The interface member may be secured to the housing axially and rotationally. The interface member may be secured to the housing axially and rotationally. Having a separate interface member may have advantages in the manufacturing process. However, in terms of the function it has during operation of the drive arrangement, the interface member could also be integral with the housing. The interface member may be a sleeve. One of the plunger rod release member and the interface member may comprise a helical interface feature, e.g. a protrusion, which is configured to convert an axial movement of the plunger rod release member, preferably relative to the housing and/or driven by the drive unit, and/or an axial force acting on the plunger rod release member, e.g. by the drive unit and/or in the distal direction, into an axial and rotational movement of the plunger rod release member. The other one of the plunger rod release member and the interface member may comprise a feature, e.g. a collar tongue, engaging the helical interface feature to guide the helical movement. The force required for the movement of the plunger rod release member from the first position into the second position may be provided by the drive unit. The interface member may be a drive unit holder. The interface feature may be a drive unit holder sawtooth boss. It may interact with the collar, for example with the collar tongue which is arranged at the collar. The drive unit holder sawtooth boss may be configured as a ramp such that, when the

25
30
35

collar tongue is pushed axially onto the ramp, the ramp forces the rotational movement of the collar or the drive unit holder. The ramp may be inclined into the distal direction in a portion which guides the movement of the plunger rod release feature relative to the housing. This embodiment is particularly advantageous because the drive unit which drives the delivery or injection in a drug delivery device may apply its force axially along the longitudinal axis. This force may be used for generating the rotational movement of the plunger rod release member. The application of the drive unit force in the axial direction to the collar causes the collar to move in the distal direction towards the drive unit holder in a combined axial and rotational movement of the collar.

The plunger rod release member may be mounted on the interface member and movable relative to the interface member. One section of the plunger rod release member may be arranged on the exterior of the interface member. Alternatively or additionally, a section of the plunger rod release member, e.g. a section comprising the plunger rod release feature, may be arranged in the interior of the interface member. The interface member may provide an axial end stop for the plunger rod release member such that the axial movement of the plunger rod release member is stopped by the interface member in the second position.

In an embodiment a deepening is provided in the housing, wherein, in the first position, the plunger rod release feature is angularly and/or axially offset from the deepening, and wherein, in the second position, the plunger rod release feature is received within the deepening, preferably to disengage the retention feature of the plunger rod. Particularly, when in the second position, the plunger rod release feature may be moved or movable into the deepening, preferably by a force provided by the drive unit. The deepening may be a recess extending radially and/or axially. The deepening may be provided in the interface member, such as a drive unit holder ring of the drive unit holder. The deepening may be a groove, into which the collar beam can flex, e.g. outwardly. When the collar beam faces this deepening and flexes outwardly the collar beam may be at the second position. The deepening can be offset axially and/or angularly in the first position relative to the collar beam. If the deepening is offset axially relative to the collar beam a relative axial movement of the collar to housing or the drive unit holder is required to reach the second position in which the collar beam can flex outwardly into the deepening. If the deepening is offset relative to the collar beam angularly in the first position a relative rotational movement of the collar to housing or the drive unit holder is required to align the collar beam and the deepening such that the collar beam (release feature) can flex into the deepening. The collar may comprise two or more collar beams. Accordingly, the housing or the drive unit holder ring can comprise two or more deepenings which are adjusted such that the two or more collar beams can flex into a deepening. The deepening may define the second position of the collar or

plunger rod release member relative to the housing. This configuration may assist in ensuring that the plunger rod is only released from the collar, when the collar has been rotated into the second position. This rotation may be concurrent with the axial movement of the collar relative to the housing.

5

In an embodiment, in the first position, the engagement between the plunger rod release feature and the retention feature reacts the force of the drive unit, which may be pre-stressed. This has the advantageous consequence that as soon as the plunger rod is released it will be pushed in the distal direction, due to the force of the drive unit, for initiating the injection process.

10 Moreover, the force of the drive unit may be used to drive axial movement of the plunger rod release member or collar relative to the housing. Also, the force of the drive unit may be used to disengage the plunger rod and the plunger rod release member, e.g. to move the release feature, e.g. radially and/or outwardly, relative to the plunger rod.

15 In an embodiment, in the first position, a rotational movement of the plunger rod release member is blocked by a blocking interface established between the plunger rod release member and a moveable trigger member, e.g. by blocking interface features on the members which engage one another to prevent the rotation. The rotation which is prevented may be rotation in the same direction as the rotation which may be necessary to move the plunger rod
20 release member into the second position. The trigger member may be moveable, preferably relative to the housing, to release the blocking, e.g. axially movable, such as proximally. The trigger member may be rotationally locked relative to the housing. For example, it may be rotationally locked to the interface member, e.g. by engaging axial guide slots provided in the interface member such as on an outer surface thereof. The interface member may, in turn, be
25 rotationally locked to the housing, e.g. by snap features or other suitable means of securing two parts to one another. The trigger member may react a part of the drive unit force in the first position which may be transferred to the trigger member via the plunger rod release member. The trigger member may provide the interface to the user which is contacted by the user to trigger or initiate a dispensing operation. The moveable trigger member may be a needle cover
30 which is movable axially along the longitudinal axis. Features disclosed in the following for the needle cover apply for the trigger member as well. The needle cover may comprise a blocking interface feature which may be a needle cover leg rib. The needle cover is movable relative to the housing. In a first position the needle cover leg rib may block a rotation of the collar, e.g. by angularly abutting a feature on the collar. In a second position, the needle cover leg rib does not
35 block the rotation of the collar. The collar may comprise a collar firing boss which interacts with the needle cover leg rib such that if they overlap axially in their position and/or abut a blocking of the rotation occurs and if they do not overlap or no longer abut a rotation of the collar is

allowed. In the first position of the needle cover the needle cover blocks rotation of the collar. It is also possible that the needle cover comprises two needle cover leg ribs and/or that the collar comprises two collar firing bosses which act in the same manner. The rotation of the collar takes care that the collar beam is facing the deepening of the drive unit holder ring in the second position, so that it can flex outwards and release the plunger rod.

In an embodiment the interface member comprises a guiding portion for guiding the moveable trigger member axially along the longitudinal axis. This reduces possibly occurring torques acting on the moveable trigger member as the lever arm or leverage may be reduced as compared to a situation without a guiding portion. The trigger member may extend from the distal end up to the plunger rod release member and have one or more arms extending proximally. The guiding portion may be arranged closer to the plunger rod release member, especially closer to the blocking interface feature on this member, than to the distal end of the trigger member. This configuration is particularly advantageous, if the trigger member has a certain length. For example, the trigger member may protrude distally from the housing and the plunger rod release member may be proximally offset from the distal end of the housing. The trigger member may have a sleeve-like portion which protrudes distally from the housing in the first position of the plunger rod release member. One or more arms of the trigger member may extend axially towards the proximal end. The respective arm may be connected to the sleeve-like portion. The respective arm may be guided by the guiding portion in a region between the distal end of the housing and the blocking interface of the trigger member with the plunger rod release feature. The blocking feature of the trigger member may be provided proximally offset from the guiding portion, preferably by a distance which is smaller than the proximal offset of the guiding portion or the interface member from the distal end of the housing.

In an embodiment, the interface member has a portion which is received in the interior of the plunger rod release member. The interface member may have another or second portion, e.g. axially offset from the portion, which is not received in the interior. The second portion may overlap radially with the plunger rod release member, e.g. a sleeve-like portion thereof.

In an embodiment the interface member comprises a radial outward step or flange, wherein

- a) the radial outward step or flange has an opening wherein the plunger rod release feature extends into the interior of the interface member through the opening, particularly from the exterior, and/or
- b) the radial outward step or flange defines an end stop surface for the plunger rod release member which stops movement of the plunger rod release member, particularly axial movement, when the plunger rod release feature is moved towards the second position or has

reached the second position. The deepening may be provided on an interior surface of the interface member, e.g. in a section distally offset from the opening.

5 In an embodiment, the interface member which may be a drive unit holder may comprise, e.g. at the end a distal portion a drive unit holder ring. The drive unit holder ring may comprise the deepening. The plunger rod release feature, i.e. the collar beam extends into the interior of the ring, such that if the ring is adjusted appropriately relative to the collar, the collar beam can flex into the deepening provided in the ring. The drive unit holder comprises a fixing portion for fixing the drive unit holder to the housing. Therefore, the drive unit holder is not moveable relative to
10 the housing. The plunger rod release feature, i.e. the collar beam, may extend into the opening of the drive unit holder which is a part of the drive unit holder ring. At its inside of the drive unit holder ring the deepening is arranged into which the collar beam can flex outwardly for releasing the plunger rod. Therefore, also at least a part of the plunger rod is arranged at the inside of the drive unit holder ring. In this configuration the positionally fixed part, i.e. the drive
15 unit holder ring, is also the starting position of the plunger rod at its release position. This gives the overall device additional stability. Alternatively or cumulatively the positionally fixed part, i.e. the drive unit holder and its radial outward step or flange, defines an end stop for the collar. This is also advantageous as the end stop is at a mechanically fixed part. An end stop for the collar means a defined status for its axial and rotational state relative to the drive unit holder, e.g. as
20 an initial position for a priming operation or as an end position to release the plunger rod.

In an embodiment the interface between the plunger rod release feature and the retention feature which is established in the first position comprises at least one surface which is inclined relative to the longitudinal axis, i.e. oblique to the longitudinal axis and non-perpendicular. The
25 interface can comprise a collar prong with an inclined surface. An inclined surface is advantageous as the force of the drive unit applies a force in the axial direction to the plunger rod. Via the inclined surface, this force can be used to generate a radial movement to release the engagement between plunger rod release member and plunger rod. When the collar prong is locked into the plunger rod via a notch the force is applied to the collar prong as well resulting
30 in a force towards its inclined surface such that the collar beam flexes radially outward. As a result, once the collar beam is at a position, axially and/or rotationally, facing the deepening, the release of the plunger rod is achieved by a transfer of the force of the drive unit to the inclined surface of the prong, without any additional adjustment.

35 Consequently, the drive unit force may be used to move the plunger rod release feature out of engagement with the retention feature. The inclined surface, e.g. on the plunger rod release feature, when subjected to an axial load such as the drive unit force, generates a radial force

acting on the plunger rod release feature which, if not reacted, such as by the support, e.g. in the interface member, or the housing, causes a radial movement of the plunger rod release feature, e.g. in the outward direction, to disengage the plunger rod release feature and the retention feature.

5

In an embodiment, the plunger rod release member comprises a, preferably rigid main body or main body portion, and the plunger rod release feature is movably connected to the main body, e.g. finger-like. The main body may provide mechanical stability where the engagement/disengagement functionality may be provided by the flexible plunger rod release feature connected to the main body. The main body may be sleeve-like.

10

In an embodiment, the plunger rod release feature is elastically deflectable, e.g. relative to the main body.

15 In an embodiment, the interface member is a member separate from the housing but axially and rotationally secured to the housing. The interface member, e.g. the drive unit holder, is separately manufactured but is fixed to the housing when the drive arrangement is assembled. Therefore, the drive unit holder along with the collar, the plunger rod, and the drive unit can be assembled as a separate unit and then fixed to the housing. This provides advantageous flexibility in manufacturing and assembling of the drive arrangement.

20

In another aspect a drug delivery device is provided which comprises a drive arrangement and a reservoir, e.g. a syringe, and may comprise a medicament for injection. The reservoir, e.g. the syringe, may comprise a volume equal to or greater than 2,5 ml, in particular a volume of 3ml.

25

In an embodiment the drug delivery device is a needle-based injection device with integrated non-replaceable container, where each container holds a single dose, whereby the entire deliverable volume is expelled when the device is operated for delivering the single dose. The drug delivery device may fulfil the requirements of ISO 11608-1, 3rd ed. 2014-12-15.

30

Brief description of the drawings

Embodiments will now be described, by way of example only, with reference to the accompanying drawings, in which:

35

Fig. 1A is a schematic drawing of components of an embodiment of a drug delivery device;

- Fig. 1B is a schematic 3D-drawing of the drive spring holder in a first view;
- Fig. 1C is a schematic 3D-drawing of the drive spring holder in a second view;
- Fig. 1D is a schematic 3D-drawing of the needle cover;
- Fig. 1E is a schematic 3D-drawing of the collar;
- 5 Fig. 1F is a schematic 3D-drawing of the plunger rod;
- Fig. 1G is a schematic 3D-drawing of the needle cover, drive spring holder, syringe and collar in an assembled state;
- Fig. 1H is a schematic 3D-drawing of the collar, plunger rod and drive spring in an assembled state;
- 10 Fig. 2A is a side view of the case of the drug delivery device from a first direction;
- Fig. 2B is a schematic 3D drawing of the assembled drug delivery device in a transparent view from a first direction;
- Fig. 2C is a schematic 3D cross-sectional drawing of the drug delivery device from a first direction in an assembled state;
- 15 Fig. 2D is a side view of the case of the drug delivery device from a second direction, turned by 90 degrees around its longitudinal axis with respect to Fig. 2A-2C;
- Fig. 2E is a schematic 3D drawing of the assembled drug delivery device in a transparent view from the second direction;
- Fig. 2F is a schematic 3D cross-sectional drawing of the assembled drug delivery device from
- 20 the second direction;
- Fig. 3A is a schematic 3D drawing of the collar and the needle cover legs at the priming step;
- Fig. 3B is a schematic 3D drawing of the collar, the needle cover legs and the drive spring holder at primed position;
- Fig. 3C schematically illustrates an unprimed state;
- 25 Fig. 3D schematically illustrates a primed state;
- Fig. 4A is a schematic 3D drawing of the collar, the drive spring holder and the needle cover legs;
- Fig. 4B is a schematic cross-sectional drawing of the collar beams being connected with the plunger rod;
- 30 Fig. 5A is a schematic cross-sectional drawing of the collar beams flexed outwards;
- Fig. 5B is a schematic cross-sectional drawing of a section of the drug delivery device;
- Fig. 5C is a schematic cross-sectional drawing of the drug delivery device;
- Fig. 6A is a schematic drawing of a section of the drug delivery device with the needle cover at the distal end along the first axis;
- 35 Fig. 6B is a schematic drawing of a section of the drug delivery device in Figure 6A rotated by 90 degrees;
- Fig. 7A is a schematic drawing of a section of the drug delivery device in an unprimed state;

Fig. 7B is a schematic drawing of a section of the drug delivery device in a primed state;
Fig. 7C is a schematic drawing of a section of the drug delivery device at the distal end showing the cap being removed when the delivery operation has been initiated;
Fig. 7D is a schematic drawing of a section of the drug delivery device after the dose delivery operation has been completed and the needle cover has been locked;
5 Fig. 8A and Fig. 8B illustrate an embodiment of a needle cover lock mechanism suitable for the drug delivery device.

Detailed description

10

The same reference numbers apply to the same features throughout the figures and the following explanations.

15

An embodiment of a drug delivery device is described in the following with reference to figures 1A to 7D.

20

Figure 1A is a schematic drawing of components of the drug delivery device 100, in particular of an auto-injector. The device comprises a housing or case 201 (shown for example in Figure 2A), which is depicted as comprising a front case 107 and a rear case 121. A multi-part case may be advantageous from an assembling perspective. The drug delivery device 100 further comprises a cap 101 which may be attached to the case, e.g. to the front case 107. Instead of a multi-part case, a unitary case may be employed as well.

25

The case 201 is adapted to hold a medicament container, such as a syringe 109. The syringe 109 may be a pre-filled syringe and comprises a needle for injecting a medicament. The reservoir, e.g. the syringe, may receive a medicament having a volume equal to or greater than 2,5ml. The needle may be covered by a protective needle shield 125, which is why the needle is not visible in Figure 1A. The needle is disposed at the distal end of the syringe. A proximal end of the syringe may be closed by a movable bung or stopper 129 (see Figure 2B, for example)
30 which is movably retained in a syringe barrel 127 of the syringe 109. When the stopper is displaced in the distal direction, i.e. towards the needle, the liquid content of the barrel may be dispensed from the syringe via the needle. Instead of the syringe, a cartridge with or without a pre-mounted needle may be provided as a drug or medicament container or reservoir. The cap 101 may include a grabber 103 (e.g. a barb, a hook, a narrowed section, etc.) which can act as
35 a removal mechanism for the needle shield 125. The cap 101 may comprise grip features (not shown) for facilitating the removal of the cap 101 (e.g. by twisting and/or pulling the cap 101 relative to the case 201). When the drug delivery device 100 and/or the syringe 109 are

assembled, the protective needle shield may be removably coupled to the needle and/or the syringe. The needle shield may be interlocked with the cap, e.g. via the grabber, and removed together with the cap to prepare the device for operation.

- 5 The device comprises a needle cover 105 which may be movably retained within the case 201, e.g. telescopically. The needle cover 105 may be arranged to cover the needle, preferably when the needle shield has been removed and/or when the delivery operation has been completed. The needle may be the one comprised by the syringe or one provided in the case when a cartridge without a pre-mounted needle is used as container or reservoir. The needle cover may
- 10 function as a trigger member, which, when moved relative to the case from an initial position, e.g. in the proximal direction, triggers the dose delivery operation which may be spring-driven. Alternatively, another member, such as a button, may be provided as trigger member (not illustrated).
- 15 The device further comprises a needle cover spring 119, which may be arranged to cooperate with the needle cover 105 in the drug delivery device. The needle cover spring may be arranged to bias the needle cover, e.g. distally. Accordingly, when the needle cover is moved proximally relative to the housing the needle cover spring may be loaded and the force of the loaded spring may be used to drive the needle cover distally, e.g. once an element reacting the spring force,
- 20 such as the skin of the user, is removed from the needle cover 105.

A plunger rod 111 of the device is arranged to be driven by a drive spring 113 of the device, e.g. a compression spring and/or a helical spring. When the plunger rod 111 moves distally relative to the syringe, the medicament in the syringe is dispensed from the device. The plunger rod

25 may move distally relative to syringe and case under the force of the drive spring during the delivery operation. The drive spring may be pre-loaded. The entire force required to move the plunger rod may be provided by the pre-load in the drive spring. No loading or setting operation may be required. The container may contain an amount of medicament, which is sufficient for only one delivery operation. Thus, the device may be a, e.g. disposable, device for

30 administering a single dose of medicament. The drive spring force, e.g. the force with which the drive spring is pre-loaded, may be greater than or equal to any one of the following values: 20N, 25N, 30N, 45N or even higher.

The device 100 further comprises a collar 117. The collar is arranged to be operatively

35 connected to a drive spring holder 115 of the device 100 as will become apparent from the further explanations below. The drive spring holder 113 provides a cavity in which the drive spring 113 is received. The cavity may be provided by a sleeve-like portion of the drive spring

holder. The drive spring is at least partly received in the drive spring holder. A proximal surface of the drive spring may abut a distal surface of the drive spring holder. The drive spring holder may react the force of the pre-loaded drive spring.

5 The plunger rod 111 serves for transferring the force of the drive spring 113 to the syringe 109, particularly the stopper 129. The drive spring may be retained between a proximal facing surface of the plunger rod 111, e.g. an inner surface, and a distally facing surface of the drive spring holder 113. The syringe barrel and the needle may be axially secured in the case, e.g. by means of an appropriate bearing surface provided in the interior of the case or by means of an
10 additional syringe holder. The drive spring 113 is arranged within the plunger rod 111 biasing the plunger rod 111 in the distal direction. In another exemplary embodiment, the plunger rod 111 may be solid and the drive spring 113 may engage the plunger rod at a proximal end of the plunger rod 111. Likewise, the drive spring 113 could be wrapped around the outer diameter of the plunger rod 111 and extend within the syringe 109. The needle cover spring 119 may be
15 operatively coupled between the needle cover 105 and the collar 117.

When the drug delivery device 100 is assembled all components shown in Figure 1A are joined along a longitudinal axis X which is hinted in the explosion view in Figure 1A by the dashed line. In the assembled state, the axis X extends between the proximal end P and the distal end D of
20 the device.

Figure 1B is a schematic 3D-drawing of the drive spring holder 115 and the plunger rod 111 in a first view. The drive spring holder 115 comprises a drive spring holder ring or ring portion 167 (see Figure 1C) and two drive spring holder arms 153 which extend from the drive spring holder
25 ring portion 167 defining a, e.g. cylindrical, drive spring holder cavity 169. Instead of the drive spring holder arms 153, a drive spring holder sleeve portion may be provided. The ring portion may protrude radially beyond the arms or the sleeve portion such that a proximally facing surface of the drive spring holder is provided which may define an axial end stop for the collar 117. The proximally facing surface may be configured to react the drive spring force in a pre-
30 assembled unit, in which the drive spring may be loaded already. This unit may comprise the collar, the plunger rod, the drive spring and the drive spring holder. The plunger rod 111 may be retained in the drive spring holder 115. The plunger rod 111 may be arranged in the drive spring holder cavity. The drive spring holder arms 153 are connected at their endings remote from the ring portion by a drive spring holder disc portion 155. The drive spring holder, e.g. the disc
35 portion, may react the drive spring force, e.g. during the operation of the device or when the plunger rod, the drive spring holder, the drive spring and the collar are assembled as a unit before the unit is assembled with the remaining parts of the device. The drive spring holder ring

portion 167 comprises, e.g. at its outer lateral surface, two drive spring holder rails or slots 157. The rails or slots 157 are arranged to cooperate with needle cover legs 131 (see further below) to axially guide the movement of the needle cover legs. In other words, the legs 131 can move only along the axis X and relative rotation between the legs 131 and the drive spring holder is prevented or at least blocked. Further, the drive spring holder ring 167 comprises one or more drive spring holder sawtooth bosses 139. The bosses are angularly separated. The bosses may extend from the proximally facing surface of the drive spring holder ring portion, e.g. in the proximal direction. The bosses 139 may be placed at an area of the drive spring holder ring 167 facing a distal surface of the collar 117, e.g. in the area where the drive spring holder arms 153 are emerging from the drive spring holder ring 167. The drive spring holder sawtooth bosses 139 may be provided to interact with one or more collar tongues 145 as will be described further below. Further the drive spring holder 115 comprises a fixing portion or feature 171, e.g. one or more radially oriented protrusions, for fixing the drive spring holder 115, expediently rotationally and axially, to the case 201, in particular to the front case 107, e.g. via a snap fit. The fixing portion or feature 171 may be provided on an outer lateral surface of the ring portion. A portion of the needle cover legs 131 may be arranged in a region between the inner wall of the case and an outer wall of the drive spring holder, e.g. of its ring portion, in the drug delivery device.

Figure 1C is a schematic 3D-drawing of the drive spring holder 115 in a second view, showing drive spring holder grooves 149 at the inner radius of the drive spring holder rail 157 in which collar beams 141 of the collar 117 in a connected state can flexibly move radially outwards as described in conjunction with Figure 5A below. Further the drive spring holder ring 167 comprises at its proximal end a distal end stop surface 168 which stops the collar 117 from moving further in the distal direction.

Figure 1D is a schematic 3D-drawing of the needle cover 105 comprising two, e.g. rectangular shaped, needle cover legs 131 extending parallel to each other away from a, e.g. cylindrically shaped, front section 133 of the needle cover 105. The needle cover legs may be elongated. At or near their proximal ends the needle cover legs 131 comprise needle cover leg ribs 135. The needle cover leg ribs may face inwardly and/or face one another. The needle cover leg ribs 135 may interact with the ramped collar priming bosses 147, see figures 1F, 3A and 4A. The needle cover legs 131 further comprise, e.g. rectangular, needle cover cutouts 137 which can connect or interact with guide features or serrate sections 205 of the front case 121. The needle cover 105 further comprises needle cover lock arms 163 with needle cover ramps or lock features 165. The needle cover lock arms are located in the interior of the ring-shaped front section 133. The needle cover lock arms with the lock features 165 may can block the needle cover 105 from

movement in the proximal direction by abutting a front wall 601 of the case 201, as shown and explained in more detail in Figure 6A.

Figure 1E is a schematic 3D-drawing of the collar 117. The collar comprises a collar tube portion 123, which may be circumferentially closed, where this is not necessary for the functionality. It may, however, be advantageous as, in this case, access to components in the interior of the collar is prevented. This is of a particular advantage, if the collar defines a section of the outer surface of a pre-assembled unit as discussed above. At the proximal end of the collar tube 123 a circular edge or flange 161 is provided. The edge or flange 161 may protrude radially beyond the tube portion 123. The edge or flange 161 may provide a bearing surface for the needle cover spring 119. The opposite bearing surface of the needle cover spring 119 may be formed by the end of the needle cover legs 131. At the distal end of the collar tube portion 123 two collar beams 141 are provided which extend axially away from the collar tube portion 123, e.g. along the axis X. At the free ends of the collar beams 141 collar prongs 143 are provided which are directed radially inwardly and/or towards each other. The collar prongs 143 are shaped with a ramp on a proximal surface. The ramp may have a slope, which defines an angle less than 90° with the axis X as seen in the proximal direction. The distal surface of the prongs may extend perpendicularly relative to the axis X. At the distal side of the collar tube 123 one or more collar tongues 145 are provided at the inner radius of the collar tube 123. For example at the distal side of the collar tube 123, at least one ramped collar priming boss 147 is provided, preferably at the outer surface of the collar. Further, at least one collar firing boss 159 is provided to interact with the needle cover leg ribs 135 of the needle cover legs 131 is provided at the outer surface of the collar, e.g. at the collar tube 123. A plurality of priming bosses and firing bosses may be provided. The collar priming boss 147 and the spring holder sawtooth boss 139 may have ramped surfaces which angularly face one another or face in opposite angular directions. The slopes of the ramped surfaces of the priming boss and of the drive spring holder sawtooth boss may be helical and/or the ramped surfaces may be inclined in the same direction. The ramped surface of the priming boss may face, e.g. partly or predominantly, in the distal direction. The ramped surface 173 of the sawtooth boss may face, e.g. partly or predominantly, in the proximal direction.

Figure 1F is a schematic 3D-drawing of the rod with a notch 151. The notch 151 has a quadratic opening but it can also have any other shape, e.g. rectangular or circular.

Figure 1G is a schematic 3D-drawing of the needle cover 105, the drive spring holder 115, the collar 117 and the syringe 109 in an assembled state. The syringe 109 is operatively connected to the plunger rod 111 and the drive spring 113 so that the plunger rod can transfer the force of

the drive spring 113 to the stopper in the syringe 109. The needle cover leg ribs may interact with the collar firing bosses (not explicitly shown).

5 Figure 1H is a schematic 3D-drawing of the collar 117, the plunger rod 111 and the drive spring 113 in an assembled state. The plunger rod 111 is cylindrically shaped and hollow forming a cylindrical cavity which extends along the axis X and which is closed at its distal side. The drive spring 113 which is also generally cylindrically shaped is arranged within the cavity of the plunger rod 111. The collar prongs 143 of the collar beams 141 are directed radially inwardly and are interlocked with notches 151 of the plunger rod 111. As long as this interlock is
10 established, the collar and the plunger rod are axially and rotationally locked to one another.

Figures 2A-2C show the drug delivery device 100 from the same perspectives and in the same state. The state may be a state where the device is ready to be used for an injection operation, e.g. out of the box.

15 Figure 2A is a drawing of a side view of the case 201 of the drug delivery device 100 showing the cap 101, the front case 107 and the rear case 121. The front case 107 comprises one or more viewing windows 203 which allow a visual inspection of the syringe 109, e.g. to verify that there is still sufficient medicament in the syringe or that the device has not yet been operated or
20 the integrity of the drug compound prior to use. The viewing windows 203 are located on opposite sides of the front case 107 with regard to the axis X, which allow the visual inspections outlined above and additionally an inspection of the optical clarity of the drug.

Figure 2B is a schematic 3D-drawing of the assembled drug delivery device 100 in a primed
25 condition or state ready for a dispensing or delivery operation, wherein the case 201 is transparent along the axis X. It shows the syringe 109 and the plunger rod 111. It further shows the drive spring holder 115 from which the plunger rod 111 protrudes in the distal direction, and the portion 171 for fixing the drive spring holder 115 to the case 201. It further shows the needle cover spring 119 surrounding the outer radius of the collar tube portion 123 and being confined
30 by the collar circular edge or flange 161 at the proximal side of the collar tube portion 123.

Figure 2C is a schematic cross-sectional drawing of the drug delivery device 100. It shows the syringe 109 and the drive spring 113 next to it. The drive spring 113 is covered by the plunger rod 111. It also shows a cross-section of the needle cover spring 119 and collar tube 123
35 wherein the needle cover spring 119 is confined in its expansion in the proximal direction by the collar circular edge 161 of the collar tube 123 and distally by the needle cover legs 131. Further are shown the needle cover leg ribs 135 of the needle cover 105 guided in the drive spring

holder slots 157 of the drive spring holder 115. The front case 107 comprises serrate sections 205 which interact with the, e.g. rectangular, needle cover cutouts 137 of the needle cover 105 such that the needle cover 105 is secured in the rotational or angular direction by the serrate sections 205 but can only move along the axis X by a distance limited by the length of the
5 needle cover cutout 137, particular at least in the distal direction.

Figures 2D-2F show the views of the drug delivery device 100 similar to the ones above, where, however, the device is rotated by 90 degrees around its longitudinal axis compared to the view in figures 2A-2C.

10

Figure 2D is a schematic cross-sectional drawing of the case 201 of the drug delivery device 100 showing the cap 101, the front case 107 and the rear case 121. The viewing windows 203 of the front case 107 are only indicated by indentations in the drawing.

15 Figure 2E is a schematic 3D-drawing of the assembled drug delivery device 100 wherein from the viewing side the case 201 is transparent along the longitudinal axis, analogue to Figure 2B. It is shown a needle cover leg 131 of the needle cover 105 with the needle cover cutout 137. The serrate section 205 of the front case 107 intercepts with the, e.g. in top view rectangular, needle cover cutout 137 of the needle cover 105 such that the needle cover 105 is secured in
20 the rotational direction and can only move in the direction of the axis X according to the length of the needle cover cutout 137. In Figure 2E the serrate section 205 is located close to the proximal end of the needle cover cutout 137, such that the needle cover 105 can move towards the collar 117, i.e. proximally. This movement will happen when the user triggers the delivery operation to apply the medicament contained in the syringe 109. Before the delivery operation is
25 triggered that cap 101 and the needle shield are removed as has been explained further above. When the needle cover is moved proximally, the needle will protrude from the device and can be introduced into the target tissue.

Further, this figure shows a part of the drive spring holder 115 connected with a needle cover
30 leg 131 and collar tube 123. The collar tube 123 is surrounded along the axis X by the needle cover spring 119. It further shows the drive spring holder 115, the needle cover spring 119 and the collar tube 123.

Figure 2F is a schematic cross-sectional drawing of the assembled drug delivery device 100 in
35 a view from the same direction as in Figure 2E. It is also shown a needle cover leg 131, opposite to the needle cover leg of Figure 2E with respect to the axis X, the syringe 109 and the drive spring 113 next to it. The needle is not shown for the purposes of better illustration. The

drive spring 113 is covered by the plunger rod 111. It is also shown a cross-section of the needle cover spring 119 and the collar 117. It further shows the fixing portion 171 for fixing the drive spring holder 115 to the case 201. It is also shown a part of the plunger rod 111 and the drive spring 113, which is located in the cylindrical cavity of the plunger rod 111. The drive spring abuts a proximal surface of the plunger rod, e.g. near the distal end of the drive spring, and a distal surface of the drive spring holder, e.g. of the drive spring holder disc portion 155.

Figure 3A is a schematic 3D drawing of the collar 117 and the needle cover leg rib 135 of the needle cover 105 in the primed position or state. In this state the drug delivery device 100 is adjusted such that a user can initiate a release process which leads to the injection of a medicament. In other words: When the device is in the primed state, a delivery operation of the device can be initiated. When the user wants to use the device he removes the cap 101 from the case 201 which at the same time removes the protective needle shield 125 from the needle. Once the cap 101 has been removed the needle cover may be moved relative to the collar and the case to trigger the injection. Before triggering the injection, the needle cover, in particular a distal surface thereof, may contact the user's skin and, for triggering, the case is moved in the distal direction. This applies a force to the needle cover 105 which then moves in the proximal direction relative to the collar. While the needle cover moves proximally, the needle may penetrate the skin of the user. The proximal movement of the needle cover activates a release mechanism such that the drive spring 113 is enabled to drive the plunger rod distally relative to the case and the syringe. The primed state is a state which is established by the manufacturer of the drug delivery device 100, so that the device is sold in a condition ready to use and no user priming steps are required.

Before the device is prepared to be in the primed position or state, the device 100 is in a so-called un-primed position or state. In this un-primed state one or more locking mechanisms are in place which ensure that an accidental release of the plunger rod is avoided. A sub-assembly comprising plunger rod, drive spring, collar and/or drive spring holder may be in this position or state already when it is connected with other parts of the device during the assembling process. Therefore, the drive spring may be kept reliably in a tensioned state until the device is brought into the primed state, which is the condition ready to release the plunger rod. Accordingly, the un-primed state may be maintained until the device 100 is completely assembled and the primed position is established for sale and use.

In the presently proposed mechanism, the needle cover may be used for switching from the un-primed state to the primed state. The needle cover 105 is movable axially relative to the case 201 along the longitudinal axis X, in particular in the proximal direction. The collar 117 is axially

and rotationally movable relative to the case 201. The drive spring holder 115 is fixed with the fixing portion 171 to the case 201 and is a member separate from the case 201 but axially and rotationally secured to the case 201. The needle cover leg ribs 135 of the needle cover 105 are in mechanical contact with the ramped collar priming bosses 147 or can be brought into contact with the ramped collar priming bosses 147 when the needle cover 105 is moved proximally when the device is switched from the unprimed state to the primed state, i.e. when the priming operation is performed. In Figure 3A the priming operation has been performed already, i.e. the device is in the primed state ready for performing the delivery operation.

10 The unprimed state is illustrated very schematically by way of Figure 3C. As is depicted, the collar 117 axially abuts the drive spring holder 115. Thus, the force of the drive spring which may also act on the collar, cannot move the collar distally relative to the drive spring holder 115 as the drive spring holder is secured to the case axially and preferably rotationally. The collar 117 is merely represented by one feature, e.g. the collar tongue 145. It should be appreciated, that the axial abutment between the drive spring holder 115 e.g. the drive spring holder ring 167 and the collar may also be effected by a larger surface area of the collar such as the distal rim of the collar circumferentially contacting the drive spring holder, e.g. the drive spring holder ring 167. However, for priming purposes, the key features which of the collar 117 and the drive spring holder 115 are the collar tongue 145 and the drive spring holder sawtooth boss 139, which is why Figure 3C shows these components.

When the needle cover 105 is moved in the proximal direction along the axis X, for priming the device, the collar 117 and the plunger rod 111 (not shown), which is slaved or immovably coupled to the collar as will be explained below, until the plunger rod is released from the collar, are also pushed in the proximal direction along the axis X on account of the engagement of the needle cover with the priming bosses 147, which transfers an axial force and a rotational force to the collar 117 due to the ramps are oblique surfaces of the priming bosses. It should be noted, that, instead of having a plurality of priming bosses, one priming boss 147 may be sufficient. If the collar tongue 145 already angularly abuts the drive spring holder sawtooth boss 139 when the axial and rotational force is imparted to the collar, the movement of the needle cover causes, on account of the block rotational movement, and axial movement of the collar 117 in the proximal direction relative to the case and/or the drive spring holder 115. If there is not yet an angular abutment between, the collar and the drive spring holder, the collar may be moved axially and rotationally relative to the drive spring holder 115 on account of the forces transferred to it via the needle cover and the priming boss. However, independent of whether there is an abutment already when the needle cover in cooperation with the priming boss starts to transfer axial and rotational forces to the collar, after the collar 117 and, particularly, the collar

tongue 145 has cleared axially the drive spring holder sawtooth boss 139, rotation of the collar relative to the drive spring holder is no longer blocked and a rotational movement of the collar 117 relative to the case and the drive spring holder 115 occurs. The axial and rotational movements of the collar are symbolized in Figure 3C by the arrows.

5

The needle cover legs 131 are guided by the drive spring holder rails 157, which are arranged at the outside of the drive spring holder ring portion 167, along the axis X. The drive spring holder 115 is fixed to the front case 121 by the fixing portion. The collar 117 and the plunger rod 111 are held together by the collar beams 141 and its collar prongs 143 which are locked into the notches 151 of the plunger rod 111. When the drive spring holder sawtooth boss 139 is axially overlapping with the collar tongue 145 (see Figure 3C) of the collar 117, the collar 117 is not able to rotate around the axis X in the direction and/or position which is required to release the plunger rod (to the left in Figure 3C) as this rotation is or can be blocked by the collar tongue 145 abutting the sawtooth boss 139. When the needle cover 105 is moved further in the proximal direction and the collar 117 is moved in the proximal direction as well, at some point the collar tongue 145 has axially cleared the drive spring holder sawtooth boss 139 which allows rotational movement in the direction required to release the plunger rod as this rotation is no longer blocked by the drive spring holder sawtooth boss 139. At this stage the collar tongue 145 can no longer abut the drive spring holder sawtooth boss 139, in particular the sawtooth boss surface 173 thereof, and the collar 117 together with the plunger rod 111 are able to rotate around the longitudinal axis X. The force of the drive spring may maintain the collar tongue 145 and the drive spring holder sawtooth boss 139 axially in abutment also in the primed state which has been now achieved and which is, as far as the components depicted in Figure 3C are concerned, schematically illustrated in Figure 3D. The spring force of the drive spring still acts on the collar 117 and tries to move the collar distally relative to the drive spring holder and/or the case. On account of the oblique surface 173 of the sawtooth boss 139 which the collar tongue 145 now abuts, the distally directed force of the drive spring tends to rotate the collar 117 in the direction defined by the sawtooth boss surface 173, which is to the left in Figure 3D. This direction may be the direction in which rotation is required to release the plunger rod for a delivery operation. However, rotation of the collar and the plunger rod, which is slaved to it in the primed state, in that direction may be blocked by another component, preferably a movable component, such as the needle cover 105 which is discussed further below.

Figure 3B is a schematic 3D-drawing of the collar 117, the drive spring holder 115 and the needle cover legs 131 of the needle cover 105 in a primed state or position. When the collar tongue 145 applies a force which originates by the drive spring 113 to the drive spring holder sawtooth boss 139 because of the ramped shape of the sawtooth boss surface 173 of the drive

35

spring holder sawtooth boss 139 this applied force tends to cause or causes a rotation of the collar 117 around the longitudinal axis X, particularly in the direction defined by the ramp, e.g. clockwise as seen from the proximal end.

5 The rotation of the collar 117 is stopped or blocked when the collar firing boss 159 of the collar gets in contact with the needle cover leg rib 135 which overlap in their positions at least partially axially. The collar firing boss 159 of the collar 117 then prevents the collar 117 from rotating further around the longitudinal axis X as the needle cover leg is locked rotationally relative to the housing or case 201 and the collar firing boss 159 abuts the needle cover leg rib 135. Thus, the
10 collar cannot rotate in that direction which it would have to rotate for the delivery operation - in Figure 3B this direction is clockwise as seen from the proximal end of the collar 117 - as this rotation is blocked by the needle cover 105. Starting from the primed position, as outlined above, a delivery operation can be triggered, e.g. via the needle cover which acts as trigger member as will be explained below in more detail. The needle cover reacts a part of the drive
15 spring force which is transferred to it via the collar 117. In the primed position, the collar preferably is in mechanical cooperation with the drive spring holder sawtooth boss 139, e.g. the ramp shaped surface 173 thereof.

The needle cover leg rib 135 may provide an angularly oriented surface which abuts the collar
20 firing boss 159 in the primed position. Thus, the leg rib 135 blocks rotation of the collar 117 to avoid an accidental release of the plunger rod. The needle cover leg rib(s) may have a distally oriented surface which in the primed position abuts a proximally facing surface of the collar. In this way a distal movement of the needle cover relative to the case and the collar may be prevented. The distally facing surface may be a surface of the leg rib 135. The angularly facing
25 surface and the distally facing surface may be implemented by an L-shaped geometry of the leg needle cover leg rib 135 as depicted in Figure 1D, for example.

Figure 4A is a schematic 3D-drawing of the collar 117, the drive spring holder 115 and the
30 needle cover legs 131 of the needle cover 105 after the cap 101 is removed from the case 201 and the delivery of the injection fluid or medicament is initiated. Once the cap 101 is removed the user can press the needle cover 105 in the proximal direction which then moves in the proximal direction along the longitudinal axis X, e.g. along the drive spring holder, such as along the drive spring holder rail 157. The needle cover leg rib 135 is then moved as well in the proximal direction, reaching a point where it does not overlap in its position axially with the collar
35 firing boss 159 such that the collar 117 and the plunger rod 111 are no longer blocked from further rotation. The plunger rod 111 and collar 117 then rotate together on account of the rotational interlock provided by the collar beams. This rotation originates from the force of the

drive spring 113 which acts in the distal direction tends to move the plunger rod 111 distally. As the plunger rod 111 is mechanically connected to the collar 117 the collar 117 is also pushed in the distal direction. The collar 117 can move in the distal direction when the collar tongue 145 is at a rotational position where it abuts the ramp of the drive spring holder sawtooth boss 139.

5 Because of the ramped shape of the drive spring holder sawtooth boss 139 a helical movement of the collar 117 occurs such that the collar 117 rotates around the longitudinal axis X and moves in the distal direction along the longitudinal axis X at the same time. The movement may be helical. As the plunger rod is also axially locked to the collar, the plunger rod also moves helically.

10

Figure 4B is a schematic cross-sectional drawing of the collar 117 being connected with the plunger rod 111. The collar prong 143 of the collar beam 141 interacts with the notch 151 of the plunger rod 111 such that the plunger rod 111 and the collar 117 move together axially and rotationally. In this status the drive spring 113 force is compensated or reacted by the collar

15 beams. The drive spring holder ring 167 of the drive spring holder 115 supports the collar beams 141 radially (although only one beam is depicted two or more than two beams may be provided) such that those are unable to radially flex outwards with respect to the axis X. At the position where the needle cover leg rib 135 no longer blocks the collar firing boss 159, the collar 117 and the plunger rod then rotate together (see Figure 4A). This rotation occurs relative to the

20 drive spring holder 115. This rotation stops at the position where the collar beams 141 can flex outwardly into the drive spring holder grooves 149. Preferably a rotational end stop is provided, e.g. on the drive spring holder, wherein the end stop stops rotation in that position by an angularly directed surface of the end stop abutting an angularly facing surface of the collar or the proximal surface of the drive spring holder and the distal surface of the collar abut.

25

Alternatively or additionally, an axial end stop may be provided which stops the collar 117, e.g. the drive spring holder ring 161. The movement of the collar beams 141 radially outward is caused by the force of the drive spring 113. The collar prongs 143 which are locked into the notches have an oblique surface which is oriented in the proximal direction such that the edge of the notches 151 are pushed under the force of the drive spring 113 towards this oblique

30 surface. The edge of the notches 151 glides in the distal direction along the collar prongs which causes the collar prongs 143 to move radially outward so that the collar beams 141 flex radially outward, preferably elastically. In another embodiment the collar beams 141 during mounting are bent elastically inwardly towards the axis X and covered by the drive spring holder ring 167. The collar beams 141 then continuously apply a force towards the drive spring holder ring 167.

35

Once the collar beams 141 face the drive spring holder grooves 149 they flex outwards into the drive spring holder grooves 149 due to the lack of radial support in this region.

The drive spring holder 115 may react a part of the drive spring force which is transferred to it via the collar beams 141 or an elastic restoring force which tends to disengage the collar beam 141 from the plunger rod 111, e.g. by radially supporting the collar beam. When the collar beam has reached the position of the groove 149 by axial and rotational movement of the collar relative to the drive spring holder, the radial support is removed and the collar beams will disengage the plunger rod. After the collar beams have disengaged the plunger rod, the beams may be biased radially inwardly. That is to say they tend to move inwardly (again). The collar beams, in particular the prongs, may abut an exterior surface of the plunger rod after the disengagement, e.g. on account of an elastic restoring force which tends to move the collar beams inwardly.

Figure 5A is a schematic cross-sectional drawing of the collar beams 141 when having flexed radially outwards. When the collar beams 141 flex outwardly into the grooves 149 the collar 117 is not anymore connected via the collar beams 141 and the collar prongs 143 to the plunger rod 111 and the plunger rod 111 can progress in the distal direction under the force of the drive spring relative to the collar. The drive spring holder 115 comprises a radial outward step or flange, e.g. formed by the drive spring holder ring 167, wherein the radial outward step or flange has an opening wherein the collar beams 141 extend into the interior of the drive spring holder 115 through the opening and/or the radial outward step or flange defines an end stop surface for the collar 117 which stops the axial and/or rotational movement of the collar 117 when the collar beams 141 are moved towards drive spring holder 115.

Figure 5B is a schematic cross-sectional drawing of a section of a part of the drug delivery device 100. The plunger rod 111 and the collar 117 are no longer held together by the collar beams 141. The plunger rod 111 is free to advance in the distal direction along the axis X under the force of the drive spring 113 for delivering the medicament from the syringe 109. The drive spring force, in the primed state, may be greater than or equal to any one of the following values: 20N, 25N, 30N, 45N or even higher. The plunger rod 111 may slide along the collar beams 141 during delivery. The drive spring 113 load is resolved through supporting the syringe 109 at its shoulder, either on a separate syringe holder or on a body inner tube or inner portion. The needle cover spring may bias the collar proximally relative to the drive spring holder. However, the collar beams expediently block the proximal movement as they are outwardly deflected, preferably elastically, and may react the bias force, such as either by mechanical contact with a radial surface, e.g. the one of the plunger rod, and/or by mechanical contact with a distally facing surface, e.g. a surface of the drive spring holder.

Figure 5C is a schematic cross-sectional drawing of the drug delivery device 100 in a condition close to the end of the delivery operation. Consequently, the collar beams 141 have cleared the plunger rod 111 axially and the beams 141 can flex inwardly again as depicted. As the collar beams do no longer block the proximal movement of the collar, the movement is now allowed.

5 The needle cover spring 119 drives the collar 117 in the proximal direction along the axis X. The collar may hit an interior surface of the device, e.g. a surface of the case 201. This impact may generate a noise, e.g. upon contact with the rear case 121. In other words, the collar beams 141 of the collar 117 return to their original state when the proximal end of the plunger rod 111 has moved in front of them. The proximal end of the plunger rod 111 passes the collar beams

10 141 of the collar 117, allowing them to return to their original, e.g. unstressed or less stressed, state. The end of the dose noise is produced by the collar circular edge 161 of the collar 117 contacting ribs of the rear case 121 after it is pushed in the proximal direction by the needle cover spring 119. Therefore, in the present device, the needle cover spring serves two

15 purposes, i.e. to bias the needle cover (see also the further discussions below) and to drive a feedback mechanism.

Figure 6A is a schematic drawing of a section of the drug delivery device 100 at or near the distal end D along the axis X. It shows a part of the plunger rod 111 and of the drive spring 113 in the region of the front case 107. For purposes of better illustration, the needle is not shown.

20 The needle may be provided at the distal end of the syringe 109, e.g. as a staked needle. After the plunger rod 111 has reached its end position relative to the syringe 109, e.g. when the stopper 129 contacts an inner distal end wall of the syringe barrel 127, the delivery or injection operation is completed. Then the user may withdraw the device from the injection site. In order to cover the needle, the needle cover 105 may be moved distally relative to the housing or case

25 under the action of the needle cover spring 119, expediently until the needle cover reaches an end position relative to the case or housing which may comprise the front case 107 and the rear case 121. However, other housing structures - not necessarily involving a front case and a rear case - are also possible such as a unitary housing or case. In the end position, the needle cover is expediently prevented from being moved proximally relative to the housing. In this way, the

30 needle remains covered by the needle cover and the risk of needle stick injuries is reduced. The end position may be distally offset from a position the needle cover has before it is moved proximally relative to the case in the proximal direction in order to trigger or initiate the delivery operation. This will be discussed further below. Figure 6A shows the end position of the needle cover after a delivery operation has been performed and the needle cover 105 has been

35 removed from the user's skin.

In order to lock the needle cover 105 against proximal movement relative to the housing or the case, particularly in the end position after the delivery operation has been performed, the needle cover has one or a plurality of needle cover lock arms 163. In the depicted embodiment, two arms are provided. However, more than two arms may be provided as well. In case there are a plurality of arms 163 they are preferably evenly distributed in the angular direction. The needle cover lock arms are expediently oriented axially, particularly proximally. A free end of the needle cover lock arms 163 may face in the proximal direction. The needle cover lock arms 163 may be arranged to abut or abut a distally facing surface of the case or housing or a component which is at least axially, but preferably axially and rotationally, secured relative to the housing or case.

5 In the position depicted in Figure 6A, the proximally directed surface of the needle cover lock arm 163 is formed by the surface of a needle cover ramp or lock feature 165. The ramp or feature 165 may protrude inwardly and/or radially relative to an adjacent portion of the needle cover lock arm 163. The needle cover lock feature 165 abuts or is arranged to abut a distally facing surface of an inner portion 600 of the device. The inner portion may define an interior

10 region. It may have a tube-like or sleeve-like shape. The inner portion 600 may be dimensioned to receive a section of the syringe 100 within its interior. Other than depicted, the inner portion 600 may provide a bearing surface, such as a proximally facing surface, for mechanical contact with the syringe, e.g. a neck portion thereof. Accordingly, the syringe may be retained in the case by the inner portion 600. The inner portion may be a holder portion or a retaining portion

15 for the syringe 109. The inner portion 600 may be dimensioned such that the syringe 109 bears with a distally facing surface against a proximally facing surface of the portion 600, preferably a glass surface and/or a surface of a neck portion of the syringe barrel, which has a reduced diameter as compared to the portion of the syringe barrel where the stopper is guided (not explicitly shown). The inner portion has an opening, e.g. a distal opening, through which, for

20 example, a section of the syringe and/or the needle of the syringe, which may be staked to the syringe barrel, may extend. In the section of the arms 163 which is arranged distally from the needle cover lock features 165, the arms may define an inner diameter which is greater than the outer diameter of the inner portion 600. The diameter defined between the ends of the features 165 may be smaller than the outer diameter of the inner portion but preferably greater than the

25 inner diameter of the inner portion. This ensures that the distal surface of the wall 601 of the inner portion 600 may be contacted by the needle cover lock features 165 to block proximal movement of the needle cover 105 and that the arms 163 may, in an initial position, extend along the inner portion, when the features 165 are proximally offset from a distal end of the inner portion 600 as will become apparent from the further explanations below.

35

The inner portion 600 may be radially spaced apart from an inner wall of a portion of the case which delimits the interior of the device from the exterior. Accordingly, a channel, e.g. an axially

extending channel, which may be continuous in the circumferential direction, may be formed between the portion 600 and an inner wall of the case or housing. The channel may be configured to receive a section of the needle cover, e.g. when the needle cover is arranged in the initial position and/or moved proximally to trigger the delivery operation.

5

Laterally, in an outer surface of the inner portion 600, one or a plurality of guide slots 602 may be formed. The guide slots may be arranged and configured to guide the lock arms 163 axially, e.g. by receiving the needle cover lock features 165. The lock features 165 may be received in the guide slots 602 when the needle cover is in its initial position, e.g. that position from which the delivery operation may be triggered by moving the needle cover proximally. As is depicted in Figure 6A, a distal surface of the needle cover ramp or lock feature 165 is inclined relative to the longitudinal axis X. Especially, it may be inclined in the distal direction such that, as seen in the distal direction, it includes an acute angle with the longitudinal axis X. As opposed to this, the proximally facing surface of the needle cover lock feature 165 may be, e.g. predominantly or entirely, radially oriented. For example, the proximal surface may run perpendicular relative to the longitudinal axis. Thus, the proximal surface of the lock features 165 is suitable to block proximal movement by cooperating with the distal surface of the inner portion. The distal surface of the lock features is suitable, e.g. in cooperation with a proximal end wall of the guide slot 602 in the inner portion 600, to deflect the locking arms 163 radially outwardly, when the needle cover moves distally in order to allow axial movement of the locking feature 165 beyond the initial position in a distal direction relative to the inner portion 600. In this way, the needle cover may assume its locking position, where proximal movement is no longer allowed or at least prevented such that a tip of the needle is not exposed and cannot be touched by the user.

The respective needle cover lock arm 163, which expediently has a proximally facing free end, may be flexibly, e.g. elastically, connected to the remainder of the needle cover. The arm 163 may be resiliently displaceable relative to the longitudinal axis, e.g. outwardly. The resilient bias generated by the elastic displacement of the arm may move the arm 163 and the needle cover lock feature 165 inwardly again after the feature has cleared the inner portion. The needle cover lock arm may be pivotable relative to the needle cover. The ability to pivot may be provided by way of a hinge portion 175 in the needle cover which has a reduced thickness which is located in a region of the arm 163 remote from the free end. The hinge portion may be a film hinge portion. However, already the presence of distinct arms may provide for enough resiliency or flexibility for the present purposes and the hinge portion 175, though advantageous, may be dispensed with.

35

The needle cover lock arm 163 may be axially oriented, e.g. parallel to the axis X. Preferably, the needle cover lock arm is axially oriented in both positions, the initial position and the end position. The same may hold for an intermediate position, i.e. a position, where the needle cover is proximally displaced relative to the initial position for triggering the delivery operation.

5

The respective needle cover lock arm 163 is connected to the remainder of the needle cover 105 via a connecting portion 177. The connecting portion 177 may extend circumferentially and, particularly, may have the shape of a sleeve. The connecting portion 177 may be radially inwardly offset from an inner wall of the front section 133 of the needle cover 105. In this way, there may be a radial clearance between the connecting portion 177 and inner surface.

10

Alternatively or additionally, a distance may be present in the radial direction between the lock arm 163 and an inner surface of the front section 133 of the needle cover. This distance allows radial flexibility for radial deflection of the arm 163 in the outward direction during the movement of the needle cover into the end position and/or radially inward movement, e.g. due to its intrinsic resiliency, back into a radial position where the arm is arranged to abut the distally facing surface of the inner portion such as a surface of wall 601. The connecting portion 177 may be axially oriented. The connecting portion 177 may be connected to the front section 133 of the needle cover which defines the outer lateral surface of the needle cover via a further connecting portion 179, which preferably extends in the radial direction, e.g. outwardly.

15

20

Connecting portion 179 may be provided at the end of the axial connecting portion 177 remote from the needle cover lock arms 163. The needle cover lock arm 163 may be restricted to the interior of the needle cover, especially its front section 133. The connecting portion 179 may provide a bearing surface for the needle cover with which the needle cover is configured to bear against the skin of a user of the drug delivery device during the delivery operation.

25

As compared to needle covers which use obliquely oriented fingers on an outer surface of the needle cover which interact with an inner surface of the housing for locking the needle cover in the end position after the delivery operation, the present construction with the needle cover lock arms 163 which are arranged on the interior and not on the exterior facilitates the provision of a syringe with a shorter needle. This is, because the axial extension of the slanted needle cover lock arms does not have to be taken into account when designing the needle cover. Moreover, as the needle cover lock arms are provided in the interior, they are hidden and cannot be manipulated in an attempt to reuse the device or uncover the needle again. Providing syringes with shorter needles may facilitate modifying an existing device architecture to accommodate syringes of higher volumes such as a volume greater than or equal to 2 mL, or greater than or equal to 2.5 mL or greater than or equal to 3 mL without having to extend the length of the device and/or its diameter considerably.

30

35

Aside from the shorter needle cover, the collar may assist in avoiding a considerable increase in the dimension, especially lengthwise, due to use of a higher volume syringe. Drive features, e.g. bosses, which may be required on the plunger rod, e.g. its proximal end, can be dispensed with
5 as the collar 117 governs the rotational and axial movement of the plunger rod until the plunger rod is released from the collar. Thus, there is no need to provide the plunger rod with profiled surface structures which guide the plunger rod rotationally. The axial space which is saved by using the collar for the plunger rod release can be accommodated by a portion of the syringe.

10

As discussed above, the internally arranged needle cover lock arms 163 prevent proximal movement of the needle cover 105. Distal movement of the needle cover is prevented by a proximal surface which is axially secured to the housing abutting a distal surface of the needle cover such as a distal surface delimiting the needle cover cut out 137 as depicted in Figure 6B
15 which is discussed below.

20

Figure 6B is a schematic drawing of a section of the drug delivery device 100 at the distal end D along the axis X. The view is rotated by 90 degrees around the axis X as compared to the view of Figure 6A. As is apparent from Figure 6B, the needle cover cutouts 137 of the needle cover legs 131 of the needle cover 105 are guided by the serrate sections 205 of the front case 121 or another end stop secured to the case. When the proximal end of the cutouts abuts the sections 205, the needle cover is blocked from being displaced further in the distal direction due to the force applied by the needle cover spring 119. Thus, at least a portion of the needle cover spring force or the entire remaining force may be reacted by the case or housing.

25

The different positions of the needle cover with respect to the housing or case are explained in more detail below.

30

Figure 7A is a schematic drawing of a section of the drug delivery device 100 at the distal end D showing the cap 101. The device is in a condition prior to priming, i.e. in the unprimed state. In this state, the needle cover lock arms 163 and the lock features 165 may be distally offset from the guide slots 602.

35

The arrangement in Figure 7A prevents unintentional proximal movement of the needle cover and, consequently, unintentional priming of the device. In order to enable priming, the needle cover lock arms 163 have to be moved radially outwardly such that they clear the inner portion.

When they have cleared the inner portion, the arms 163 may be moved axially relative to the inner portion 600 such that the needle cover 105 may perform a priming movement as has been explained further above already. When the needle cover 105 is displaced proximally relative to the case and the inner portion, the arms or the needle cover lock features 165 may be moved to
5 engage the corresponding guide slots 602, which have been discussed previously already.

From the unprimed position in Figure 7A, it is advantageous, if at least the radial and/or outward movement of the needle cover lock arms 163 can be effected by way of the cap 101. In other words, a mechanical interaction between the cap 101 and the needle cover lock arms 163 or
10 the features 165 may be used to displace the needle cover lock arms 163 radially, especially outwardly. The interaction can be effected while the cap is attached to the case are at least moved towards the case so as to cover its distal end and, preferably, the needle and/or the rigid needle shield. When the cap 101 is attached or moved towards the case 107, a proximally facing surface of an inner tube section 181 of the cap or another component connected to the
15 cap may engage the distally facing surface (distal surface) of the needle cover lock feature 165. This feature is oblique relative to the axis, which is why the axial movement of the cap may be used to generate irregular of movement by abutting the distal surface of the needle cover lock feature

20 A needle shield grabber (not shown in this representation, see 103 in Figure 1A) may be received in the inner tube 181 of the cap. The needle shield grabber may interlock with the needle shield, e.g. a rigid needle shield, of the syringe in order to remove the needle shield, when the cap is removed before the delivery operation is conducted.

25 The needle cover 105 may be moved axially in the proximal direction until its proximal movement is blocked, e.g. by the arms 163 or the features 165 hitting the distal surface of the inner portion. Now, further axial movement of the needle cover in the proximal direction is prevented. As the cap is moved further in the proximal direction towards its end position relative to the case, on account of the obliqueness of the distally facing surface of the needle cover lock
30 feature 165, the feature 165 and the associated arm 163 may be deflected radially outwardly, such as towards an inner wall of the needle cover 105. Thereafter, the needle cover 105 may be moved proximally relative to the case or housing. Then, the features 165 may engage the guide slots 602. This movement of the needle cover may be effected by way of an assembly tool which can be introduced through apertures in the cap through which the needle cover 105 can
35 be contacted. However, it is also conceivable that the axial movement of the needle cover into its initial position in which the needle cover lock features 165 engage the guide slots 602 occurs on account of the movement of the cap 101 relative to the case into its end position. In this

case, the radial movement of the needle cover lock features may be effected by the portion of the cap being introduced into the interior of the needle cover. In this case, an axial support is not required to radially displace the needle cover lock arms. Whether or not the support is advisable or used for the radial displacement of the arms 163 may depend on the force required to displace the arms radially.

Figure 7A shows the situation during the proximal movement of the cap 101 before the arms 163 are deflected radially outwardly. When the cap 101 and front case 107 are pressed together, i.e. the movement for attaching the cap is performed, the distal end of the inner portion 600 which comprises a front wall 601 presses against the needle cover ramps or lock features 165 on the needle cover lock arms 163 of the needle cover 105. The force exerted on the cap 101 flexes the needle cover lock arms 163 outwardly.

Figure 7B is a schematic drawing of a section of the drug delivery device 100 at the distal end D showing the device in the primed position or state. Here, it can be seen that the needle cover lock arms 163 have cleared the front wall 601 of the inner portion 600 and engage the guide slots 602. As depicted in this Figure, the device may be in a condition it has when the user receives the device, as the priming operation is expediently carried out by the manufacturer.

Figure 7C is a schematic drawing of a section of the drug delivery device 100 at the distal end D showing the front case 107 and the needle cover 105 in a condition, when the needle cover 105 has been moved proximally so as to trigger the delivery operation. The needle cover 105 may be pushed in the direction towards the proximal end P by the user. As can be seen, the needle cover lock arms 163 and, in particular, the needle cover lock features 165 overlap axially with and/or are radially offset from the syringe 109. Figure 7C shows the situation when, starting from Figure 7B, the cap 101 has been removed - optionally together with the needle shield 125 - in order to prepare the device for the delivery operation. Thereafter, the needle cover may be moved into the proximal direction to trigger the delivery operation. While the needle cover is moved from the position depicted in Figure 7B into to the position depicted in Figure 7C, the arms 163 and the needle cover lock features 165 are not radially deflected. Rather the arms stay axially oriented parallel to the axis X which runs through the proximal and distal ends. From Figure 7C it is apparent that the needle cover 105 has been moved proximally and the needle cover lock features 165 have been displaced proximally within the associated guide slot 602 into an end position. The end position of the needle cover 105 relative to the case may be defined by an abutment between a proximally facing surface of the needle cover and a distally facing surface of the housing, e.g. by an abutment between the front section 133 of the needle

cover 105 and a distally facing end surface proximally delimiting the channel in the case which receives the front section 133 during the proximal movement of the needle cover 105.

As is depicted in Figure 7C, the needle shield 125 has been removed. The needle is not explicitly shown for illustration purposes. However, it is, nevertheless, preferably present. Also, the inner portion 600, as discussed previously already, may support the syringe 109 such that the syringe 109 cannot be moved distally relative to the housing or case.

After the injection operation or delivery operation has been performed, the needle cover 105 may be moved towards the end position and into the imposition by way of the needle cover spring as has already been discussed previously.

Figure 7D is a schematic drawing of a section of the drug delivery device 100 at the distal end D showing the front case 107 and the needle cover 105 in an end position after dose delivery has been completed and the user has removed the device from the skin. As compared to the position in Figure 7C, the needle cover 105 has advanced forward, i.e. distally, due to the action of the needle cover spring 119. The needle cover lock arms 163 ensure needle safety by pressing against the front wall 601 by way of the features 165. Distal movement of the needle cover is prevented by the features 205 abutting a distally facing surface of the needle cover such as the end surface of the needle cover cutout 137.

Figures 8A and 8B illustrate an alternative to the needle cover lockout mechanism which has been described above, using the needle cover lock arms 163. The needle cover lock mechanism could also be provided in addition to the mechanism discussed in conjunction with figures 6A through 7D.

As has been discussed previously the collar or plunger rod release member 117 is moved proximally after the plunger rod has been released from the collar. Then the drive spring force is no longer transferred to the collar 117. When moving proximally, the collar 117 moves towards an inner surface of the case or housing. The proximal movement of the collar 117 is driven by the needle cover spring 119, which is operatively coupled between the needle cover 105 and the collar, e.g. by abutting the distal surface of flange 161. In the previously described embodiment, the collar may move purely axially in the proximal direction. It is, however, possible to use force of the needle cover spring to rotate the collar 117, e.g. to establish a needle cover lock by means of the collar in order to lock the needle cover 105 against proximal movement in the end position. The end position may be distally offset from the initial position.

Figure 8A shows the collar 117. As opposed to the previous representation, the collar has a feature 300 which has an oblique or ramp surface 301 which extends in the angular direction. The surface 301 can be arranged to interact with a feature which is axially secured relative to the case, such as a feature (not explicitly shown) within the case or a feature (not explicitly shown) on the drive spring holder 115 during the proximal movement of the collar 117. In this way, due to the interface which is formed between the ramp surface 301 and the case or drive spring holder, the collar may be rotated relative to the case and/or the drive spring holder 115. The rotation may be in the same direction as the one, which was performed during priming and/or release of the plunger rod. Alternatively, the rotation may be in the opposite direction.

Due to the rotation, a feature on the collar such as a needle cover lock feature 302 provided on the collar may be rotated into a position where it angularly and radially overlaps with a proximally facing surface associated with the needle cover, e.g. a proximal surface of the needle cover legs 131. In this position, the lock feature 302 may abut or be arranged to abut the needle cover 105. As the collar, in its proximal end position cannot be moved proximally anymore, e.g. as it abuts a distally facing surface of the case, the abutment between the needle cover and the needle cover lock feature 302 on the collar prevents proximal movement of the needle cover and, accordingly, provides a needle cover lockout suitable to lock the needle cover in its end position against proximal movement relative to the case or housing.

The terms “drug” or “medicament” are used synonymously herein and describe a pharmaceutical formulation containing one or more active pharmaceutical ingredients or pharmaceutically acceptable salts or solvates thereof, and optionally a pharmaceutically acceptable carrier. An active pharmaceutical ingredient (“API”), in the broadest terms, is a chemical structure that has a biological effect on humans or animals. In pharmacology, a drug or medicament is used in the treatment, cure, prevention, or diagnosis of disease or used to otherwise enhance physical or mental well-being. A drug or medicament may be used for a limited duration, or on a regular basis for chronic disorders.

As described below, a drug or medicament can include at least one API, or combinations thereof, in various types of formulations, for the treatment of one or more diseases. Examples of API may include small molecules having a molecular weight of 500 Da or less; polypeptides, peptides and proteins (e.g., hormones, growth factors, antibodies, antibody fragments, and enzymes); carbohydrates and polysaccharides; and nucleic acids, double or single stranded DNA (including naked and cDNA), RNA, antisense nucleic acids such as antisense DNA and RNA, small interfering RNA (siRNA), ribozymes, genes, and oligonucleotides. Nucleic acids

may be incorporated into molecular delivery systems such as vectors, plasmids, or liposomes. Mixtures of one or more drugs are also contemplated.

5 The drug or medicament may be contained in a primary package or “drug container” adapted for use with a drug delivery device. The drug container may be, e.g., a cartridge, syringe, reservoir, or other solid or flexible vessel configured to provide a suitable chamber for storage (e.g., short- or long-term storage) of one or more drugs. For example, in some instances, the chamber may be designed to store a drug for at least one day (e.g., 1 to at least 30 days). In some instances, the chamber may be designed to store a drug for about 1 month to about 2 years. Storage may
10 occur at room temperature (e.g., about 20°C), or refrigerated temperatures (e.g., from about -4°C to about 4°C). In some instances, the drug container may be or may include a dual-chamber cartridge configured to store two or more components of the pharmaceutical formulation to-be-administered (e.g., an API and a diluent, or two different drugs) separately, one in each chamber. In such instances, the two chambers of the dual-chamber cartridge may
15 be configured to allow mixing between the two or more components prior to and/or during dispensing into the human or animal body. For example, the two chambers may be configured such that they are in fluid communication with each other (e.g., by way of a conduit between the two chambers) and allow mixing of the two components when desired by a user prior to dispensing. Alternatively or in addition, the two chambers may be configured to allow mixing as
20 the components are being dispensed into the human or animal body.

The drugs or medicaments contained in the drug delivery devices as described herein can be used for the treatment and/or prophylaxis Y of many different types of medical disorders. Examples of disorders include, e.g., diabetes mellitus or complications associated with diabetes
25 mellitus such as diabetic retinopathy, thromboembolism disorders such as deep vein or pulmonary thromboembolism. Further examples of disorders are acute coronary syndrome (ACS), angina, myocardial infarction, cancer, macular degeneration, inflammation, hay fever, atherosclerosis and/or rheumatoid arthritis. Examples of APIs and drugs are those as described in handbooks such as Rote Liste 2014, for example, without limitation, main groups 12 (anti-
30 diabetic drugs) or 86 (oncology drugs), and Merck Index, 15th edition.

Examples of APIs for the treatment and/or prophylaxis Y of type 1 or type 2 diabetes mellitus or complications associated with type 1 or type 2 diabetes mellitus include an insulin, e.g., human insulin, or a human insulin analogue or derivative, a glucagon-like peptide (GLP-1), GLP-1
35 analogues or GLP-1 receptor agonists, or an analogue or derivative thereof, a dipeptidyl peptidase-4 (DPP4) inhibitor, or a pharmaceutically acceptable salt or solvate thereof, or any mixture thereof. As used herein, the terms “analogue” and “derivative” refers to a polypeptide

which has a molecular structure which formally can be derived from the structure of a naturally occurring peptide, for example that of human insulin, by deleting and/or exchanging at least one amino acid residue occurring in the naturally occurring peptide and/or by adding at least one amino acid residue. The added and/or exchanged amino acid residue can either be codable amino acid residues or other naturally occurring residues or purely synthetic amino acid residues. Insulin analogues are also referred to as "insulin receptor ligands". In particular, the term „derivative" refers to a polypeptide which has a molecular structure which formally can be derived from the structure of a naturally occurring peptide, for example that of human insulin, in which one or more organic substituent (e.g. a fatty acid) is bound to one or more of the amino acids. Optionally, one or more amino acids occurring in the naturally occurring peptide may have been deleted and/or replaced by other amino acids, including non-codeable amino acids, or amino acids, including non-codeable, have been added to the naturally occurring peptide.

Examples of insulin analogues are Gly(A21), Arg(B31), Arg(B32) human insulin (insulin glargine); Lys(B3), Glu(B29) human insulin (insulin glulisine); Lys(B28), Pro(B29) human insulin (insulin lispro); Asp(B28) human insulin (insulin aspart); human insulin, wherein proline in position B28 is replaced by Asp, Lys, Leu, Val or Ala and wherein in position B29 Lys may be replaced by Pro; Ala(B26) human insulin; Des(B28-B30) human insulin; Des(B27) human insulin and Des(B30) human insulin.

Examples of insulin derivatives are, for example, B29-N-myristoyl-des(B30) human insulin, Lys(B29) (N- tetradecanoyl)-des(B30) human insulin (insulin detemir, Levemir®); B29-N-palmitoyl-des(B30) human insulin; B29-N-myristoyl human insulin; B29-N-palmitoyl human insulin; B28-N-myristoyl LysB28ProB29 human insulin; B28-N-palmitoyl-LysB28ProB29 human insulin; B30-N-myristoyl-ThrB29LysB30 human insulin; B30-N-palmitoyl- ThrB29LysB30 human insulin; B29-N-(N-palmitoyl-gamma-glutamyl)-des(B30) human insulin, B29-N-omega-carboxypentadecanoyl-gamma-L-glutamyl-des(B30) human insulin (insulin degludec, Tresiba®); B29-N-(N-lithocholyl-gamma-glutamyl)-des(B30) human insulin; B29-N-(omega-carboxyheptadecanoyl)-des(B30) human insulin and B29-N-(omega-carboxyheptadecanoyl) human insulin.

Examples of GLP-1, GLP-1 analogues and GLP-1 receptor agonists are, for example, Lixisenatide (Lyxumia®), Exenatide (Exendin-4, Byetta®, Bydureon®, a 39 amino acid peptide which is produced by the salivary glands of the Gila monster), Liraglutide (Victoza®), Semaglutide, Taspoglutide, Albiglutide (Syncria®), Dulaglutide (Trulicity®), rExendin-4, CJC-1134-PC, PB-1023, TTP-054, Langlenatide / HM-11260C, CM-3, GLP-1 Eligen, ORMD-0901, NN-9924, NN-9926, NN-9927, Nodexen, Viador-GLP-1, CVX-096, ZYOG-1, ZYD-1, GSK-

2374697, DA-3091, MAR-701, MAR709, ZP-2929, ZP-3022, TT-401, BHM-034, MOD-6030, CAM-2036, DA-15864, ARI-2651, ARI-2255, Exenatide-XTEN and Glucagon-Xten.

5 An examples of an oligonucleotide is, for example: mipomersen sodium (Kynamro®), a cholesterol-reducing antisense therapeutic for the treatment of familial hypercholesterolemia.

Examples of DPP4 inhibitors are Vildagliptin, Sitagliptin, Denagliptin, Saxagliptin, Berberine.

10 Examples of hormones include hypophysis hormones or hypothalamus hormones or regulatory active peptides and their antagonists, such as Gonadotropine (Follitropin, Lutropin, Choriongonadotropin, Menotropin), Somatotropine (Somatotropin), Desmopressin, Terlipressin, Gonadorelin, Triptorelin, Leuprorelin, Buserelin, Nafarelin, and Goserelin.

15 Examples of polysaccharides include a glucosaminoglycane, a hyaluronic acid, a heparin, a low molecular weight heparin or an ultra-low molecular weight heparin or a derivative thereof, or a sulphated polysaccharide, e.g. a poly-sulphated form of the above-mentioned polysaccharides, and/or a pharmaceutically acceptable salt thereof. An example of a pharmaceutically acceptable salt of a poly-sulphated low molecular weight heparin is enoxaparin sodium. An example of a hyaluronic acid derivative is Hylan G-F 20 (Synvisc®), a sodium hyaluronate.

20 The term “antibody”, as used herein, refers to an immunoglobulin molecule or an antigen-binding portion thereof. Examples of antigen-binding portions of immunoglobulin molecules include F(ab) and F(ab')₂ fragments, which retain the ability to bind antigen. The antibody can be polyclonal, monoclonal, recombinant, chimeric, de-immunized or humanized, fully human, 25 non-human, (e.g., murine), or single chain antibody. In some embodiments, the antibody has effector function and can fix complement. In some embodiments, the antibody has reduced or no ability to bind an Fc receptor. For example, the antibody can be an isotype or subtype, an antibody fragment or mutant, which does not support binding to an Fc receptor, e.g., it has a mutagenized or deleted Fc receptor binding region. The term antibody also includes an 30 antigen-binding molecule based on tetravalent bispecific tandem immunoglobulins (TBTI) and/or a dual variable region antibody-like binding protein having cross-over binding region orientation (CODV).

35 The terms “fragment” or “antibody fragment” refer to a polypeptide derived from an antibody polypeptide molecule (e.g., an antibody heavy and/or light chain polypeptide) that does not comprise a full-length antibody polypeptide, but that still comprises at least a portion of a full-length antibody polypeptide that is capable of binding to an antigen. Antibody fragments can

comprise a cleaved portion of a full length antibody polypeptide, although the term is not limited to such cleaved fragments. Antibody fragments that are useful in the present disclosure include, for example, Fab fragments, F(ab')₂ fragments, scFv (single-chain Fv) fragments, linear antibodies, monospecific or multispecific antibody fragments such as bispecific, trispecific, 5 tetraspecific and multispecific antibodies (e.g., diabodies, triabodies, tetrabodies), monovalent or multivalent antibody fragments such as bivalent, trivalent, tetravalent and multivalent antibodies, minibodies, chelating recombinant antibodies, tribodies or bibodies, intrabodies, nanobodies, small modular immunopharmaceuticals (SMIP), binding-domain immunoglobulin fusion proteins, camelized antibodies, and VHH containing antibodies. Additional examples of 10 antigen-binding antibody fragments are known in the art.

The terms "Complementarity-determining region" or "CDR" refer to short polypeptide sequences within the variable region of both heavy and light chain polypeptides that are primarily responsible for mediating specific antigen recognition. The term "framework region" refers to 15 amino acid sequences within the variable region of both heavy and light chain polypeptides that are not CDR sequences, and are primarily responsible for maintaining correct positioning of the CDR sequences to permit antigen binding. Although the framework regions themselves typically do not directly participate in antigen binding, as is known in the art, certain residues within the framework regions of certain antibodies can directly participate in antigen binding or 20 can affect the ability of one or more amino acids in CDRs to interact with antigen.

Examples of antibodies are anti PCSK-9 mAb (e.g., Alirocumab), anti IL-6 mAb (e.g., Sarilumab), and anti IL-4 mAb (e.g., Dupilumab).

25 Pharmaceutically acceptable salts of any API described herein are also contemplated for use in a drug or medicament in a drug delivery device. Pharmaceutically acceptable salts are for example acid addition salts and basic salts.

Those of skill in the art will understand that modifications (additions and/or removals) of various 30 components of the APIs, formulations, apparatuses, methods, systems and embodiments described herein may be made without departing from the full scope and spirit of the present concepts, which encompass such modifications and any and all equivalents thereof.

Reference numerals

	D	Distal end
	P	Proximal end
5	X	Longitudinal axis
	100	Drug delivery device
	101	Cap
	103	Grabber
	105	Needle cover
10	107	Front case
	109	Syringe
	111	Plunger
	113	Drive spring
	115	Drive spring holder
15	117	Collar
	119	Needle cover spring
	121	Rear case
	123	Collar tube
	125	Protective needle shield
20	127	Syringe barrel
	129	Stopper
	131	Needle cover leg
	133	Front section
	135	Needle cover leg rib
25	137	Needle cover cutout
	139	Drive spring holder sawtooth boss
	141	Collar beam
	143	Collar prong
	145	Collar tongue
30	147	Collar priming boss
	149	Drive spring holder groove
	151	Notch
	153	Drive spring holder arm
	155	Drive spring holder disc
35	157	Drive spring holder rail / slots
	159	Collar firing boss
	161	Collar circular edge

	163	Needle cover lock arm
	165	Needle cover ramp / Needle cover lock feature
	167	Drive spring holder ring
	169	Drive spring holder cavity
5	171	Fixing portion
	173	Sawtooth boss surface
	175	Hinge portion
	177	Connecting portion
	179	Connecting portion
10	181	Inner tube
	201	Case
	203	Window
	205	Serrate section
	300	Feature
15	301	ramp surface
	302	Needle cover lock feature
	600	inner portion
	601	Front wall
	602	Guide slot
20		

Claims

- 5 1. Drive arrangement for a drug delivery device (100), the drive arrangement comprising:
- a housing (201) having a proximal end and a distal end, a longitudinal axis (X) extending between the proximal end and the distal end,
 - a plunger rod (111), which is arranged in the housing (201) and movable relative to the housing (201),
 - 10 - a drive unit (113) which is arranged to bias the plunger rod (111) to move in the distal direction, i.e. away from the proximal end,
 - a plunger rod release member (117), which comprises at least one plunger rod release feature (141) which is arranged to engage a retention feature (151) of the plunger rod (111), wherein
 - 15 - the plunger rod release member (117) is movable relative to the housing (201) from a first position into a second position, wherein, in the first position, the plunger rod release feature (141) engages the retention feature (151), wherein, when the plunger rod release feature (141) engages the retention feature (151), the plunger rod (111) is prevented from moving relative to the plunger rod release member (117), and wherein,
 - 20 - in the second position, the plunger rod release feature (141) is disengaged from the retention feature (151), thereby allowing the plunger rod (111) to move in the distal direction under the force of the drive unit (113).
2. Drive arrangement according to claim 1, wherein, in the first position, the plunger rod release feature (141) is radially supported and, in the second position, the radial support is removed to allow a radial movement of the plunger rod release feature (141) relative to the retention feature (151) such that the plunger rod release feature (141) disengages the retention feature (151).
3. Drive arrangement according to any one of the preceding claims, wherein
- 30 a) the plunger rod (111) is rotationally secured relative to the plunger rod release member (117) by the plunger rod release feature (141) interacting with the retention feature (151) in the first position and wherein the movement from the first position to the second position involves rotational movement of the plunger rod release member (117) and the plunger rod relative to the housing (201) and/or
 - 35 b) the plunger rod (111) is axially secured relative to the plunger rod release member (117) by the plunger rod release feature (141) interacting with the retention feature (151) in the first position and wherein the movement from the first position to the second position involves axial

movement of the plunger rod release member (117) and the plunger rod (111) relative to the housing.

4. Drive arrangement according to any one of the preceding claims, wherein the movement of the plunger rod (111) and the plunger rod release member (117) from the first position to the second position is a helical movement relative to the housing.
5. Drive arrangement according to any one of the preceding claims, wherein a deepening (149) is arranged in the housing (201), wherein, in the first position, the plunger rod release feature (141) is angularly and/or axially offset from the deepening (149), and wherein, in the second position, the plunger rod release feature (141) is received within the deepening (149).
6. Drive arrangement according to any one of the preceding claims, wherein, in the first position, the engagement between the plunger rod release feature (141) and the retention feature (151) reacts the force of the drive unit (113), which is pre-stressed.
7. Drive arrangement according to any one of the preceding claims, wherein in the first position, a rotational movement of the plunger rod release member (117) is blocked by a blocking interface (135) established between the plunger rod release member (117) and a moveable trigger member (105), wherein the trigger member (105) is movable to release the blocking, preferably the movable trigger member (105) is a needle cover.
8. Drive arrangement according to any one of the preceding claims, wherein the plunger rod release member (117) is mechanically coupled to an interface member (115) wherein one of the plunger rod release member (117) and the interface member (115) comprises a helical interface feature (139) which is configured to convert an axial movement of the plunger rod release member (117) relative to the interface member (115) into an axial and rotational movement of the plunger rod release member (117) relative to the interface member (115).
9. Drive arrangement according to claim 8, wherein the interface member (115) comprises a guiding portion (157) for guiding the moveable trigger member (105) axially along the longitudinal axis.
10. Drive arrangement according to any one of claims 8 or 9, wherein the interface member (115) comprises a radial outward step or flange, wherein
 - a) the radial outward step or flange has an opening wherein the plunger rod release feature (141) extends into the interior of the interface member (115) through the opening and/or

b) the radial outward step or flange defines an end stop surface for the plunger rod release member (117) which stops movement of the plunger rod release member (117) when the plunger rod release feature (141) is moved towards the second position.

- 5 11. Drive arrangement according to any of claims 8 to 10, wherein the interface member (115) is a member separate from the housing (201) but axially and rotationally secured to the housing (201).
- 10 12. Drive arrangement according to any of the preceding claims, wherein, the interface (143) between the plunger rod release feature (141) and the retention feature (151) which is established in the first position comprises at least one surface which is inclined relative to the longitudinal axis, i.e. oblique to the longitudinal axis and non-perpendicular.
- 15 13. Drive arrangement according to any of the preceding claims, wherein the plunger rod release member (117) comprises a main body, and the plunger rod release feature (141) is movably connected to the main body.
- 20 14. Drug delivery device (100) comprising a drive arrangement according to any of the claims 1 to 13 and a reservoir (109), e.g. a syringe, and the drug delivery device (100) preferably comprises a medicament for injection.
- 25 15. Drug delivery device according to claim 14, the drug delivery device being a needle-based injection device with integrated non-replaceable container, where each container holds a single dose, whereby the entire deliverable volume is expelled when the device is operated for delivering the single dose.

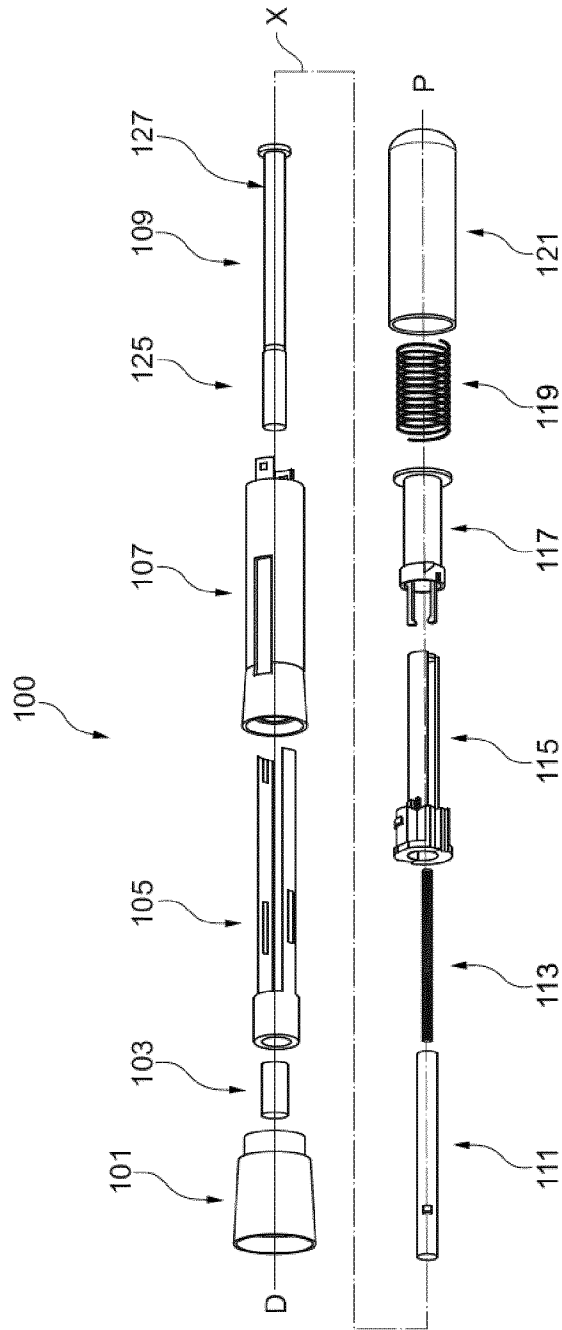

Fig. 1a

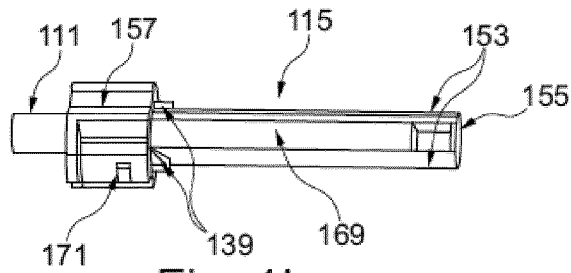

Fig. 1b

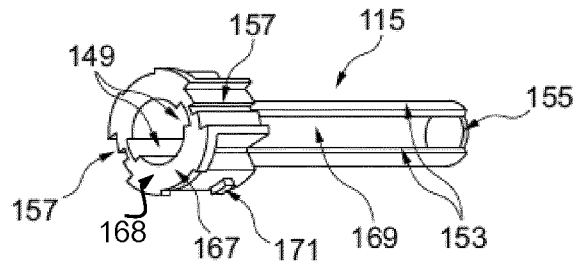

Fig. 1c

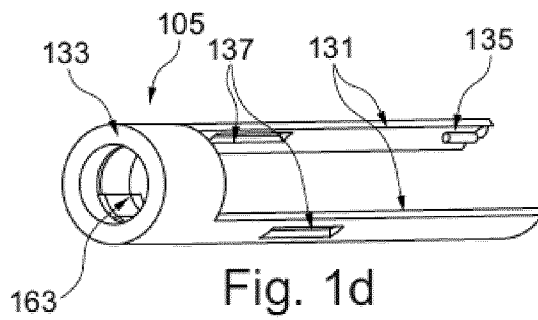

Fig. 1d

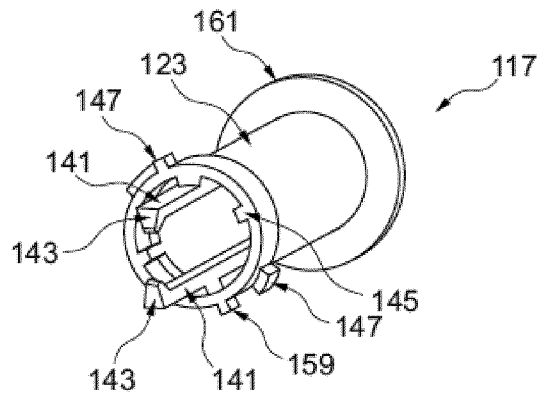
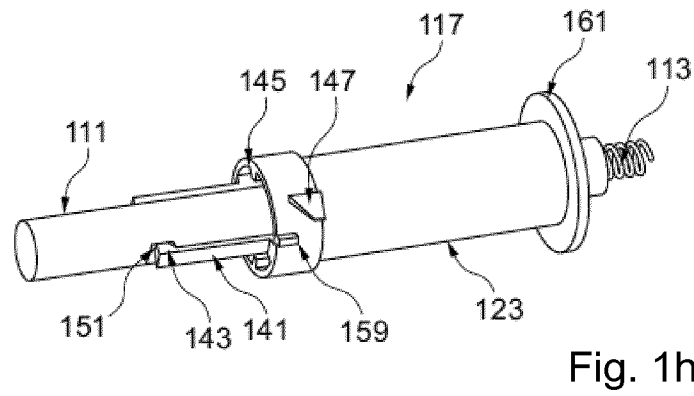
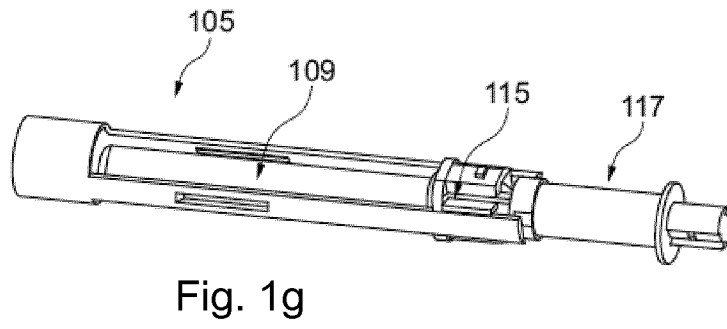
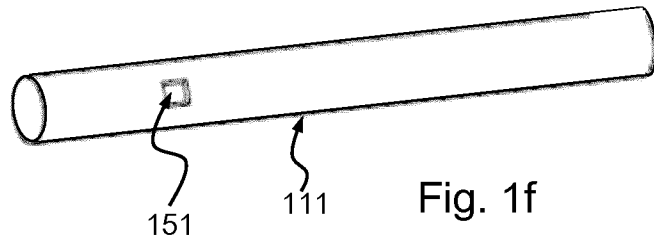

Fig. 1e



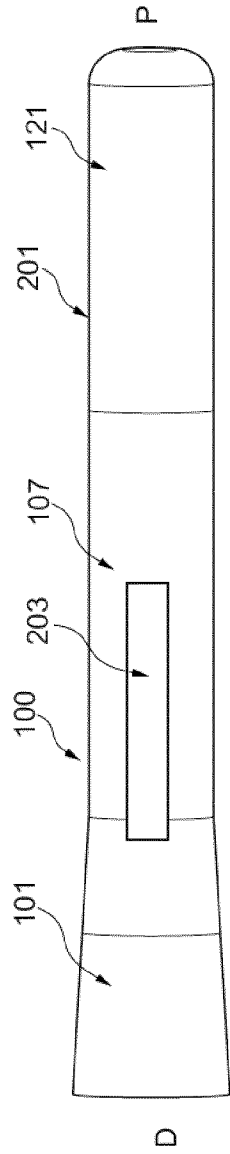

Fig. 2a

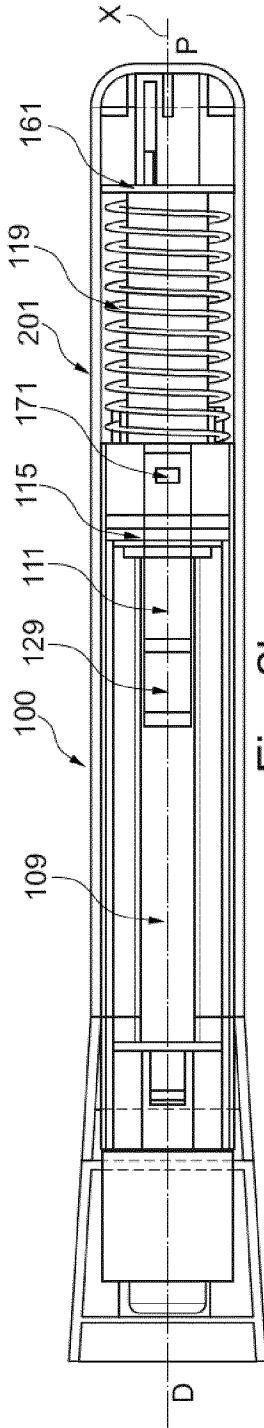

Fig. 2b

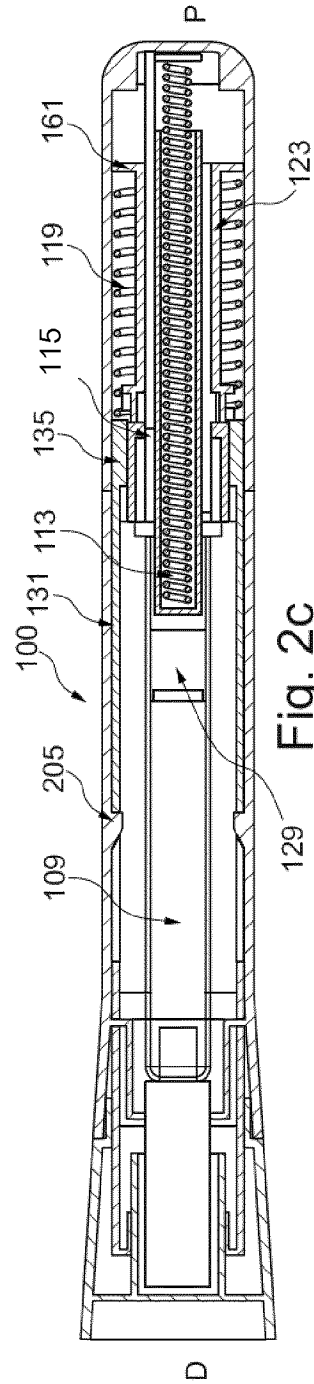

Fig. 2c

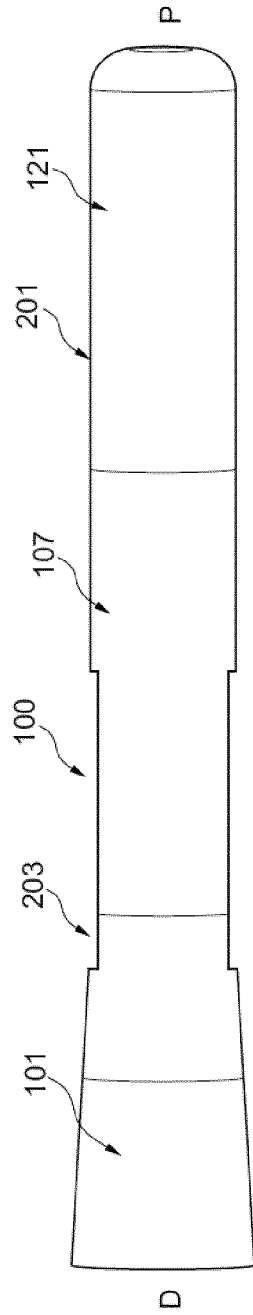

Fig. 2d

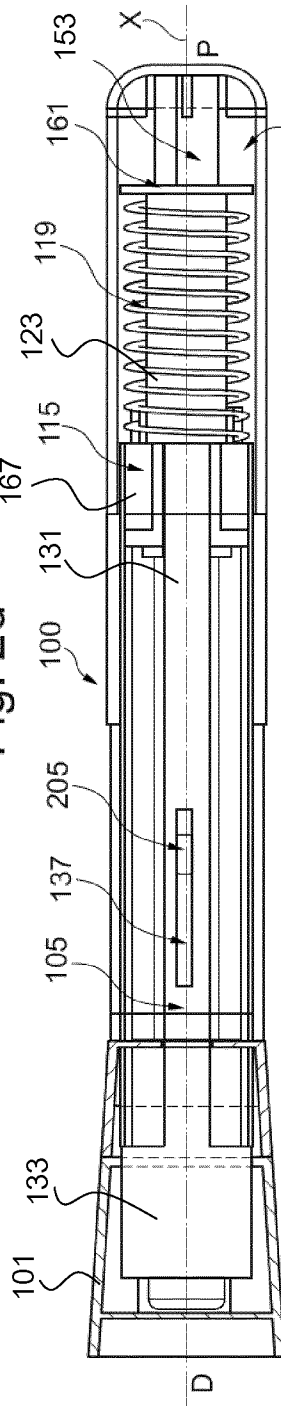

Fig. 2e

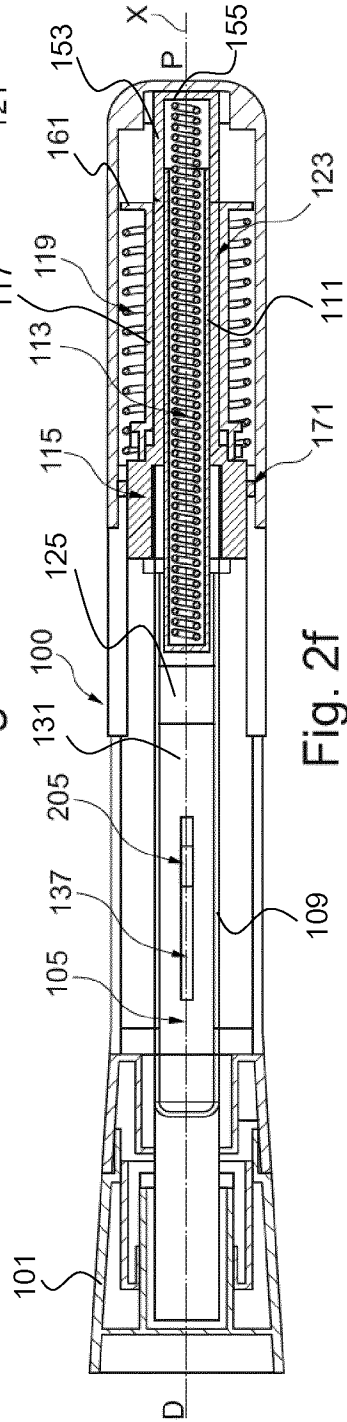

Fig. 2f

6/12

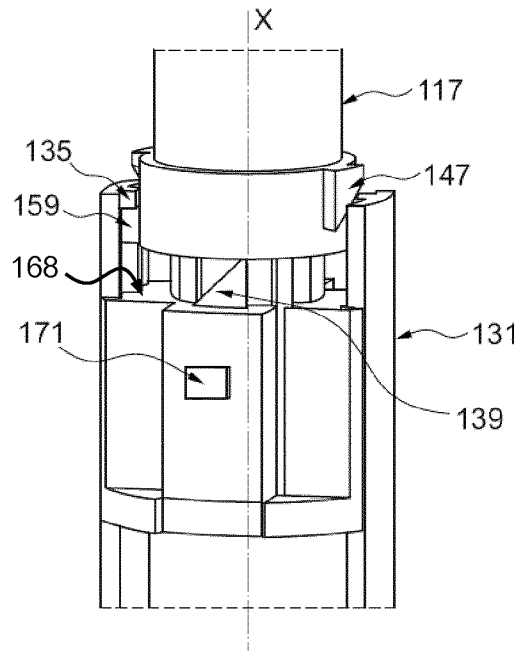

Fig. 3a

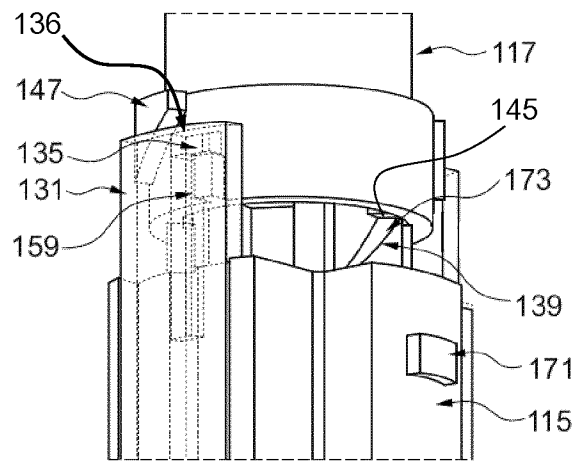

Fig. 3b

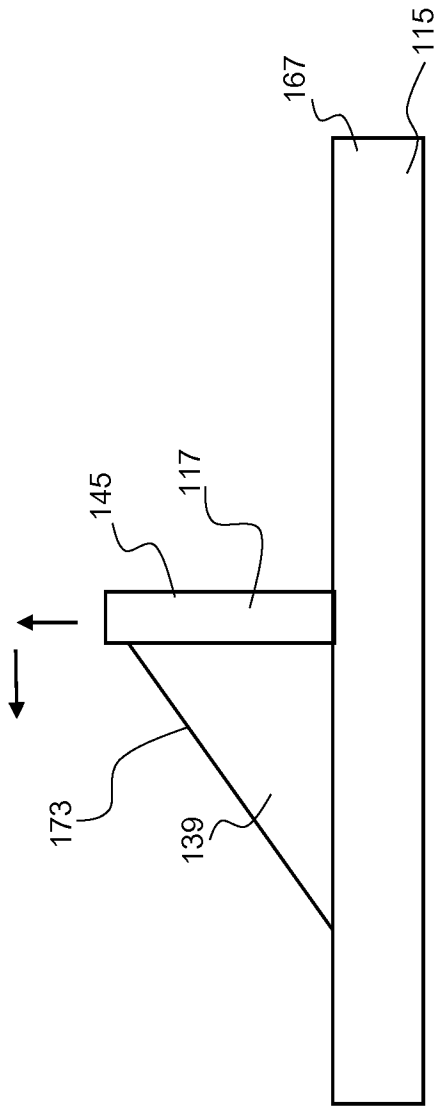

Fig. 3c

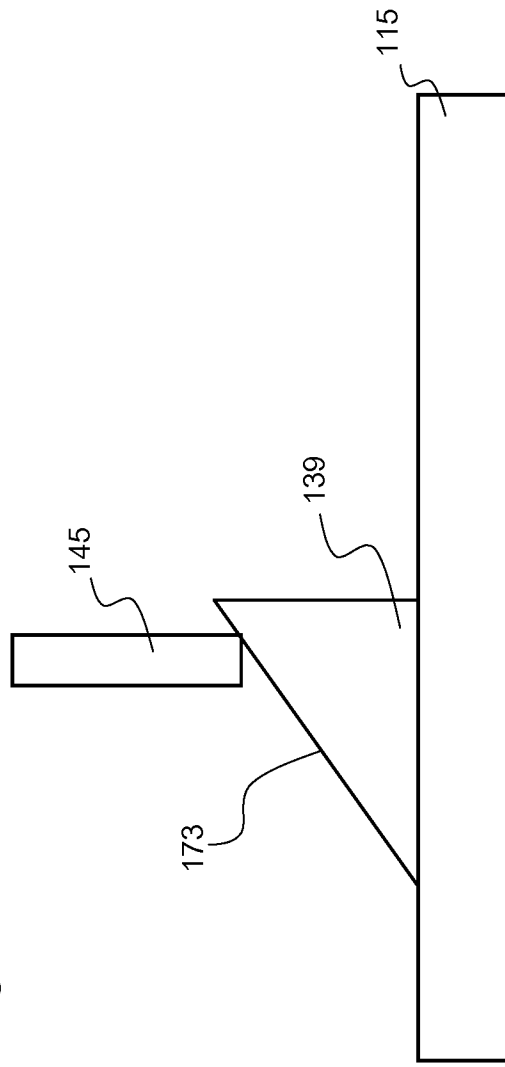

Fig. 3d

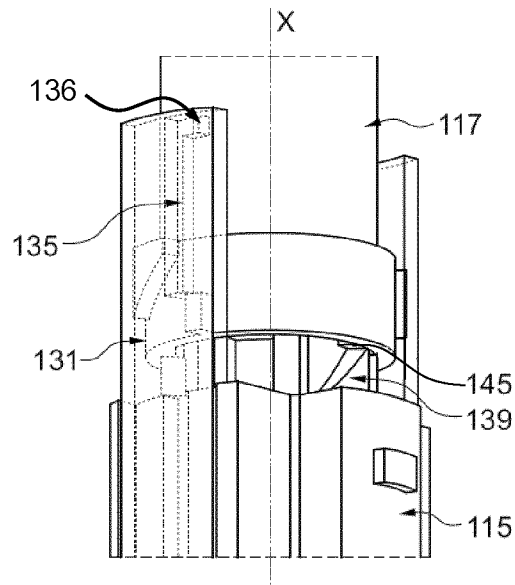

Fig. 4a

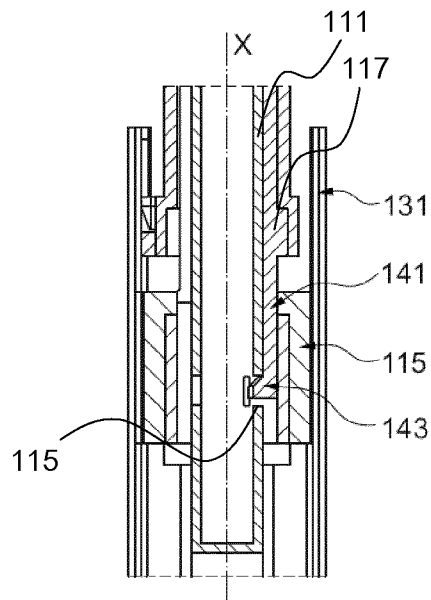

Fig. 4b

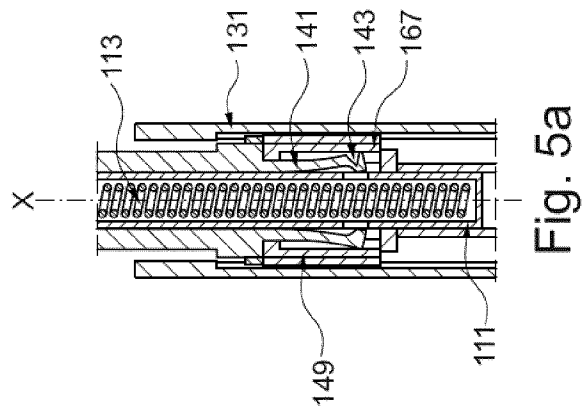
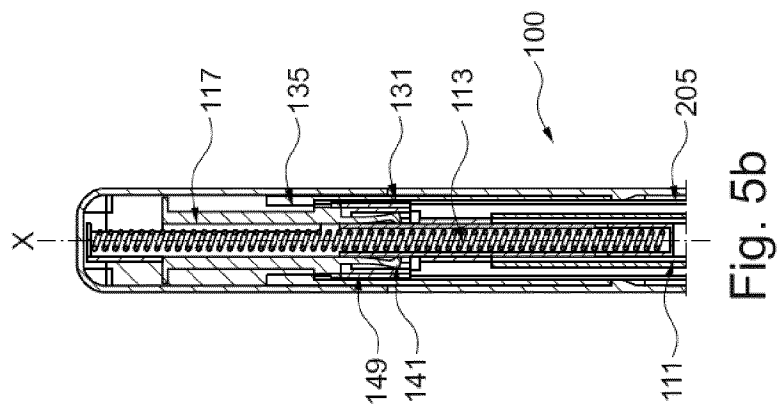
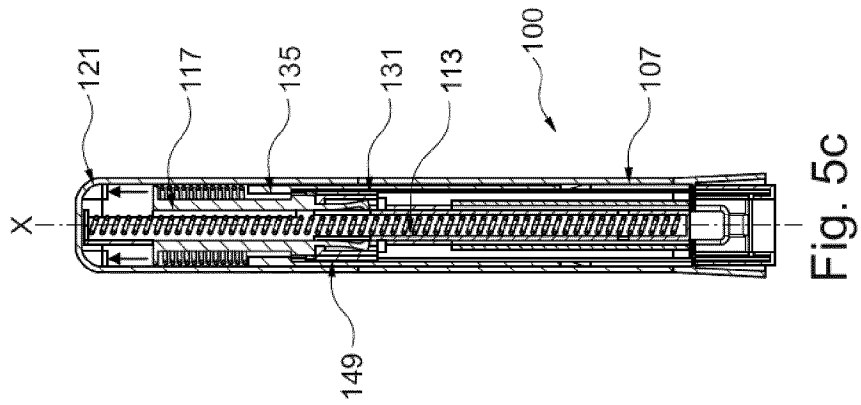

Fig. 5c

Fig. 5b

Fig. 5a

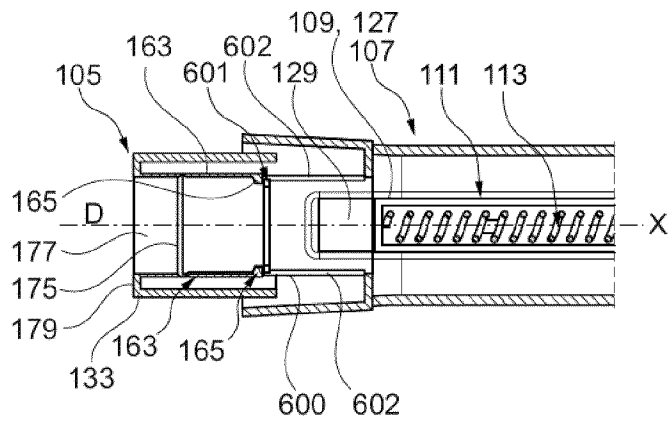

Fig. 6a

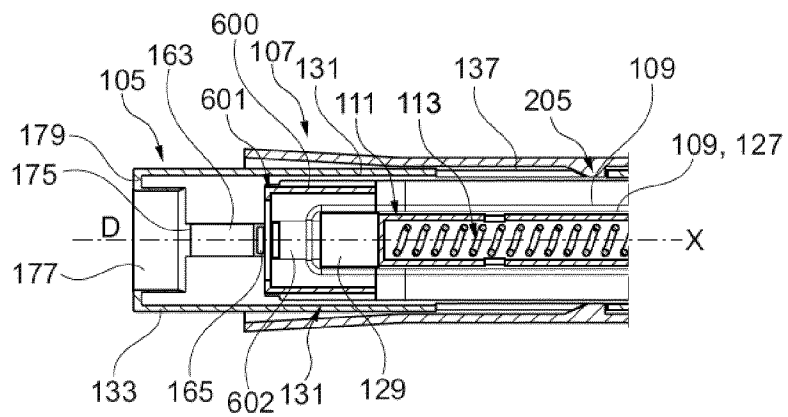

Fig. 6b

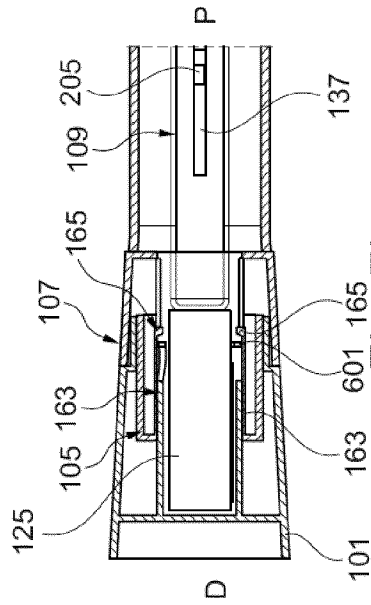

Fig. 7b

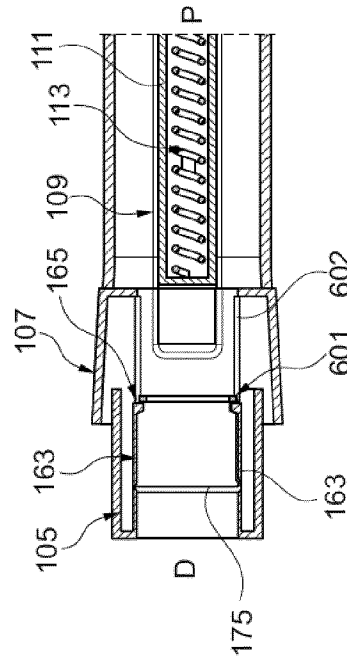

Fig. 7d

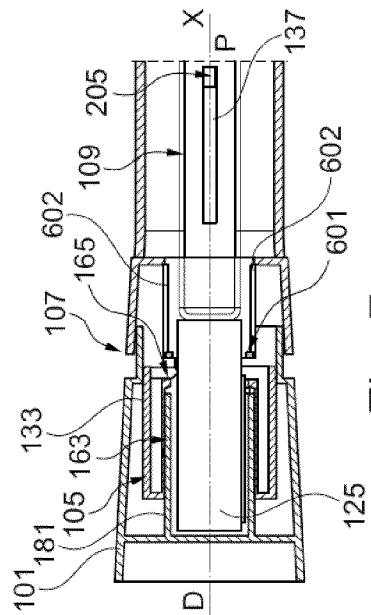

Fig. 7a

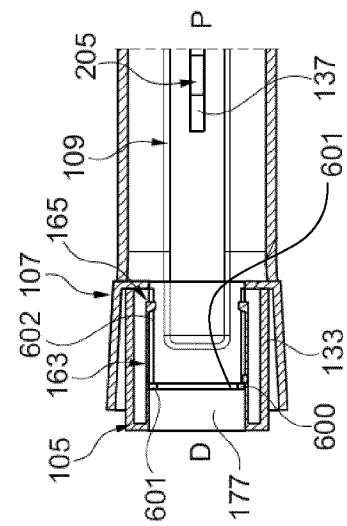

Fig. 7c

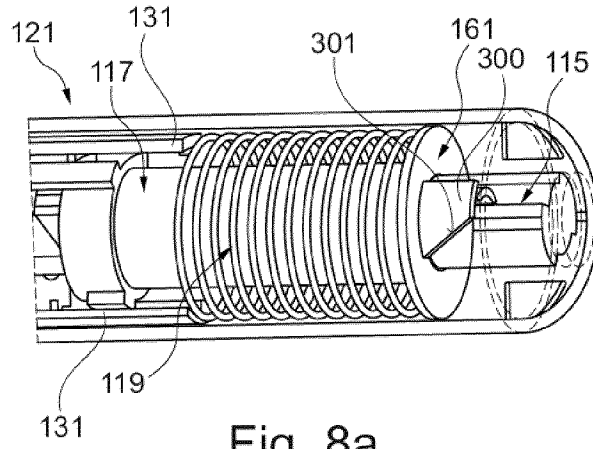

Fig. 8a

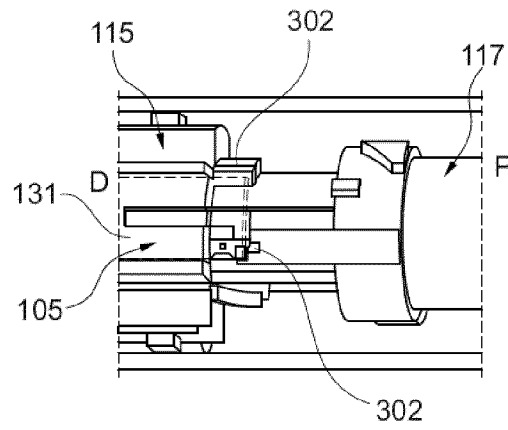

Fig. 8b

INTERNATIONAL SEARCH REPORT

International application No
PCT/EP2021/071606

A. CLASSIFICATION OF SUBJECT MATTER INV. A61M5/20 A61M5/315 A61M5/32 A61M5/31 ADD.		
According to International Patent Classification (IPC) or to both national classification and IPC		
B. FIELDS SEARCHED		
Minimum documentation searched (classification system followed by classification symbols) A61M		
Documentation searched other than minimum documentation to the extent that such documents are included in the fields searched		
Electronic data base consulted during the international search (name of data base and, where practicable, search terms used) EPO-Internal, WPI Data		
C. DOCUMENTS CONSIDERED TO BE RELEVANT		
Category*	Citation of document, with indication, where appropriate, of the relevant passages	Relevant to claim No.
X	EP 2 583 708 A1 (SHL GROUP AB [SE]) 24 April 2013 (2013-04-24) cited in the application figures 1b, 1c, 2a, 3, 4c, 5 paragraphs [0029], [0031], [0033], [0038], [0040], [0052], [0053] -----	1-15
X	EP 3 458 128 A1 (SHL MEDICAL AG [CH]) 27 March 2019 (2019-03-27) figures 5, 6, 7, 8, 9a paragraphs [0029], [0030], [0041], [0042], [0043], [0044], [0048], [0049], [0051] -----	1-15
A	US 2018/214637 A1 (KEMP THOMAS MARK [GB] ET AL) 2 August 2018 (2018-08-02) figures 1, 4, 8A-8E paragraphs [0070], [0073], [0075] - [0076], [0080] - [0086] -----	1-15
<input type="checkbox"/> Further documents are listed in the continuation of Box C. <input checked="" type="checkbox"/> See patent family annex.		
* Special categories of cited documents :		
"A" document defining the general state of the art which is not considered to be of particular relevance "E" earlier application or patent but published on or after the international filing date "L" document which may throw doubts on priority claim(s) or which is cited to establish the publication date of another citation or other special reason (as specified) "O" document referring to an oral disclosure, use, exhibition or other means "P" document published prior to the international filing date but later than the priority date claimed		"T" later document published after the international filing date or priority date and not in conflict with the application but cited to understand the principle or theory underlying the invention "X" document of particular relevance; the claimed invention cannot be considered novel or cannot be considered to involve an inventive step when the document is taken alone "Y" document of particular relevance; the claimed invention cannot be considered to involve an inventive step when the document is combined with one or more other such documents, such combination being obvious to a person skilled in the art "&" document member of the same patent family
Date of the actual completion of the international search 28 October 2021		Date of mailing of the international search report 22/11/2021
Name and mailing address of the ISA/ European Patent Office, P.B. 5818 Patentlaan 2 NL - 2280 HV Rijswijk Tel. (+31-70) 340-2040, Fax: (+31-70) 340-3016		Authorized officer Benes, Václav

INTERNATIONAL SEARCH REPORT

Information on patent family members

International application No

PCT/EP2021/071606

Patent document cited in search report	Publication date	Patent family member(s)	Publication date
EP 2583708	A1	24-04-2013	
		AU 2011233733 A1	18-10-2012
		CA 2790466 A1	06-10-2011
		CN 102917738 A	06-02-2013
		CN 103071208 A	01-05-2013
		CN 103120819 A	29-05-2013
		CN 103120820 A	29-05-2013
		CN 103143082 A	12-06-2013
		CN 105327432 A	17-02-2016
		DE 202011110155 U1	06-12-2012
		DK 2552517 T3	03-04-2017
		EP 2552517 A1	06-02-2013
		EP 2583708 A1	24-04-2013
		EP 2583709 A1	24-04-2013
		EP 2583710 A1	24-04-2013
		EP 2583711 A1	24-04-2013
		ES 2618905 T3	22-06-2017
		JP 5269268 B2	21-08-2013
		JP 5503776 B2	28-05-2014
		JP 5503777 B2	28-05-2014
		JP 5531144 B2	25-06-2014
		JP 2013146600 A	01-08-2013
		JP 2013146601 A	01-08-2013
		JP 2013146602 A	01-08-2013
		JP 2013173007 A	05-09-2013
		JP 2013526904 A	27-06-2013
		KR 20130012964 A	05-02-2013
		KR 20130012965 A	05-02-2013
		KR 20130012966 A	05-02-2013
		KR 20130012967 A	05-02-2013
		KR 20130021378 A	05-03-2013
		RU 2012146346 A	20-04-2013
		TW 201138884 A	16-11-2011
		TW 201422271 A	16-06-2014
		TW 201422272 A	16-06-2014
		TW 201422273 A	16-06-2014
		TW 201422274 A	16-06-2014
		US D794178 S	08-08-2017
		US D794777 S	15-08-2017
		US D816212 S	24-04-2018
		US D821573 S	26-06-2018
		US D834706 S	27-11-2018
		US D834707 S	27-11-2018
		US 2013035642 A1	07-02-2013
		US 2013041323 A1	14-02-2013
		US 2013041324 A1	14-02-2013
		US 2013041327 A1	14-02-2013
		US 2013041328 A1	14-02-2013
		US 2013041347 A1	14-02-2013
		US 2016067407 A1	10-03-2016
		US 2016089498 A1	31-03-2016
		US 2016279334 A1	29-09-2016
		US 2017209647 A1	27-07-2017
		US 2018318514 A1	08-11-2018
		US 2020238015 A1	30-07-2020
		US 2021085881 A1	25-03-2021
		US 2021085882 A1	25-03-2021
		US 2021085883 A1	25-03-2021
		US 2021268196 A1	02-09-2021

INTERNATIONAL SEARCH REPORT

Information on patent family members

International application No PCT/EP2021/071606

Patent document cited in search report	Publication date	Patent family member(s)	Publication date

		WO 2011123024 A1	06-10-2011

EP 3458128	A1	27-03-2019	
		CA 3024577 A1	23-11-2017
		CN 109152883 A	04-01-2019
		DK 3458128 T3	24-08-2020
		EP 3458128 A1	27-03-2019
		KR 20180135003 A	19-12-2018
		KR 20200063271 A	04-06-2020
		TW 201740988 A	01-12-2017
		US 2019192776 A1	27-06-2019
		WO 2017198383 A1	23-11-2017

US 2018214637	A1	02-08-2018	
		CN 107666924 A	06-02-2018
		EP 3302634 A1	11-04-2018
		HK 1247875 A1	05-10-2018
		JP 6774434 B2	21-10-2020
		JP 2019503207 A	07-02-2019
		TW 201707740 A	01-03-2017
		US 2018214637 A1	02-08-2018
		WO 2016193350 A1	08-12-2016
