



(51) International Patent Classification:

H01G 9/20 (2006.01) C03C 27/06 (2006.01)
C03C 3/11 (2006.01) C03B 23/203 (2006.01)
C03C 4/08 (2006.01)

(21) International Application Number:

PCT/US2011/049912

(22) International Filing Date:

31 August 2011 (31.08.2011)

(25) Filing Language:

English

(26) Publication Language:

English

(30) Priority Data:

61/379,874 3 September 2010 (03.09.2010) US
10306325.1 30 November 2010 (30.11.2010) EP

(71) Applicant (for all designated States except US): **CORNING INCORPORATED** [US/US]; 1 Riverfront Plaza, Corning, New York 14831 (US).

(72) Inventors; and

(75) Inventors/Applicants (for US only): **LOGUNOV, Stephan L** [US/US]; 2780 Pinewood Circle, Corning, New York 14830 (US). **PRASSAS, Michel** [FR/FR]; 16 Rue Saint Eloi, F-77870 Vulaines sur Seine (FR).

(74) Agent: **WATSON, Bruce P**; Corning Incorporated, Intellectual Property Department, SP-Ti-03-01, Corning, New York 14831 (US).

(81) Designated States (unless otherwise indicated, for every

kind of national protection available): AE, AG, AL, AM, AO, AT, AU, AZ, BA, BB, BG, BH, BR, BW, BY, BZ, CA, CH, CL, CN, CO, CR, CU, CZ, DE, DK, DM, DO, DZ, EC, EE, EG, ES, FI, GB, GD, GE, GH, GM, GT, HN, HR, HU, ID, IL, IN, IS, JP, KE, KG, KM, KN, KP, KR, KZ, LA, LC, LK, LR, LS, LT, LU, LY, MA, MD, ME, MG, MK, MN, MW, MX, MY, MZ, NA, NG, NI, NO, NZ, OM, PE, PG, PH, PL, PT, QA, RO, RS, RU, RW, SC, SD, SE, SG, SK, SL, SM, ST, SV, SY, TH, TJ, TM, TN, TR, TT, TZ, UA, UG, US, UZ, VC, VN, ZA, ZM, ZW.

(84) Designated States (unless otherwise indicated, for every

kind of regional protection available): ARIPO (BW, GH, GM, KE, LR, LS, MW, MZ, NA, SD, SL, SZ, TZ, UG, ZM, ZW), Eurasian (AM, AZ, BY, KG, KZ, MD, RU, TJ, TM), European (AL, AT, BE, BG, CH, CY, CZ, DE, DK, EE, ES, FI, FR, GB, GR, HR, HU, IE, IS, IT, LT, LU, LV, MC, MK, MT, NL, NO, PL, PT, RO, RS, SE, SI, SK, SM, TR), OAPI (BF, BJ, CF, CG, CI, CM, GA, GN, GQ, GW, ML, MR, NE, SN, TD, TG).

Published:

— with international search report (Art. 21(3))

(54) Title: PROCESS FOR SEALING A GLASS PACKAGE AND RESULTING GLASS PACKAGE

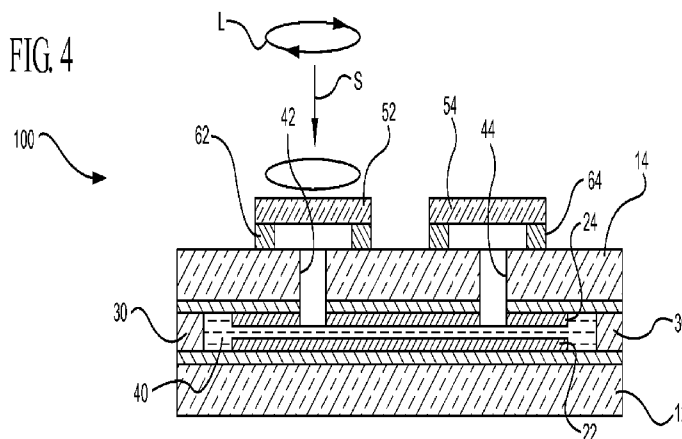

(57) Abstract: A method is provided for sealing one or more fill holes (42, 44) in a glass plate (14) of an organic dye solar cell and other glass packages by covering the hole(s) (42, 44) with a laser absorbing glass patch (52, 54). The outer perimeter of the glass patch (52, 54) is melted with a laser such that the outer perimeter of the glass patch (52, 54) is hermetically sealed to the glass plate (14). Another method is provided in which the fill holes (42, 44) are covered with a glass patch (52, 54) having a loop of absorbing frit around the outer periphery thereof. The loop of frit is melted with a laser such that the outer perimeter of the glass patch (52, 54) is hermetically sealed to the glass plate (14). In both process, the laser beam is either (1) formed into a loop shape beam around the perimeter of the glass patch (52, 54) or (2) quickly travels around the perimeter of the glass patch (52, 54) in such a manner that the loop of frit or the entire perimeter of the absorbing glass patch (52, 54) is uniformly heated to substantially the same temperature to minimize thermal stresses created during heating and sealing.



PROCESS FOR SEALING A GLASS PACKAGE AND RESULTING GLASS PACKAGE

CROSS-REFERENCE TO RELATED APPLICATIONS

[0001] This application claims the benefit of priority under 35 U.S.C. § 119 of U.S. Provisional Application Serial No. 61/379,874 filed on September 3, 2010 and European Patent Application Serial No. 10306325.1 filed on November 30, 2010, both applications being incorporated herein by reference.

BACKGROUND

[0002] This disclosure relates to a process for sealing glass packages containing liquid, and more particularly, a heat sensitive liquid, such as an organic electrolyte solution in sensitized dye solar cells, and more particularly, to a process for sealing fill holes in a heat sensitive liquid containing glass package by laser sealing a glass patch over the fill holes; and to a sealed liquid filled glass package, such as a sensitized dye solar cell.

[0003] Due to the volatile supply, high costs and environmental concerns with conventional energy sources such as oil and coal, the research, development and use of alternative energy sources has increased in recent years. One alternative energy source that has been garnering increased research and use in recent years is photovoltaic devices or solar cells that convert the sun's photons into electricity. Currently, the most widely used solar cells are silicon based photovoltaic devices. However, the high cost of silicon combined with the relatively low efficiency and electrical output of these devices make them economically unviable for many applications.

[0004] A relatively newer, less expensive approach to photovoltaics is dye solar cell technology discovered by Michael Grätzel that uses dye sensitized mesoscopic oxide particles between two electrode bearing glass plates to convert sunlight into electricity. One type of dye solar cells is an organic dye solar cell, which contains dye and a heat sensitive organic electrolyte solution. As illustrated in Figures 1 and 2, current organic dye solar cell module designs 10 typically include two glass plates 12 and 14, each with a thin conductive coating 22, 24 separated by approximately 20 μm to 30 μm . One of the glass plates 12 is coated on its inside surface with a thin TiO_2 layer electrode layer 22 that serves as an anode electrode. The other glass plate 14 is coated with a thin Pt layer electrode layer 24 on its

inner surface that serves as a cathode electrode. As is well understood in the art, a solar panel cell module typically consists of many solar dye cells between the two glass plates. Collection electrodes (such as Ag silver electrodes, not shown) extend to each cell to collect current from each cell. The electrode layers can withstand temperatures of up to 450° C, so the two glass plates may be sealed together with a loop of low melting temperature glass frit 30 or other inorganic low melting temperature sealing material. The loop of frit 30 may be pattern/deposited over the electrode layer 22 on the first glass plate 12 (or the second glass plate 14). The second glass plate 14 is then placed against the first glass plate with the electrode layer 24 on the second glass plate in contact with the loop of frit 30 on the first glass plate 12. Individual cell modules may contain several cells connected in series, in which case, a common frit loop may surround, seal and isolate all of the cells in the module as a group.

[0005] The entire assembly is then heated in an oven to a temperature above the melting temperature of the frit material, but below 450° C, in order to melt the frit material. The assembly is then cooled, such that the frit hardens and joins the two glass plates 12 and 14 together and forms a hermetic seal around the periphery of the solar cell or the periphery of the two glass plates 12 and 14. Since collector electrodes (such as Ag electrodes, not shown) may be sensitive to corrosion by the electrolyte material contained in an organic dye solar cell, the sealing perimeter for each cell isolates the active cell areas filled with electrolyte solution from the Ag electrodes. The loop of frit 30 is deposited with a height such that it forms approximately a 20 μm to 30 μm gap between the two glass plates after melting and hardening of the frit, thereby creating a cell cavity 40 between the two glass plates 12 and 14. The two glass plates 12 and 14 may alternatively be sealed together at room temperature with a polymeric sealing material in place of the inorganic sealing material. However, a polymeric sealing material does not form a hermetic seal and the useful lifetime of the cell is therefore detrimentally effected compared to a cell that is hermetically sealed with an inorganic material.

[0006] Each dye solar cell typically has at least one, or typically two or more fill holes 42 and 44 through one of the glass plates. After sealing the two glass plates together with the frit material, the fill holes are used to stain the inner surfaces of the two glass plates with a dye solution and the dye solution is removed from the cell cavity. The fill holes are then used to

fill the cell cavity 44 with an electrolyte solution by inserting the electrolyte solution through one of the fill holes into the cell cavity until the cavity is completely filled with solution in a second step, while air is allowed to escape through the second fill hole to prevent the formation of air bubbles in the cavity. The fill holes are then typically closed and sealed with a polymeric sealing material 46, which does not form a hermetic seal.

[0007] Polymeric sealing materials are typically employed to seal the fill holes due to the heat sensitive nature of the organic electrolyte solution contained in the cell. A sealing process that would heat any portion of the organic electrolyte solution contained in the cell to a temperature above 120° C or above about 150° C cannot be employed to seal the fill holes without detrimentally affecting or degrading the organic electrolyte solution. Glass frit and other inorganic sealing materials typically have a melting point of a least 450° C or higher. It is therefore difficult to employ a hermetic inorganic sealing material, such as glass frit, for sealing the fill holes without damaging the organic dye material contained in the cell. As a result, polymeric sealing materials are typically used to seal the fill holes, so that the fill holes can be sealed at approximately room temperatures below 150° C without damaging the organic electrolyte solution contained in the cell during the sealing process. However, such a polymeric seal is not hermetic, which limits the useful lifetime of the solar cell. There is therefore a need in the art for a low cost process for hermetically sealing the fill holes in an organic dye solar cell.

[0008] The owner of this application, Corning Incorporated, has developed a process for sealing the perimeter of heat sensitive devices, such as organic light emitting diode devices, by heating the loop of frit between two glass plates encapsulating the devices with a laser beam. For example, see Corning owned U.S. Patent Numbers 6,998,776; 7,407,423 and 7,344,901. However, these sealing processes were developed for relatively low coefficient of thermal expansion (CTE) materials, such as Corning Incorporated's Eagle™ display glass, which is a relatively expensive high quality glass developed for use in the production of liquid crystal displays. Organic dye solar cells, on the other hand, are typically manufactured with relatively low cost, low quality and relatively high CTE, as compared with display glass, soda lime glass due to the cost targets required to make solar cells economically feasible. Soda lime glass typically has a CTE in a range from about 80×10^{-7} to about 90×10^{-7} per degree C, while Corning's laser sealing technology was primarily developed for sealing the

perimeter of lower CTE glasses, for example, glasses with a CTE $<50 \times 10^{-7}$ per degree C. The difference between the CTE of soda lime glass and the CTE of display glass makes a big difference in sealing performance due to the increased residual and transient stresses created in the frit and soda lime glass compared to the stresses created in the frit and glass when sealing relatively low CTE display quality glass. These processes were also developed for sealing a loop of glass frit having a perimeter > 30 mm long, not for sealing a small 2 mm diameter hole. Furthermore, these sealing processes were not developed for sealing a cell that is completely filled with temperature sensitive materials, such as an organic electrolyte solution. In these existing processes, the temperature sensitive materials or devices, such as OLED devices, must be offset from the perimeter frit seal/wall by a minimum distance in order to prevent overheating of the organic sensitive material or devices during laser sealing. It is not possible to space a liquid solution filling the cell from the fill holes without the costly addition of additional space consuming and costly structure for just this purpose.

[0009] Corning Incorporated has also developed a process for laser frit sealing the perimeter of relatively higher CTE glasses such as soda lime glass, for example see published U.S. Patent Application No. 2010/0129666 and published international application WO 2010/014161, but there are restrictions on the glass thickness that may be effectively sealed using these processes. Using this process for laser frit sealing relatively higher CTE glass plates having a thickness equal to or greater than about 2.2 mm, which is approximately the lower thickness limit for the float process used to manufacture low cost soda lime glass plates as are typically used for dye solar cells, results in unsatisfactorily low yields, making this process economically unviable and ineffective for sealing organic dye solar cells manufactured with such high CTE glass plates. Furthermore, as described above, organic dye solar cells typically include conductive coatings on the soda lime glass plates, which makes sealing even more difficult and results in even lower yields. In these processes, the solution inside the cell contacting the frit is typically heated during the sealing process to relatively high temperatures, e.g. the melting temperature of the frit, that are unacceptable when sealing organic dye solar cells.

[0010] Corning Incorporated has also developed a process for laser frit sealing the perimeter of devices containing liquid, for example see aforementioned published international application WO 2010/014161. However, as previously described in relation to the laser

sealing process disclosed in published U.S. Patent Application No. 2010/0129666 and published international application WO 2010/014161, these processes were developed for sealing display quality glass. Laser frit sealing of devices made with economical soda lime glass plates with these processes would likely result in unsatisfactorily low yields. Also, these existing processes were not developed for sealing glass packages containing heat sensitive solutions or devices.

[0011] There is a need in the art for a process for economically sealing the fill holes in a sensitized organic dye solar cell in an economical soda lime glass package with a hermetic inorganic sealing material. Furthermore, there is a need for a less expensive manufacturing process to make many different types of glass packages that contain a liquid or devices that may be heat sensitive, such as, for example, electro-wetting displays and OLED displays. This need and other needs are satisfied by the disclosed method for sealing a glass package and the resulting glass package.

SUMMARY

[0012] According to at least one embodiment of this disclosure, a method is provided for encapsulating/sealing one or more fill holes in a glass package containing heat sensitive liquid, such as an organic dye solar cell, by covering the hole(s) with a thin (for example, < about 0.7 mm thick) laser absorbing cover glass or glass patch having a CTE of less than about 50×10^{-7} per degree C. The perimeter of the glass patch is then melted, thereby fusing glass patch to the glass plate and hermetically sealing to the hole in the glass plate. The perimeter of the glass patch is heated, for example with a laser, in such a manner that the entire perimeter of glass patch is uniformly heated to a substantially uniform temperature without heating the electrolyte solution in the package to a temperature over 120° C or over 150° C.

[0013] According to a further embodiment hereof, a method is provided for encapsulating one or more fill holes in a glass plate of an organic dye solar cell by covering the hole(s) with a thin cover glass. The perimeter of the cover glass is hermetically sealed to the glass plate using a laser to melt a laser absorbing loop of frit in such a manner that the loop of frit is uniformly heated to the same temperature without heating the electrolyte solution in the package to a temperature over 120° C or over 150° C.

[0014] Additional features and advantages will be set forth in the detailed description which follows and will be readily apparent to those skilled in the art from the following description or recognized by practicing the embodiments as described in the following the detailed description, claims, and appended drawings.

[0015] It is to be understood that both the foregoing general description and the following detailed description are merely exemplary, and are intended to provide an overview or framework to understanding the nature and character of the claims. The accompanying drawings are included to provide a further understanding, and are incorporated in and constitute a part of this specification. The drawings illustrate one or more embodiment(s), and together with the description serve to explain principles and operation of the various embodiments.

BRIEF DESCRIPTION OF THE DRAWINGS

[0016] Figure 1 is a diagrammatic plan view of a Prior Art organic dye solar cell;

[0017] Figure 2 is a cross-sectional side view of the Prior Art organic dye solar cell of Fig. 1 taken along line 2 – 2 in Fig. 1;

[0018] Figure 3 is a diagrammatic plan view of a sealed organic dye solar cell according an embodiment hereof;

[0019] Figure 4 is a cross-sectional side view of the organic dye solar cell of Fig. 1 taken along line 4 – 4 in Fig. 1;

[0020] Figure 5 is a diagrammatic illustration of a system for sealing the fill holes of a dye solar cell according to an embodiment hereof;

[0021] Figure 6 is a plot illustrated the laser power profile according to an embodiment hereof; and

[0022] Figure 7 is a diagrammatic illustration of a system for sealing the fill holes of a dye solar cell according to another embodiment hereof.

DETAILED DESCRIPTION

[0023] Reference will now be made in detail to the exemplary embodiment(s) hereof as illustrated in the accompanying drawings. Where possible, the same reference numerals are used throughout the drawings to refer to the same or like parts.

[0024] Referring now to Figs. 3 and 4, there is disclosed an organic dye solar cell 100 that has been sealed in accordance with an embodiment hereof. The organic dye solar cell 100 includes a first glass plate 12 and a second glass plate 14. Anode electrodes may be formed on the inner surface on the first glass plate by a thin TiO₂ layer 22 on top of a thin conductive coating (TCO). The TiO₂ electrode may have a thickness of approximately about 2 μm to about 8 μm, which is less than the width of the gap formed between two glass plates. A thin conductive Pt salt layer 24 may be formed on the inner surface of the second glass plate 14 to form a cathode electrode. An outer peripheral portion of the inner surface of the first glass plate may be fused and hermetically sealed to an outer peripheral portion of the inner surface of the second glass plate by a loop (or looped wall or frame) of glass frit or other inorganic sealing material 30. The loop of frit 30 also serves to space the inner surface of the first glass plate from the inner surface of the second glass plate by a distance of about 20 μm to about 30 μm, thereby forming a cell cavity 40 between the two glass plates 12 and 14 for containing the organic electrolyte solution. The cell cavity is defined by an interior side of the frit, the inner surface of the first glass plate 12 and the inner surface of the second glass plate 14. The details of the material and structure of the electrode layers; the composition, deposition and melting of frit; and the composition of the organic electrolyte solution are well known in the art and are not described in detail herein. The present disclosure is primarily directed at the hermetic sealing of the glass package and the hermetic sealing of fill holes in one of the glass plates.

[0025] The second glass plate 14 includes at least one, or typically two or more fill holes 42 and 44 having a diameter of up to 2 mm passing therethrough for filling the cell cavity 40 with organic electrolyte solution as described in more detail below. The fill hole(s) may alternatively be located in the first glass plate 12, but may then block the light from irradiating the cell. One or more glass patches 52 and 54 cover the two or more fill holes 42 and 44. Two fill holes 42 and 44 and two corresponding glass patches 52 and 54 are illustrated in Figs. 3 and 4. However, if the fill holes may be placed close enough together,

then a single glass patch may cover and seal both of the fill holes. An outer peripheral portion of the inner surface of the glass patches 52 and 54 are fused and hermetically sealed to the outer surface of the second glass plate by loops (or looped walls or frames) of glass frit sealing material 62 and 64. The fill holes 42 and 44 are thus hermetically sealed by the glass patches 52 and 54 and frit loops 62 and 64, forming a completely hermetically sealed solar dye cell or glass package 100.

[0026] Only one solar cell is illustrated in the Figures 2-4. However, typically there will be a plurality of solar cells between the first and second glass plates in a single cell module. Typically, the cavities of all cells in a module are connected together, so that only a single pair of fill holes is required to fill all the cells in a module. However, if the cells in a module are not interconnected, then each cell may have its own pair of fill holes. Current gathering electrodes are formed on the glass plates between the cells to collect the current from the cathode and anode of each cell.

[0027] By way of example, a method for manufacturing the sealed glass package 100 in accordance with an embodiment hereof will now be described. First, the first glass plate 12 and the second glass plate 14 with at least one, or typically two or more fill holes 42 and 44 therethrough are provided. The first and second glass plates are transparent glass plates, such as soda lime glass plates or glass plates like the ones manufactured and sold by Corning Incorporated under the brand names of Code 1737 glass or Eagle 2000™ glass. Alternatively, the first and second glass plates can be transparent glass plates like the ones manufactured and sold by companies like Asahi Glass Co. (e.g., OA10 glass and OA21 glass), Nippon Electric Glass Co., NH Techno and Samsung Corning Precision Glass Co. (for example). If desired, one of the glass plates may be non-transparent. For dye solar cell and other cost sensitive applications that do not require display quality glass, the first and second glass plates may be relatively cheap, relatively high CTE glasses, such as soda lime glass, having a coefficient of thermal expansion (CTE) in the range from about 80×10^{-7} to about 90×10^{-7} per degree C. Typically, such economical glasses have a thickness of about 2.2 mm or more. Relatively more expensive relatively low CTE display quality glasses with a CTE of a less than about 50×10^{-7} per degree C may be required for display applications. The TC (transparent conductive) electrode layers, and any other desired electrical components (e.g., OLEDs 106) and associated electrodes, are deposited onto the first glass plate and the second

glass plate, as is well understood in the art. This particular step can be omitted if a glass package that contains only a liquid is being made in accordance with the sealing process of the present invention.

[0028] Frit 30 is then deposited around the outer periphery of a first, inner surface of the first glass plate 12 over the electrode layer 22, such that the frit forms a closed-loop on the inner surface of the first glass plate. For instance, the frit can be placed approximately about 1 mm away from the free edges of the first glass plate 102. The frit may then be pre-sintered to the first glass plate in an oven, so that the frit becomes attached to the first glass plate and is hardened to inhibit damaging of the loop of frit. If desired, the pre-sintered frit 110 can be ground to reduce its thickness variation.

[0029] The inner surfaces of the first 12 and second 14 glass plates with the electrodes thereon are placed together, with the loop of frit 30 on the first glass plate contacting a first, inner surface of the second glass plate. The plates can be sealed in a furnace at a temperature that is higher than the melting point of the glass frit but lower than the softening temperature of the glass plates, such as up to about 400° C, to melt the frit and hermetically seal the glass plates together. In one embodiment, the frit 30 may be a low temperature glass frit. In the case of relatively high CTE glass plates, such as soda lime glass plates having a CTE in a range from about 80×10^{-7} to about 90×10^{-7} per degree C, it may be desirable to use a frit with a CTE that substantially matches that the CTE of the glass plates.

[0030] Next the dye solution is deposited into the cell cavity 40 through the holes to stain TiO₂ electrode. Then dye solution is removed and package is dried.

[0031] Next, the organic electrolyte solution is deposited into the cell cavity 40 through a first of the fill holes 42 until the cavity is completely filled with solution. As the cell cavity fills with organic electrolyte solution, air escapes out a second of the fill holes 44, such that no air bubbles remain in the cavity.

[0032] A sealing cover glass or glass patch 52 having a loop (or looped wall or frame) of glass frit sealing material 62 deposited on and pre-sintered (as previously described herein relative to the loop of frit on the first glass plate) to a first or inner surface of the glass patch is provided. The glass patch 52 is placed on the outer surface of the second glass plate 14 with the loop of frit on the inner surface of the glass patch placed against the outer surface of the second glass plate surrounding a first or one of the fill holes 42. A sealing device (e.g., a

laser or infrared lamp or other high energy beam) is then used to melt the glass frit 62 (arrow S in Figs. 3 and 4 indicates a laser beam), thereby attaching the glass patch 52 to the second glass plate 14 and hermetically sealing the first fill hole 42 with the first glass patch and loop of frit without heating the electrolyte solution in the to a temperature over about 120° C or over about 150° C. A second glass patch 54 is placed over the second or other of the fill holes 44, and the sealing device is used to melt the glass frit 64, thereby attaching the second glass patch to the second glass plate and hermetically sealing the second fill hole with the second glass patch and loop of frit. As previously described, a single glass patch with a single loop (or two loops) of frit that surrounds both of the fill holes in the glass plate may alternatively be employed to seal both of the fill holes. A sealed dye solar cell or glass package 100 that is hermetically and durably sealed entirely with inorganic glass frit sealing material 30, 62, and 64 is thus provided.

[0033] The sealing wavelength is different from any absorption peaks of the solar cell components so that only the frit material is heated during sealing. For example, the solar cell may be designed with a high absorption of Sun light. The sealing wavelength may be outside of the absorbing range of the cell components, such as a wavelength that is longer than about 750 nm or substantially equal to or longer than about 800 nm, or substantially equal to or longer than about 810 nm. The absorbing frit or the absorbing glass of the sealing line may then be designed to absorb light in these frequencies, e.g. longer than about 750 nm, or substantially equal to or longer than about 800 nm, or substantially equal to or longer than about 810 nm.

[0034] The seal contains the organic electrolyte solution or other liquid in the cell cavity between the first glass plate and the second glass plate. In addition, the seal protects any electrical components contained within the cavity by preventing, for example, oxygen and moisture located within the ambient environment from entering into the sealed glass package.

[0035] According to an embodiment hereof, the sealing device can be used to emit a concentrated beam of light (such as a laser beam, or infrared beam) that heats the frit loop 62, 64 in a manner such that the temperature of the frit loop is uniformly increased to a substantially constant temperature around its entire periphery. As illustrated by arrow L in Figs. 4 and 5, the laser beam 220 is moved along the loop of frit 62, 64 (e.g. along a sealing line). In order to minimize temperature variations and resulting stresses in the frit, glass

patch and second glass plate, for a frit line width of about 0.7 mm and a laser beam spot size of about 1 mm in diameter, for example, the laser beam is repeatedly moved quickly around the loop of frit at a relatively high speed in range from about 1 m/s to about 2 m/s (e.g. fast scanned). In this manner, the temperature of the entire frit loop is raised bit by bit with each pass/circuit of the laser beam, such the temperature of the frit is always substantially the same or equal around the entire loop of frit. The temperature of the frit is raised (for example to about 400° C) until the frit melts, connecting the glass patch to the second glass plate and forming the hermetic seal, without heating the electrolyte solution in the cell cavity to a temperature over about 120° C or over about 150° C, or only heating it to a temperature in a range from about 100°C to about 120°C. This constant temperature sealing technique is described in more detail after a discussion is provided about some exemplary glass patches, glass packages and glass frits that can be used to make the dye solar cell or other glass package.

[0036] An exemplary process for fabricating a glass patch will now be described. First, a glass patch is provided. The glass patch may be a relatively thin patch of display quality glass, such as Corning Eagle glass having a thickness in range from about 0.4 mm to about 0.7 mm. Glass frit or other inorganic sealing material is deposited around the outer periphery of a first, inner surface of the glass patch, such that the frit forms a closed-loop on the outer peripheral portion of the first inner surface of the glass patch. For instance, the frit can be placed approximately about 1 mm or less away from the free edges of the first glass patch.

[0037] In an alternative embodiment hereof, a glass patch formed of a light absorbing glass is provided with a thickness in range from about 0.4 mm to about 0.7 mm. The absorbing glass patch may be formed of a dark glass, such as glass having by weight percentage a composition including 54.92% SiO₂, 5.93% Al₂O₃, 23.27% B₂O₃, 0.43% Li₂O, 1.92% K₂O, 3.25% Fe₂O₃, 6.13% CuO, 2.64% V₂O₅, 1.48% Cl, such that the entire glass patch is formed of a dark light absorbing glass. Such a dark light absorbing glass may have a relatively low CTE of less than 40x10⁻⁷ per degree C, or from about 35x10⁻⁷ per degree C to about 40x10⁻⁷ per degree C. Alternatively, the absorbing glass patch may be display quality glass, such as Corning Eagle glass, may be doped with at least one of V oxide, Cu oxide, Ti oxide, Fe oxide and Cu to make the glass patch a dark light absorbing glass patch with a relatively lower CTE of from about 35x10⁻⁷ per degree C to about 40x10⁻⁷ per degree C). Alternatively,

only the outer peripheral portion of the glass patch, e.g. the sealing line, may be doped or coated with a light absorbing material or dopant, such as V oxide, Cu oxide, Ti oxide, Fe oxide, Cu or a mixture thereof, such that only the outer peripheral portion (e.g. a sealing line or loop around the edge of the glass patch) is light absorbing.

[0038] In an alternative embodiment hereof, an absorbing glass patch or a glass patch with a light absorbing sealing line (with no loop of frit thereon) is placed over one or more of the fill holes 42 and 44 with the sealing line surrounding one or more of the fill holes as previously described herein. The sealing device is then used to uniformly heat the outer peripheral portion of the absorbing glass patch (e.g. the sealing line) to a substantially equal temperature around the entire periphery of the absorbing glass patch by repeatedly moving the laser beam (or other light or energy beam) quickly around the outer periphery of the glass patch as previously described herein. The laser light is absorbed by and heats the absorbing glass of the glass patch along the sealing line. The outer peripheral/sealing line portion of the absorbing glass patch is thus uniformly heated to a substantially uniform temperature that is high enough to soften or melt the outer periphery of the absorbing glass patch (for example to about 400°C) and thereby fuse the outer peripheral portion of the inner surface of the absorbing glass patch to the second glass plate, thereby attaching the absorbing glass patch to the second glass plate and hermetically sealing the fill hole(s) while minimizing the creation of real time and residual thermal stresses, without heating the electrolyte solution in the cell cavity to a temperature over about 100° C, over about 120°C, or over about 150°C, or in a range from about 100°C to about 120°C.

[0039] Some embodiments disclosed herein describe the sealing of two dissimilar glasses with a goal to encapsulate a hole in one of the glasses. The glass with the hole may be a relatively inexpensive high CTE glass with a CTE in a range of from about 80×10^{-7} to about 90×10^{-7} per C, whereas as the encapsulating glass, e.g. the glass patch, is a relatively low CTE glass with a CTE of less than about 50×10^{-7} per degree C. The sealing processes of embodiments hereof are designed to maintain the temperature in the cell cavity, or on the side of the second glass plate opposite the glass patch, at room temperature, or at least below a slightly elevated temperature limit in a range from about 100° C to about 120° C, or to a temperature not over about 100° C, not over about 120° C or not over 150° C, so as not to detrimentally effect the organic electrolyte solution in the cell cavity. The temperature

limitation is due the heat sensitive organic materials in the organic electrolyte solution contained within the cell cavity that will degrade at higher temperatures. The sealing may be done by uniformly heating the loop of frit or sealing line around the outer periphery of an absorbing glass patch to a temperature above the glass softening or melting temperature of the glass frit or the absorbing glass, as the case may be, so that glass frit or glass softens or melts and can flow and bond to the other glass plate glass. Heating occurs for a relatively short period of time, so that heat doesn't diffuse too far from the sealing line and does not heat the solution or other electrical elements in the cell cavity 40. The laser heats the sealing line to a substantially equal temperature around the entire loop of frit or sealing line in order to minimize thermal gradients and resulting thermal stresses in the frit and glass. As described in more detail hereinafter, this can be achieved by a fast scanning of a focused laser beam with a laser scanner, or by using optics to generate a desired stationary loop-shaped beam that will illuminate the entire loop all at once. The estimated amount of energy required is expected to be the same in either case.

[0040] According to an embodiment hereof, a sealing device 200 for the fast scanning of a laser beam (or other light or energy beam) around the sealing line or frit loop as previously described is illustrated by way of example in Fig. 5. The sealing device 200 includes a source 210 of a concentrated energy or collimated light beam 220, such as a laser. The laser emits a laser beam that is scanned such that the light beam rapidly and repeatedly travels (scans) around sealing line or frit loop (which may be a circular loop or other sharpened loop, such an ellipse, rectangle, etc.) at a relatively high speed, such as in a range from about 1 m/s to about 2m/s, as indicated by the arrow L in Fig. 5. The scanning device may have one or more rotating mirrors 232 and 234 that direct the laser beam 220 along the x and y axis in a known manner. The glass plates and the glass patch may be located on a platen that moves in the x and/or y axis to assist in the scanning, or they may be located on a stationary platen or table. The laser beam may be focused by a telecentric or other lens 240 onto the sealing line. The lens maintains the same laser spot size as the laser beam travels around the sealing line. Fast scanning with a laser quickly and uniformly heats the entire loop of frit or outer periphery of an absorbing glass patch to a substantially even/uniform temperature provided that the scanning period, e.g. the time it takes for the beam to complete one loop or circuit around the sealing line, is less than the time it takes for the temperature of the frit (or sealing

line in an absorbing glass patch) to cool back down below a certain temperature below the peak temperature that is at least somewhat above the temperature of the frit just prior to the just completed circuit around the sealing line.

[0041] Fig. 6 illustrates a possible heating profile according to an embodiment hereof for rapidly and uniformly heating the loop of frit (or absorbing glass patch) to melt the frit and then gradually cooling the frit over at least at least 20- 30 seconds in order to minimize residual stresses in the frit and glass. During a start up phase from T0 to T1, the laser (or other light or energy beam) is quickly ramped up to peak power, such as 10 watts. During a heating or melting phase from T1 to T2, the laser is maintained at peak power for a period of time (the “holding time”) in order to raise the loop of frit to its melting temperature and melt the frit. The holding time or heating phase may be about 3 seconds in length. Rapid heating during the start up and heating phases prevents heat from migrating to the cell cavity and overheating the heat sensitive liquid in the cavity, while substantially uniform heating reduces thermal stresses created in the sealing line, frit loop and glass during heating. Next, during a first cool down phase from time T2 to time T3, the laser power is gradually reduced at a first rate of power reduction down to, for example, 4 watts, in order to gradually cool/lower the temperature of the frit or absorbing glass patch down to its annealing point. During a second cool down phase from time T3 to time T4, the laser power is gradually reduced at a second rate of power reduction, which is slower than the first rate of power reduction, down to zero watts, in order to gradually cool the frit through its strain point. Gradual cooling reduces the amount of residual stresses in the glass and the frit, which is needed the most when sealing two glasses having a CTE mismatch, but is also important when sealing two CTE matched glasses. Another way to minimize real time and residual thermal stresses is to preheat the assembly on heated table (or on hot plate or in an oven) so that the temperature differential between the frit at its peak/melting temperature and the remainder of the assembly, (such as the second glass plate with the hole being sealed and the rest of the glass patch) is less than what it would be without preheating of the assembly. The entire assembly may then be slowly cooled following laser sealing as previously described herein.

[0042] An alternative sealing device 300 for rapidly and uniformly heating the sealing line or frit loop with a stationary loop-shaped beam 320 is illustrated by way of example in Fig. 7.

The alternative sealing device includes a source of a concentrated energy or collimated light beam 210, such as a laser. The laser emits a laser beam 220 that is transformed with special shape axicon or other suitable lens 330 into a hollow cone of light 320. As a result, the laser beam is transformed into an annular, donut or loop shaped beam that corresponds to the shape of the sealing line 340. The lens is spaced from the sealing line by a distance such that the loop-shaped beam is the same size as the sealing line when it impinges upon the sealing line (e.g. the loop of frit or outer periphery of an absorbing glass patch) and the entire frit loop or perimeter of an absorbing glass patch is substantially uniformly heated by the loop-shaped beam. Again, the loop-shaped beam may be any desired looped shape that matches the shape of the sealing line. A mirror may be employed to direct the laser beam through the axicon lens.

[0043] Experiment 1

[0044] A low CTE 2.2 mm thick soda lime glass plate with a hole with approximately 2 mm diameter was used. A glass patch was doped with vanadium oxide and copper oxide to make it a dark light absorbing glass patch with a relatively low CTE of approximately 35×10^{-7} per degree C. A focused laser beam was moved at a relatively slow speed of 10 mm/s at a power of 4 Watts in single pass around the sealing line in order to melt the absorbing glass and attach and seal the glass patch to the glass plate in a single pass. The resulting sample didn't have any visible cracks and appeared to be strong. The sample was subjected to thermal cycling test (-40-85C, 3C/min, 30 min hold, approximately 10 cycles). The sample showed a crack developed during thermal cycling due the presence of residual thermal stress.

Experiment 2

[0045] The same sample glasses as that of Experiment 1 were sealed using a stationary loop-shaped beam. The heating profile was the same as shown in figure 6. In this case, the sealing line and the loop-shaped beam had a diameter of approximately 3 mm diameter. Peak beam power was approximately 11 Watts. The amount of thermal energy deposited to the sample was higher than for first experiment, but the seal area was larger as well. The resulting samples survived thermal cycle and a long term 85° C test without any visible degradation to the seal. The seal was strong. Attempts to separate the glasses broke unsealed portions of the glass, but sealed area stayed intact. Gradual cooling of the seal around the strain point of the

glass with the lower strain temperature was shown to reduce the amount of residual stresses, even in glasses having a CTE mismatch.

[0046] Experiments with soda lime glass patches with a CTE matching that of a soda lime glass plate with the hole being sealed produced cracks during sealing, even with longer cool down times. This suggests that transient stresses in this case were too high to hold the seal together. Another experiment using soda lime glass plates and a relatively low CTE glass patch produced good results when the glass patches had a thickness of about 0.7 mm or less and a heating profile with slow cooling as illustrated in Fig. 6 was used. In the case of sealing the holes with relatively lower CTE glass patches, the frit sealing may not require any special heating profile management. These experiments show that a relatively low CTE glass patches performs better, even when sealing a hole in a relatively high CTE glass plate, than sealing with a soda lime glass patch.

[0047] Embodiments describe herein provide a process for encapsulating and sealing of a relatively small hole (<2 mm) in soda lime glass (or other relatively high CTE glass with a CTE of about $80-90 \times 10^{-7}$ per degree C) with a relatively low CTE glass patch using either light absorbing frit sealing or a light absorbing glass patch. The process forms an inorganic, hermetic, mechanically stable seal. Advantages of the disclosed process and resulting sealed glass package include: a hermetic seal with low residual stress, mechanical stability; no leaks of the solution in the cell cavity; and a relatively long sealed life for the sealed package.

[0048] Embodiments describe herein provide a method of hermetically sealing a fill hole in a glass package, the glass package including a first glass plate and a second glass, an outer peripheral portion of the first glass plate being attached and sealed to an outer peripheral portion of the second glass plate, with the first glass plate spaced from the second glass plate defining a cell cavity between the first glass plate and the second glass plate, at least one fill hole passing through the second glass plate in communication with the cell cavity, the cell cavity being filled with a heat sensitive liquid, the method comprising the steps of: obtaining a glass patch having an inner surface and an outer surface and a loop-shaped sealing line on the inner surface of the glass patch; placing the inner surface of the glass patch on an outer surface of the second glass plate over the at least one fill hole with the sealing line surrounding the at least one fill hole; and uniformly heating the sealing line to a substantially uniform temperature at least as high as a melting temperature of the sealing line to melt the

sealing line and thereby hermetically seal the fill hole with the glass patch without heating the heat sensitive liquid to a temperature over of about 150°C.

[0049] The first and second glass plates may have a CTE in a range from about 80×10^{-7} to about 90×10^{-7} per degree C. The glass patch may have a CTE of less than about 50×10^{-7} per degree C. The glass patch may have a thickness of less than about 0.7mm. The first and second glass plates may have a thickness of more than about 2.2mm. The first and second glass plates may be soda lime glass plates.

[0050] The uniformly heating step may melt the sealing line without heating the organic electrolyte solution to a temperature over of 120°C. The step of uniformed heating may be performed by heating the sealing with a focused beam of light.

[0051] The sealing line may be formed of light absorbing glass frit. Alternatively, the sealing line may be formed by doping the glass patch with at least one of V oxide, Cu oxide, Ti oxide, Fe oxide and Cu at least along the sealing to make at least the sealing line light absorbing glass. Also, the second glass plate may be formed of a dark glass having a composition that includes by weight percentage a composition including 54.92% SiO₂, 5.93% Al₂O₃, 23.27% B₂O₃, 0.43% Li₂O, 1.92% K₂O, 3.25% Fe₂O₃, 6.13% CuO, 2.64% V₂O₅, 1.48% Cl, such that the sealing line is light absorbing.

[0052] The focused beam of light may be a laser beam that is rapidly and repeatedly scanned around the sealing line at a speed of from about 1m/s to about 2m/s. The sealing line may be formed of light absorbing glass frit that has a width of about 0.7mm and the laser beam as a spot size of 1mm.

[0053] The focused beam of light may be a loop shaped beam of light with a size and shape corresponding to the sealing line.

[0054] At least an outer peripheral portion of the glass patch may be formed of a light absorbing glass, and the step of substantially uniformly heating the entire loop of inorganic sealing material is performed by irradiating the sealing line with high intensity light.

[0055] Following the uniformly heating step, there may be a step of gradually cooling the glass package over at least at least 20- 30 seconds. The step of gradually cooling the glass package may include comprises: gradually decreasing a power of the focused light beam at a first rate of power reduction down to gradually lower the temperature of the sealing line down to its annealing point; and gradually decreasing a power of the focused light beam at a

second rate of power reduction that is slower than the first rate of power reduction down to zero power.

[0056] The uniform heating step may include: during a start up phase, quickly ramping the concentrated light beam up to peak power and from T0 to T1; during a heating phase from T1 to T2, maintaining the focused light beam at peak power in order to raise the sealing line its melting temperature. Following the uniformly heating step, there may be a step of gradually cooling the glass package, wherein the gradually cooling step comprises: during a first cool down phase, gradually decreasing a power of the focused light beam at a first rate of power reduction down to gradually lower the temperature of the sealing line down to its annealing point; and during a first cool down phase, gradually decreasing a power of the focused light beam at a second rate of power reduction that is slower than the first rate of power reduction down to zero power.

[0057] The focused light beam may a laser beam with a peak power of 10 watts.

[0058] The sealed glass package may be an organic dye solar cell and the heat sensitive liquid may be an organic electrolyte solution.

[0059] Other embodiments disclosed herein may includes sealed glass package containing heat sensitive liquid comprising: a first glass plate and a second glass, an outer peripheral portion of the first glass plate being attached and sealed to an outer peripheral portion of the second glass plate, with the first glass plate spaced from the second glass plate defining a cell cavity between the first glass plate and the second glass plate, at least one fill hole passing through the second glass plate in communication with the cell cavity, the cell cavity being filled with a heat sensitive liquid; a glass patch on an outer surface of the second glass plate over the at least one fill hole, with the outer periphery of the glass patch fused and hermetically sealed to the outer surface of the second glass plate. The outer periphery of the glass patch may be fused and hermetically sealed to the second glass plate by a loop of glass frit. The sealed glass package may be an organic dye solar cell and the heat sensitive liquid is an organic electrolyte solution.

[0060] It will be apparent to those skilled in the art that various modifications and variations can be made without departing from the spirit or scope of the invention.

CLAIMS

1. A method of hermetically sealing a fill hole (42, 44) in a glass package, the glass package including a first glass (12) plate and a second glass plate (14), an outer peripheral portion of the first glass plate (12) being attached and sealed to an outer peripheral portion of the second glass plate (14), with the first glass plate (12) spaced from the second glass plate (14) defining a cell cavity (40) between the first glass plate (12) and the second glass plate (14), at least one fill hole (42, 44) passing through the second glass plate (14), in communication with the cell cavity (40), the cell cavity (40) being filled with a heat sensitive liquid, said method being characterized in that it includes the steps of:

obtaining a glass patch (52, 54) having an inner surface and an outer surface and a loop-shaped sealing line (L) on the inner surface of the glass patch (52, 54);

placing the inner surface of the glass patch (52, 54) on an outer surface of the second glass plate (14), over the at least one fill hole (42, 44) with the sealing line (L) surrounding the at least one fill hole (42, 44); and

uniformly heating the sealing line (L) to a substantially uniform temperature at least as high as a melting temperature of the sealing line (L) to melt the sealing line (L) and thereby hermetically seal the fill hole (42, 44) with the glass patch (52, 54) without heating the heat sensitive liquid to a temperature over 150°C.

2. The method according to claim 1, wherein one or more of:

(a) the first and second glass plates (12 and 14) have a CTE in a range from about 80×10^{-7} to about 90×10^{-7} per degree C;

(b) the glass patch (52, 54) has a CTE of less than about 50×10^{-7} per degree C;

(c) the glass patch (52, 54) has a thickness of less than about 0.7 mm;

(d) the first and second glass plates (12 and 14) have a thickness of more than about 2.2 mm; and

(e) the first and second glass plates (12 and 14) are soda lime glass plates.

3. The method according to claim 1 or 2, wherein the uniformly heating step is performed by heating the sealing line (L) with a focused beam of light in order to melt the sealing line (L) without heating the organic electrolyte solution to a temperature over 120°C.

4. The method according to any one of claims 1 to 3, wherein the sealing line (L) is formed by one of:

(a) light absorbing glass frit;

(b) a glass patch doped with at least one of V oxide, Cu oxide, Ti oxide, Fe oxide and Cu at least along the sealing to make at least the sealing line light absorbing glass; or

(c) a dark glass having a composition that includes by weight percentage a composition including 54.92% SiO₂, 5.93% Al₂O₃, 23.27% B₂O₃, 0.43% Li₂O, 1.92% K₂O, 3.25% Fe₂O₃, 6.13% CuO, 2.64% V₂O₅, 1.48% Cl, such that at least the sealing line (L) is light absorbing.

5. The method according to any one of claims 3 and 4, wherein the focused beam of light has a wavelength that is one of:

(a) outside of the absorbing range of the cell components;

(b) longer than about 750 nm;

(c) longer than about 800 nm;

(d) or longer than about 810 nm.

6. The method according to any one of claims 3 to 5, wherein the focused beam of light is a laser beam that is rapidly and repeatedly scanned around the sealing line (L) at a speed of from about 1 m/s to about 2 m/s.

7. The method according to claim 6, wherein the sealing line is formed of light absorbing glass frit that has a width of about 0.7 mm and the laser beam as a spot size of 1 mm.

8. The method according to any one of claims 3 to 5, wherein the focused beam of light is a loop shaped beam of light with a size and shape corresponding to the sealing line.

9. The method according to any one of claims 1 to 8, wherein at least an outer peripheral portion of the glass patch (52, 54) is formed of a light absorbing glass, and the step of substantially uniformly heating the entire loop of inorganic sealing material is performed by irradiating the sealing line (L) with high intensity light.

10. The method according to any one of claims 1 to 9, wherein, following the uniformly heating step, it further comprises the step of gradually cooling the glass package over at least 20 - 30 seconds.

11. The method according to any one of claims 1 to 10, wherein, following the uniformly heating step, it further comprises the step of gradually cooling the glass package, said gradually cooling step comprising:

gradually decreasing a power of the focused light beam at a first rate of power reduction gradually cooling the sealing line down to its annealing point; and

gradually decreasing a power of the focused light beam at a second rate of power reduction that is slower than the first rate of power reduction down to zero power gradually cooling the sealing line down to room temperature.

12. The method according to any one of claims 1 to 11, wherein the uniform heating step comprises:

during a start up phase, quickly ramping the concentrated light beam up to peak power;

during a heating phase, maintaining the focused light beam at peak power in order to raise the sealing line its melting temperature.

13. The method according to any one of claims 5 to 8, wherein the focused light beam is a laser beam and peak power is 10 watts.

14. The method according to any one of claims 1 to 13, wherein the sealed glass package is an organic dye solar cell and the heat sensitive liquid is an organic electrolyte solution.

15. A sealed glass package containing heat sensitive liquid characterized by:
a first glass plate (12) and a second glass (14), an outer peripheral portion of the first glass plate (12) being attached and sealed to an outer peripheral portion of the second glass plate (14), with the first glass plate (12) spaced from the second glass plate (14) defining a cell cavity (40) between the first glass plate (12) and the second glass plate (14),

at least one fill hole (42, 44) passing through the second glass plate (14) in communication with the cell cavity (40), the cell cavity (40) being filled with a heat sensitive liquid;

a glass patch (52, 54) on an outer surface of the second glass plate (14) over the at least one fill hole (42, 44), with the outer periphery of the glass patch (52, 54) fused and hermetically sealed to the outer surface of the second glass plate (14).

16. The sealed glass package according to claim 15, wherein the outer periphery of the glass patch (42, 44) is fused and hermetically sealed to the second glass plate (14) by a loop of glass frit (30).

17. The sealed glass package according to claim 15 or 16, wherein the sealed glass package is an organic dye solar cell and the heat sensitive liquid is an organic electrolyte solution.

FIG. 1 Prior Art

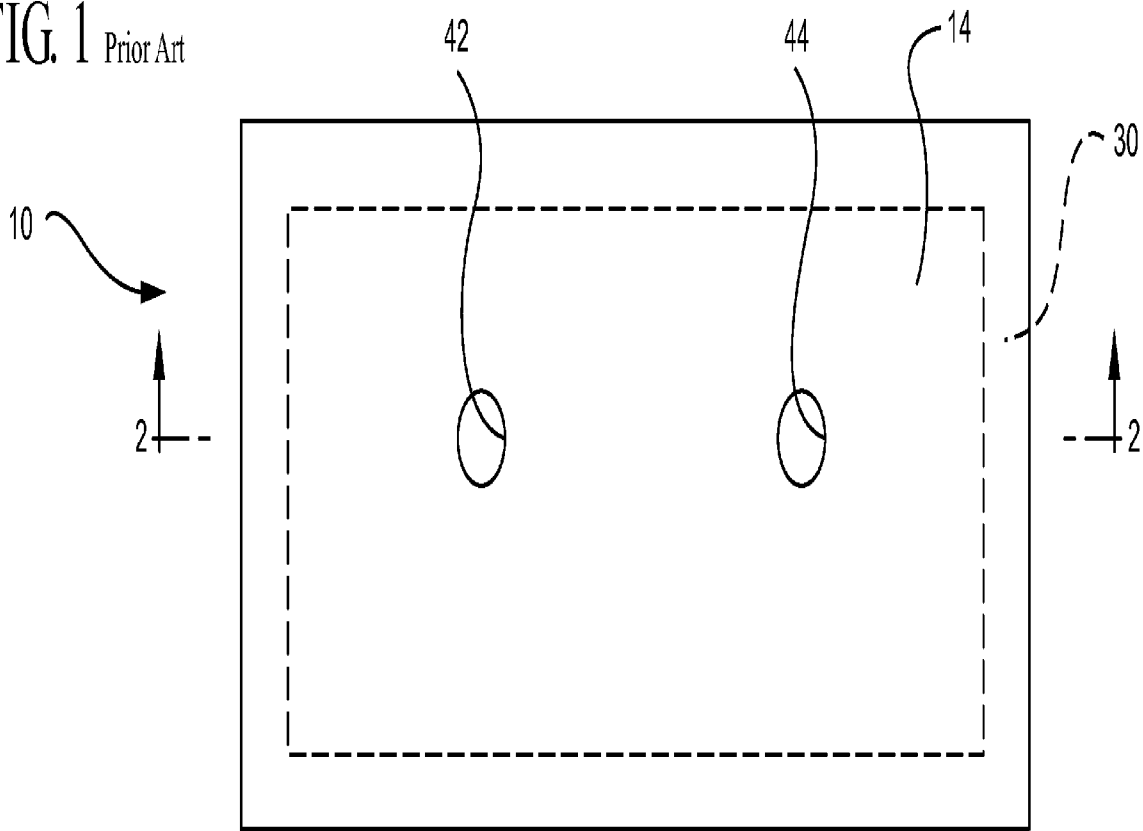
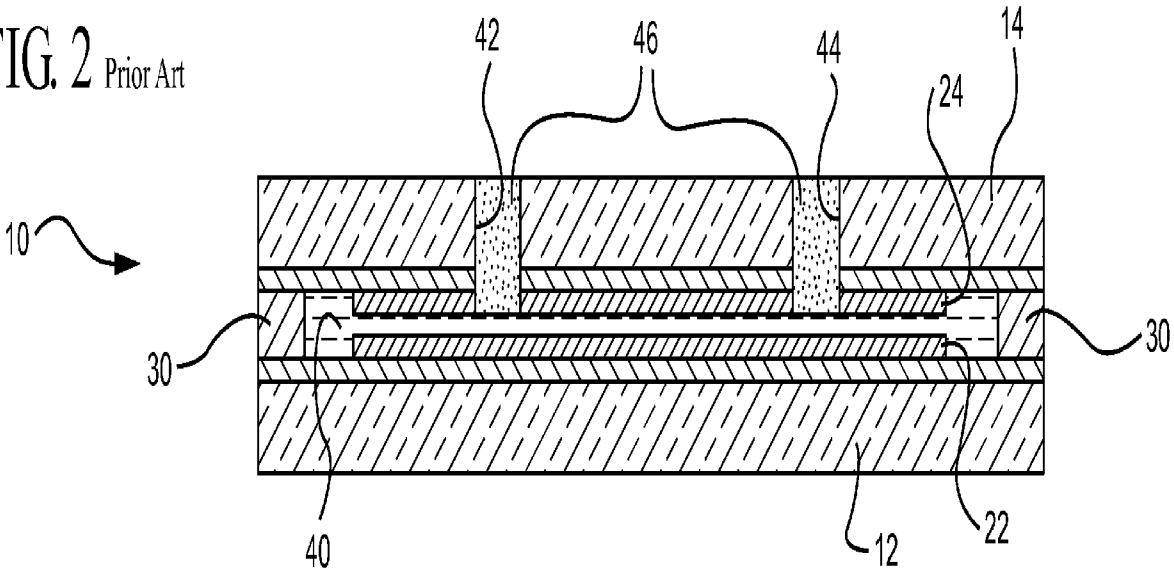

FIG. 2 Prior Art



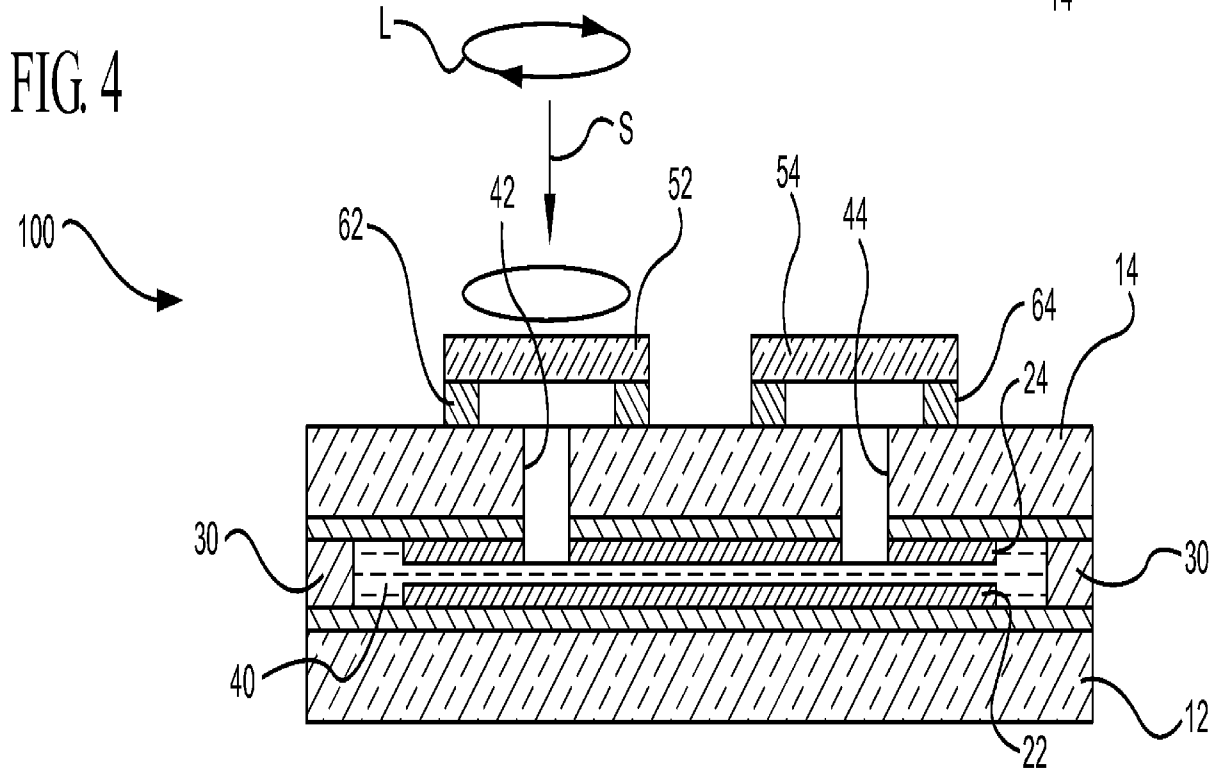
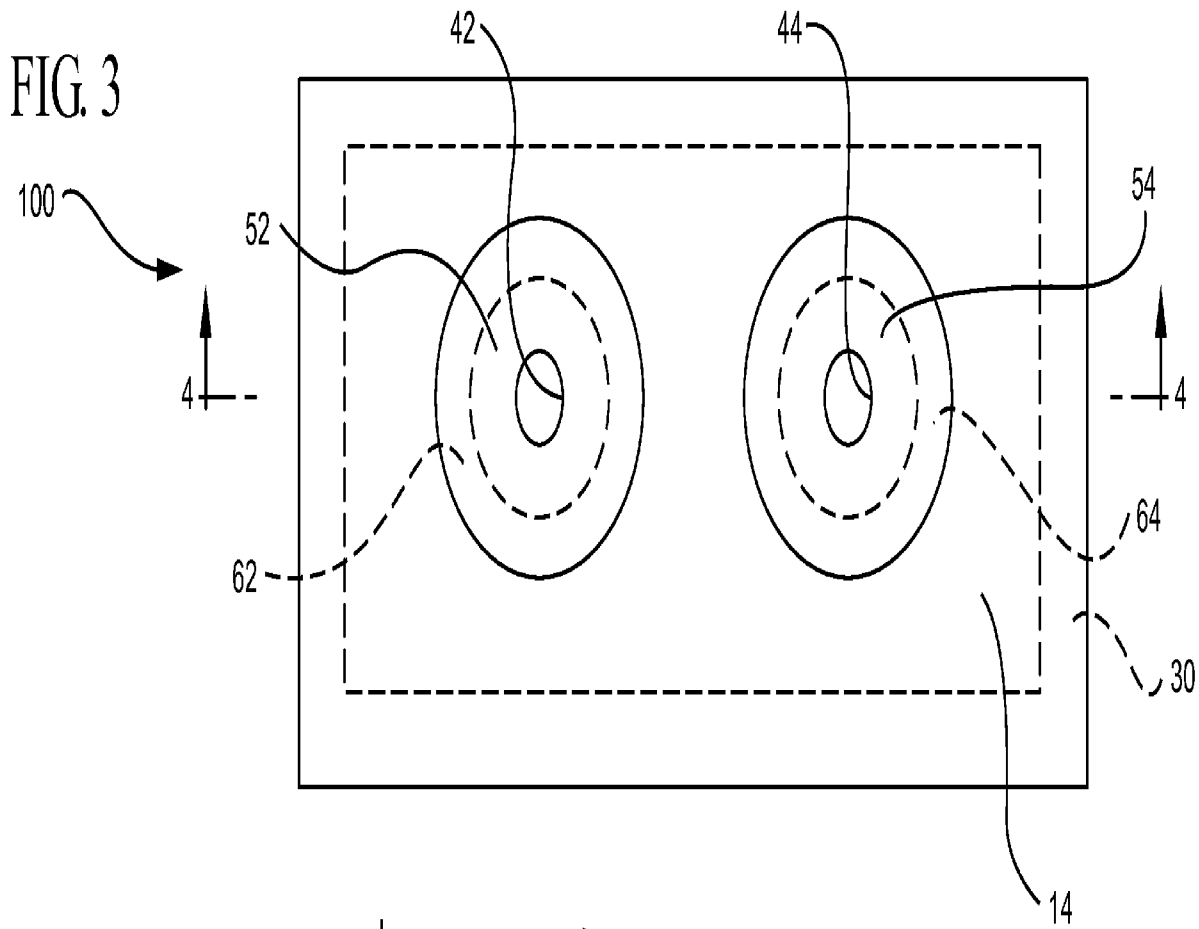

FIG. 5

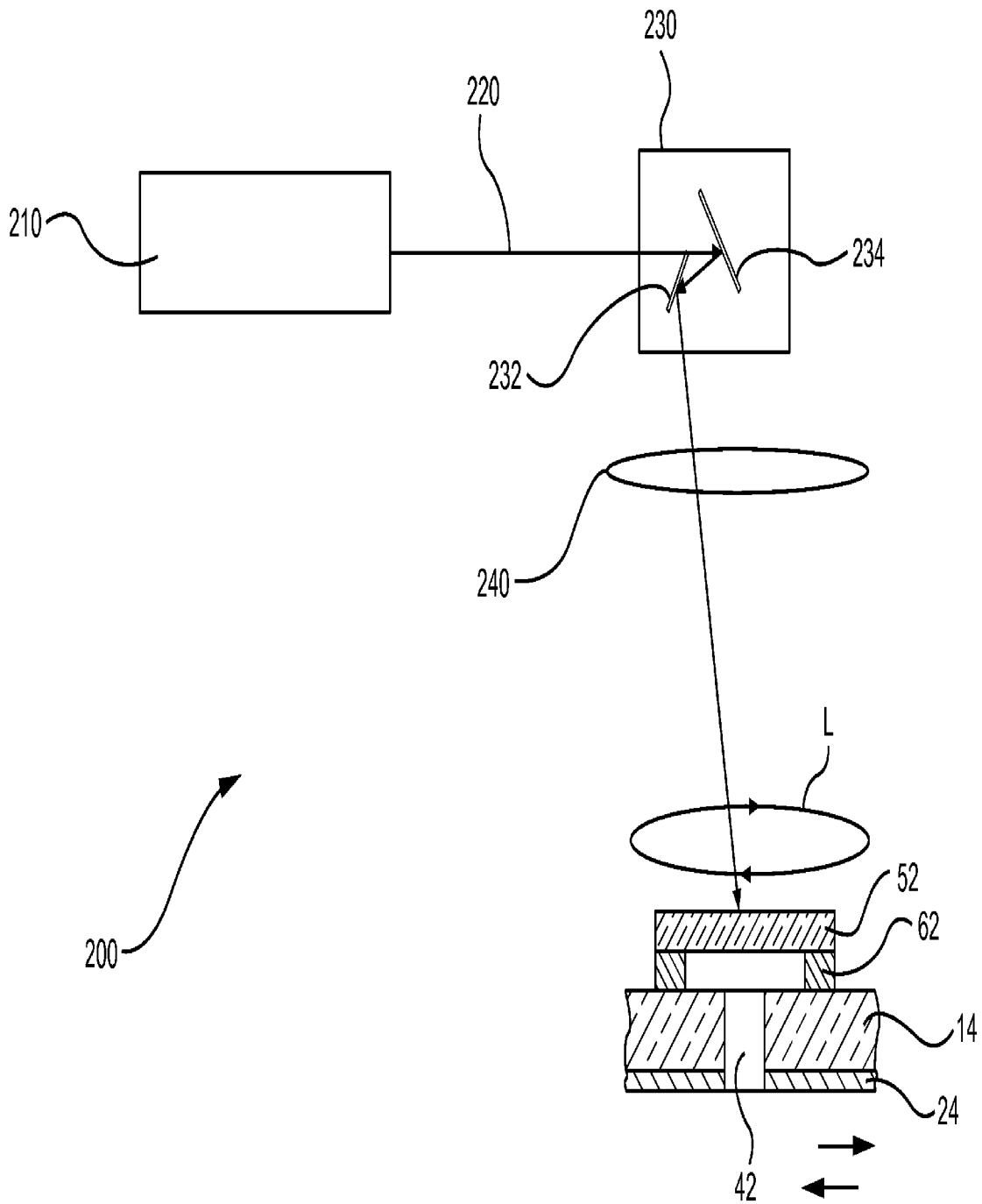

FIG. 6

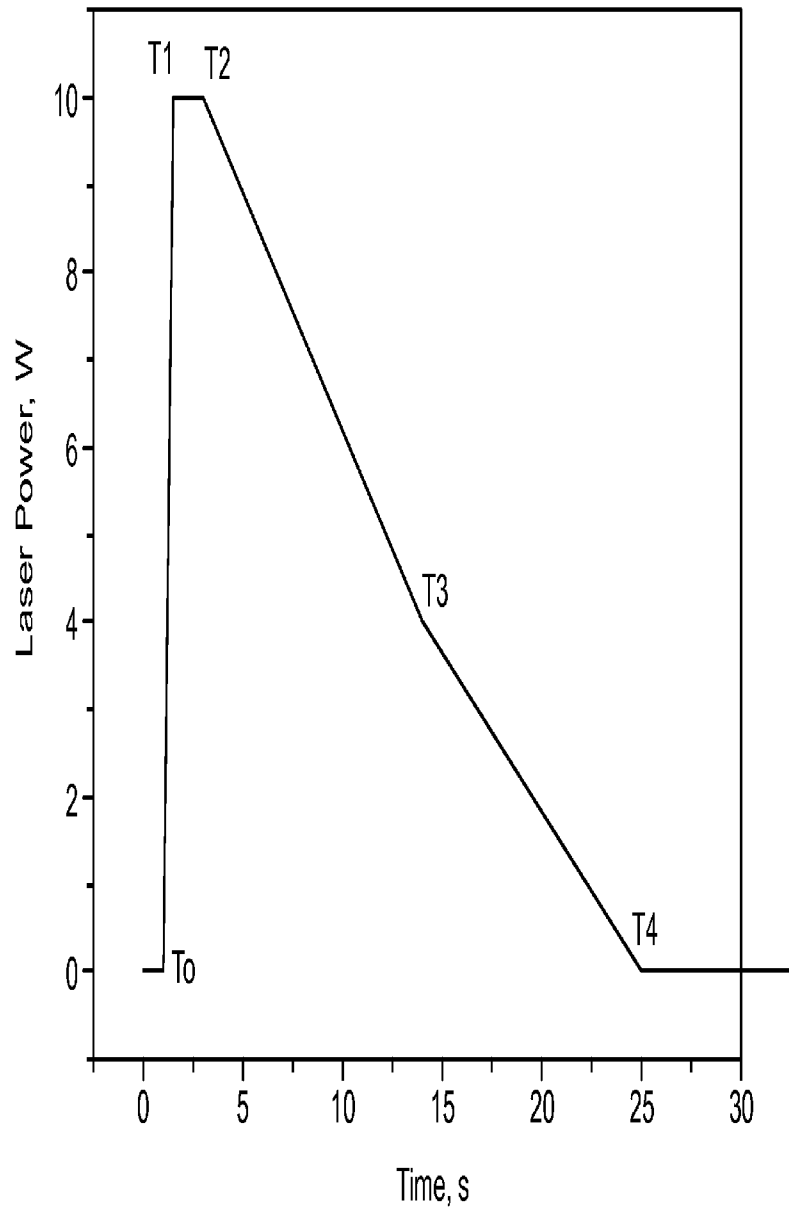
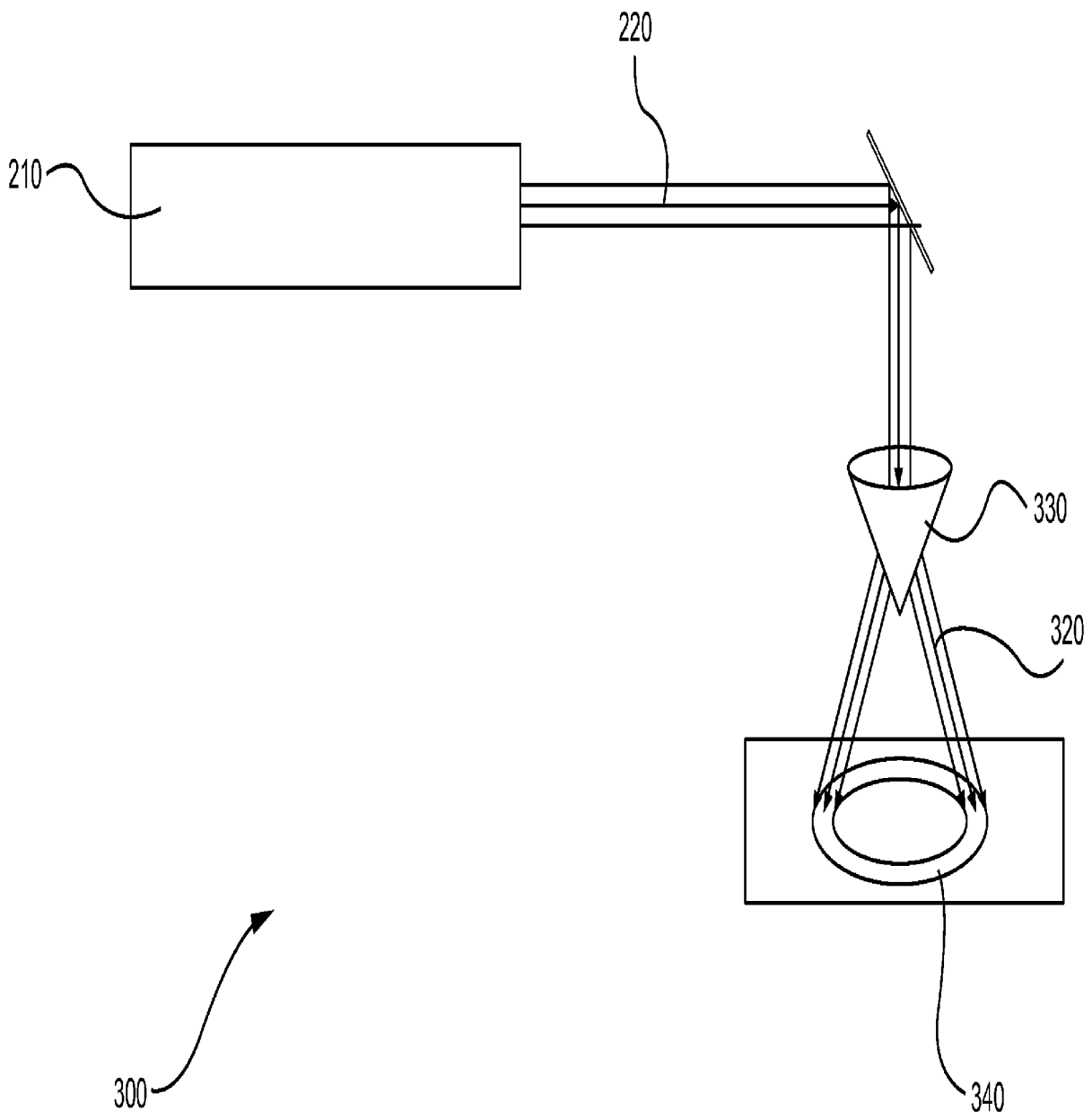

FIG. 7



INTERNATIONAL SEARCH REPORT

International application No

PCT/US2011/049912

A. CLASSIFICATION OF SUBJECT MATTER		
INV. H01G9/20	C03C3/11 C03C4/08 C03C27/06 C03B23/203	
ADD.		
According to International Patent Classification (IPC) or to both national classification and IPC		
B. FIELDS SEARCHED		
Minimum documentation searched (classification system followed by classification symbols)		
H01G H01L C03C C03B		
Documentation searched other than minimum documentation to the extent that such documents are included in the fields searched		
Electronic data base consulted during the international search (name of data base and, where practical, search terms used)		
EPO-Internal, WPI Data		
C. DOCUMENTS CONSIDERED TO BE RELEVANT		
Category*	Citation of document, with indication, where appropriate, of the relevant passages	Relevant to claim No.
X	WO 2010/064213 A1 (EFACEC ENGENHARIA S A [PT]; MAGALHAES MENDES ADELIO MIGUEL [PT]; MAGAL) 10 June 2010 (2010-06-10) paragraphs [0024] - [0027]; claim 1; figure B	1-17
X	WO 2008/093962 A1 (DONGJIN SEMICHEM CO LTD [KR]; LEE CHONG-CHAN [KR]; KIM JONG-BOK [KR];) 7 August 2008 (2008-08-07) paragraphs [0025], [0036]; claim 1; figures	1-17
X	EP 1 137 022 A2 (FUJI PHOTO FILM CO LTD [JP] FUJIFILM CORP [JP]) 26 September 2001 (2001-09-26) paragraphs [0004], [0016], [0099]	1-17
	----- -/--	
<input checked="" type="checkbox"/> Further documents are listed in the continuation of Box C.		<input checked="" type="checkbox"/> See patent family annex.
* Special categories of cited documents :		
"A" document defining the general state of the art which is not considered to be of particular relevance	"T" later document published after the international filing date or priority date and not in conflict with the application but cited to understand the principle or theory underlying the invention	
"E" earlier document but published on or after the international filing date	"X" document of particular relevance; the claimed invention cannot be considered novel or cannot be considered to involve an inventive step when the document is taken alone	
"L" document which may throw doubts on priority claim(s) or which is cited to establish the publication date of another citation or other special reason (as specified)	"Y" document of particular relevance; the claimed invention cannot be considered to involve an inventive step when the document is combined with one or more other such documents, such combination being obvious to a person skilled in the art.	
"O" document referring to an oral disclosure, use, exhibition or other means	"&" document member of the same patent family	
"P" document published prior to the international filing date but later than the priority date claimed		
Date of the actual completion of the international search	Date of mailing of the international search report	
24 October 2011	31/10/2011	
Name and mailing address of the ISA/ European Patent Office, P.B. 5818 Patentlaan 2 NL - 2280 HV Rijswijk Tel. (+31-70) 340-2040, Fax: (+31-70) 340-3016	Authorized officer Flügel, Alexander	

INTERNATIONAL SEARCH REPORT

International application No
PCT/US2011/049912

C(Continuation). DOCUMENTS CONSIDERED TO BE RELEVANT		
Category*	Citation of document, with indication, where appropriate, of the relevant passages	Relevant to claim No.
A	R. SASTRAWAN ET AL.: "New interdigital design for large area dye solar modules using a lead-free glass frit sealing", PROGRESS IN PHOTOVOLTAICS: RESEARCH AND APPLICATIONS, vol. 14, no. 8, 2006, pages 697-709, XP008144509, DOI: 10.1002/pip.700 page 703, paragraph 4 - page 704, paragraph 1	1-17
A	----- US 2005/151151 A1 (HAWTOF DANIEL W [US] ET AL) 14 July 2005 (2005-07-14) cited in the application table 3D	4
A	----- US 2010/059113 A1 (HASEGAWA YUKI [JP] ET AL) 11 March 2010 (2010-03-11) paragraph [0081]; claim 1; figure 1 -----	1-17

INTERNATIONAL SEARCH REPORT

Information on patent family members

International application No PCT/US2011/049912

Patent document cited in search report	Publication date	Patent family member(s)	Publication date
WO 2010064213 A1	10-06-2010	EP 2374142 A1 PT 104282 A	12-10-2011 07-06-2010
WO 2008093962 A1	07-08-2008	CN 101601139 A KR 20080072425 A	09-12-2009 06-08-2008
EP 1137022 A2	26-09-2001	AT 431616 T JP 4443713 B2 JP 2001266963 A	15-05-2009 31-03-2010 28-09-2001
US 2005151151 A1	14-07-2005	CA 2522566 A1 CN 1798708 A EP 1615858 A2 JP 2006524417 A KR 20060011831 A US 2004206953 A1 US 2010186449 A1 US 2005116245 A1 WO 2004094331 A2	04-11-2004 05-07-2006 18-01-2006 26-10-2006 03-02-2006 21-10-2004 29-07-2010 02-06-2005 04-11-2004
US 2010059113 A1	11-03-2010	AU 2007318720 A1 CN 101573827 A EP 2099090 A1 JP 2008140759 A	15-05-2008 04-11-2009 09-09-2009 19-06-2008