

J. J. Morris,

Rotary Pump,

No 54,581,

Patented May 8, 1866.

Fig. 1.

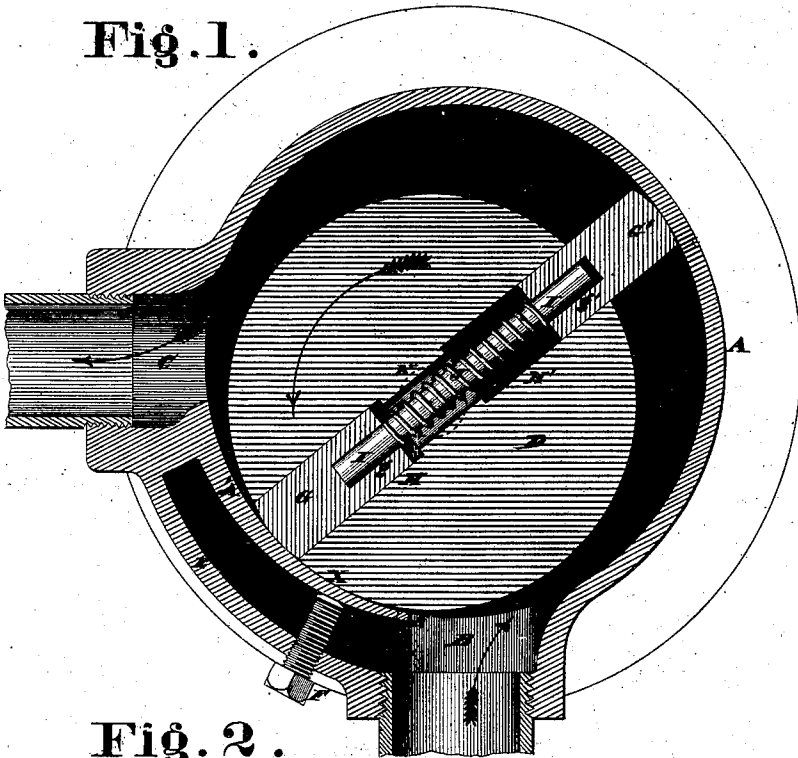
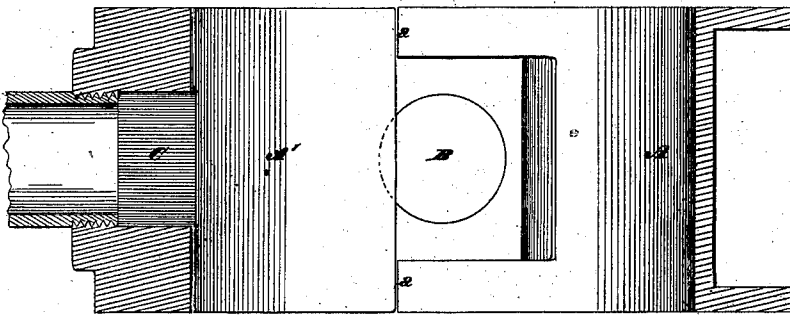

Fig. 2.



Attest,

*Wm. L. Conner
W. Williams*

Inventor.

*John J. Morris
By King & Sons
Atty*

UNITED STATES PATENT OFFICE.

JOHN J. MORRIS, OF CINCINNATI, OHIO.

IMPROVEMENT IN ROTARY PUMPS.

Specification forming part of Letters Patent No. 54,581, dated May 8, 1866.

To all whom it may concern:

Be it known that I, JOHN J. MORRIS, of Cincinnati, Hamilton county, Ohio, have invented certain new and useful Improvements in Rotary Pumps and Engines; and I do hereby declare the following to be a full, clear, and exact description thereof, reference being had to the accompanying drawings, making part of this specification.

My improvements relate to that class of rotary pumps and engines having two or more pistons reciprocating within a head, which revolves eccentrically within a single cylinder; and my invention consists in peculiar devices for packing the revolving head and simplifying the construction of the pistons.

In the accompanying drawings, Figure 1 is a vertical transverse section of a pump or engine embodying my improvements. Fig. 2 is a horizontal section of the same.

A is the stationary cylinder, provided with induction and eduction ports B C for steam or water. D is the revolving piston-head, whose shaft, though concentric with the head, is journaled eccentrically within the stationary cylinder in outside packed bearings in the cylinder-heads.

The periphery of the head D is in contact with the cylinder at the point X, between the supply and discharge pipes, and a perfectly-tight and adjustable joint is secured between the two by means of the elastic tongue A', cast in one piece with the cylinder by coring out the full width of the cylinder at E.

The tongue is separated from the cylinder at *a* by slotting after boring the cylinder, and is by this construction sufficiently elastic to admit of its being forced tightly against the revolving head D by means of the adjustable set screw or screws F. By this device a perfectly-tight joint between the revolving head D and cylinder A through tongue A', can be secured and preserved.

The head D is provided with pistons G G', which have in the revolution of the engine a reciprocating motion within the slots H H'. The pistons and slots are of the entire width of the cylinder.

The pistons are perforated at *g g'* for the insertion of the connecting-pin I, which may be fast in one piston and allowed to slide within the other. The pin I is surrounded by

a single coiled spring, J, designed to set out and pack both pistons.

In all other devices when a revolving head and sliding pistons are used each piston has a separate spring and acts altogether independently of the other, the spring being compressed in each revolution of the engine a distance equal to the difference of diameters between the revolving head and cylinder.

In the device herein described, the pistons being connected and working simultaneously, the spring is only compressed the slight distance equal to the difference between the true diameter of cylinder A on the line A B and its diameter on the line B C.

As a modification of this device, the pin I may be fast in both pistons and elastic gibs fitted into the bearing-edges of the pistons capable of compensating for the difference of diameters.

In working the pump or engine under heavy pressures, the pressure may be introduced under the pistons by surrounding the spring J with a pipe, the pipe passing through a stuffing-box at the aperture K.

The form herein shown and described has been selected as the preferred type of my invention; but various modifications are possible. For example, my improvement may be applied to what is called "double-headed" rotary, having two heads and as many inclosing cylinders or cases, an elastic tongue being provided for each case.

Although I prefer and recommend a set-screw or equivalent appliance to be used, yet for some purposes the screw may be dispensed with, the tongue being set inward by peening or by the application of heat at the back thereof.

I claim herein as new and of my invention—

1. The tapering tongue A', forming part of the cylinder in the described combination, with a set-screw, F, or its equivalent, substantially as described.

2. The connecting pin or pins I, or mechanical equivalent, and coiled spring or springs J, as described, and for the purpose specified.

In testimony of which invention I hereunto set my hand.

Witnesses: JOHN J. MORRIS.

GEO. H. KNIGHT,
JAMES H. LAYMAN.