



- (51) International Patent Classification:  
**B03C 3/76** (2006.01)      **B03C 3/80** (2006.01)  
**B01D 46/12** (2006.01)      **B03C 3/88** (2006.01)
- (21) International Application Number:  
PCT/SE2013/050842
- (22) International Filing Date:  
1 July 2013 (01.07.2013)
- (25) Filing Language:  
Swedish
- (26) Publication Language:  
English
- (30) Priority Data:  
1250749-7      2 July 2012 (02.07.2012)      SE
- (71) Applicant: **MARKETING I KONSULTING PER ANDERS BRATTEMO** [PL/PL]; ul. Kogucia 16/5, PL-30-222 Krakow (PL).
- (72) Inventor; and  
(71) Applicant (for US only): **BRATTEMO, Per Anders** [SE/PL]; ul. Kogucia 16/5, PL-30-222 Krakow (PL).
- (74) Agents: **ÖRTENBLAD, Johan** et al.; NORÉNS PATENTBYRÅ AB, P.O. Box 10198, S-100 55 Stockholm (SE).
- (81) Designated States (unless otherwise indicated, for every kind of national protection available): AE, AG, AL, AM,

AO, AT, AU, AZ, BA, BB, BG, BH, BN, BR, BW, BY, BZ, CA, CH, CL, CN, CO, CR, CU, CZ, DE, DK, DM, DO, DZ, EC, EE, EG, ES, FI, GB, GD, GE, GH, GM, GT, HN, HR, HU, ID, IL, IN, IS, JP, KE, KG, KN, KP, KR, KZ, LA, LC, LK, LR, LS, LT, LU, LY, MA, MD, ME, MG, MK, MN, MW, MX, MY, MZ, NA, NG, NI, NO, NZ, OM, PA, PE, PG, PH, PL, PT, QA, RO, RS, RU, RW, SC, SD, SE, SG, SK, SL, SM, ST, SV, SY, TH, TJ, TM, TN, TR, TT, TZ, UA, UG, US, UZ, VC, VN, ZA, ZM, ZW.

(84) Designated States (unless otherwise indicated, for every kind of regional protection available): ARIPO (BW, GH, GM, KE, LR, LS, MW, MZ, NA, RW, SD, SL, SZ, TZ, UG, ZM, ZW), Eurasian (AM, AZ, BY, KG, KZ, RU, TJ, TM), European (AL, AT, BE, BG, CH, CY, CZ, DE, DK, EE, ES, FI, FR, GB, GR, HR, HU, IE, IS, IT, LT, LU, LV, MC, MK, MT, NL, NO, PL, PT, RO, RS, SE, SI, SK, SM, TR), OAPI (BF, BJ, CF, CG, CI, CM, GA, GN, GQ, GW, KM, ML, MR, NE, SN, TD, TG).

Published:  
— with international search report (Art. 21(3))  
— before the expiration of the time limit for amending the claims and to be republished in the event of receipt of amendments (Rule 48.2(h))



WO 2014/007741 A1

(54) Title: METHOD AND DEVICE FOR BEATING AN ELECTROFILTER

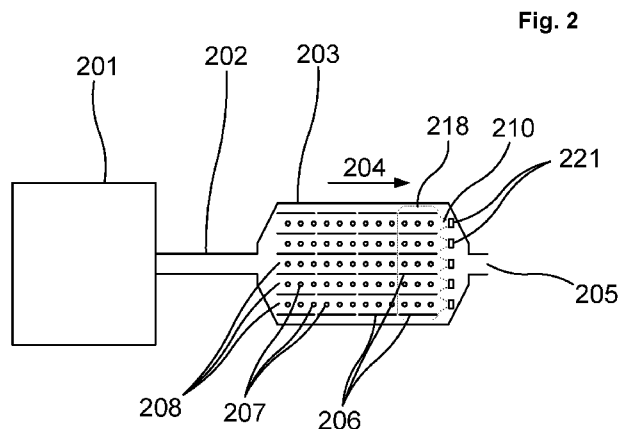

(57) Abstract: Method for use when beating an electro filter (203) comprising at least one emission electrode (207) and at least one precipitation electrode (206), past which precipitation electrode (206) a first gas to be cleaned from particles is caused to stream in a downstream direction (204) in one or several gas passages (208). The invention is characterised in that a stream (210) of a second gas temporarily is applied in the or those gas passages (208) for the first gas that pass the said precipitation electrode (206) while the beating of the precipitation electrode (206) is ongoing, and in that the stream (210) of the second gas is applied from a position downstream of the precipitation electrode (206) and so that it streams in an upstream direction, counter-current to the stream of the first gas, and thereby counteracts the stream of the first gas past the precipitation electrode (206).

## Method and device for beating an electrofilter

The present invention relates to a method and a device for reducing the emission of particles from an electro filter.  
5 More particularly, the invention relates to a method for reducing the redispersion of particles when beating a precipitation electrode in an electro filter.

Flue gases from many industrial processes comprise particulate pollutants. For example, this is the case for different  
10 types of combustion. In order to separate such pollutants, conventionally so called electro filters are used, that use an electric field between an emission electrode and a precipitation electrode to make particles travel to and be captured  
15 by the emission electrode.

This precipitation electrode must regularly be cleansed from collected dust, which can be done by so called beating. Hereby, the precipitation electrode is caused to vibrate, using a  
20 hammer or the like, whereby the dust is released and by gravity falls down into a dust recipient arranged under the electrode, for further treatment or removal.

One problem is that temporary increases of dust emissions  
25 arise during the beating, since dust that is released from the precipitation electrode is redispersed in the flue gas streaming past. This is in particular a problem during beating of the last precipitation electrode in an electro filter device comprising several precipitation electrodes arranged  
30 in series, since there is then no additional downstream precipitation electrode that can capture the particles redispersed during beating of this last precipitation electrode. The part of the total dust emission originating from dust

that is redispersed during beating can amount to as much as about 15 to 20 % of the total dust emissions.

In order to solve this problem, it has been proposed to isolate a precipitation electrode from the flue gas stream while the beating of the electrode in question is performed, for instance using doors that quickly can be lowered from the ceiling on either side of the electrode. Such solutions are complicated, and increase both the investment costs as well as the operating costs for electro filter systems. Moreover, they entail moving parts in the filter part itself, which results in expensive maintenance work.

The present invention solves the described problems.

Hence, the invention relates to a method for use when beating an electro filter comprising at least one emission electrode and at least one precipitation electrode, past which precipitation electrode a first gas to be cleaned from particles is caused to stream in a downstream direction in one or several gas passages, and is characterised in that a stream of a second gas temporarily is applied in the or those gas passages for the first gas that pass the said precipitation electrode during the beating of the precipitation electrode, and in that the stream of the second gas is applied from a position downstream of the precipitation electrode and so that it streams in an upstream direction, counter-directed to the stream of the first gas, and thereby counteracts the stream of the first gas past the precipitation electrode.

In the following, the invention will be described in detail, with reference to exemplifying embodiments of the invention and to the enclosed drawings, in which:

Figure 1 is a cross-sectional top view of a conventional electro filter;

Figure 2 is a cross-sectional top view of an electro filter to which a method according to the present invention can be applied;

Figure 3 is a top view of the electro filter shown in figure 2;

Figure 4 is a detail cross-sectional side view of the electro filter shown in figure 2;

Figure 5 is a detail cross-sectional front view of the electro filter shown in figure 2; and

Figure 6 is a detail view corresponding to the one shown in figure 5, but displaying an alternative embodiment according to the present invention.

15

Figure 1 shows a source 101 for polluted flue gases. The source 101 can be an industrial combustion process for fossil fuels, a chemical process or the like. The flue gases, comprising particulate pollutants, are led via a conduit 102 to a particle separator in the form of a conventional electro filter 103. An electrical field is applied between a number of emission electrodes 107 and a number of precipitation electrodes 106. Particles that are conveyed in the main flow direction 104 of the electro filter 103 are charged in this electrical field, and travel to and are collected at the precipitation electrodes 106.

The precipitation electrodes 106 are arranged in the form of parallel, flat pieces of sheet metal forming between them parallel, elongate gas passages 108 through the electro filter 103. The emission electrodes 107 are arranged in these gas passages 108, between the precipitation electrodes 106. In figure 1, five parallel gas passages 108 are shown, but it is realized that the number may vary between only one gas

passage to a very large number, depending on the embodiment details. Furthermore, there can be several floors of gas passages above one another, perpendicularly to the plane shown in figure 1.

5

The precipitation electrodes 106 are cleaned from collected dust using beating, whereby a hammer or the like during a certain time period causes the electrode in question to oscillate so that the dust thereby is released from the electrode and falls down into a collecting tray or the like, arranged under the electrode.

10

The gas flow through a typical electro filter 103 maintains a velocity of about between 0.5 and 2 m/s. Therefore, a certain share of the released dust has time to be redispersed in the flue gas flow before the dust reaches the collecting tray. This is especially problematic during beating of the most downstream arranged precipitation electrodes, that is the rightmost arranged precipitation electrodes in figure 1, since the dust redispersed there cannot be separated using an additional downstream arranged electrical field and associated precipitation electrodes, but follows the purified flue gases out through the exit 105.

15

20

Using common reference numbers, in figures 2 and 3, respectively, is shown, in cross-sectional top views, an electro filter 203 comprising a device according to the present invention for limiting the redispersion of particles during beating of the electro filter 203. In a way corresponding to that shown in figure 1, a source 201 of polluted gases emits particle-containing flue gases that are led through a conduit 202 to the electro filter 203. The electro filter 203 furthermore comprises a number of emission electrodes 207 and a number of precipitation electrodes 206, between which paral-

25

30

lel gas passages 208 for flue gases are formed. The flue gases are led through the electro filter 203 in the main flow direction 204 of the electro filter 203, and finally out through an exit 205.

5

According to the invention, the device comprises a control device 216 and a number of blowing means 221 for application of a counter-directed gas stream at the precipitation electrodes 206. These blowing means comprise nozzles 209 for a gas and supply conduits 219 for supply of gas to the nozzles  
10 209, which is most clearly illustrated in figures 4 and 5.

The nozzles 209 are arranged downstream of the most downstream arranged precipitation electrode in the electro filter  
15 203, and so that a stream 210 of a gas streaming out from the nozzles streams from this position downstream of the precipitation electrodes 206 and in an upstream direction, which direction is counter-directed to the direction 204 in which the flue gases stream through the electro filter 203 through  
20 the gas passages 208. Thereby, the stream of the flue gases past the precipitation electrode is counteracted.

According to the invention, the control device 216 is arranged to temporarily direct gas to each of the blowing means  
25 221 only during the time when beating is performed of the precipitation electrode downstream of which the respective blowing means is arranged, so that the counter-directed gas stream from the blowing means in question is applied in that or those gas passages that run past the precipitation electrode  
30 which for the moment is being beaten.

In figure 2, the nozzles 209 are illustrated arranged essentially centrally in each parallel gas passage 208 which is formed between the respective precipitation electrodes 206,

and the counter-directed stream 210 of gas is applied across essentially the whole width of the gas passage 208. However, it is realized that the nozzles 209 can be positioned in other ways, and that several nozzles can be arranged abreast  
5 of each other in each gas passage, as long as the temporary counter-directed flow according to the invention can be achieved during the beating of the precipitation electrodes 206. Moreover, the blowing means 221 can be designed in other ways than using nozzles 209, in order to apply a stream of  
10 gas to the gas passages 208, such as with elongate slits or the like, as long as such a counter-directed gas stream is achieved. See below for a more detailed discussion on this.

As is clear from figure 3, and according to a preferred embodiment, the blowing means 221 are fed with a share of the  
15 gas that has already past, and thereby has been purified in, the electro filter 203. In this case, the gas is led through a supply conduit 217 from the exit 205, possibly after additional purification- or other processing steps of the flue  
20 gas, via the control device 216, to the blowing means 221. The system of conduits and the connection between the control device 216 and the blowing means 221 can of course be arranged in other ways, as long as the control device 216 can achieve a control of the gas flow from each of the blowing  
25 means 221 to the respective gas passages 208.

According to another preferred embodiment, filtered atmospheric air is instead used as the gas supplied through the blowing means 221. In case this is possible, it is preferred  
30 to use purified flue gas, since it is then often possible to avoid an increase of the gas flow and cooling of the gas. The latter can also result in precipitation of water or acid, and corrosion. Moreover, expensive filter devices for atmospheric air can be avoided.

It is preferred that the control device 216 is arranged to control the blowing means 221 to achieve the counter-directed gas stream in the gas passages surrounding a certain precipitation electrode during the whole time of beating of the electrode in question. Hence, there is a synchronization between the beating mechanism and the achievement of the counter-directed gas stream, preferably arranged as a connection (not shown) between the beating mechanism (not shown either) and the control device 216.

Using the counter-directed gas stream around a precipitation electrode which is beaten, it is achieved that particles that are released from the precipitation electrode will not be able to be redispersed in the flue gas stream and to continue downstream. Instead, the gas cushion formed by the counter-directed gas stream temporarily limits the velocity of the flue gas stream past the precipitation electrode which is being beaten, and a larger share of the dust leaving the electrode in question can fall down for collection under the electrode.

It is preferred that the gas cushion is designed so that the velocity of the flue gas stream is limited in the whole of the or those channels that is or are adjacent to the beaten precipitation electrode.

According to a preferred embodiment, the counter-directed gas stream is maintained during a shorter time period, preferably between 2 and 10 seconds, after the beating of the respective precipitation electrode has ceased. Thereby, also smaller particles will have the time to fall down sufficiently far in order not to be redispersed when the counter-directed gas stream ceases.

As is illustrated in figure 2, and according to a preferred embodiment, the or those precipitation electrodes at which the counter-directed gas stream or streams are achieved are part of an electro filter step 218, denoted in figure 2 using a broken-line bubble, which in turn constitutes the most downstream arranged of several series-connected electro filter steps. The term "electro filter step" herein refers to a series of parallel-connected precipitation electrodes in an electro filter, between which flue gases are arranged to stream in a parallel flow. Hence, an electro filter step can comprise only one precipitation electrode or several such precipitation electrodes, in the latter case arranged abreast of and/or above one another.

In case several precipitation electrodes are arranged in parallel in an electro filter step 218 which is to be beaten, and which is to be provided with a counter-directed gas stream according to the invention during the beating, it is preferred that the precipitation electrodes in the said electro filter step 218 are beaten in turns, preferably one at a time, and that respective counter-directed gas streams are temporarily applied only to that or those gas passages 208 that surround each respective precipitation electrode 206 in the electro filter step which is beaten at the moment. This results in that the total flow of flue gases through the electro filter 203 is not affected more than to a limited extent, because of the counter-directed gas streams at only one or a few of the precipitation electrodes past which the gas streams. Hence, the operation of the electro filter 203 is only disturbed to a limited extend as a consequence of the beating.

According to a preferred embodiment, the counter-directed gas stream from the blowing means 221 is sufficiently powerful to achieve that essentially no particles that during beating have been released from the precipitation electrode at which the counter-directed gas stream is applied can be transported downstream, as a result of the gas stream in combination with pressure waves from the beating of the precipitation electrode, against the counter-directed gas stream, while the beating is ongoing.

10

The smallest gas pressure which is required to achieve this varies with the specific embodiment, but it is possible to determine this using empirical tests. The source of the gas which is applied by the blowing means 221 is hence preferably pressurized, for instance using a conventional fan or compressor (not shown). An advantage with the present invention is that the gas source can be pressurized by conventional, robust and cost-efficient fans, since the pressure required to achieve the herein described gas cushions as a rule is relatively low.

20

Figure 4 schematically shows a side view of a precipitation electrode 206, arranged between the ceiling 211 and the floor 212 of the electro filter 203.

25

According to a preferred embodiment, which is most clearly illustrated in figures 3 and 4, the control device 216 provides the blowing means 221 with gas via a supply conduit 215 and a distribution conduit 214. The distribution conduit 214 distributes the gas to the various distribution conduits 219, each of which provides gas to the nozzles 209 in a respective parallel gas passage 208. In order to control the gas to different blowing means 221, as described above, control means (not shown) controlled by the control device 216 can be

30

installed in the distribution conduit 214, the supply conduits 219 or at the nozzles 209, alternatively several distribution conduits 214 can be connected to the control device 216 with an individual control. Alternatively, each supply  
5 conduit 219 can also be individually connected to the control device 216.

The nozzles 209 are arranged along the whole or essentially the whole of the part, perpendicularly to the flow direction  
10 204 of the flue gases, of the precipitation electrode 206 past which the flue gas stream passes in the gas passage 208 to which the precipitation electrode 206 constitutes a wall. In other words, the nozzles 209 are distributed along the supply conduit 219 so that the gas stream applied by the  
15 nozzles covers essentially the whole vertical downstream arranged side edge of the precipitation electrode 206, so that the resulting air cushion limits the flow velocity of the flue gases along the whole downstream arranged terminating section of the precipitation electrode 206. It is preferred that the counter-directed gas stream is applied along  
20 the whole height of the or those gas passages 208 that surround the precipitation electrode. Moreover, it is preferred that the nozzles 209 are arranged equidistantly and so close together so that a connected or essentially connected air  
25 cushion is formed along the whole downstream terminating section of the precipitation electrode 206.

The corresponding is true if the blowing means 221 are designed in another way than with a series of nozzles 209.  
30 Hence, for instance an elongate slit can be used in the supply conduit 219, which then gives rise to a corresponding, connected vertical air cushion.

Such a design makes it possible for released particles to efficiently be prevented from being redispersed in the flue gas stream along the whole length of the precipitation electrode 206.

5

According to an especially preferred embodiment, illustrated in figures 4 and 5, at least one of the blowing means 221, preferably all blowing means 221, is or are connected to the distribution conduit 214 using a flexible connection 220. The connection between the blowing means 221 and the distributions conduit 214 in this case runs through a lead-through 213 in the cover of the electro filter 203, preferably through its ceiling 211. Thereby, the advantages of the device according to the present invention arranged inside the electro filter 203, that is the supply conduit 219 and the nozzles 209 in the embodiment illustrated in figure 4, move independently of the parts of the device according to the present invention that are arranged outside of the cover of the electro filter 203, hence in figure 4 the conduit system 214, 215, 216, the control device 216, etc.

In other words, several blowing means 221 are connected, using such flexible connections 220, to a main distribution device, comprising the distribution conduit 214, which is arranged outside of the cover of the electro filter 203. The main distribution device is in turn, via the control device 216, connected to a central source for the gas to be supplied through the blowing means 221. This achieves a cheap and robust construction which is not negatively affected by relative motions arising as a result of varying operation temperatures inside the electro filter 203.

Moreover, in this case at least all active or moving parts of the control system for supplying the counter-directed gas

stream to the correct gas passages 208, in figure 4 that is the control device 216 as well as at least the parts of the remaining conduits 215, 217 that comprise control drives, controllable valves or the like, as well as preferably also  
5 active components such as compressors, fans and the like for achieving compressed gas, etc., are arranged outside of the cover of the electro filter 203, preferably on top of the roof 211 of the electro filter 203. It is especially preferred that the parts of the supply system for the counter-directed  
10 gas flow which are arranged inside the electro filter 203 are completely constituted by passive components with no moving parts. Such an arrangement admits simple and cheap maintenance of the system, since the parts normally requiring maintenance are arranged so that the cover of the electro  
15 filter 203 needs not be opened or demounted for access.

According to a preferred embodiment, the precipitation electrodes 206 are in the form of vertical pieces of sheet metal, and the supply conduits 219 extend vertically along the precipitation electrodes 206. Such an arrangement admits an  
20 uncomplicated but efficient construction. Figure 5 illustrates a first preferred embodiment, in which the blowing means 221 in order to apply the counter-directed gas stream are arranged in parallel with the precipitation electrodes  
25 206 and centrally arranged in each respective gas passage 208 between the precipitation electrodes 206. Hence, each blowing means 221 achieves a counter-directed gas stream creating a gas cushion along the two respective sides of the precipitation electrodes 206 surrounding each respective gas passage  
30 208. During beating of a certain precipitation electrode, the two blowing means that are arranged on each side of the precipitation electrode in question are hence caused to be activated during the beating.

An alternative or supplementary embodiment is illustrated in figure 6, which is similar to the embodiment illustrated in figure 5. 304 illustrates the main flow direction of the flue gas stream. In contrast to in figure 5, in figure 6 the blowing means 321 for application of the counter-directed gas streams are arranged in the extension of a respective precipitation electrode 306 each in the direction 304. Hence, the counter-directed gas stream achieved by each blowing means 321 will be present on both sides of the respective precipitation electrode 306, whereby only one blowing means 321 needs to be activated during the beating of a certain precipitation electrode.

Hence, the present invention achieves, using simple and cheap means, a robust system for decreasing the emissions of particulate pollutants from electro filters. Moreover, an existing electro filter can easily be supplemented with a redispersion decreasing device according to the present invention, and thereby achieve the said emission decrease without having to replace or to large parts rebuild the existing electro filter, which often requires large investments in additional electrical systems.

Above, preferred embodiments have been described. However, it is apparent to the skilled person that many modifications can be made to the described embodiments without departing from the basic idea of the invention.

For instance, the counter-directed gas stream can be achieved in other ways than using nozzles or slits, as long as a counter-directed gas stream is achieved around an precipitation electrode which is being beaten, so that the redispersion of released particles decreases or is prevented.

Moreover, the blowing means can be designed with nozzles, slits or the corresponding, arranged to apply a counter-directed gas stream with different force at different heights along the downstream arranged terminating section of the beaten precipitation electrode. For instance, a more powerful gas cushion can be achieved further down along the precipitation electrode, which results in that a better protection to redispersion can be achieved near the bottom of the precipitation electrode, where the density of released particles is higher than close to the upper parts of the precipitation electrode.

In a corresponding way, the counter-directed gas stream can be maintained during a more extended time period at positions further down along the beaten precipitation electrode as compared to positions further up, so that smaller particles are prevented from redispersing at the same time as the flue gas stream is again allowed to pass at an earlier time further up along the precipitation electrode, where the density of released particles is lower.

Moreover, other precipitation electrodes, except the most downstream arranged ones, can also be subjected to a counter-directed gas stream while the beating of such precipitation electrodes is ongoing.

Hence, the invention is not to be limited by the described embodiments, but can be varied within the scope of the enclosed claims.

**C L A I M S**

1. Method for use when beating an electro filter (203) comprising at least one emission electrode (207) and at least one precipitation electrode (206), past which precipitation electrode a first gas to be cleaned from particles is caused to stream in a downstream direction (204) in one or several gas passages (208), where a stream (210) of a second gas is caused to be temporarily applied in the or those gas passages (208) for the first gas that pass the said precipitation electrode (206) while the beating of the precipitation electrode (206) is ongoing, and where the stream (210) of the second gas is caused to be applied from a position downstream of the precipitation electrode (206) and so that it streams in an upstream direction, counter-directed to the stream of the first gas and thereby counteracting the stream of the first gas past the precipitation electrode (206), **characterised in** that the stream of the second gas is caused to be applied using at least one blowing means (221) centrally arranged in a respective gas passage (208) between the precipitation electrodes (206).

2. Method according to claim 1, **characterised in** that the second gas is constituted by a share of the first gas which has already passed the electro filter (203).

3. Method according to any one of the preceding claims, **characterised in** that the precipitation electrode (206) is a part of an electro filter step (218) which in turn constitutes the most downstream arranged of several series-connected electro filter steps.

4. Method according to any one of the preceding claims, **characterised in** that the precipitation elec-

trode (206) is a part of an electro filter step (218) comprising several arranged precipitation electrodes arranged in parallel and that are beaten in turns, and in that a respective stream or several respective streams (210) of the second gas is or are caused to temporarily be applied to the or those gas passages (208) that surround each respective precipitation electrode which is being beaten at the moment.

5  
10  
15  
20  
25  
30  
5. Method according to any one of the preceding claims, **characterised in** that the stream (210) of the second gas is sufficiently powerful so that essentially no particles that have been beaten off from the precipitation electrode (206) as a result of the stream of the first gas in combination with pressure waves from the beating of the precipitation electrode (206) while the beating is ongoing will be able to be transported downstream, against the stream (210) of the second gas.

6. Method according to any one of the preceding claims, **characterised in** that the electro filter (203) is an existing electro filter which is supplemented with a control device (216) and blowing means (221) in order to achieve the said stream (210) of the second gas.

7. Device for limiting the redispersal of particles when beating an electro filter (203), which electro filter (206) comprises at least one emission electrode (207) and at least one precipitation electrode (206), past which precipitation electrode (206) one or several gas passages (208) are arranged to lead a first gas to be cleaned from particles, where the device comprises a control device (216) and at least one blowing device (221) for applying a stream (210) of a second gas, from a position downstream of the precipitation electrode (206) in the or those gas passages (208) for the

first gas that pass the said precipitation electrode (206), where the blowing means (221) is arranged to apply the stream (210) of the second gas so that it streams in an upwards direction, counter-directed to the stream of the first gas, and where the control device (216) is arranged to control the said blowing means (221) to temporarily apply the said stream (210) of the second gas while the beating of the precipitation electrode (206) is ongoing, **characterised in** that the blowing means (221) is centrally arranged in a respective gas passage (208) between the precipitation electrodes (206).

8. Device according to claim 7, **characterised in** that the precipitation electrode (206) is a part of an electro filter step (218) which in turn constitutes the most downstream arranged of several series connected electro filter steps.

9. Device according to claim 7 or 8, **characterised in** that the precipitation electrode (206) is a part of an electro filter step (218) comprising several precipitation electrodes, arranged in parallel, that are beaten in turns, and in that the control device (16) is arranged to control one or several respective of said blowing means (221) to temporarily apply a respective stream or respective streams to the or those gas passages (208) that surround each respective precipitation electrode (206) which is being beaten at the moment.

10. Device according to any one of claims 7-9, **characterised in** that at least one of said blowing means (221) is arranged to apply the stream (210) of the second gas along substantially the whole part, perpendicularly to the flow direction (204) of the first gas, of the precipitation

electrode (206) past which part the first gas passes in the gas passage (208).

11. Device according to any one of claims 7-10, **characterised in** that at least one of said blowing means (221) is connected, using a flexible connection (220), to a main distribution device (214) arranged outside of the electro filter (203), and in that the main distribution device (214) is connected to a central source of the second gas.

10 12. Device according to claim 10 or 11, **characterised in** that the precipitation electrodes (206) are in the form of vertical pieces of sheet metal, and in that at least one of the blowing means (221) extends vertically, in parallel to and between the precipitation electrodes (206).

13. Device according to any one of claims 7-12, **characterised in** that at least one of the blowing means (221) comprises a plurality of nozzles (209), arranged one next to the other, for distributing the stream (210) of the second gas.

14. Device according to any one of claims 7-12, **characterised in** that at least one of the blowing means (221) comprises an elongated slit for distributing the stream (210) of the second gas.

15. Filtering device for separating particulate pollutants from a gas, **characterised in** that the filtering device comprises an electro filter (203) as well as a device according to any one of claims 7-14 for limiting the redispersal of the particulate pollutants that are captured by the said electro filter (203) during beating of at least one precipitation electrode (206) in the electro filter (203).

Fig. 1

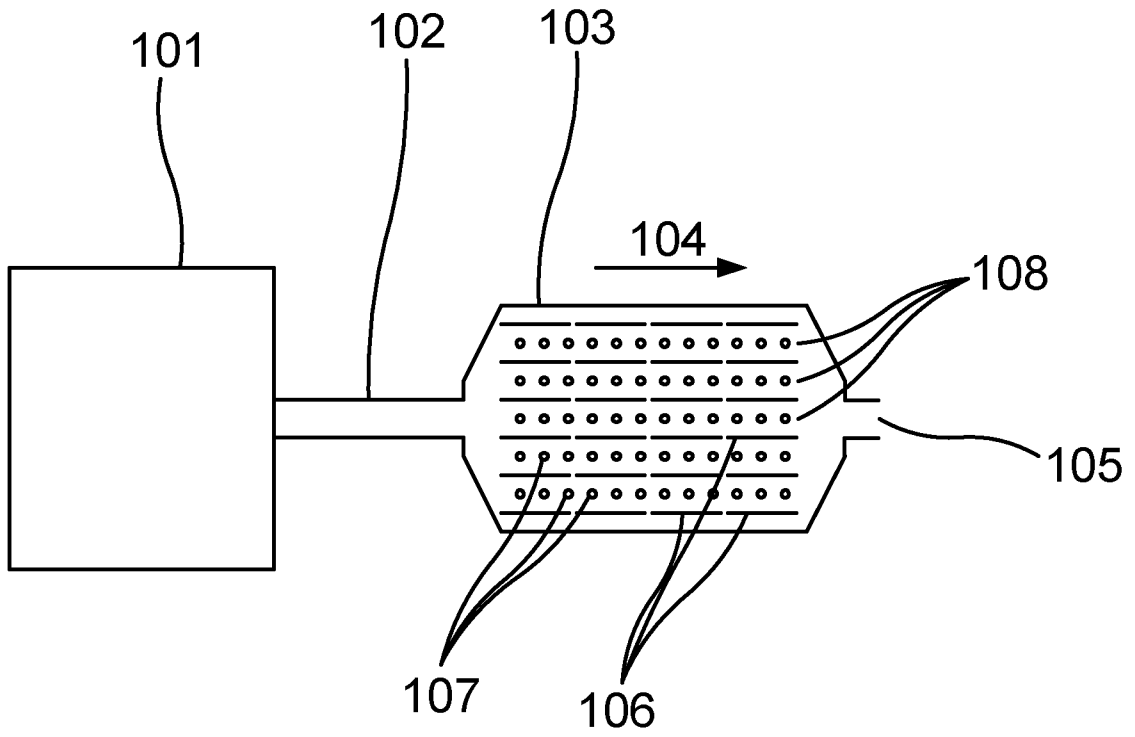

Fig. 2

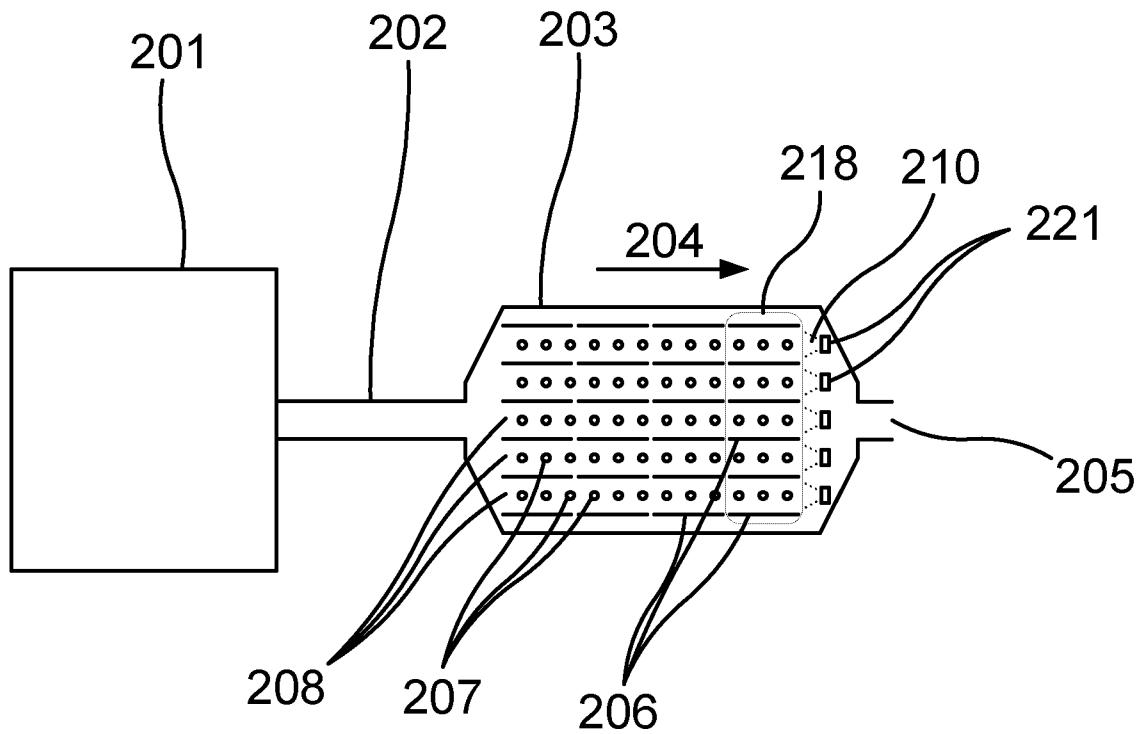
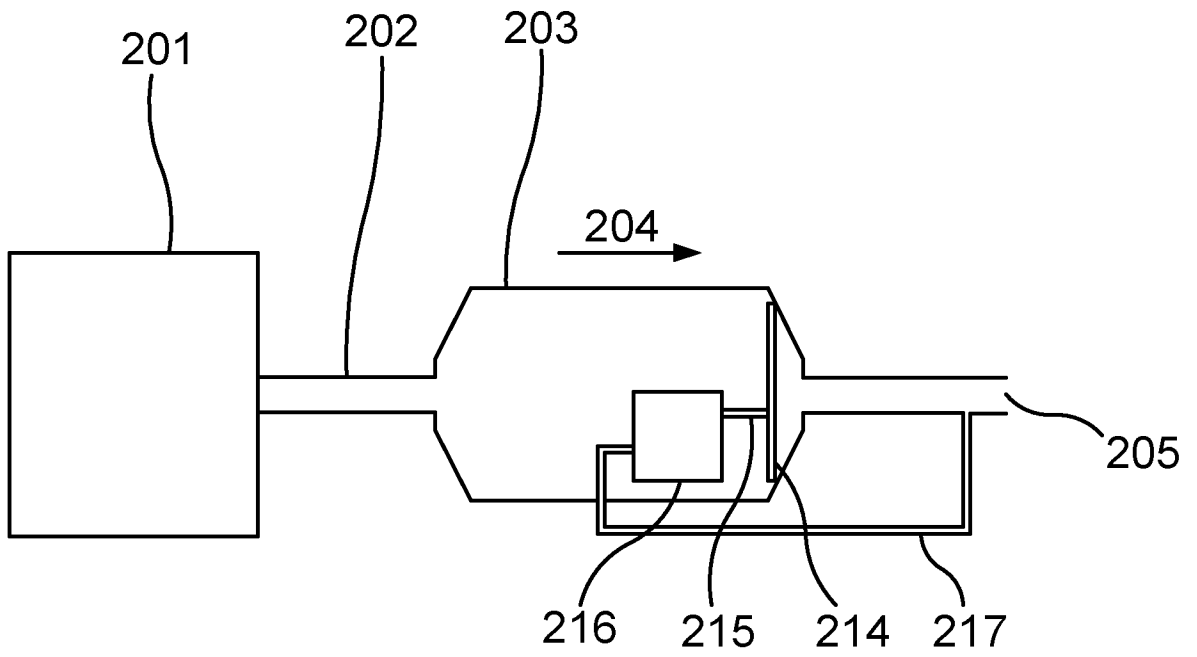
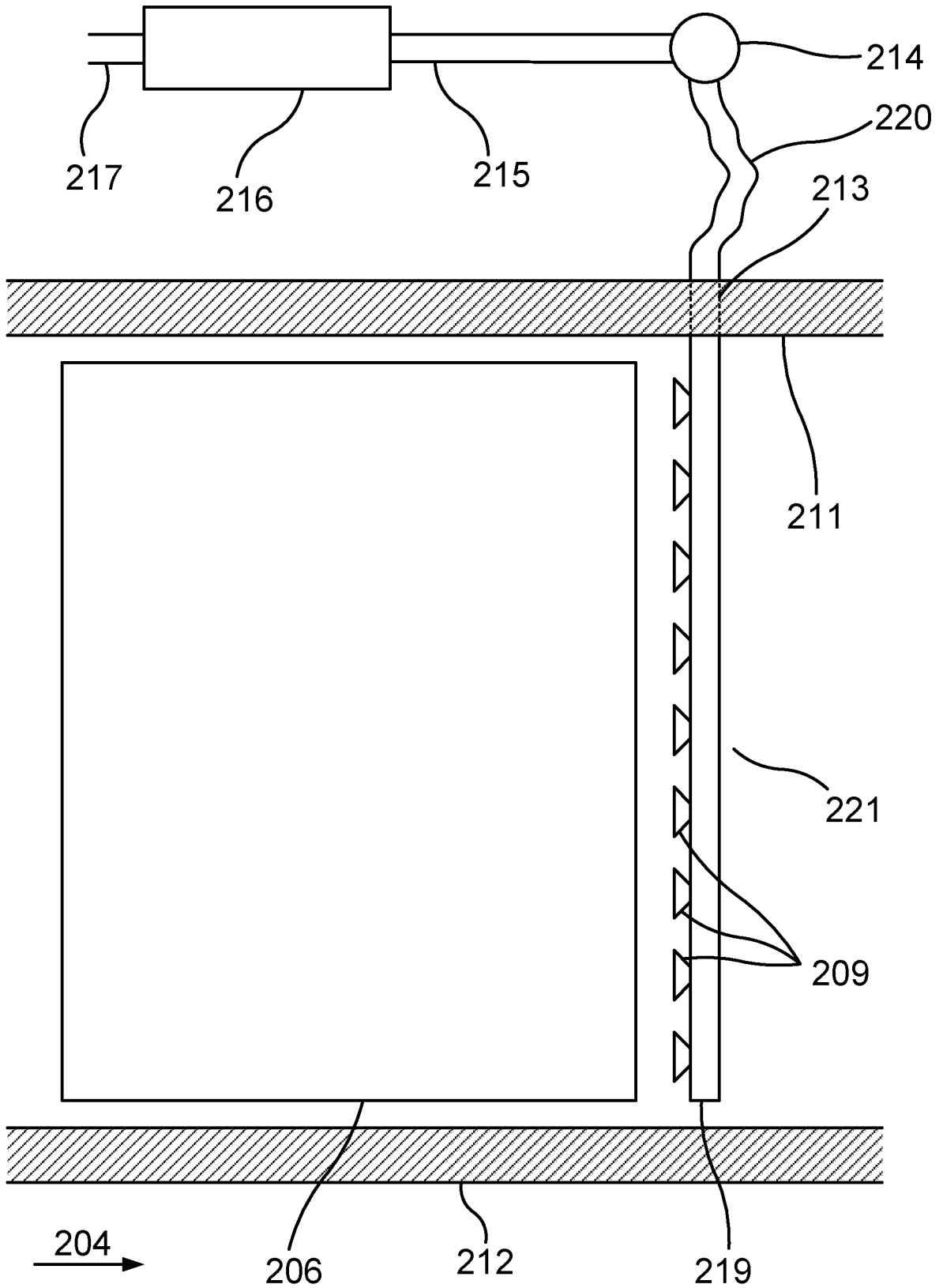

Fig. 3



3/5

Fig. 4



4/5

Fig. 5

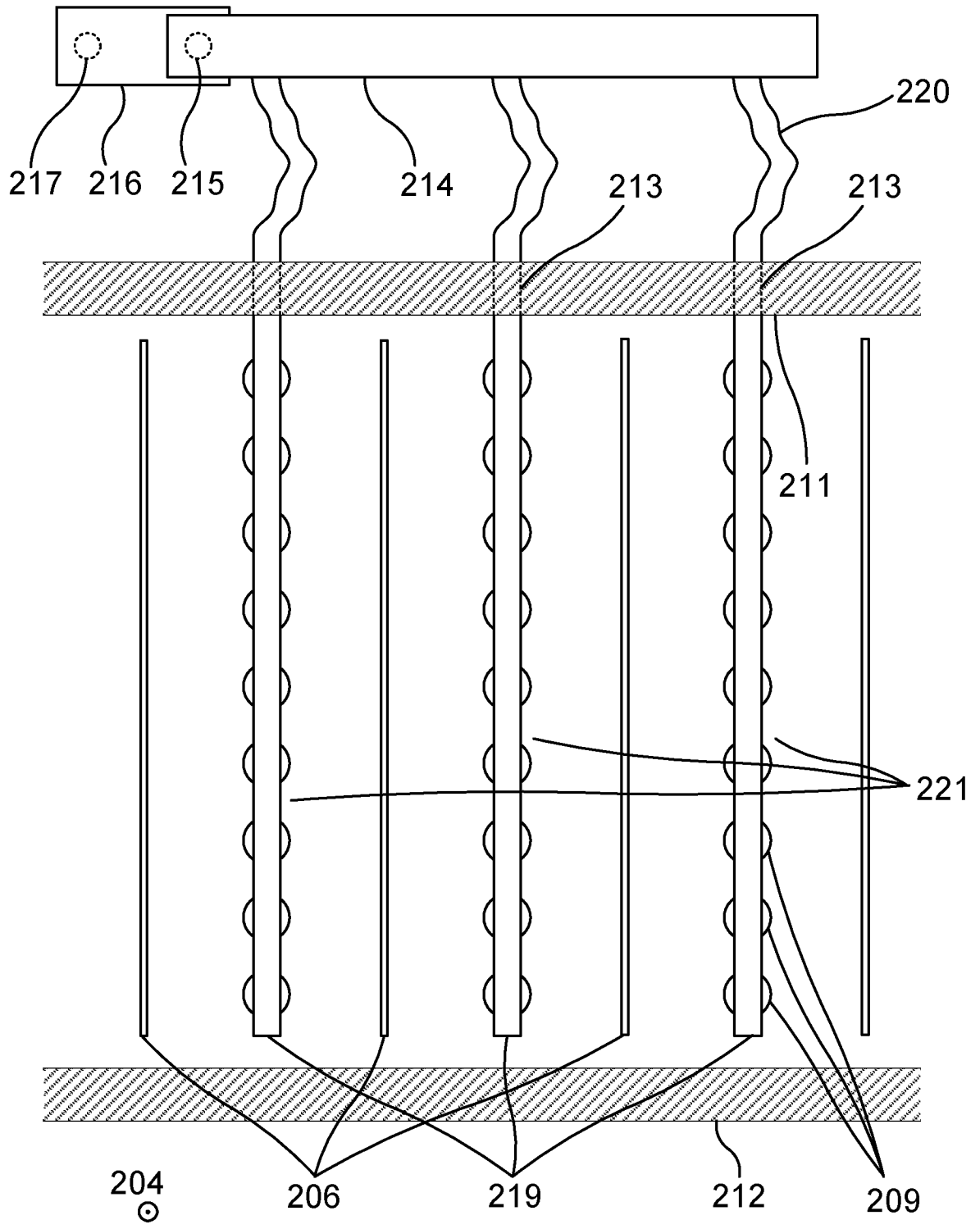

5/5

Fig. 6

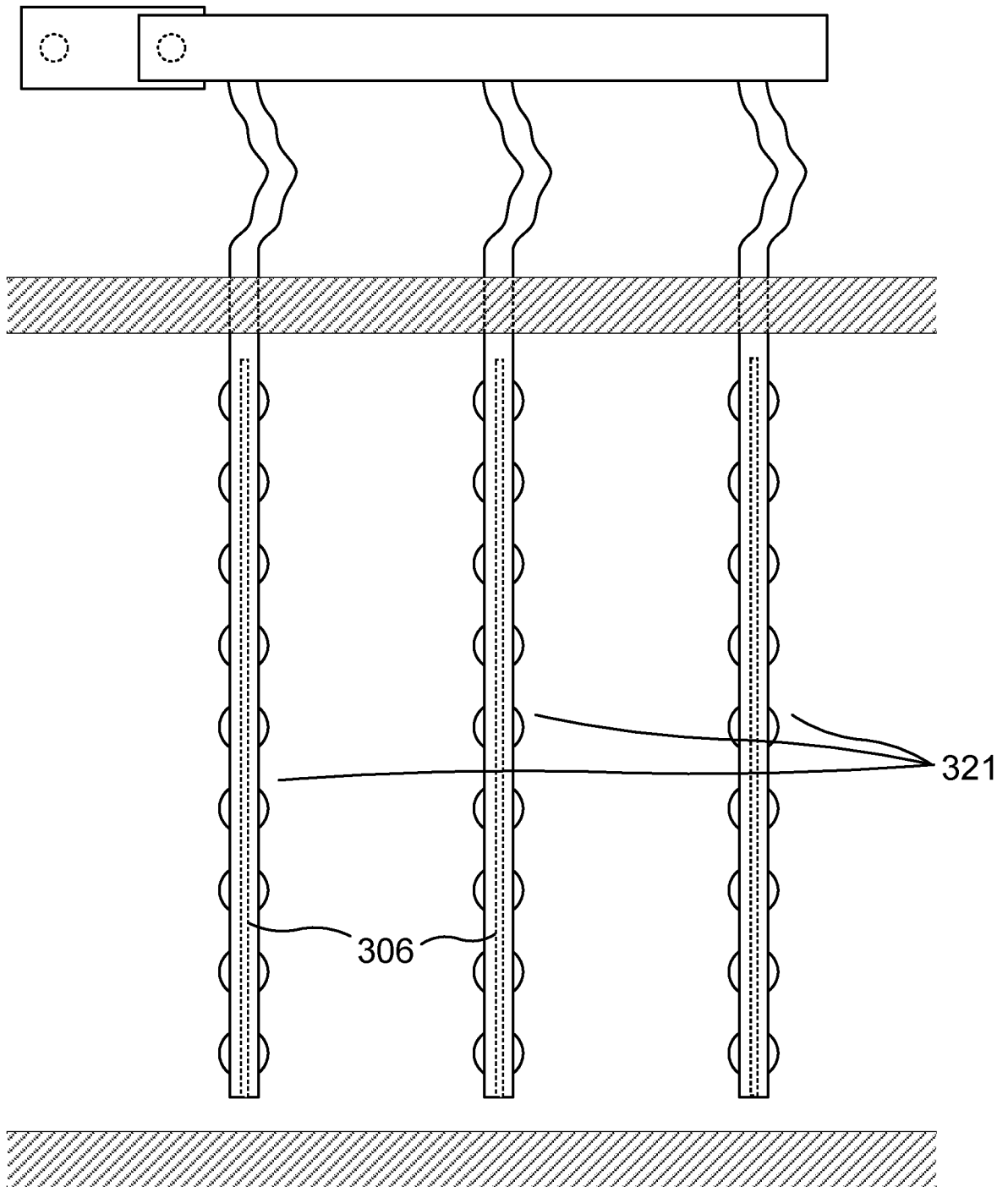

304  
⊙

## INTERNATIONAL SEARCH REPORT

International application No.  
PCT/SE2013/050842

## A. CLASSIFICATION OF SUBJECT MATTER

IPC: see extra sheet

According to International Patent Classification (IPC) or to both national classification and IPC

## B. FIELDS SEARCHED

Minimum documentation searched (classification system followed by classification symbols)

IPC: B01D, B03C

Documentation searched other than minimum documentation to the extent that such documents are included in the fields searched

SE, DK, FI, NO classes as above

Electronic data base consulted during the international search (name of data base and, where practicable, search terms used)

EPO-Internal, PAJ, WPI data

## C. DOCUMENTS CONSIDERED TO BE RELEVANT

Category*	Citation of document, with indication, where appropriate, of the relevant passages	Relevant to claim No.
X	SE 218681 C (AB BAHCO, STOCKHOLM), 13 February 1968 (1968-02-13); whole document	1, 3-5, 7-15
Y	--	2, 6
Y	DE 2829210 A1 (METALLGESELLSCHAFT AG), 17 January 1980 (1980-01-17); figures 1,2; claims 1, 3, 5, 6, 8, 9, 11; page 3, first paragraph - page 8, last paragraph	2, 6
A	US 4844718 A (SCHMIDT HERMANN ET AL), 4 July 1989 (1989-07-04); abstract; figures 1-3	1-15
	-- -----	

 Further documents are listed in the continuation of Box C. See patent family annex.

\* Special categories of cited documents:

"A" document defining the general state of the art which is not considered to be of particular relevance

"E" earlier application or patent but published on or after the international filing date

"L" document which may throw doubts on priority claim(s) or which is cited to establish the publication date of another citation or other special reason (as specified)

"O" document referring to an oral disclosure, use, exhibition or other means

"P" document published prior to the international filing date but later than the priority date claimed

"T" later document published after the international filing date or priority date and not in conflict with the application but cited to understand the principle or theory underlying the invention

"X" document of particular relevance; the claimed invention cannot be considered novel or cannot be considered to involve an inventive step when the document is taken alone

"Y" document of particular relevance; the claimed invention cannot be considered to involve an inventive step when the document is combined with one or more other such documents, such combination being obvious to a person skilled in the art

"&amp;" document member of the same patent family

Date of the actual completion of the international search

28-10-2013

Date of mailing of the international search report

29-10-2013

Name and mailing address of the ISA/SE

Patent- och registreringsverket  
Box 5055  
S-102 42 STOCKHOLM  
Facsimile No. + 46 8 666 02 86

Authorized officer

Barbara Silén

Telephone No. + 46 8 782 25 00

**Continuation of:** second sheet

**International Patent Classification (IPC)**

***B03C 3/76*** (2006.01)

***B01D 46/12*** (2006.01)

***B03C 3/80*** (2006.01)

***B03C 3/88*** (2006.01)

**INTERNATIONAL SEARCH REPORT**

Information on patent family members

International application No.

PCT/SE2013/050842

SE	218681 C	13/02/1968	NONE		
DE	2829210 A1	17/01/1980	NONE		
US	4844718 A	04/07/1989	AU	1860888 A	05/01/1989
			AU	597207 B2	24/05/1990
			BR	8803113 A	24/01/1989
			CA	1287707 C	20/08/1991
			DE	3722193 C1	09/06/1988
			EP	0300515 A3	14/02/1990
			IN	165248 A1	09/09/1989
			JP	1030663 A	01/02/1989
			JP	S6430663 A	01/02/1989
			ZA	8804734 A	28/03/1990