



US00D749490S

(12) **United States Design Patent**  
**Klick**

(10) **Patent No.:** **US D749,490 S**

(45) **Date of Patent:** **\*\* Feb. 16, 2016**

(54) **AIRCRAFT FUSELAGE**

(71) Applicant: **Ritewing RC, LLC**, Mesa, AZ (US)

(72) Inventor: **Christopher K. Klick**, Mesa, AZ (US)

(73) Assignee: **RITEWING RC, LLC**, Mesa, AZ (US)

(\*\*) Term: **14 Years**

(21) Appl. No.: **29/490,110**

(22) Filed: **May 6, 2014**

(51) **LOC (10) Cl.** ..... **12-07**

(52) **U.S. Cl.**

USPC ..... **D12/319**; D21/447

(58) **Field of Classification Search**

USPC ..... D12/319, 322, 323, 326, 327, 328, 329,  
D12/330, 339, 341, 342, 343, 344, 345;  
D21/436, 438, 439, 440, 441, 446, 447,  
D21/448, 449, 450, 453

CPC ..... B64C 39/00; B64C 30/00; B64C 29/00

See application file for complete search history.

(56) **References Cited**

U.S. PATENT DOCUMENTS

4,033,070 A \* 7/1977 Strongin ..... A63H 27/00  
446/68  
D306,997 S \* 4/1990 Andrews ..... D12/319

(Continued)

*Primary Examiner* — Robert M Spear

*Assistant Examiner* — Marissa J Cash

(74) *Attorney, Agent, or Firm* — Trenner Law Firm, LLC;  
Mark D. Trenner

(57) **CLAIM**

The ornamental design for an aircraft fuselage, substantially as shown and described.

**DESCRIPTION**

FIG. 1 is a top perspective view of a first aircraft fuselage, wherein wings are shown as these may be attached to the aircraft fuselage;

FIG. 2 is a bottom perspective view of the aircraft fuselage, wherein wings are shown as these may be attached to the aircraft fuselage;

FIG. 3 is a top perspective view of the aircraft fuselage;

FIG. 4 is a top view of the design corresponding to FIG. 1;

FIG. 5 is a bottom view of the design corresponding to FIG. 2;

FIG. 6 is a front view of the design corresponding to FIG. 1;

FIG. 7 is a back view of the design corresponding to FIG. 1;

FIG. 8 is a right side view of the design corresponding to FIG. 1;

FIG. 9 is a left side view of the design corresponding to FIG. 1;

FIG. 10 is a top perspective view of a second aircraft fuselage, wherein wings are shown as these may be attached to the aircraft fuselage;

FIG. 11 is a bottom perspective view of the second aircraft fuselage, wherein wings are shown as these may be attached to the aircraft fuselage;

FIG. 12 is a top perspective view of the second aircraft fuselage;

FIG. 13 is a top view of the design corresponding to FIG. 10;

FIG. 14 is a bottom view of the design corresponding to FIG. 11;

FIG. 15 is a front view of the design corresponding to FIG. 10;

FIG. 16 is a back view of the design corresponding to FIG. 10;

FIG. 17 is a right side view of the design corresponding to FIG. 10; and,

FIG. 18 is a left side view of the design corresponding to FIG. 10

and wherein the wings are shown in broken lines and do not form a part of the design.

**1 Claim, 14 Drawing Sheets**

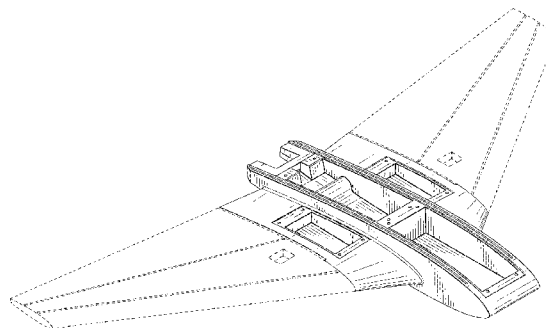
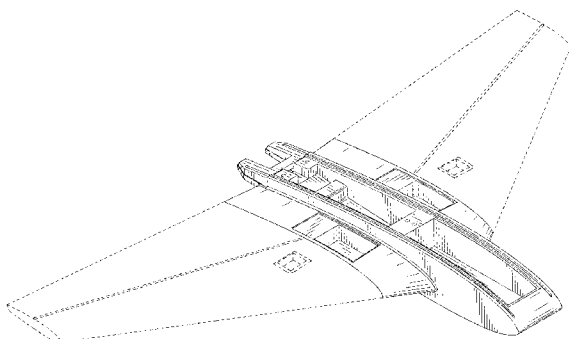



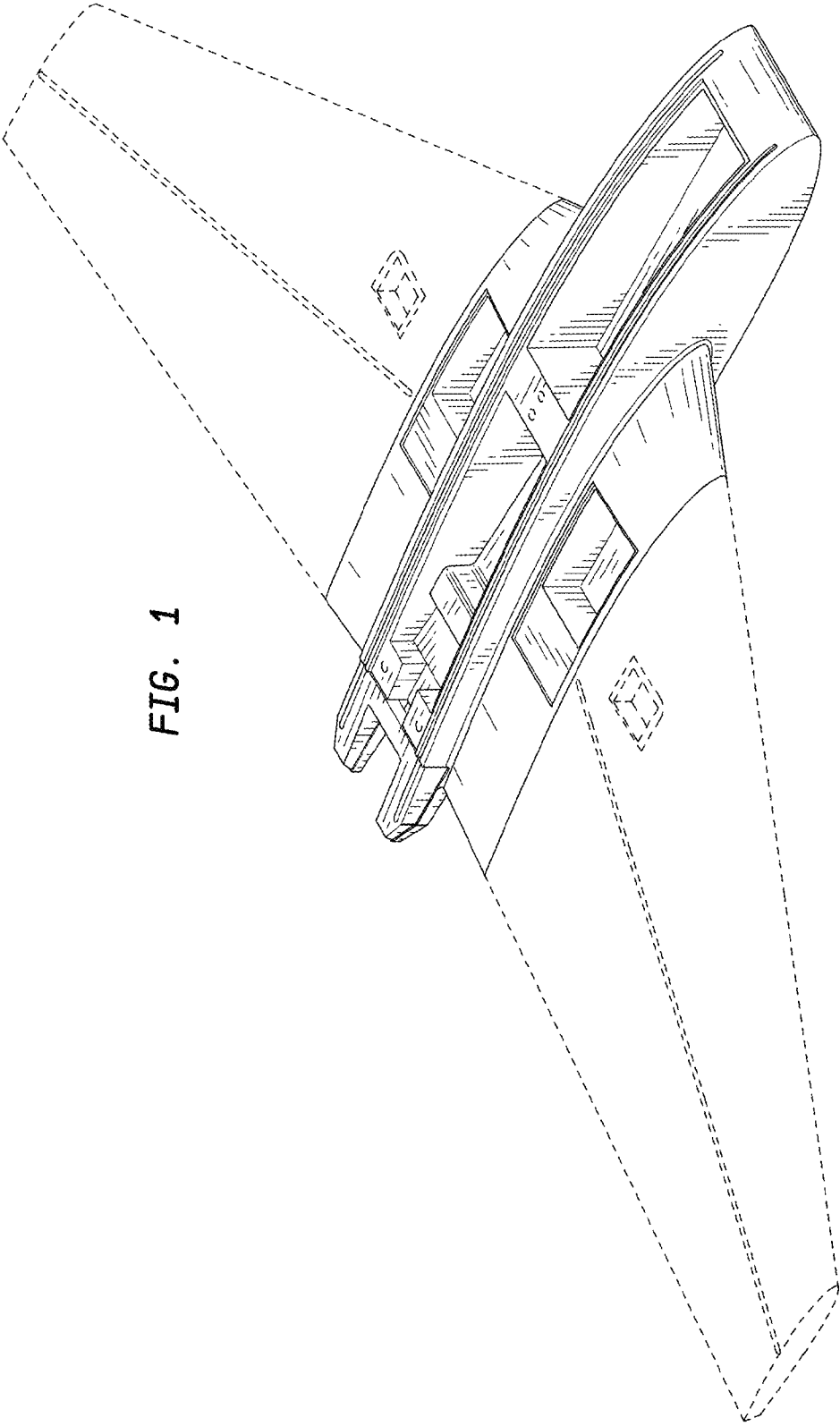

FIG. 1

FIG. 2

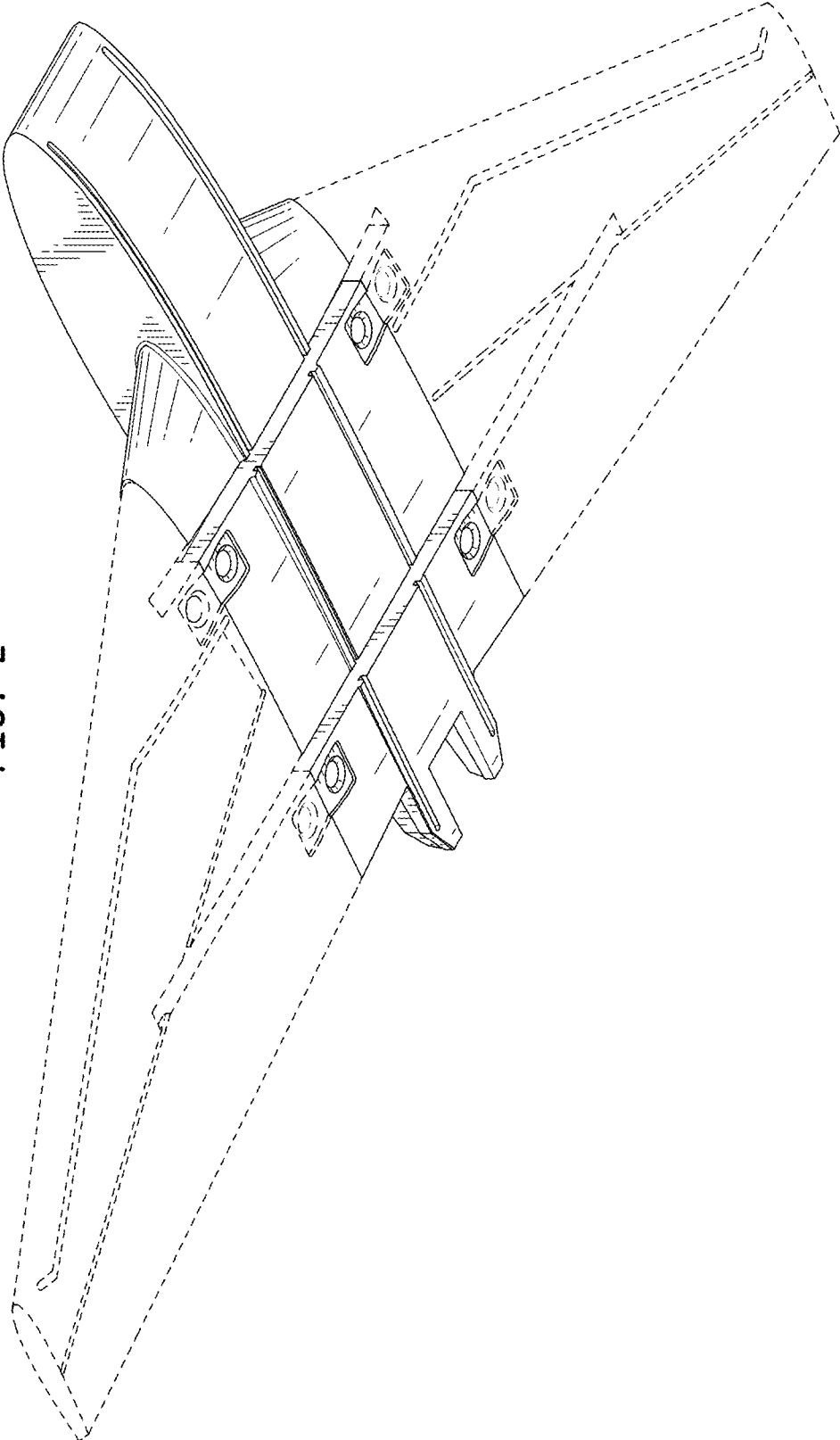

FIG. 3

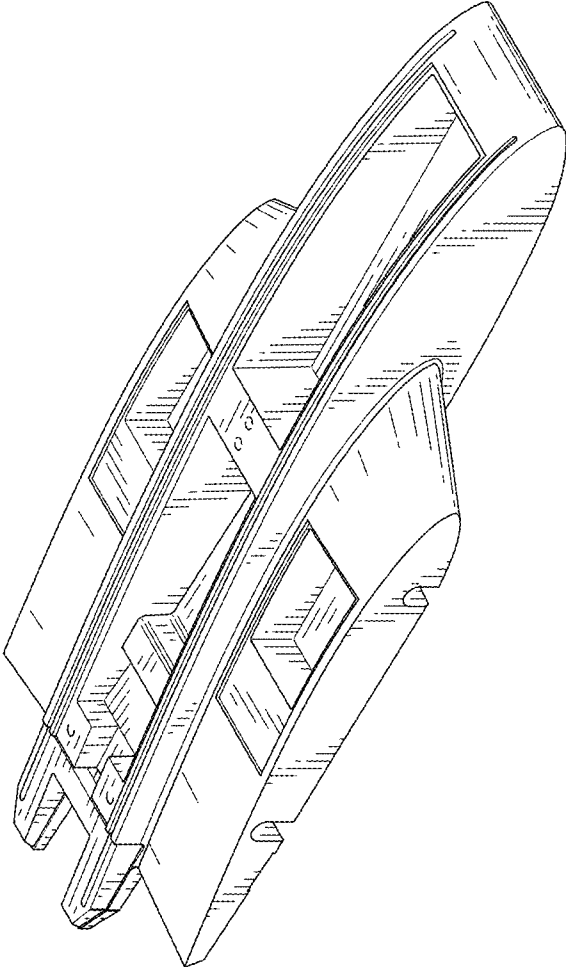

FIG. 4

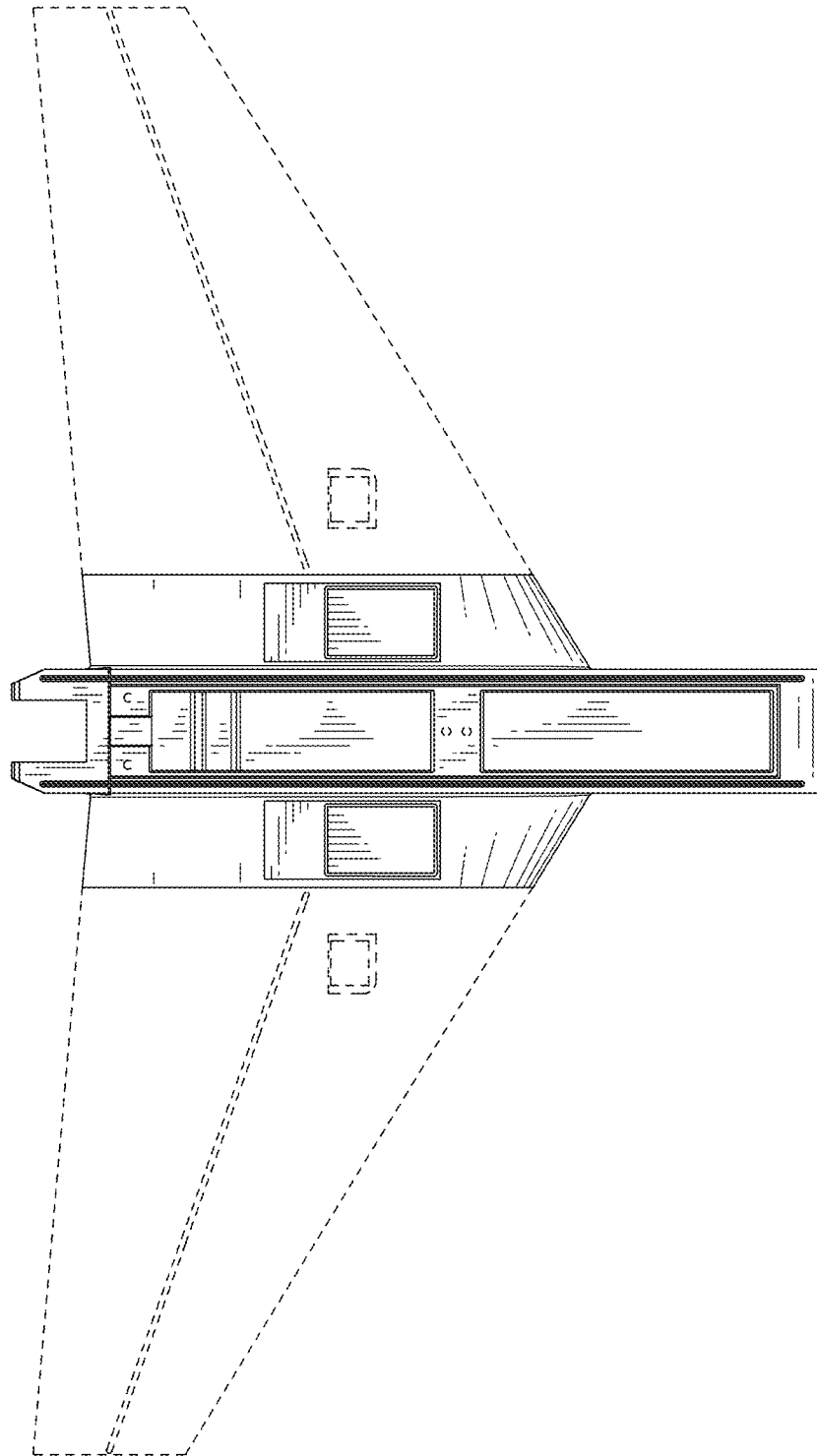

FIG. 5

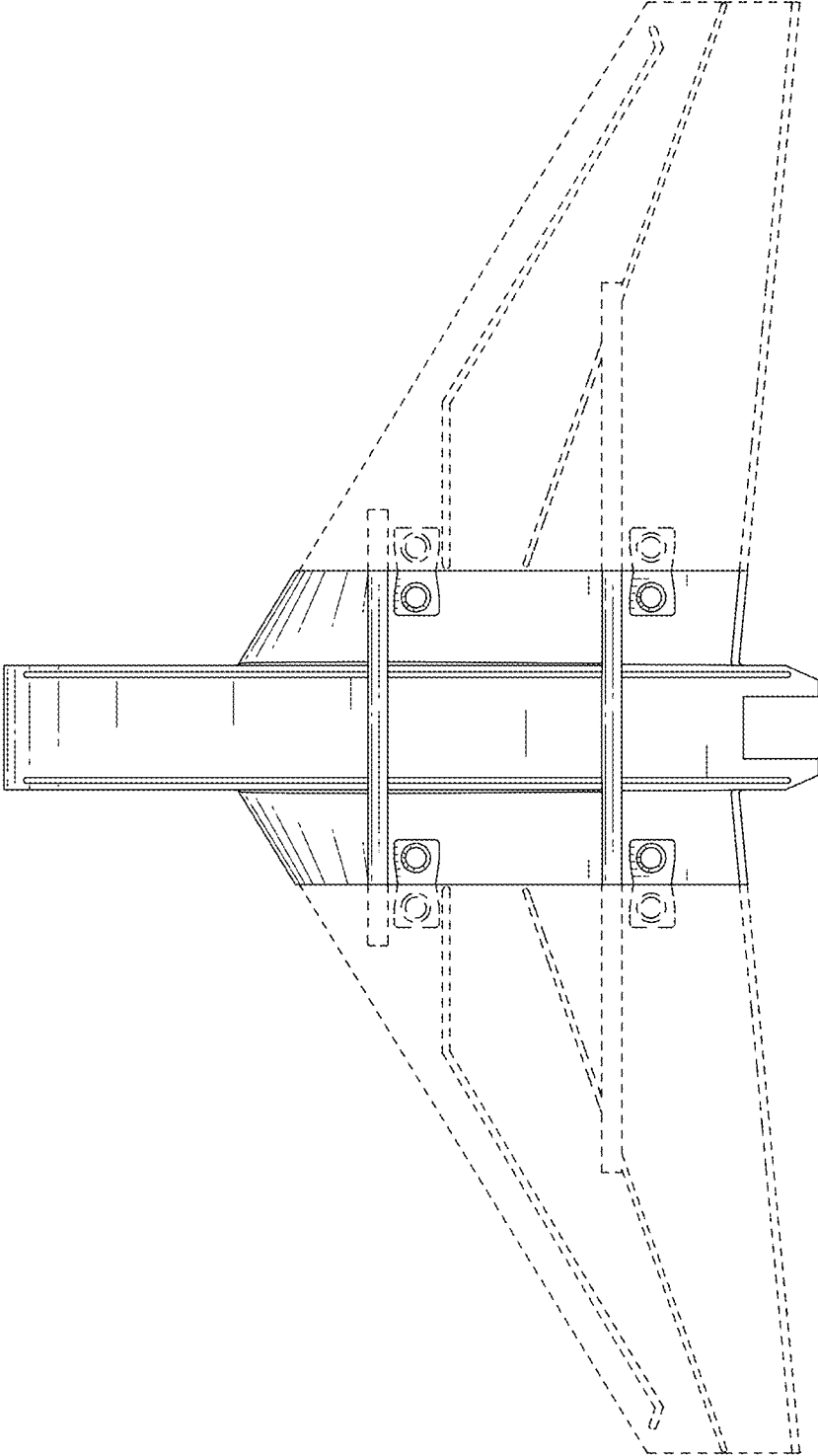

FIG. 6

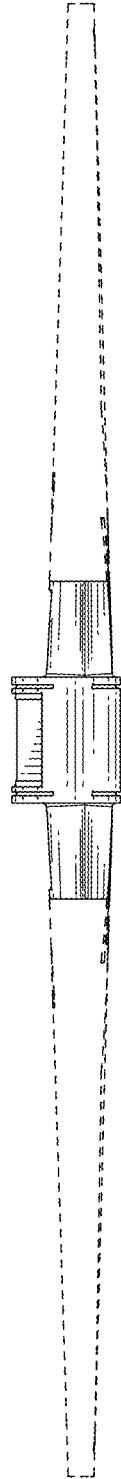

FIG. 7

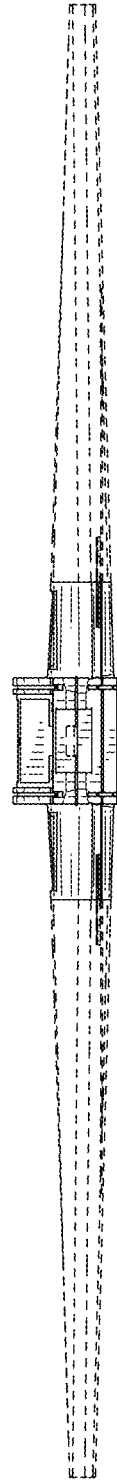

FIG. 8

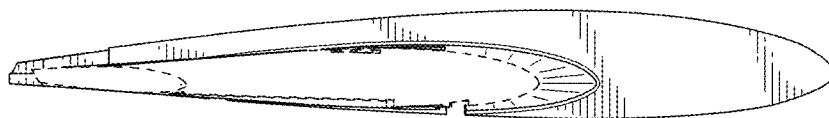
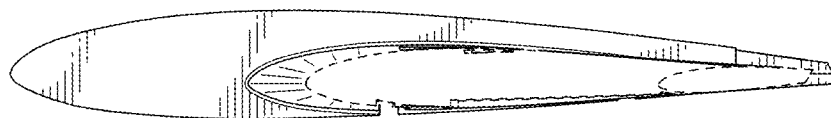

FIG. 9



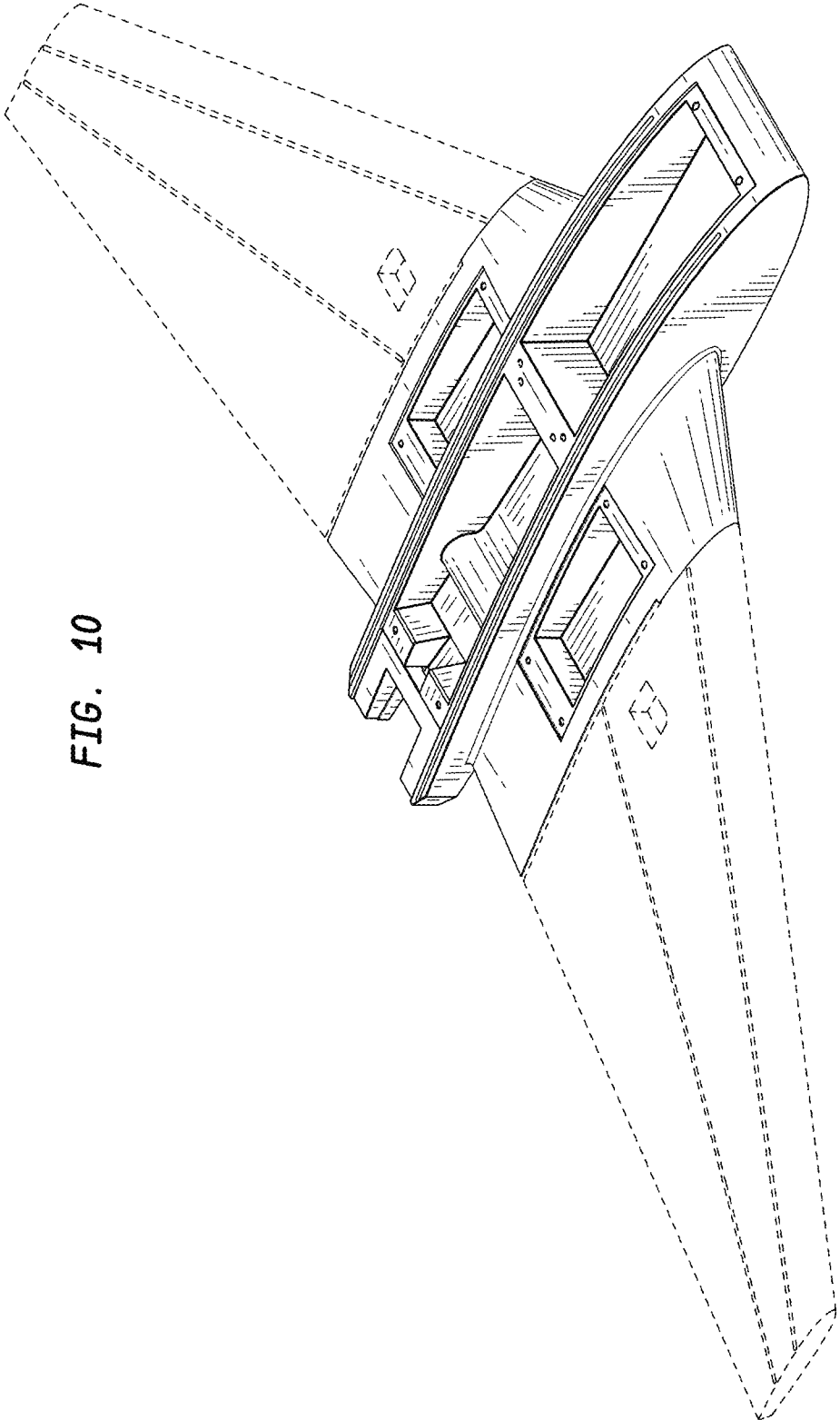

FIG. 10

FIG. 11

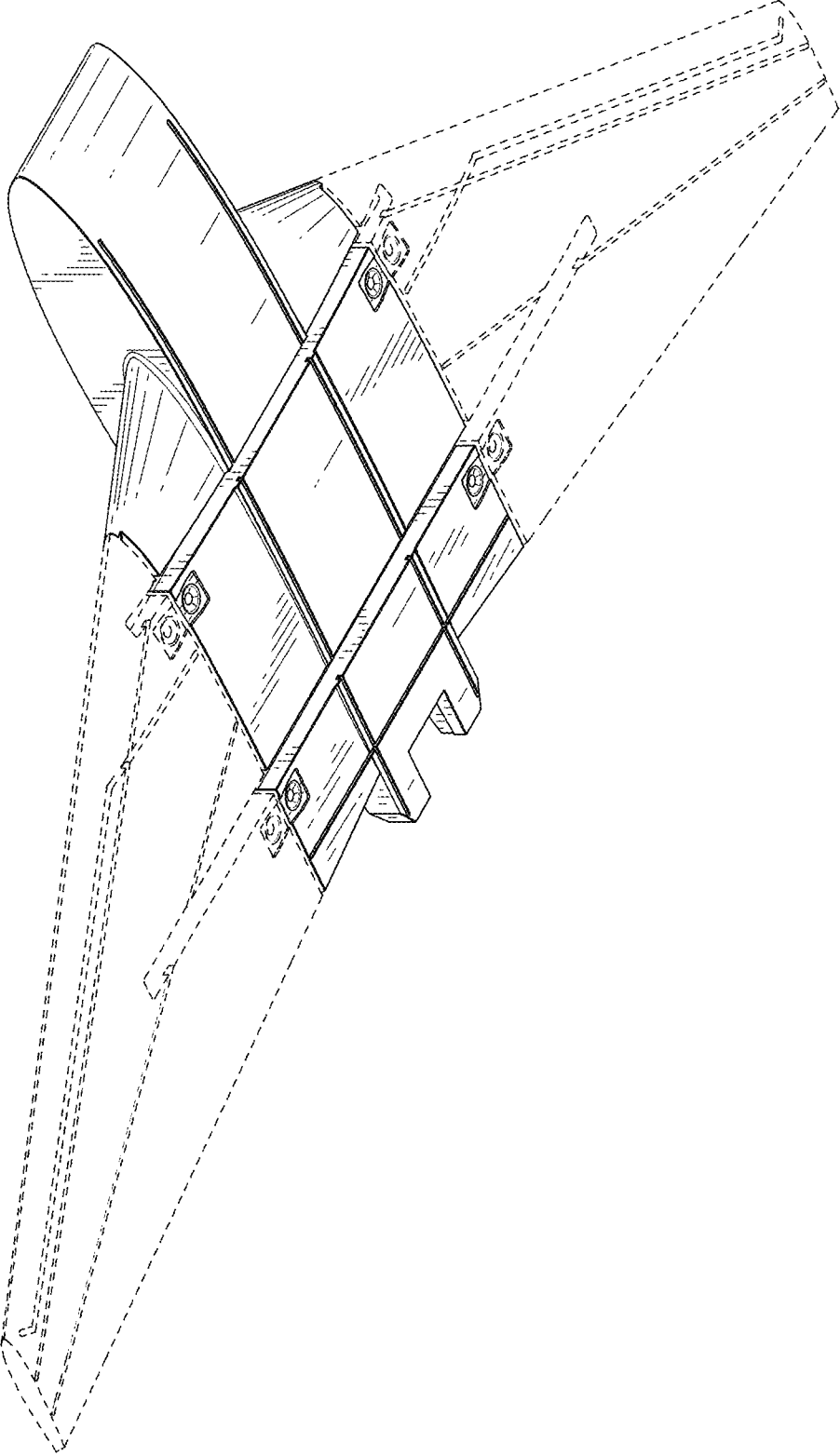

FIG. 12

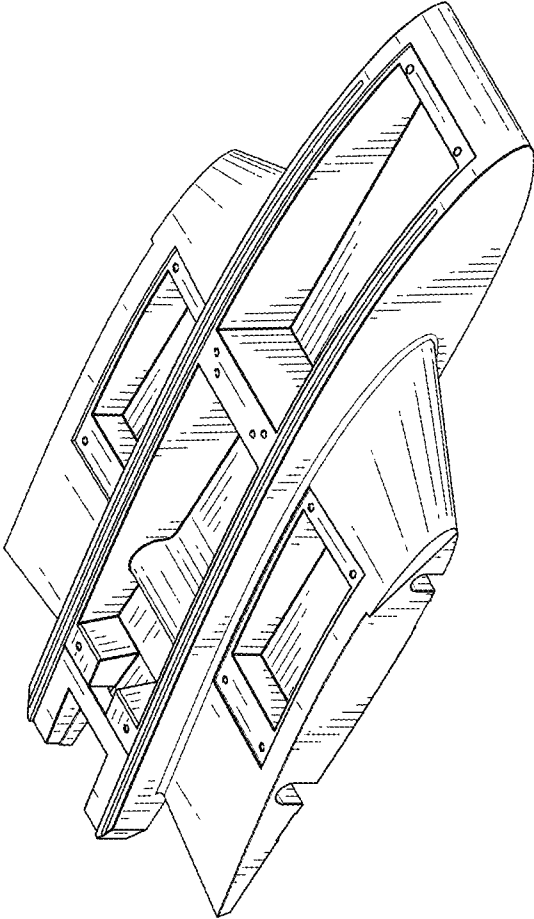

FIG. 13

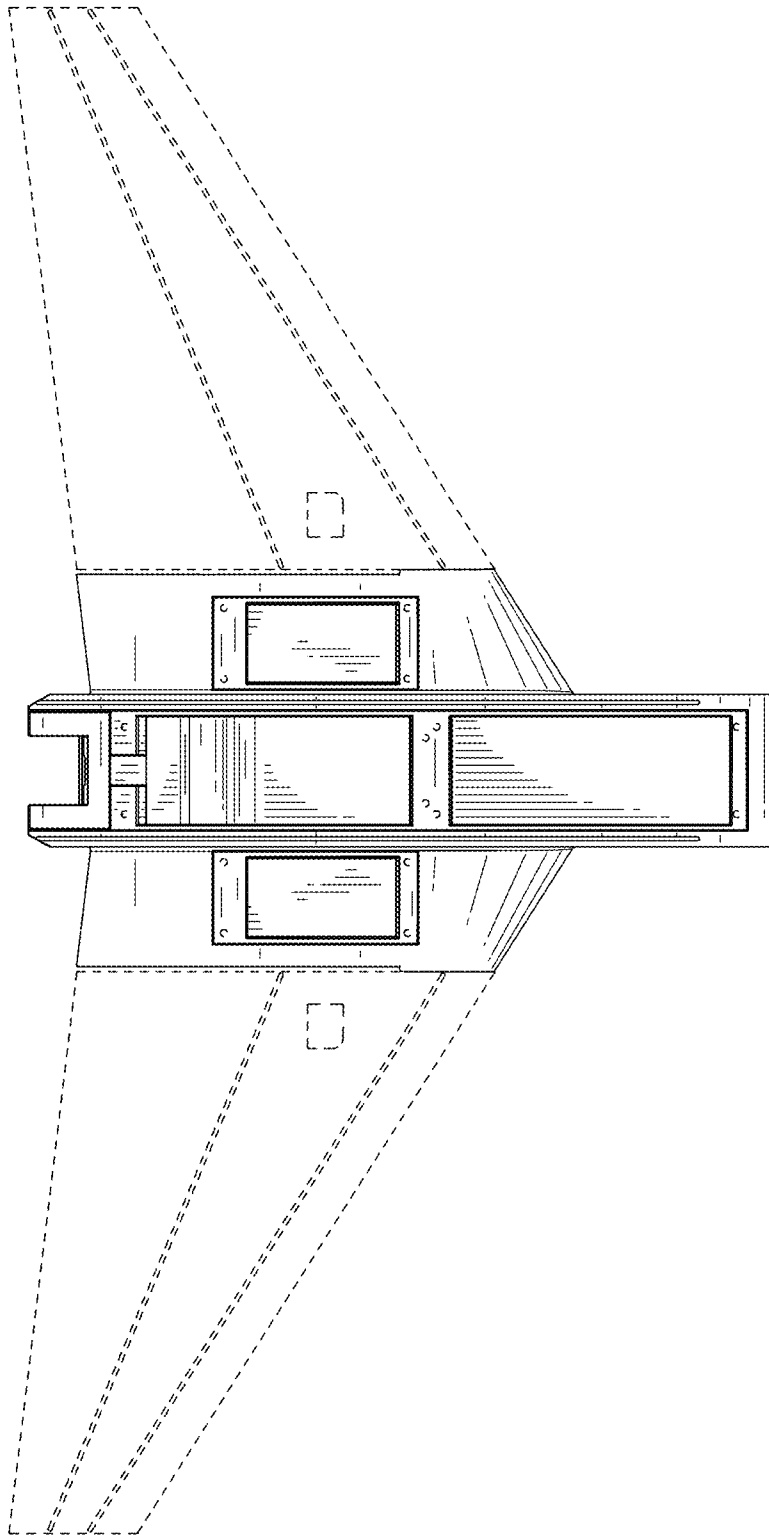

FIG. 14

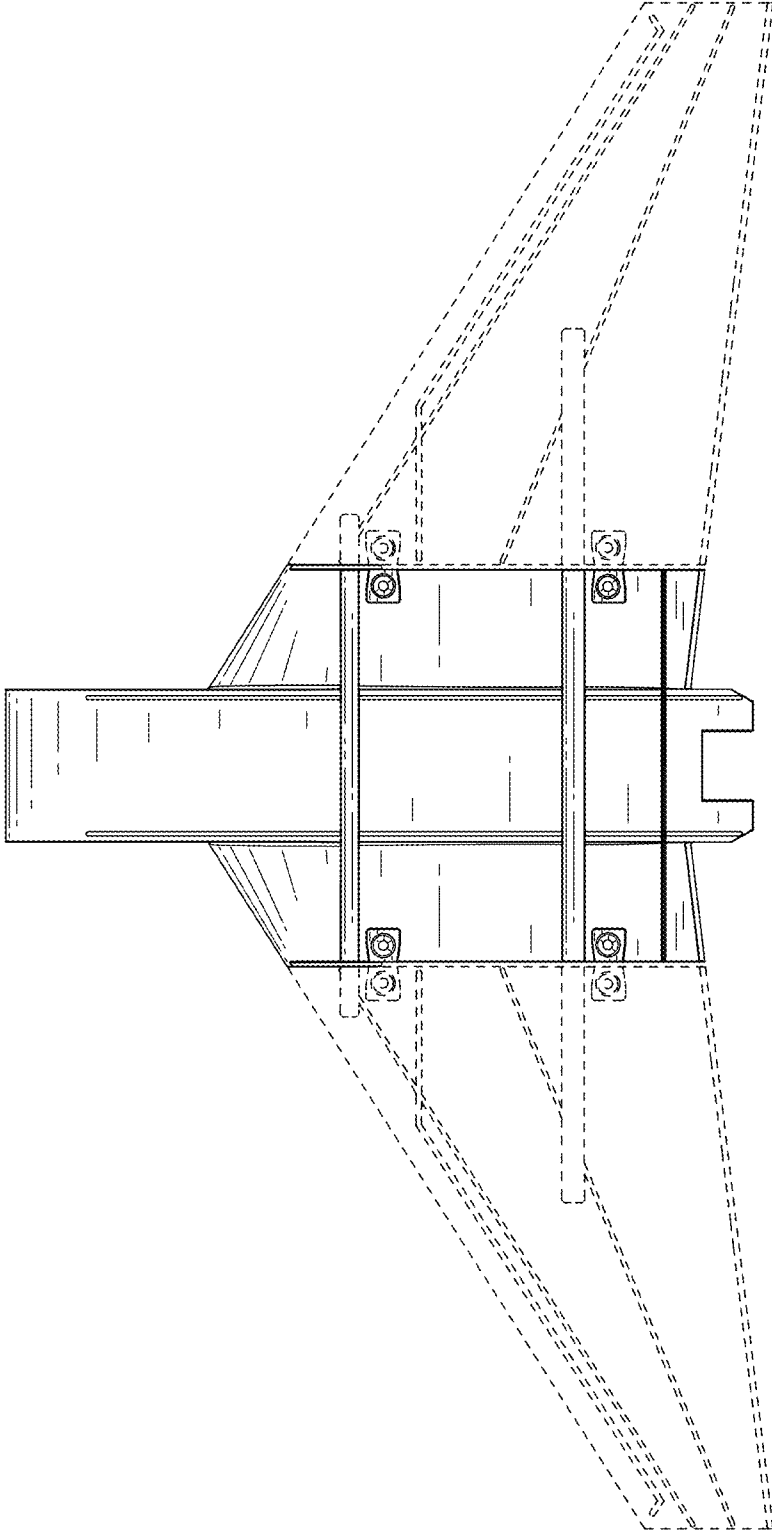

FIG. 15

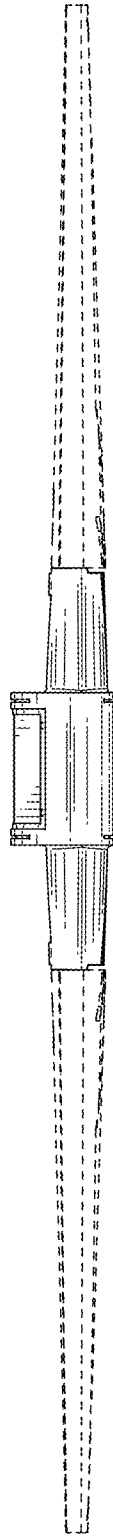

FIG. 16

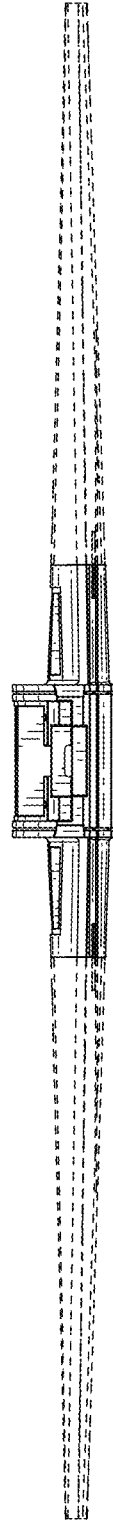

FIG. 17



FIG. 18

