

(19) (KR)  
(12) (Y1)

(51) 。 Int. Cl.<sup>7</sup> (45) 2004 10 08  
B29C 49/26 (11) 20-0364183  
B29C 49/36 (24) 2004 09 30

(21) 20-2004-0019604  
(22) 2004 07 09

(73) 543-9 201

1-66 가-101

(72) 543-9 201

1-66 가-101

(74)

:

(54) 가

中空成形法) , 가 (blow molding,  
가 , 가  
가 , (100) (212) ( (200) ; (100) (300)  
210) , (222) : (220) , (100) (300) ; (100) (300)  
(110) , (222) : (220) , (100) (212) ( (200) ; (100) (300)  
, (100) (120) (122) (300) ; (100) (300)  
(210) (210) (212) (120) (122) (122) (220) (200) (220)  
(310) , (100) (100) (122) (220) (310) (320)  
(100) (120) (122) (220) (320)

, , , , , , , , ,

1 ;

2 ;

3 ;

4 ;

5 6 1 ;

7 6 , ;

8 9 2 ;

10

< >

1: 2:

3: 100:

110: 120:

122: 200:

210: 212:

220: 222:

300: 310:

320: 330:

340: 342:

344: 346:

中空成形法)

(blow molding,

가

가

가

(injection molding)

(10)

(12)

가

가

가

(12)

(14)가

(1)

(2)

(10)

(3)

(10)

(12)

(14)가

12)

가

(

가

가

가

가

(blow molding)

(20)

2

(22)

가

(20)

(24)

가

(1)

(2)

(3)

(2)

가

(26)

(1)

(2

6)

(24)

(25)

(27)

(20)

(22)

(blow molding)

(26)

(26)

(injection molding)

(22)

(1)

(2)

가

가

가

가

(26)

가

가

가

가

가

3 (100) 4

110) 3 (100) (100) (122)  
 )가 (110) (120) (120)

(100) (110)가 (120)  
 가 (100) (1) (2)

(100) (110) (120) 가

(100) (100) (110) (120) 가  
 (120) (122)

(120) (122) (110)가

(100) (110) 3 4  
 가

가 4 (100) (1) (110) (2) (120) (122)가  
 (20) (20) (1) 2 (3) (26)

5 9 (100)

5 9 (100) (A)(B)  
 (200) (100) (110) (120) (A)(B) (122)  
 (300)

(100) (200) 가 (210) (2)

22) (100) (220) (210)

(300) (100) (120) (122) (100) (120)  
 (200) (210) (120) (220) (310) (120) (100) (120)  
 (122) (220) (310) (310) (120) (100) (122)

(320)

(220) (222) (200) (212)  
 (100)

(320) 5 6 (310) (220)  
 (220) (330)

8 9 (220) (342) (342)  
 (344)가 (346) (340) (340) (340)  
 (346)

10 (220) (310) (220) (220)  
 (222)

(A)(B) (120) (122)가  
 (100)

5 6 (A) (100)

5 (200) (210) (210) (212) (100)  
 (220) (222) (120) (120)  
 (220) (310) (110) (100) (122)가 (120)

6 (220) (310) (100)  
 (210) (320) (330) (120)  
 (220) (310) (122) (100)  
 (122) (310) 가 (310)  
 (210) (110)가

7 (210) (110) (120)  
 (310) (110)가 (210)  
 (100) (210)  
 (120) (122)가 (220) (310)

(210) (310) (120) (122) 가  
 (100)

8 9 (B) 5 6 (A) (100)  
 (200) (100) (100) (120) (1  
 22) (220) (310) (320)

8 (200) (210) (100) 9 (210)  
 (340) (342) (346) (220) (346)  
 (344) (310) (310) (120) (122  
 )가 (122) (100) (110)가 (21  
 0)

0) , (A)(B) , (100) (100) (11  
(122) (120) (122)가 (320)  
(220) (310) 가 .

, 10 (220) (310) 가 (310)  
(310) 가 , 가 가 (220)

, 가 , 가 가 가

, 가 가 가 가

(57)

1.

(100) :  
(120) (100) (120) (110) , (110) (122)가  
가

2.

1 (100) :  
(220) , (100) (212) (210) , (222)  
(300) ; (200) ; (100) (110)

(300) , (100) (120) (122)  
(200) (210) (212) (122)  
(220) (310) , (100) (220)  
(310) (100) (120) 가 (122) (220)  
(320)

3.

2 (320) , (310) (220) ( )  
330) 가

4.

2 (320) (220) (342) , (342)  
(344)가 (346) (340)

5.

2 , (310) (220) 가 , 가

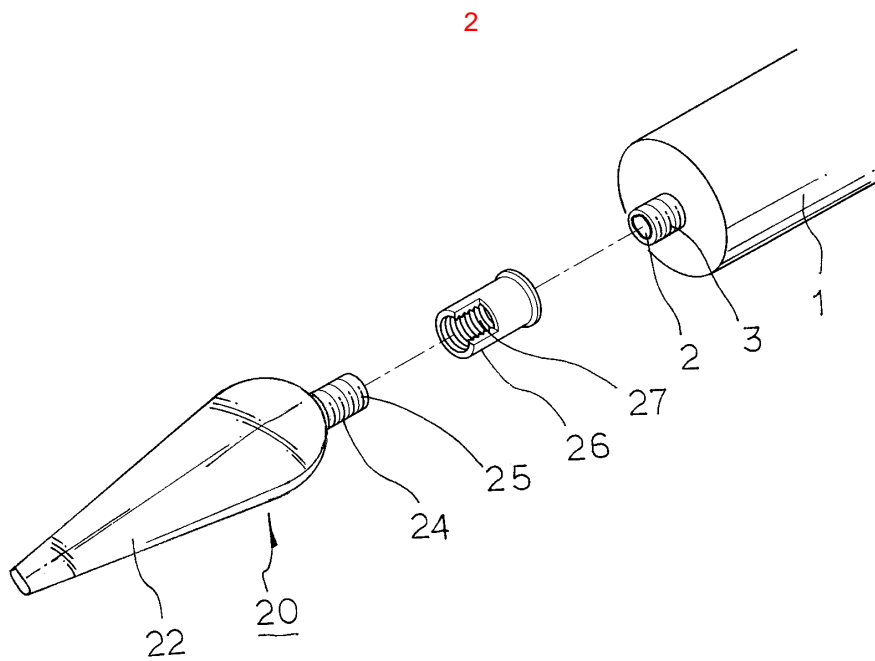
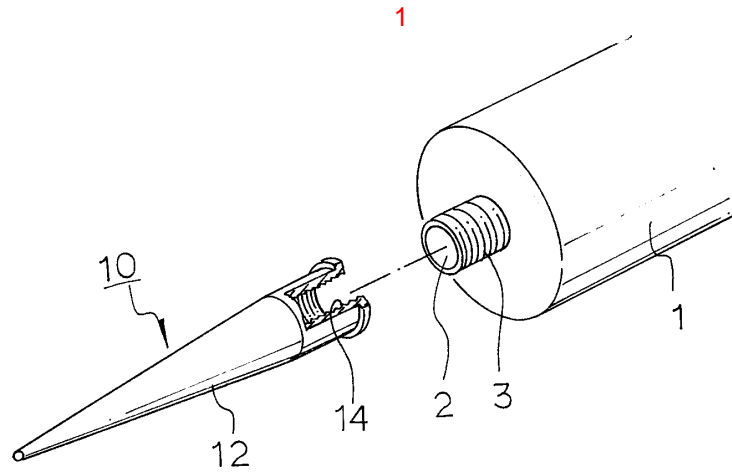

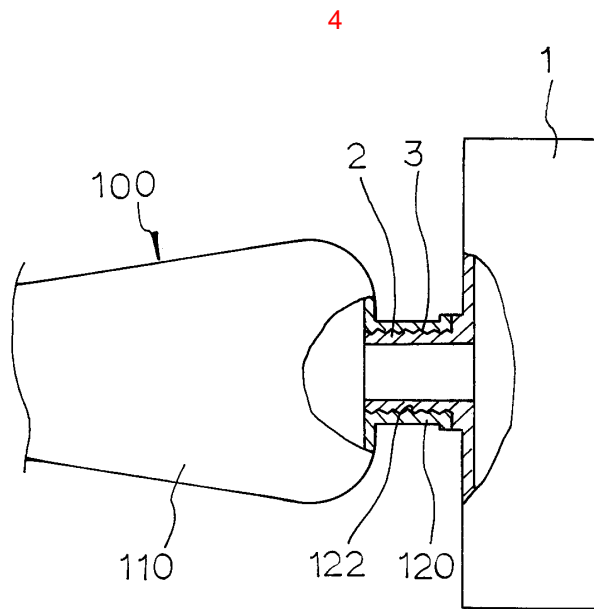
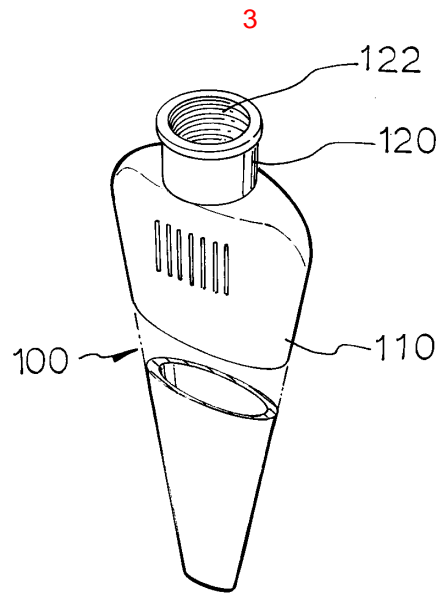

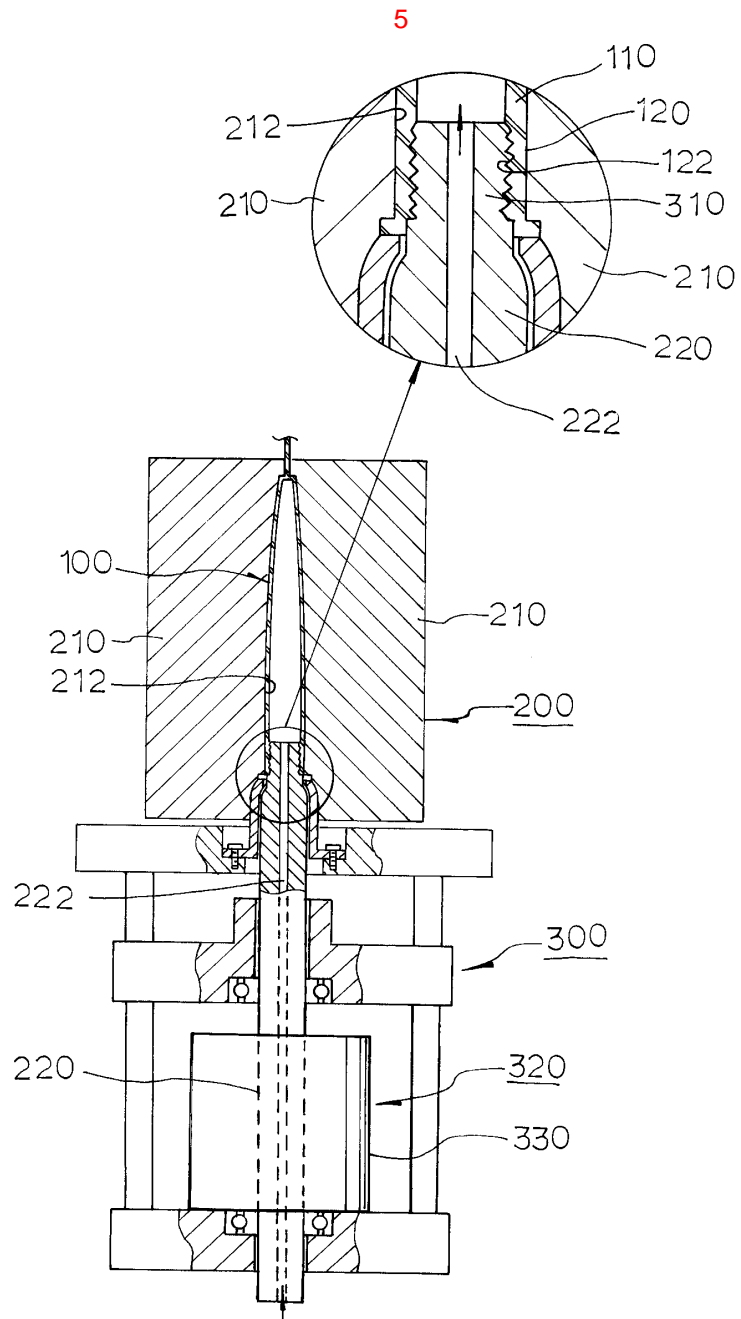

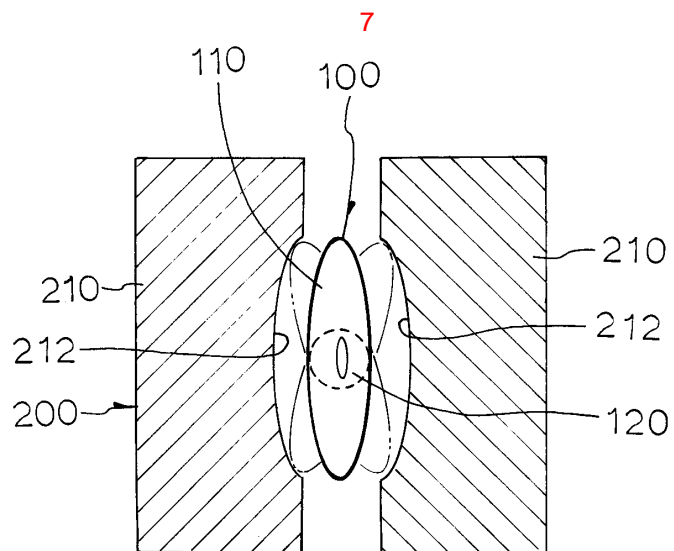
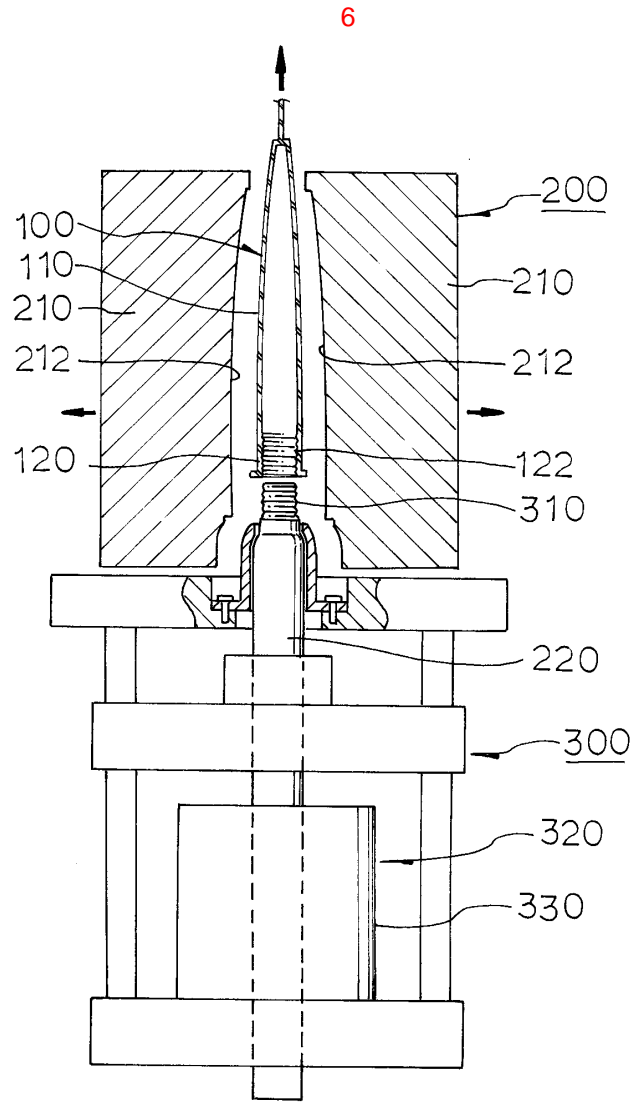

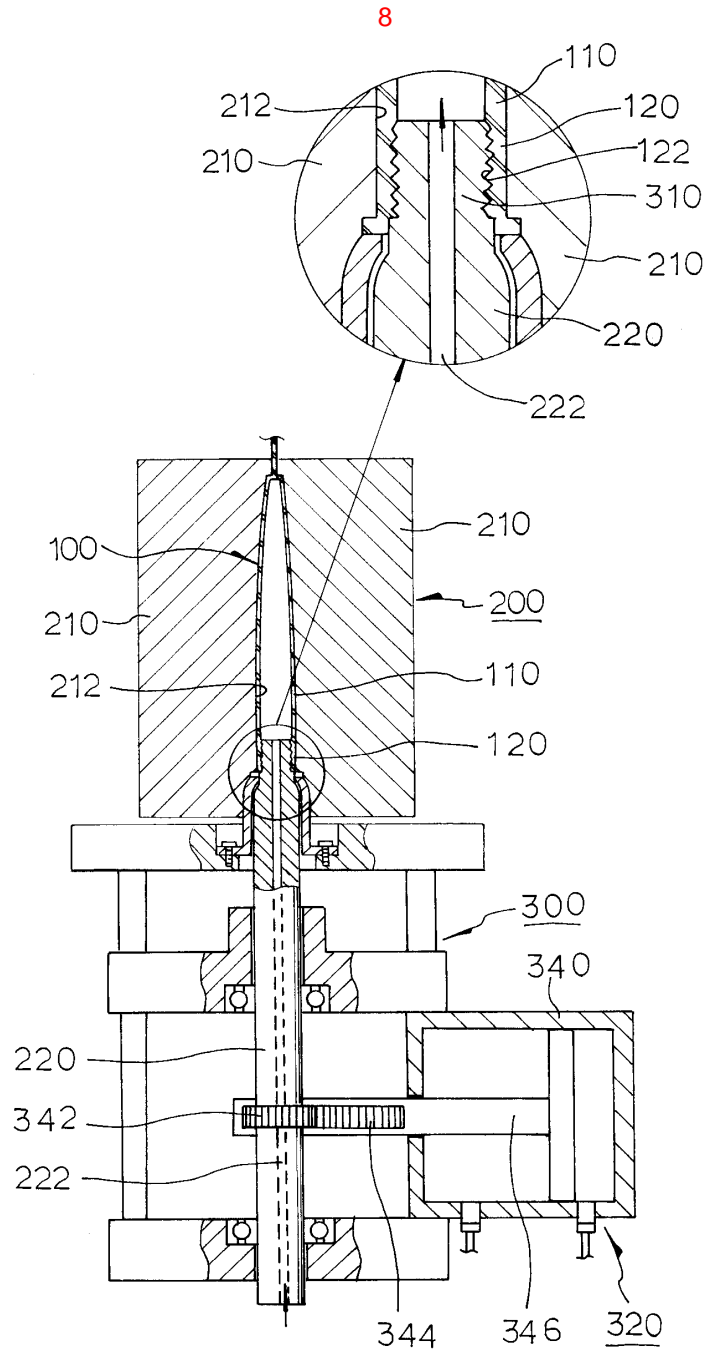

9

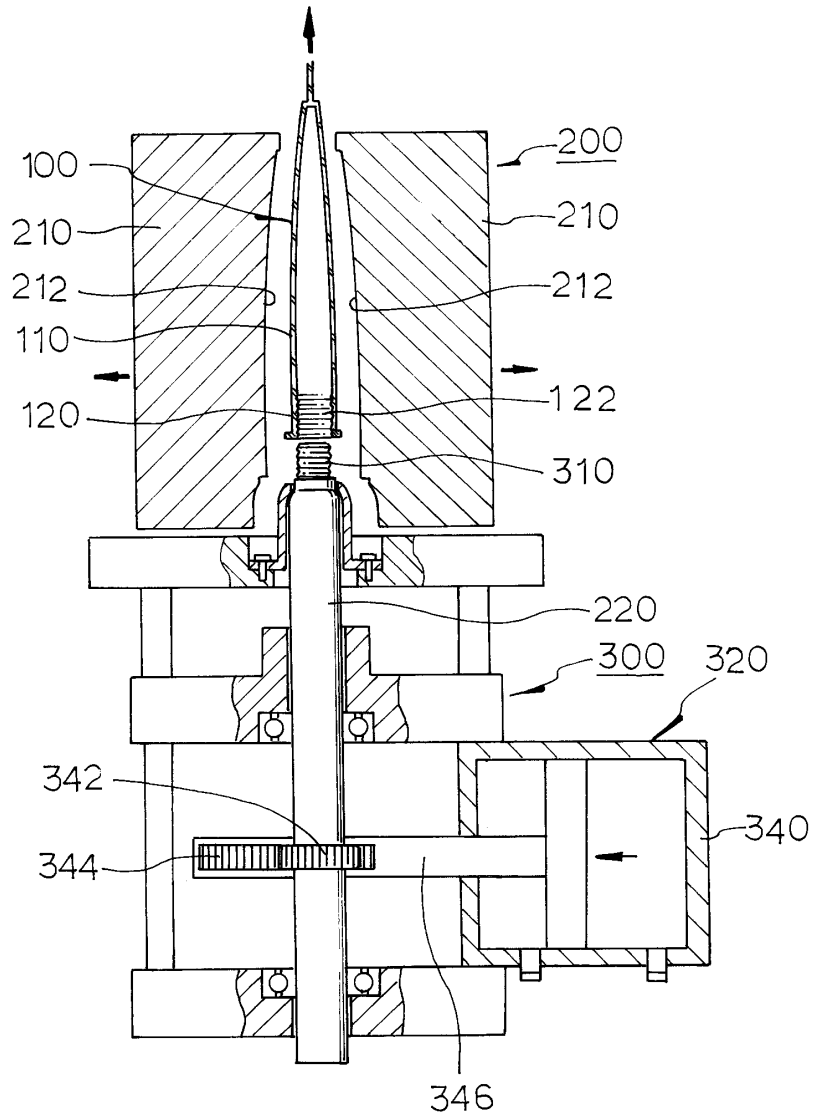

10

