



## INTERNATIONAL APPLICATION PUBLISHED UNDER THE PATENT COOPERATION TREATY (PCT)

(51) International Patent Classification <sup>6</sup> : <b>A61F 2/06</b>	<b>A1</b>	(11) International Publication Number: <b>WO 97/17912</b> (43) International Publication Date: 22 May 1997 (22.05.97)
<p>(21) International Application Number: PCT/US96/17379</p> <p>(22) International Filing Date: 29 October 1996 (29.10.96)</p> <p>(30) Priority Data: 08/558,034 13 November 1995 (13.11.95) US</p> <p>(71) Applicant: CORVITA CORPORATION [US/US]; 8210 N.W. 27th Street, Miami, FL 33122 (US).</p> <p>(74) Agent: MEHLER, Raymond, M.; Lockwood, Alex, FitzGibbon &amp; Cummings, Suite 1700, Three First National Plaza, Chicago, IL 60602 (US).</p>	<p>(81) Designated States: AU, CA, JP, European patent (AT, BE, CH, DE, DK, ES, FI, FR, GB, GR, IE, IT, LU, MC, NL, PT, SE).</p> <p><b>Published</b> <i>With international search report. Before the expiration of the time limit for amending the claims and to be republished in the event of the receipt of amendments.</i></p>	

(54) Title: EXPANDABLE SUPPORTIVE BIFURCATED ENDOLUMINAL GRAFTS

## (57) Abstract

An endoluminal graft which is both expandable and supportive is provided in a form suitable for use in a bifurcated body vessel location. The graft expands between a first diameter and a second, larger diameter. The support component is an expandable stent endoprosthesis. A cover, a liner, or both a cover and a liner are applied to the endoprosthesis in the form of a stretchable wall material that is porous, elastomeric and biocompatible in order to allow normal cellular invasion upon implantation, without stenosis, when the expandable and supportive graft is at its second diameter. The supportive endoluminal graft is preferably provided as a plurality of components that are deployed separately at the bifurcated body vessel location.

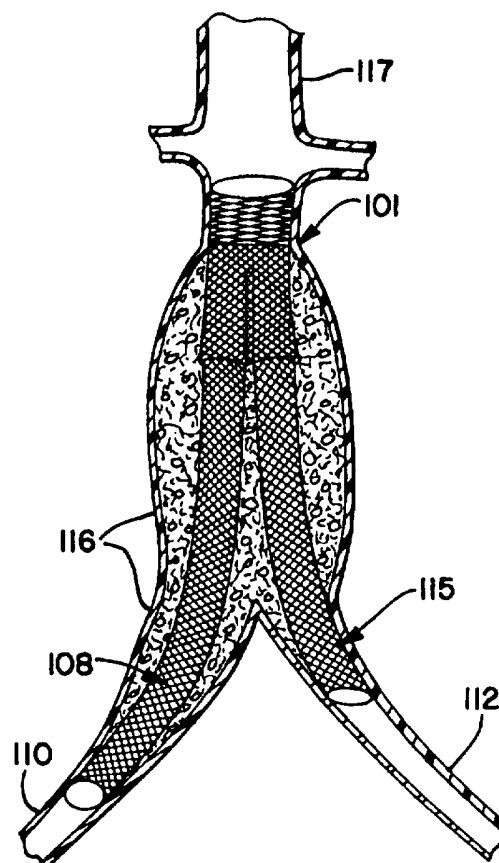

**FOR THE PURPOSES OF INFORMATION ONLY**

Codes used to identify States party to the PCT on the front pages of pamphlets publishing international applications under the PCT.

<b>AM</b>	Armenia	<b>GB</b>	United Kingdom	<b>MW</b>	Malawi
<b>AT</b>	Austria	<b>GE</b>	Georgia	<b>MX</b>	Mexico
<b>AU</b>	Australia	<b>GN</b>	Guinea	<b>NE</b>	Niger
<b>BB</b>	Barbados	<b>GR</b>	Greece	<b>NL</b>	Netherlands
<b>BE</b>	Belgium	<b>HU</b>	Hungary	<b>NO</b>	Norway
<b>BF</b>	Burkina Faso	<b>IE</b>	Ireland	<b>NZ</b>	New Zealand
<b>BG</b>	Bulgaria	<b>IT</b>	Italy	<b>PL</b>	Poland
<b>BJ</b>	Benin	<b>JP</b>	Japan	<b>PT</b>	Portugal
<b>BR</b>	Brazil	<b>KE</b>	Kenya	<b>RO</b>	Romania
<b>BY</b>	Belarus	<b>KG</b>	Kyrgystan	<b>RU</b>	Russian Federation
<b>CA</b>	Canada	<b>KP</b>	Democratic People's Republic of Korea	<b>SD</b>	Sudan
<b>CF</b>	Central African Republic	<b>KR</b>	Republic of Korea	<b>SE</b>	Sweden
<b>CG</b>	Congo	<b>KZ</b>	Kazakhstan	<b>SG</b>	Singapore
<b>CH</b>	Switzerland	<b>LI</b>	Liechtenstein	<b>SI</b>	Slovenia
<b>CI</b>	Côte d'Ivoire	<b>LK</b>	Sri Lanka	<b>SK</b>	Slovakia
<b>CM</b>	Cameroon	<b>LR</b>	Liberia	<b>SN</b>	Senegal
<b>CN</b>	China	<b>LT</b>	Lithuania	<b>SZ</b>	Swaziland
<b>CS</b>	Czechoslovakia	<b>LU</b>	Luxembourg	<b>TD</b>	Chad
<b>CZ</b>	Czech Republic	<b>LV</b>	Latvia	<b>TG</b>	Togo
<b>DE</b>	Germany	<b>MC</b>	Monaco	<b>TJ</b>	Tajikistan
<b>DK</b>	Denmark	<b>MD</b>	Republic of Moldova	<b>TT</b>	Trinidad and Tobago
<b>EE</b>	Estonia	<b>MG</b>	Madagascar	<b>UA</b>	Ukraine
<b>ES</b>	Spain	<b>ML</b>	Mali	<b>UG</b>	Uganda
<b>FI</b>	Finland	<b>MN</b>	Mongolia	<b>US</b>	United States of America
<b>FR</b>	France	<b>MR</b>	Mauritania	<b>UZ</b>	Uzbekistan
<b>GA</b>	Gabon			<b>VN</b>	Viet Nam

## EXPANDABLE SUPPORTIVE BIFURCATED ENDOLUMINAL GRAFTS

DescriptionCross Reference to Related Application

This is a continuation-in-part of application Serial No. 140,245, filed October 21, 1993.

Background and Description of the Invention

This invention generally relates to supportive endoluminal grafts which have the ability to be delivered transluminally and expanded in place to provide a graft that is endoluminally positioned and placed, with the aid of an appropriate inserter or catheter, and that remains so placed in order to both repair a vessel defect and provide lasting support at the location of the graft. In its broadest sense, the graft combines into a single structure both an expandable luminal prosthesis tubular support component and an elastomeric graft component secured thereto. The expandable supportive luminal graft takes on a bifurcated structure made up of components that are designed to be positioned in a bifurcated manner with respect to each other during deployment or repair and support of vessel locations at or near branching sites. Preferably, the graft component is stretchable or elastomeric and does not substantially inhibit expansion of the tubular support component while simultaneously exhibiting porosity which facilitates normal cellular growth or invasion thereinto of tissue from the body passageway after implantation.

Elastomeric vascular grafts are known to be made by various methods. Included are methods which incorporate electrostatic spinning technology such as that described by Annis et al. in "An Elastomeric Vascular

Prosthesis", *Trans. Am. Soc. Artif. Intern. Organs*, Vol. XXIV, pages 209-214 (1978) and in U.S. Patent No.

4,323,525. Other approaches include elution of particulate material from tubular sheeting, such as by incorporating salts, sugars, proteins, water-soluble hydrogels, such as polyvinyl pyrrolidone, polyvinyl alcohol, and the like, within polymers and then eluting the particulate materials by immersion in water or other solvent, thereby forming pores within the polymer.

Exemplary in this regard is U.S. Patent No. 4,459,252, incorporated by reference hereinto. Another approach involves the forming of pores in polymers by phase inversion techniques wherein a solventized polymer is immersed in another solvent and the polymer coagulates while the polymer solvent is removed. Also known are spinning techniques such as those described in U.S. Patent No. 4,475,972. By that approach, a polymer such as a polyurethane in solution is extruded as fibers from a spinnerette onto a rotating mandrel. The spinnerette system reciprocates along a path which is generally parallel to the longitudinal axis of the mandrel and at a controlled pitch angle. The result is a non-woven structure where each fiber layer is bound to the underlying fiber layer.

Also known are stent devices, which are placed or implanted within a blood vessel or other body cavity or vessel for treating occlusions, stenoses, aneurysms, disease, damage or the like within the vessel. These stents are implanted within the vascular system or other system or body vessel to reinforce collapsing, partially occluded, weakened, diseased, damaged or abnormally dilated sections of the vessel. At times, stents are used to treat disease at or near a branch, bifurcation and/or anastomosis. This runs the risk of compromising the degree of patency of the primary vessel and/or its branches or bifurcation, which may occur as a result of several problems such as displacing diseased tissue,

vessel spasm, dissection with or without intimal flaps, thrombosis and embolism.

One common procedure for implanting a stent is to first open the region of the vessel with a balloon catheter and then place the stent in a position that bridges the diseased portion of the vessel. Various constructions and designs of stents are known. U.S. Patent No. 4,140,126 describes a technique for positioning an elongated cylindrical stent at a region of an aneurysm to avoid catastrophic failure of the blood vessel wall, the stent being a cylinder that expands to an implanted configuration after insertion with the aid of a catheter. Other such devices are illustrated in U.S. Patents No. 4,787,899 and No. 5,104,399. U.S. Patents No. 4,503,569 and No. 4,512,338 show spring stents which expand to an implanted configuration with a change in temperature. It is implanted in a coiled configuration and then heated in place to cause the material of the spring to expand. Spring-into-place stents are shown in U.S. Patent No. 4,580,568. U.S. Patent No. 4,733,665 shows a number of stent configurations for implantation with the aid of a balloon catheter. U.S. Patent No. 5,019,090 shows a generally cylindrical stent formed from a wire that is bent into a series of tight turns and then spirally wound about a cylindrical mandrel to form the stent. When radially outwardly directed forces are applied to the stent, such as by the balloon of an angioplasty catheter, the sharp bends open up and the stent diameter enlarges. U.S. Patent No. 4,994,071 describes a bifurcating stent having a plurality of wire loops that are interconnected by an elongated wire backbone and/or by wire connections and half hitches.

Stents themselves often do not encourage normal cellular invasion and can lead to undisciplined development of cells in the stent mesh, with rapid development of cellular hyperplasia. Grafts alone do not provide adequate support in certain instances. Copending

application of Jean-Pierre Dereume, Serial No. 112,774, entitled "Luminal Graft Endoprostheses and Manufacture Thereof" describes grafts that have the ability to carry out dilatation and/or support functions. An expandable tubular support component and an elastomeric graft component are combined into a single device wherein the graft material is secured to either or both of the internal and external surfaces of the expandable support component. The graft material is produced by a spinning technique such as that described in U.S. Patent No. 4,475,972. Also, luminal endoprostheses with an expandable coating on the surface of external walls of radially expandable tubular supports are proposed in U.S. Patents No. 4,739,762 and No. 4,776,337. In these two patents, the coating is made from thin elastic polyurethane, Teflon film or a film of an inert biocompatible material. A. Balko et al., "Transfemoral Placement of Intraluminal Polyurethane Prosthesis for Abdominal Aortic Aneurysm", *Journal of Surgical Research*, 40, 305-309, 1986, and U.S. Patents No. 5,019,090 and No. 5,092,877 mention the possibility to coat stent materials with porous or textured surfaces for cellular ingrowth or with non-thrombogenic agents and/or drugs. The various patents and publications referred to hereinabove are incorporated hereinto by reference.

By the present invention, grafts which are expandable and supportive are provided that expand from a first diameter to a second diameter which is greater than the first. When it is at its first diameter, the expandable supportive graft is of a size and shape suitable for insertion into the desired body passageway. The material of the graft is substantially inert and has a generally cylindrical cover and/or lining generally over the outside and/or inside surface of the expandable supportive component. Preferably, the cover and/or lining is especially advantageous because it is elastomeric and porous to encourage desirable growth of tissue thereinto

in order to assist in non-rejecting securement into place and avoidance of stenosis development. The porous, elastomeric liner and/or cover material is elastomeric enough to allow for expansion by up to about 2 to 4 times or more of its unexpanded diameter. Components of the bifurcated expandable supportive luminal graft are deployable separately such that each component is properly positioned with respect to the other into the desired bifurcated arrangement.

It is a general object of the present invention to provide an improved endoluminal graft that is expandable in place and, once expanded, is self-supporting.

Another object of this invention is to provide biocompatible grafts having a plurality of components that are separately expandable *in vivo* and that are supportive once so expanded.

Another object of the present invention is to provide an improved expandable reinforced graft that is delivered by way of introducers, balloon catheters or similar devices, and which facilitates good tissue ingrowth.

Another object of this invention is to provide an improved endoluminal graft which fully covers diseased or damaged areas for carrying out luminal repairs or treatments, such as repair of aneurysms.

Another object of the present invention is to provide an improved endoluminal graft wherein the endoprosthesis is substantially enclosed within biocompatible elastomeric material which is presented to the surrounding tissue and blood or other body fluid.

Another object of this invention is to provide an expandable, supportive graft that can be tailored to meet a variety of needs, including a single graft designed to address more than a single objective.

Another object of the present invention is to provide a self-expanding reinforced graft device that is

delivered in its elongated and compressed state from within a tubular member and deployed by moving same out of the tubular member, which device is especially suitable for component deployment.

5 Another object of this invention is to provide a bifurcated trunk component that is deployed in a collapsed state and expanded *in vivo* to a branched device for use in treatment and/or repair at branched vessel locations.

10 A further object of the present invention is to provide a component bifurcated endoluminal graft having a bifurcated trunk and at least one cylindrical branch which are expanded separately after endoluminal delivery and such that they form a bifurcated graft once positioned with respect to each other and expanded, typically  
15 separately.

These and other objects, features and advantages of this invention will be clearly understood through a consideration of the following detailed description.

#### 20 Brief Description of the Drawings

The invention will be further elucidated in the following description with reference to the drawings, in which:

25 Fig. 1 is a perspective view, partially cut away, of an expandable supportive endoluminal graft construction in accordance with the invention;

Fig. 2 is a cross-sectional view along the line 2-2 of Fig. 1;

30 Fig. 3 is a perspective view, partially cut away, of another embodiment of the expandable supportive endoluminal graft construction;

Fig. 4 is a cross-sectional view along the line 4-4 of Fig. 3;

35 Fig. 5 is a perspective view, partially cut away, of a further embodiment of the expandable luminal graft construction;



Fig. 6 is a cross-sectional view along the line 6-6 of Fig. 5;

Fig. 7 is a perspective view, partially cut away, of a bifurcated expandable supportive endoluminal graft construction;

Fig. 8 is a cross-sectional view along the line 8-8 of Fig. 7;

Fig. 9 is a somewhat schematic view illustrating an early step in the implantation of a device such as shown in Fig. 7;

Figs. 10, 11 and 12 are generally schematic views along the lines of Fig. 9 showing expansion of the main body and the branches of this bifurcated device;

Fig. 13 shows this bifurcated supportive graft after completion of the expansion procedure;

Fig. 14 illustrates another embodiment of a bifurcated expandable supportive endoluminal graft construction;

Figs. 15, 16 and 17 illustrate implantation and assembly of the graft of Fig. 14;

Figs. 18, 19, 20, 21, 22, 23, 24 and 25 illustrate a component bifurcated graft and various stages of its separate, component deployment within the body vessel to repair an aneurysm, Figs. 18 and 19 showing deployment of a preferred bifurcated trunk component, Figs. 20 through 24 showing separate deployment of two branch components, and Fig. 25 showing aneurysm healing and contracting after a time following implantation;

Fig. 26 is a perspective view of a preferred bifurcation trunk component which has a single lumen area opening into a double lumen area;

Fig. 27 is a bottom end view of the bifurcation trunk component of Fig. 26; and

Fig. 28 is a perspective view of another embodiment of a bifurcation trunk component, the single lumen area of which has a section of enhanced hoop strength.

Description of the Particular Embodiments

An embodiment of expandable supportive luminal graft construction is generally illustrated in Fig. 1 at 21. This embodiment includes a braided tubular support component having generally helically wound rigid but flexible strand or wire elements, some of which have the same direction of winding but are axially displaced from one another, and others of which cross these windings and are also axially displaced with respect to each other.

The actual structure can be generally braided as illustrated in Wallsten U.S. Patent No. 4,655,771, incorporated by reference hereinto, or as found in self-expanding braided flat wire Wallstent® devices. Both a cover 23 and a liner 24 are illustrated in Figs. 1 and 2. Either cover 23 or liner 24 can be omitted if there is no desire to substantially encapsulate the tubular support component 22.

With more particular reference to the illustrated cover 23 and liner 24, when included, they may be formed by an electrostatic spinning process in this illustrative embodiment. Details regarding electrostatic spinning techniques in general are found in Bornat U.S. Patent No. 4,323,525 and in Bornat European patent publication No. 9,941, as well as in the Annis et al. article discussed hereinabove, the disclosures of which are incorporated by reference hereinto. With further reference to the application of this technology to the expandable supportable luminal grafts of the present invention, random pattern filaments are formed and electrostatically directed toward a charged mandrel in order to form a random pattern of electrostatically generally cross-linked filaments which take on the configuration of a mat having a cylindrical shape. The filament diameters are particularly fine, as is the pore size of the mat so constructed. A typical range of filament diameters is between about 0.5 micron and about 5 microns, and a typical pore size of the electrostatically

spun fiber is between about 3 microns and about 20 microns.

Liner 24 is formed directly on the rotating mandrel by this electrostatic spinning procedure. Thereafter, one of the tubular support components discussed herein, such as the generally braided tubular support 22, is placed over the liner 24 still on the mandrel. In the case of the tubular support 22 in a form that is not spring loaded, this includes longitudinally extending the tubular support 22, such as by pulling one or both of its ends, which thereby decreases its diameter so that it fits snugly over the liner 24. When the generally braided tubular support 22 is of a spring-into-place type, a hold-down member (such as shown in Figs. 18, 20 and 23) is used to prevent automatic radial expansion prior to deployment. When the expandable supportive graft 21 is to include a cover 23, the mandrel is again rotated, and the electrostatic spinning is again accomplished in order to form the cover 23 directly over the tubular support 22. This will also create some bonding between the thus formed cover 23 and the liner 24 at openings between the strands or wires of the woven tubular support 22 or the like. This bonding can be facilitated by uniformly compressing the outer fibers with a soft silicone roller or sponge such that the still tacky outer fibers bond to the inner fibers thereby encapsulating the tubular support within the graft.

Bonding may also be achieved in this or other embodiments by heat welding and/or by the use of adhesives such as hot melt adhesives, primers, coupling agents, silicone adhesives, and the like, and combinations of these. Examples include aliphatic polycarbonate urethane hot melts and silicone rubber adhesives.

It is important to note that each of the cover 23 and the liner 24, when either or both are present, is made of an elastomeric material which retains its compliant properties after construction of the expandable

supportive graft 21 is completed. In this regard, the graft itself is also elastomeric and compliant.

Accordingly, the graft 21 is delivered transluminally, such as by being pulled down onto the balloon of a

5 catheter and then percutaneously inserted and positioned to the location where the repair is needed. For a non-spring loaded graft, the balloon is then inflated to longitudinally contract and radially expand the graft 21 into engagement with the vessel walls. Because of the

10 compliance of the cover 23 and/or liner 24, and because of the hoop strength of the braided tubular support 22, the graft 21 will remain in place. In the illustrated embodiment, ends 25 of the tubular support are exposed and

are not covered by the cover 23. This allows the exposed end portions 25 to directly engage the vessel wall, if

15 desired in the particular application, in order to assist in anchoring the graft 21 in place. Liner 24 also can be sized so as to not cover the exposed ends 25, or it can extend to or beyond the edge of the ends 25 when it is

20 desired to avoid or minimize contact between the tubular support and the blood or other fluid flowing through the vessel being repaired or treated.

Alternatively, when a braided tubular support such as that illustrated in Figs. 1 and 2 is incorporated

25 into the graft according to the present invention in a non-spring-loaded form, transluminal delivery can be made by way of a catheter or tool having means for longitudinally compressing the endoprosthesis until it has

30 expanded radially to the desired implanted diameter. Such equipment typically includes a member that engages one end of the endoprosthesis and another member which engages the other end of the endoprosthesis. Manipulation of

proximally located controls then effects relative movement of the members toward each other in order to thereby

35 longitudinally compress the endoprosthesis. Delivery tools for spring-loaded grafts include a sleeve that maintains the graft at its compressed diameter until the

graft is positioned for deployment such as from the end of an insertion catheter to its auto-expanded state.

With reference to the embodiment illustrated in Figs. 3 and 4, an expandable supportive graft is illustrated at 31. The illustrated tubular support component 32 is constructed of sinusoidally configured wire helically wound into a tubular shape. General structures of these types are generally discussed in Pinchuk U.S. Patent No. 5,019,090, incorporated by reference hereinto. A cover 33 can be positioned over the tubular support 32 and/or a liner 34 can be positioned along its lumen. In this illustrated embodiment, the cover 33 and liner 34 are constructed of porous polymers, the pores thereof having been made by elution or extraction of salts and the like, such as described in MacGregor U.S. Patent No. 4,459,252, incorporated by reference hereinto. Generally speaking, the porosity is determined by the size of the elutable particles as discussed herein and by the concentration of those particles as a percent by volume of a pre-elution mixture thereof with the polymer of the cover or liner. When a graft 31 having both a cover 33 and a liner 34 is prepared, a mandrel or rod is dipped into a liquid polymer having elutable particles as discussed herein dispersed therewithin. After dipping, the polymer covered rod is contacted with, such as by dipping or spraying, a solvent, for the elutable particles, such as water, thereby forming the eluted porous liner 34. Thereafter, the tubular support 32 is positioned thereover and pressed down into the liner. Then, the rod and the assembly thereon are again dipped into the mixture of polymer and elutable particles, followed by setting and contact with solvent to remove the elutable particles in order to form the eluted porous cover 33. It is also possible to directly extrude the particle-containing polymer into a tubular shape.

Elutable particles which can be used in the making of the eluted porous cover 33 and liner 34 include

salts such as sodium chloride crystals, sodium carbonate, calcium fluoride, magnesium sulfate and other water-soluble materials that are readily dissolved by the utilization of water as an elution medium. Other  
5 particles that are soluble in organic solvents and the like can be substituted as desired. Further particles include sugars, proteins, and water-soluble hydrogels such as polyvinyl pyrrolidone and polyvinyl alcohol. Suitable  
10 polymer materials are as discussed elsewhere herein, the pore size being on the order of about 10 microns to about 80 microns.

As with the other embodiments, when desired, ends 35 of the support component 32 can be exposed either  
15 on one or both of its cylindrical faces in accordance with the needs of the particular repair or treatment to be carried out. With this approach, the exposed ends 35 will assist in maintaining the graft 32 in place by mechanical  
20 engagement between the exposed ends 35 and the vessel being repaired or treated and/or by tissue ingrowth. The anchoring aspect of the exposed ends of the tubular support can be enhanced by continued radial expansion of  
25 the balloon or other deployment means which will permit the exposed ends to expand radially outwardly in an amount somewhat greater than that of the rest of the expandable supportive graft and into the surrounding tissue. It is  
30 also contemplated that mechanical means can be used to assist in joining the exposed ends of this embodiment or of other embodiments to the vessel wall. An illustrative example in this regard is the use of transluminally  
35 delivered staples which can take on the appearance of rivets. Especially advantageous are staples made of an elastomeric material. Illustrated staples are shown at 36 in Fig. 3. They can be incorporated at other locations as well along the graft. One or more windows 37 can be  
formed through the cover and/or liner and/or tubular support in order to feed outside branch arteries or other vessels.

Figs. 5 and 6 illustrate a further embodiment of an expandable supported graft, generally designated as 41. Shown is a mesh tubular support component, generally designated as 42, such as those of the type illustrated in  
5 Palmaz U.S. Patent No. 4,733,665, incorporated by reference hereinto. These are non-woven mesh-type cylinders or slotted tubes wherein most or all of the individual components are either integrally joined together such as by welding or are integrally formed from  
10 a single tube. The resulting endoprostheses are malleable enough so as to be expandable by a balloon of a catheter. Usually, these endoprostheses have particularly high hoop strengths.

Cover 43 and/or liner 44 are made of polymers  
15 rendered porous by phase inversion techniques. In accordance with these techniques, a polymer such as a polyurethane is dissolved in a solvent therefor, for example a water-soluble polar solvent, such as dimethyl acetamide, tetrahydrofuran and the like, in order to form  
20 what is known as a lacquer. A mandrel or rod is dipped into the lacquer. Thereafter, the dipped rod is contacted with an inversion solvent, such as by dipping in water or a mixture of alcohol and water. This inversion solvent must readily dissolve the polymer solvent of the lacquer,  
25 while at the same time being a poor solvent for the polymer. Under these conditions, the polymer coagulates and the polymer solvent of the lacquer is removed and replaced with the inversion solvent. The inversion solvent pulls the polymer solvent out of the polymer on  
30 the rod and forms particularly fine pores having a pore size on the order of about 0.5 micron to about 20 microns. The thus formed liner 44 having phase inversion pores is then dried.

Next, the tubular support component 42 is  
35 secured over the liner 44 and is preferably radially compressed onto and into the liner. Thereafter, the cover 43 having phase inversion pores is formed in accordance

with the same phase inversion steps as discussed hereinabove for preparation of the liner 44. If desired, either the liner or the cover can be omitted. Cover 43 and liner 44 are thus formed in accordance with a displacing step wherein precipitating non-solvent molecules are substituted for non-precipitating solvent molecules dispersed throughout the lacquer coating. This procedure develops advantageous elastic characteristics. Further details regarding the phase inversion procedure are found in Lyman et al. U.S. Patent No. 4,173,689, incorporated by reference hereinto.

Figs. 7 and 8 illustrate an embodiment wherein the graft takes the form of a bifurcated expandable supportive graft, generally designated at 51. Included is a joined-ring bifurcated tubular support 52. Also shown are a bifurcated cover 53, a bifurcated lining 54 and exposed ends 55, 56, 57. This particular bifurcating graft is well-suited for insertion into a branching vessel.

The tubular support includes a plurality of rings or loops 58 connected by flexible interconnections 59. Constructional details of embodiments of the rings or loops 58 and of the flexible interconnections 59 are found in MacGregor U.S. Patent No. 4,994,071, incorporated by reference hereinto. The flexible interconnections 59 join the rings or loops 58 into a configuration having a main body or trunk 61 and one or more branches 62. Flexible interconnections 59 extend longitudinally from the axis of each of the main body or trunk 61 and branch 62, 63. At least one such flexible interconnection joins each branch to the trunk. The loops 58 in the main body are substantially parallel to each other, and the loops 58 in each branch 62, 63 are substantially parallel to each other.

The bifurcated cover 53 and bifurcated liner 54 must each, when provided, be especially elastomeric so as to follow the expansion and contraction of the rings or



loops 58 that takes place during preparation, transluminal insertion, deployment and the like. Cover 53 and liner 54 will also take on a bifurcated construction. In one embodiment, the liner and/or cover for each of the trunk 5 61 and branch 62, 63 are made on a cylindrical mandrel, assembled and joined, such as by suitable biocompatible adhesive, fusion, sewing, suturing or other means of joining and/or sealing. Alternatively, a Y-shaped or branched mandrel can be used. The bifurcating liner is 10 then formed thereon by processes such as those discussed herein, including electrostatic spinning, or dipping followed by elution or phase inversion procedures much in the same manner as described herein when straight cylindrical mandrels or rods are used for constructing the 15 non-bifurcated grafts in accordance with this invention. Fiber winding can also be practiced. Bifurcated cover 53 is made in a similar manner by application of the porous cover material over the bifurcated endoprosthesis.

With reference to the bifurcated endoprosthesis, 20 the bifurcated cover 53 and/or bifurcated liner 54 could be made by fiber winding approaches, such as those described in Wong U.S. Patent No. 4,475,972, the subject matter thereof being incorporated by reference hereinto. Polymer in solution is extruded into fibers from a 25 spinnerette onto a rotating mandrel. The spinnerette is reciprocated along the longitudinal axis of the mandrel at a controlled pitch angle, resulting in a non-woven cylinder wherein each fiber layer is bound to the underlying layer. Control of the pitch angle allows for 30 control of the compliance and kink resistance of the cover and/or liner. In an especially advantageous arrangement when using these fiber spinning techniques in forming an expandable supportive graft in accordance with the general aspects of this invention which has both a liner and a 35 cover, the cover is physically bonded to the liner by the use of an electrostatic field to enable penetration of the cover overlay of fibers through the interstices of the

support components in order to improve the bonding of the cover and/or liner fibers to each other and/or to surfaces of the support component.

5 With more particular reference to balloon  
deployment of expandable supportive grafts, this is  
illustrated with some particularity in connection with  
bifurcated endoluminal grafts in Figs. 9, 10, 11, 12 and  
13. As shown in Fig. 9, two guidewires 64, 65 are  
10 inserted into the bifurcating vessel, each of them into  
different legs 66, 67 of the bifurcating vessel.  
Thereafter, the unexpanded bifurcated expandable  
supportive graft 51 is slipped over the proximal ends of  
the guidewires and routed to the branches of the blood  
15 vessel. The unexpanded bifurcated graft can be introduced  
from an arteriotomy proximal to the bifurcation such as  
from the brachial artery in the arm, or the unexpanded  
bifurcated graft can be introduced from the femoral artery  
in the leg, pushed proximally past the bifurcation and  
20 then pulled back distally into both iliacs to form the  
trunk and bifurcation.

The two branches 62, 63 of the graft 51 are  
routed separately over the guidewires 64, 65,  
respectively, and guided, typically with the help of a  
guide catheter, into the patient until the graft is  
25 positioned as shown in Fig. 9. The graft 51 is initially  
fixed in place as follows. One of the guidewires 65 is  
removed, and a balloon catheter 68 is inserted into the  
main body or trunk 61 and inflated to expand the trunk 61  
into contact with the vessel walls. This deployment is  
30 suitable to secure the graft 51 in place at that location  
of the vessel.

The balloon of balloon catheter 68 is then  
deflated. If this balloon catheter is also suitable for  
use in expanding the branches 62, 63 of the graft 51, same  
35 is then inserted into an unexpanded branch 62 and radially  
expanded as generally shown in Fig. 11. If the balloon of  
catheter 68 is not suitable in this regard, then another

balloon catheter 69 effects this function. Fig. 12 shows inflation of the other branch 63 of the graft 51 in a similar manner. Fig. 13 illustrates the fully deployed and expanded bifurcated support graft 51 positioned in place within the bifurcated location. Alternatively, a bifurcated dilation balloon on a bifurcated catheter (not shown) can replace the single-balloon catheter(s) 68, 69.

When the bifurcated expandable supportive graft is of a spring-into-place type, same will be placed within an overlying and bifurcated restraining guiding catheter or the like and will be passed over two guidewires and contained within the guiding catheter until proper placement within the bifurcating location. This type of bifurcated expandable supportive graft is deployed by being ejected into place by advancing a small inner catheter through the guiding catheter into contact with the bifurcating graft in accordance with the procedure generally used for spring-into-place stents.

The deployment procedures illustrated in Figs. 9 through 13 can be characterized as prograde deployment. Retrograde deployment is also possible. The entire bifurcating graft for retrograde deployment is advanced over a single guidewire through one branch of the blood vessel past the point of bifurcation. A second guidewire is then steered down the opposite limb of the graft, and a snare is used. The snare, which is passed retrograde through the opposite vessel, is then used to pull the guidewire into place. Partial balloon inflation in the unbranched or trunk portion of the blood vessel is then used to draw the graft down into position prior to balloon dilatation of both the trunk and branched portions of the graft. Because blood flow is prograde under these circumstances, the contact between the bifurcation of the graft and the bifurcation of the blood vessel helps to prevent the graft from migrating distally, thus reducing the need for active fixation of the graft to the blood vessel.

Another bifurcated endoprosthesis or expandable supportive graft is generally designated 81 in Fig. 14. Separate components are included. In this case tubular supporting component(s) are, prior to deployment, separate from a trunk component. In this embodiment, a fully independent tubular supporting component 82 is located at the trunk position of the graft 81. A bifurcated stretchable wall 83 is in contact with the independent tubular supporting component 82 as either or both of a cover or liner. In addition to being substantially coextensive with the independent tubular supporting component 82 at a trunk portion 84 thereof, the stretchable wall 83 includes at least two generally tubular stretchable branch sleeves 85, 86 which are initially devoid of a supporting component. Separate tubular supporting components 87, 88 (Figs. 16 and 17) are also included.

Implantation of this bifurcated expandable supportive graft is depicted in Figs. 14, 15, 16 and 17. Dual guidewires 64, 65 can be used to properly position the unexpanded bifurcated graft 81 within the bifurcating vessel as shown in Fig. 14. A balloon catheter 68 or similarly functioning device is inserted into the main body of the device so as to expand the independent tubular supporting component 82 and the trunk portion 84 of the bifurcated stretchable wall 83. This deployment initially secures the bifurcated supporting graft into place at that location of the vessel, as shown in Fig. 15. The balloon catheter is then deflated and removed or positioned for use in the next step.

A suitable balloon catheter 69 or the like is next used to deploy and expand in place a branch tubular expandable supporting component 89, as illustrated in Fig. 16. A similar step deploys and expands in place another branch tubular expandable supporting component 90, as generally shown in Fig. 17. The bifurcated stretchable wall 83 and the expandable supporting components may be

made with the materials and constructions discussed herein and may be subjected to various treatments as discussed.

A further bifurcated endoprosthesis or expandable supportive graft is one in which the separate components are each expandable supportive graft members. These separate components are illustrated in Fig. 18 through Fig. 24, which also illustrate their separate deployment with respect to each other within an aortic trunk. Same is shown in connection with treating an abdominal aorto-iliac aneurysm. The device includes a trunk component 101 designed to extend from below the renal arteries to a location between the proximal neck of the aneurysm and the aorto-iliac bifurcation. It will be understood that this trunk component could also be shorter so that it terminates just below the proximal neck of the aneurysm, or it could be made longer so that it extends closer to the aorto-iliac bifurcation site. In addition, the component bifurcated expandable supportive graft of this embodiment is self-expanding and is deployed by means an introducer containing compressed expandable supportive graft components.

More particularly, and with reference firstly to Fig. 18, a guidewire 102 is first inserted in accordance with known procedures so as to traverse the aneurysm 103. Next, an introducer, generally designed as 104 having the trunk component therewithin in a radially compressed state is inserted over the guidewire 102. The introducer is maneuvered such that it is properly positioned as desired, in this case at a location distal of the distal end of the aneurysm. Then, the sheath 105 of the introducer is withdrawn, such as by sliding it in a proximal direction while the remainder of the introducer 104 remains in place. As the sheath is withdrawn, the trunk 101 expands, eventually achieving the deployed or implanted position shown in Fig. 19. At this stage, the distal portion 106 of the trunk is well anchored into the blood vessel wall and is suitably deployed.

Fig. 20 shows an introducer, generally designated as 107, having an independent tubular expandable supportive graft leg component 108 (Fig. 21) radially compressed therewithin. In this illustrated embodiment, this leg component is an iliac component of the bifurcated supportive graft being assembled within the body vessel. The introducer 107 is advanced until this iliac component is moved into a leg 109 of the already deployed trunk component 101. This positioning is illustrated in Fig. 21. It will be noted that the iliac tubular supportive graft component 108 extends from well within the leg 109 to a location proximal of the aneurysm in the iliac artery 110.

In a next step, a guidewire 111 is passed through the appropriate vessel to iliac artery 112 until it crosses the aneurysm 103, while passing through the other leg 113 of the deployed trunk component 101. Introducer generally designated as 114 is advanced over the guidewire 111 and into leg 113. Introducer 114 contains another tubular supportive graft leg component 115 (Fig. 24), which is another iliac component. With the introducer 14 removed, the previously radially compressed iliac component 115 expands radially and is deployed. At this stage, the entirety of the bifurcated endoprosthesis or expandable supportive graft in accordance with this embodiment is fully deployed and assembled together.

Fig. 25 shows a typical aneurysm repair as discussed herein after a lapse of time. The aneurysm eventually heals and contracts as generally shown at 116. Blood flow is, of course, through the implanted bifurcated component endoprosthesis from the abdominal aorta 117 and to both of the iliac arteries 110 and 112.

It will be noted that it is not required to actually attach the trunk component 101 and the tubular components 108, 115 together. In other words, these components are generally telescopically positioned with respect to each other. This telescopic feature allows

some slippage between the trunk component and the tubular leg components, thereby providing a telescopic joint which is a slip bearing. It will be appreciated that it is generally desirable to firmly anchor portions of the bifurcated endoprosthesis within healthy vessel wall tissue. This can be achieved by the hoop strength of the supportive graft or by taking measures to enhance hoop strength at its ends, or by providing grasping structures such as hooks, barbs, flared ends and the like. During pulsetile blood flow and possibly during exercise by the person within which the endoprosthesis is implanted, tension and elongation forces are imparted to the endoprosthesis. In structures that do not have a telescopic joint or some other means to relieve the stress developed by this tension, a considerable amount of stress can be placed on the anchoring sites and/or the attachment components, potentially allowing for dislodgement at the anchoring sites or breakage of attachment components.

Fig. 26 illustrates a trunk component 101a. It includes a common trunk portion 118 and a bifurcated portion, generally designated as 119. The bifurcated portion includes the legs 109 and 113. Trunk component 101a includes a stent or tubular supporting component 121, as perhaps best seen in Fig. 27. Also included is a liner, generally designated as 122. This liner 122 has a body portion 123 and the legs 109 and 113 which take on a combined configuration resembling a pair of pants.

Each leg 109, 113 is secured to the generally tubular stent component 121 at outside portions thereof, particularly at adhesion zones 124 and 125. The remainder of the leg portions 109 and 113 are not so bonded to the stent portion 121. This facilitates formation of the leg portions, which are typically pinched along the length of the legs in order to form an internal seam 126. Leg openings 127 and 128 are thereby generally defined between this seam 126 and the adhesion zones 124 and 125.

In Fig. 28, means are included in the trunk component 101b which provides enhanced securement upon implantation. A stent component 129 is included which has a substantially higher pitch angle (for example, between about 140° and 180°) than does the stent portion 121b therebelow within which the legs are positioned (for example, at a pitch angle of between about 70° and 90°). This higher pitch angle zone imparts a greater hoop strength upon deployment than does the stent 121 of the trunk component 101a. A barb 130 is also shown in order to further assist in securement of the endoprosthesis to the artery wall. When desired, the barb-type of structure can be a backing ring and barb formed out of the stent strand during its formation into the cylindrical supportive member.

Any of the various expandable supportive endoluminal graft, or stent graft, constructions discussed or referred to herein can be used in order to construct devices in accordance with this embodiment. Other modifications may also be incorporated, including tubes having stepped diameters or conical ends. The stent component can be made with flat wires or with pairs of wires or multifilament wires. They can incorporate balloon expandable stents, self-expanding stents, and combinations of balloon expandable stents and self-expanding stents. Use can be made of ancillary equipment such as endoluminal stapling devices or suturing devices in order to facilitate securement at the aneurysm neck, for example. Also, a portion of the stent component without a liner component or the like thereon can project at the proximal end of the endoluminal component, such as at a location which would be above the renal arteries. The objective is also to help to secure the device in place.

A preferred use for the bifurcating endoluminal grafts discussed herein is for insertion into a branching blood vessel. Same is typically suitable for use in the



coronary vasculature (the right, left common, left anterior descending, and circumflex coronary arteries and their branches) and the peripheral vasculature (branches of the carotid, aorta, femoral, popliteal arteries and the like). These bifurcated devices are also suitable for implantation into other branching vessels such as in the gastrointestinal system, the tracheobronchial tree, the biliary system, and the genitourinary system.

It will be appreciated that the expandable supportive grafts in accordance with the present invention will dilate and/or support blood vessel lesions and other defects or diseased areas, including at or in proximity to sites of vascular bifurcations, branches and/or anastomoses. The expandable supportive graft is an integral structure that incorporates the expandable support component into the wall or walls of the elastomeric graft. Covers and/or linings that make up the grafts interface with body components that facilitate normal cellular invasion without stenosis or recurrent stenosis when the graft is in its expanded, supportive orientation. The graft material is inert and biocompatible. The expandable supportive graft can be expanded from a smaller diameter insertion configuration to a larger diameter implantation configuration by the application of radially outwardly directed forces provided by expanding the endoprosthesis with a balloon catheter, using an ejection tube that allows a spring-into-place structure to be deployed from the end of a catheter into its expanded configuration, or by using a support component made of certain alloys exhibiting thermotransition characteristics by which they expand when heated, for example.

In addition to the support component structures illustrated herein, support structures include others having spring characteristics and those having a coil with circumferentially oriented fingers such as shown in Gianturco U.S. Patent No. 4,800,882, incorporated by

reference hereinto. Materials include, either alone or in combination, metals or metal alloys, polymers, carbon and ceramics. Exemplary metallic members include stainless steel, titanium, tantalum, Nitinol, Elgiloy (trade name) and NP35N (trade designation), which can provide desired degrees of springiness, malleability and/or response to temperature changes. Exemplary polymers include polyurethanes, silicone rubbers, polyether sulfones, fluoroelastomers, polyimides, polycarbonates, polyethylenes, polylactic acid, polyglycolic acid, polyacrylates, and the like and combinations and copolymers thereof which provide a variety of abilities to bioabsorb or biodegrade or to be totally inert. Any of a variety of these endoprostheses can be combined with any of a variety of the graft cover and/or liner configurations in order to tailor the expandable supportive graft to meet specific needs. Also, combinations can be obtained, such as providing phase inversion pores and salt elution pores on different locations of the graft component to take advantage of the pore size difference between these two types of graft techniques and/or to provide better tissue growth at one location than at another.

With reference to the material out of which the cover and/or liner of the grafts in accordance with the present invention are made, the material must be stretchable and/or support component so that it will follow the movement of the endoprosthesis between its fully collapsed and expanded or implanted configurations. Polyurethanes are preferred. Particularly preferred is an especially crack-resistant, elastomeric and pliable polycarbonate urethane as described in Pinchuk U.S. Patents No. 5,133,742 and No. 5,229,431, incorporated by reference hereinto, available from Corvita Corporation under the CORETHANE® trademark. Also suitable are polycarbonate polyurethane covers and liners coated with a thin layer of silicone rubber material as described in

Pinchuk U.S. Patent No. 4,851,009, incorporated by reference hereinto.

In addition, various surface treatments can be applied to render the surfaces of the expandable supported graft more biocompatible. Included are the use of  
5 pyrolytic carbon, hydrogels and the like. The surface treatments can also provide for the elution or immobilization of drugs such as heparin, antiplatelet agents, antiplatelet-derived growth factors, antibiotics,  
10 steroids, and the like. Additionally, the coating and/or liner can be loaded with drugs such as those discussed herein, as well as lytic agents in order to provide local drug therapy.

The expandable supportive graft of the present invention is capable of being tailored to meet specific needs, depending upon the particular defect or disease being addressed, such as occlusion, stenosis, aneurysm, arteriovenous fistula, trauma and the like, as well as upon the anatomy of the vessel. For example, it can be  
15 desirable to have the support component of the expandable supportive graft at locations other than throughout the entirety of the graft as specifically illustrated in Figs. 1 through 4 hereof. The bifurcated graft of Figs. 7 and 8 shows some separation along the support component, such as  
20 between the trunk 61 and the branches 62, 63. It is also possible, with the grafts in accordance with the present invention, to provide an expandable graft having its supportive property emanating from one or more support components, while thereby providing an adjoining graft  
25 cylindrical portion which is supported primarily by its close proximity to a support component which can be presented at one end, both ends, or spaced along the expandable supportive graft in accordance with invention.

Such a structure is generally illustrated in  
35 Fig. 5, wherein an adjoining graft cylindrical portion 71 is positioned between a first support component 72 and another or second support component 73. The expandable

supportive graft in accordance with the present invention provides the tailorability advantage of being able to vary within a single graft the configuration, structure and properties of the support component or components of the graft. These various properties allow the expandable supportive graft to be tailored in accordance with particular needs of the disease, defect or damage being treated. For example, support may be particularly desirable at one location being treated, while a less rigid supportive area is needed at another, generally adjoining location. By the expandable supportive graft in accordance with this invention, a single graft can be deployed in order to effect two or more different functions. By achieving multiple support and/or repair functions with a single device, possible trauma to the patient is minimized by reducing the number of transluminal passages needed to address a situation that could otherwise require separate stents or grafts, each of which is separately deployed or implanted.

With further reference to the tailorability aspects, the present invention reduces the risk of compromising the patency of the passageways being treated. This is particularly true in treating lesions at or near vascular bifurcations, branches and/or anastomoses. Typical difficulties which can be avoided by the present invention include displacing of diseased tissue, vessel spasm, dissection with or without intimal flaps, thrombosis, embolism, and the like. Another suitable use is for dilating and/or supporting vascular graft bifurcations and the like. Additionally, lesions affecting vascular trifurcations can be treated. Also treatable are obstructed openings characterized by exaggerated cicatrization, abnormal cellular growth (subintimal fibromuscular hyperplasia and the like) or arterial or venous stenosis. Moreover, these supportive grafts can be used to reinforce vascular walls, weakened by pathological processes, for example, by dissection, as

in the case of aneurysms. The grafts can also obliterate congenital or acquired arteriovenous communications, and they can be applied in intrahepatic portal-caval shunts. The grafts also can maintain biological pathways open, such as the digestive, biliary, pancreatic and urinary tracts, and they help to limit the intraluminal growth of pathological processes such as fibrosis or cancer.

It is also desirable to incorporate a radiopaque marker in the endoluminal graft specifically in the area of the trunk defining the bifurcation. The purpose of the marker is to allow one well versed in the art of implanting these devices to see, under angiography, where the bifurcation is precisely located so as to deploy the leg endoluminal grafts within the trunk sockets provided. The radiopaque marker may be in the form of a metallic powder, such as bismuth subcarbonate, tantalum, tungsten, platinum, gold, barium sulfate and the like, dispersed in a binder such as silicone rubber, polyurethane, epoxy and the like, wherein the binder containing the metal powder is painted or printed onto the graft in the desired location. Alternatively, radiopaque sutures or wires can be sewn into the graft at the bifurcation to allow visualization of the device. Similarly, the proximal ends of the leg endoluminal grafts can be painted, printed or sewn with similar markers to aid in visualizing and placing the leg stents during deployment.

#### Example I

A vascular expandable supportive endoluminal graft was made using a 16 mm diameter, 12 cm long Wallstent® device as the support component in the following manner. A grounded 16 mm mandrel was rotated on a spinning machine at 500 RPM, and a spinnerette with 30 orifices was reciprocated along the axis of the mandrel at 13.8 inches/second while applying 40,000 volts to the spinnerette. Polycarbonate urethane, in dimethyl acetamide solution (45% solids) was extruded from the

spinnerette at 0.123 ml/min, the fibers coming onto the mandrel in random fashion to form a mat-like structure having randomly shaped pores. The environment in the spinning chamber was controlled such that sufficient solvent from the urethane solution evaporated off during spinning to enable the fibers to be bond to underlying fibers during each transverse of the spinnerette. After 300 passes of the spinnerette, the spinning procedure was stopped and the mandrel with the spun polycarbonate urethane mat was removed from the machine and cured at 110° C. for 16 hours. The tubular mat still on the mandrel was trimmed to the appropriate size and the Wallstent® device was sheathed over the mesh and the ends taped down. Another 10 passes of polycarbonate urethane were spun over the Wallstent® device, and the fibers, while still wet, were immediately pressed through the interstices of the Wallstent® device with a silicone rubber sponge, such that the fibers bonded to the underlying fibers of the urethane mat, thereby capturing the Wallstent® device within the urethane wall. The assembly was then cured for an additional 3 hours at 110° C., after which the assembly was removed from the mandrel. The expandable supportive endoluminal graft formed in this manner had the bulk of the urethane mesh on the inside of the stent. This endoprosthesis is suitable for repairing aortic aneurysms.

#### Example II

A bifurcated aortic expandable supportive endoluminal graft is made in the following manner. An aortic trunk supportive endoluminal graft is fabricated using a 16 mm diameter, 12 cm long support component. First, a 16 mm mandrel is rotated on a spinning machine at 500 rpm, and a spinnerette with 30 orifices reciprocated along the axis of the mandrel at 13.8 inches/second. Polycarbonate urethane, in dimethyl acetamide solution (45% solids) is extruded from the spinnerette at 0.123

ml/min and wound onto the rotating mandrel such that the fibers form a 50° pitch angle in relation to the axis of the mandrel. The environment in the spinning chamber is controlled such that sufficient solvent from the urethane solution evaporates off during spinning to enable the fibers to bond to underlying fibers during each transverse of the spinnerette. The thus formed spun polycarbonate urethane mesh has a length of about 16 cm, is removed from the machine and is cured at 110° C. for 16 hours. The support component is sheathed over the mesh still on the mandrel with a 4 cm excess length of tubular mesh protruding beyond the support component. Another 10 passes of polycarbonate urethane were spun over the tubular mesh, support component, but not over the 4 cm excess length of the internal tubular mesh, and the fibers, while still wet, were immediately pressed through the interstices of the support component with a silicone rubber sponge, such that the fibers bonded to the underlying fibers of the urethane mesh, thereby capturing the support component within the urethane wall. The assembly was then cured for an additional 3 hours at 110° C., after which the assembly was removed from the mandrel. The supportive endoluminal graft formed in this manner has fiber diameters of 10 to 20  $\mu$  and pore sizes ranging from 10 to 60  $\mu$ . The excess tubular mesh which protrudes from one side of the assembled endoprosthesis is then slit and sewn down the center such that the tube is bifurcated into two smaller tubes, thereby resembling a pair of short pants. The aortic trunk endoprosthesis is pulled down and sheathed on an introducer catheter, maneuvered into the aorta of a dog, via the dog's femoral artery for deployment in the abdominal aorta. Two smaller stents, of 8 mm diameter, are also pulled down onto introducer catheters and maneuvered, through each femoral artery for deployment into the "pant legs" of the aortic trunk. The resultant bifurcated endoprosthesis is for limiting further dilation of an abdominal-iliac aneurysm.

Example III

A bifurcated expandable supportive endoluminal graft is provided for deployment within and repair of aorto-iliac aneurysms. A generally tubular metallic stent of the self-expandable type is adhered to the outside of a porous spun liner as follows. The graft is wound or spun from filaments deposited onto a rotating mandrel in order to form a cylindrical graft having crossing strands generally adhered together. The resulting inner liner, after it is dried, has a stent component placed over it. Then, an area of the stent is masked, such as with a piece of tape, at the location where an internal seam is to be positioned in the trunk component of the supportive endoluminal graft. The masking can take on a shape on the order of the triangular areas illustrated in Fig. 27, with the upper apex forming the "crotch" of the "pants". Additional fibers are then spun over the entire stent and pressed through the stent intersticies to be certain that the stent is secured to the liner. This continues until all areas of the stent are well-bonded except for the masked area. After removal of the mandrel and of the masking material, the initially formed inner liner is free to be pinched along its length and sutured, sewed and/or glued and the like to form two distinct leg portions and a trunk portion of the liner. The resulting trunk component is as generally shown in Figs. 26 and 27.

The leg components of the bifurcated expandable supportive endoluminal graft in accordance with this Example are individually made in a similar manner. The liner is formed by spinning compliant fibers over a rotating mandrel, a tubular stent component is positioned thereover and secured in place, and additional fibers are wound with the rotating mandrel. The stent is thus encapsulated between the liner fibers and the cover fibers, preferably with the aid of a soft roller or sponge to force the cover strands into the intersticies of the stent component and securement to the underlying liner



fibers. After removal from the mandrel, the resulting tubular supported graft component, suitable for use as both the iliac components, is trimmed to proper length.

5                   It will be understood that the embodiments of  
the present invention which have been described are  
illustrative of some of the applications of the principles  
of the present invention. Various modifications may be  
made by those skilled in the art without departing from  
10                   the true spirit and scope of the invention.

Claims

1. A multiple-component bifurcating expandable supportive endoluminal graft comprising:

5 a plurality of expandable supportive endoluminal components which are deployed individually at a selected location within a body vessel, each said supportive endoluminal graft component being radially compressible for endoluminal insertion and radially expandable for deployment at a desired location within a body vessel;

10 one of said expandable supportive endoluminal components is a trunk component, said trunk component including a tubular supporting member and a trunk liner positioned along said tubular supporting member, said trunk liner having a generally cylindrical body portion and at least two leg portions, each said leg portion defining a leg opening;

15 at least one other of said expandable supportive endoluminal components is a generally cylindrical supportive leg component; and

20 said generally cylindrical supportive leg component and one of said leg portions of the trunk component, when said leg component and trunk component are deployed within the body vessel, are telescopically positioned with respect to each other.

2. The supportive endoluminal graft in accordance with claim 1, wherein said generally cylindrical supportive leg component has an end portion which, when deployed, is positioned within said leg opening of the trunk component.

3. The supportive endoluminal graft in accordance with claim 1, wherein said plurality of expandable supportive endoluminal components are self-expanding.

4. The supportive endoluminal graft in accordance with claim 1, wherein said plurality of expandable supportive endoluminal components are deployed by a radially expandable device.
5. The supportive endoluminal graft in accordance with claim 1, wherein said generally cylindrical supportive component includes a generally cylindrical supporting member and a generally cylindrical liner secured therealong.  
5
6. The supportive endoluminal graft in accordance with claim 1, wherein said trunk liner is a stretchable wall of essentially inert biocompatible material, said stretchable wall being attached to a portion of the internal surface of the trunk component tubular supporting member, said stretchable wall having a diameter size that expands with said trunk component tubular supporting member.  
5
7. The supportive endoluminal graft in accordance with claim 5, wherein said liner of the generally cylindrical supportive leg component is a stretchable wall of essentially inert biocompatible material, said stretchable wall being applied onto at least the internal surface of the generally cylindrical tubular supporting member of the leg component.  
5
8. The supportive endoluminal graft in accordance with claim 1, wherein said leg portions of the trunk liner extend longitudinally beyond said tubular supporting member of the trunk component.
9. The supportive endoluminal graft in accordance with claim 8, wherein said leg portions are separated from each other.

10. The supportive endoluminal graft in accordance with claim 1, wherein said leg portions of the trunk liner are longitudinally generally coextensive with said tubular supporting member of the trunk component.
11. The supportive endoluminal graft in accordance with claim 10, wherein an outside section of each of said leg portions of the trunk liner is secured to said tubular supporting member, while inside sections of each of said leg portions are secured to each other along an internal seam.
12. The supportive endoluminal graft in accordance with claim 1, wherein said generally cylindrical supportive leg component, when deployed, is telescopically slidably positioned within one of said leg portions of the trunk component.  
5
13. The supportive endoluminal graft in accordance with claim 5, wherein said liner of the leg component and said trunk liner are each a stretchable wall made from a porous elastomeric material that provides a structure which allows normal cellular invasion thereinto from the body vessel when implanted therewithin.  
5
14. The supportive endoluminal graft in accordance with claim 13, wherein said porous elastomeric material of each stretchable wall is an elastomeric polymer.
15. The supportive endoluminal graft in accordance with claim 13, wherein said porous elastomeric material of said stretchable wall is a polycarbonate urethane.
16. The supportive endoluminal graft in accordance with claim 13, wherein said porous elastomeric material is coated with a thin layer of silicone rubber.

17. The supportive endoluminal graft in accordance with claim 5, wherein said trunk liner and said liner of the leg component are each a stretchable wall along the internal surface and the external surface of each tubular supporting component.
- 5
18. The supportive endoluminal graft in accordance with claim 1, wherein an exposed longitudinal end of said tubular supporting member extends longitudinally beyond and is not completely covered by said liner.
- 10
19. The supportive endoluminal graft in accordance with claim 17, wherein said tubular supporting member has a plurality of open areas therealong, and said stretchable wall along said external surface of the tubular supporting component is bonded to said stretchable wall along said internal surface of the tubular supporting component at locations defined by said open areas of the tubular supporting component.
- 5
20. The supportive endoluminal graft in accordance with claim 1, wherein said tubular supporting member has a plurality of open areas therealong, and an attachment component passes through one of said open areas of said tubular supporting component.
- 5
21. The supportive endoluminal graft in accordance with claim 1, wherein said tubular supporting component includes a plurality of wire strands with open areas therebetween.
22. The supportive endoluminal graft in accordance with claim 21, wherein said wire strands of the tubular supporting component are generally sinusoidally configured wire that is helically wound into the tubular supporting component, said wire defining
- 5

therebetween said open areas of the tubular supporting component.

23. The supportive endoluminal graft in accordance with claim 21, wherein said wire strands of the tubular supporting component are shaped as intersecting elongated lengths integral with each other and defining said openings therebetween to form a mesh-shaped tubular supporting component.
24. The supportive endoluminal graft in accordance with claim 1, wherein the endoluminal graft is subjected to surface treatment for enhanced biocompatibility or for drug therapy.
25. The supportive endoluminal graft in accordance with claim 1, wherein said trunk component includes a projecting securement member.
26. A multiple-component bifurcating expandable supportive endoluminal graft comprising:  
a plurality of expandable supportive endoluminal graft components which are deployed individually at a selected location within a body vessel, each said supportive endoluminal graft component being radially compressible and radially expansible;  
one of said expandable supportive endoluminal graft components being a trunk component having a longitudinal axis, an internal surface disposed toward the longitudinal axis, and an external surface spaced outwardly from and shaped complementarily with said internal surface, said trunk component having a network of land areas with open areas defined therebetween,  
two other of said expandable supportive endoluminal graft components being a generally cylindrical supportive leg component;

20 said trunk component having a stretchable wall of  
essentially inert biocompatible material, said  
stretchable wall being applied onto at least one of  
said internal surface and said external surface of  
the tubular supporting component, said stretchable  
25 wall having an extension portion that extends beyond  
said tubular supporting component thereof; and

30 said extension portion of the stretchable wall is  
branched into at least two generally tubular leg  
portions of stretchable wall material, each said leg  
portion being sized and shaped to receive one of said  
generally cylindrical supportive leg components.

27. A method for implanting a multi-component bifurcating  
expandable supportive endoluminal graft, comprising  
the steps of:

5 providing a trunk component having a tubular  
supporting member and a trunk liner positioned along  
the tubular supporting member, the trunk liner having  
a generally cylindrical body portion and at least two  
leg portions, each leg portion defining a leg  
opening;

10 inserting the trunk component generally at a  
bifurcation site within a body vessel, and expanding  
the trunk component to engage a main vessel path of  
the vessel body;

15 providing a generally cylindrical supportive leg  
component which includes a tubular supporting member;

20 inserting the generally cylindrical supportive  
leg component into the body vessel at a location  
between a leg portion of the trunk component and a  
branched pathway associated with a main pathway of  
the body vessel, and expanding the leg component so  
as to be deployed at said location;

providing another generally cylindrical  
supporting leg component having a tubular supporting  
member; and

25           inserting the another generally cylindrical  
supportive leg component into the body vessel at a  
location between the other leg portion of the trunk  
component and another branched pathway associated  
with the main pathway of the body vessel, and  
30           expanding the component so as to be deployed at said  
location in order to form a bifurcated supportive  
endoluminal graft at a bifurcation site within the  
body vessel.

28.   The method in accordance with claim 27, wherein each  
step of providing the leg component provides a leg  
component which includes a liner and a tubular  
supporting member, and each such leg component is  
5           deployed inside of a respective one of the leg  
portions of the trunk component, each of which is  
generally coextensive with the tubular supporting  
member of the trunk component.

29.   The method in accordance claim 27, wherein said step  
of providing the trunk component provides leg  
portions that project beyond the tubular supporting  
member of the trunk component, and the steps of  
5           inserting the leg component insert a supportive stent  
respectively within the leg portions of the trunk  
component.



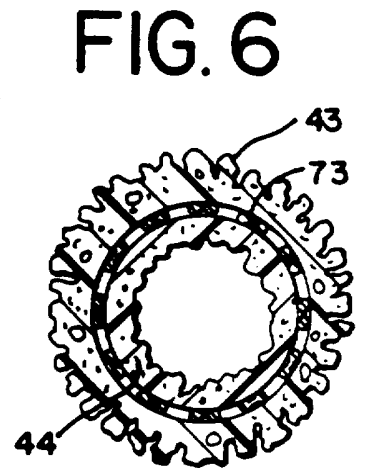
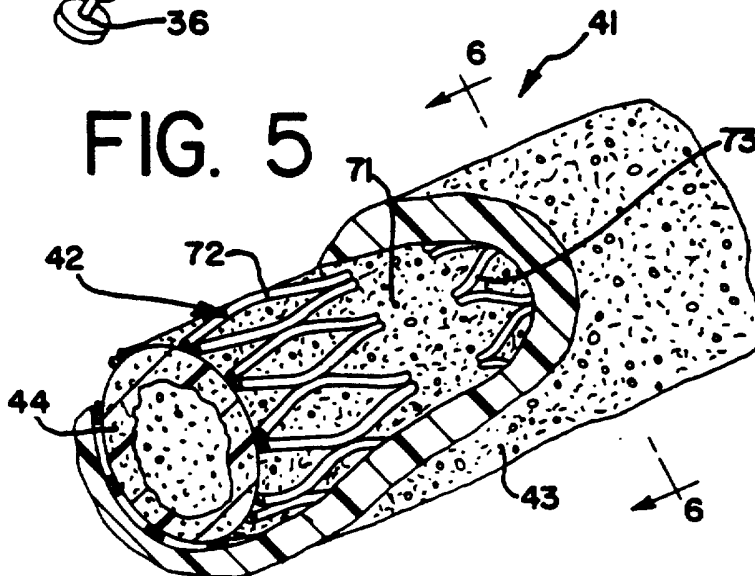
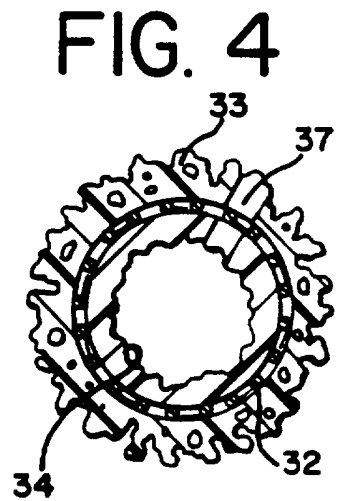
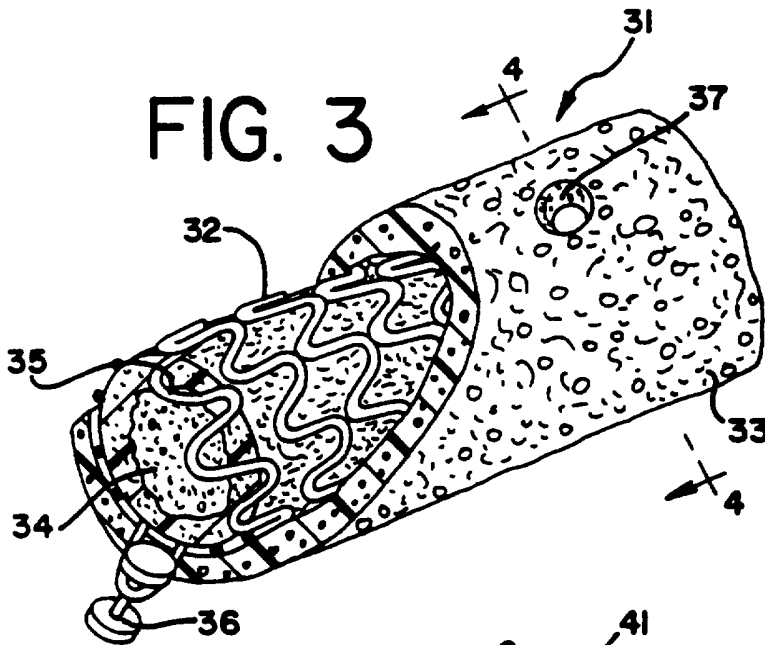
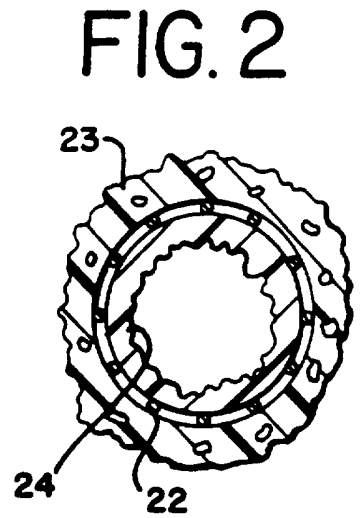
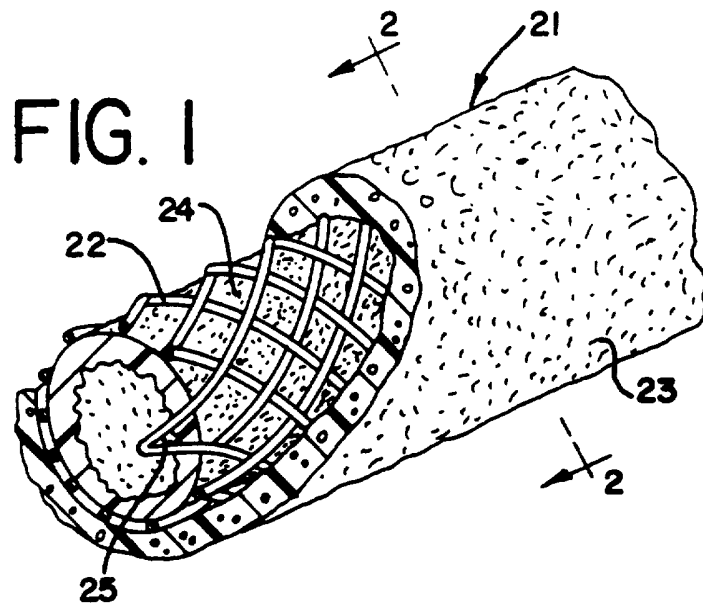

FIG. 7

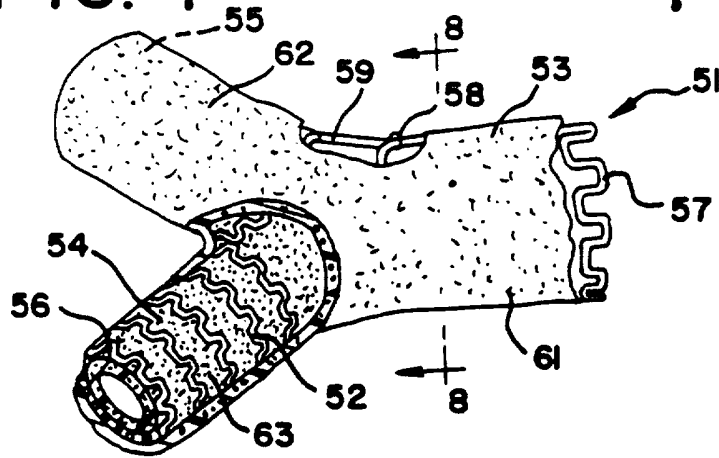

FIG. 8

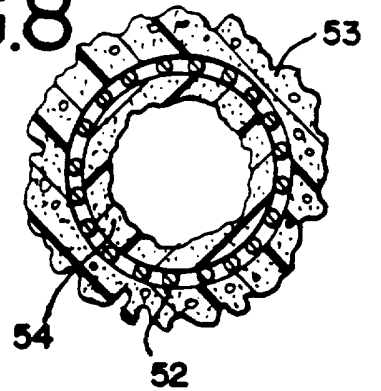

FIG. 9

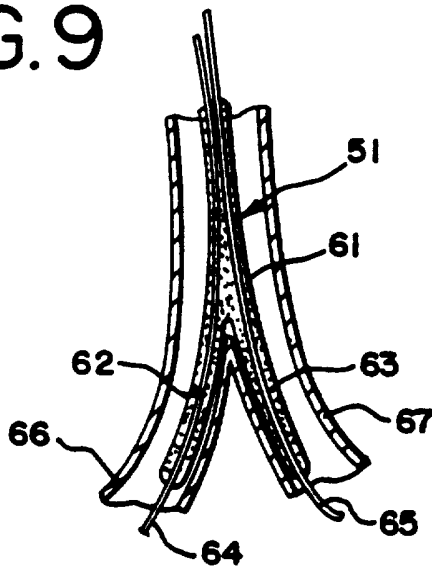

FIG. 10

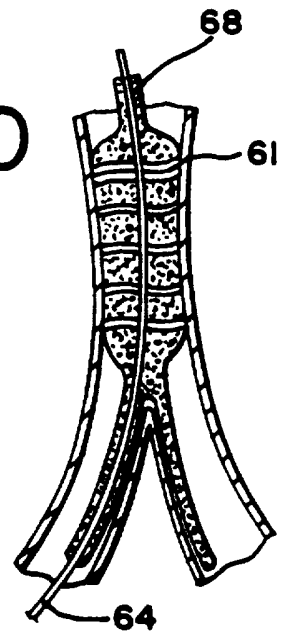

FIG. 11

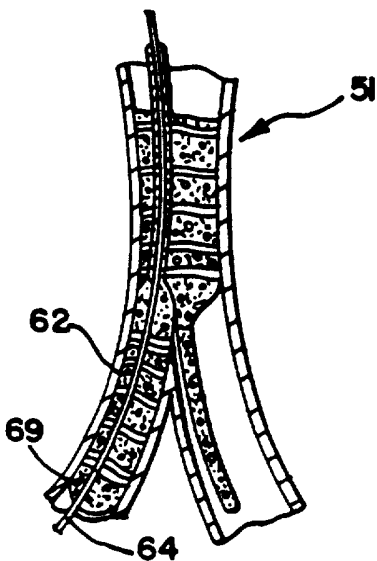

FIG. 12

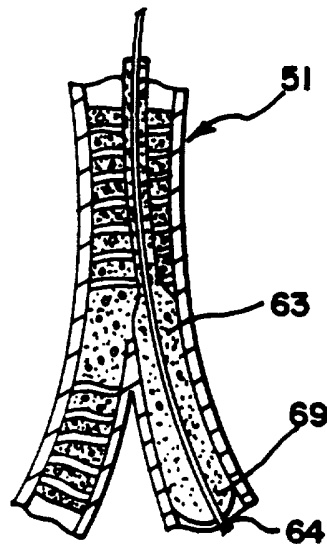

FIG. 13

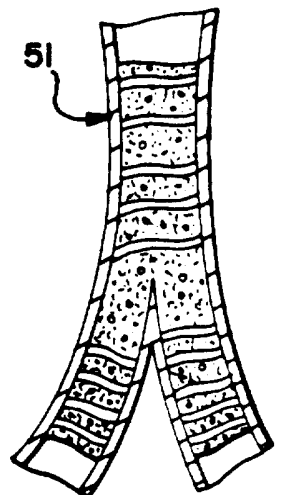

FIG.14

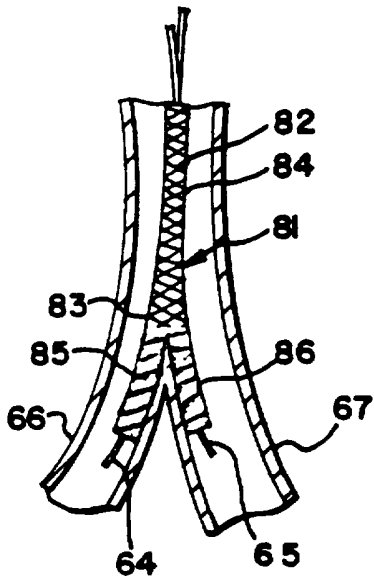

FIG.15

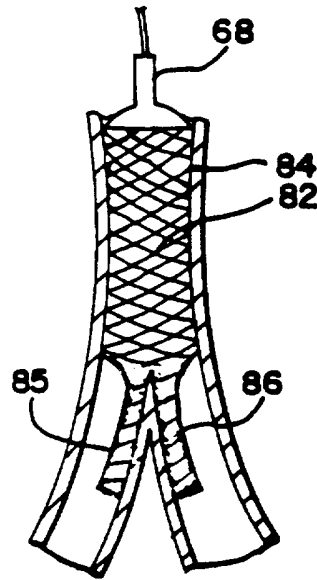

FIG.16

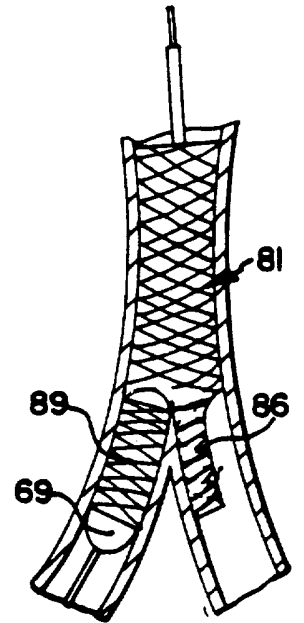
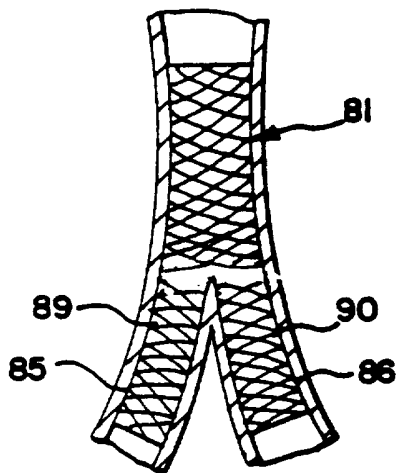
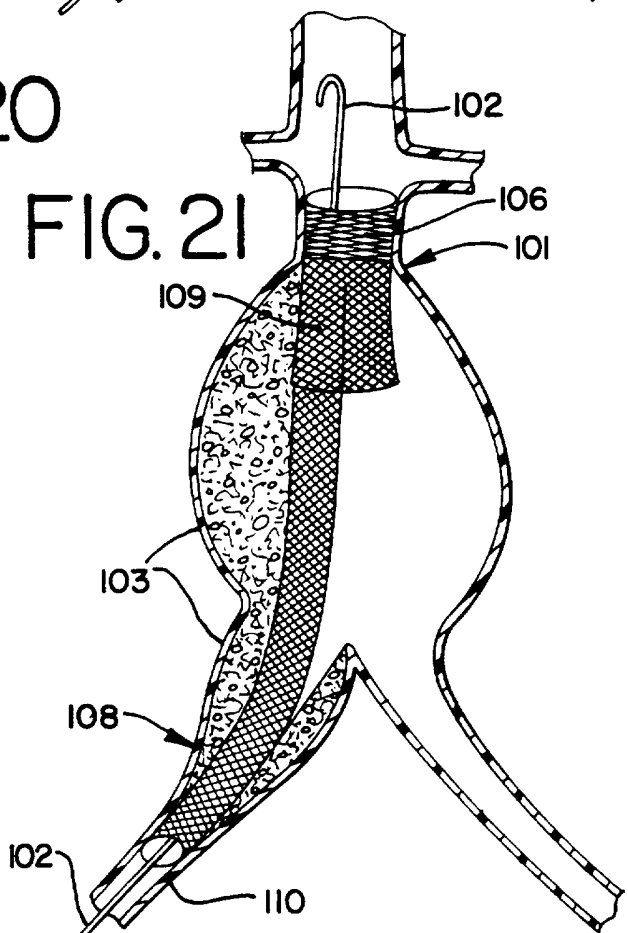
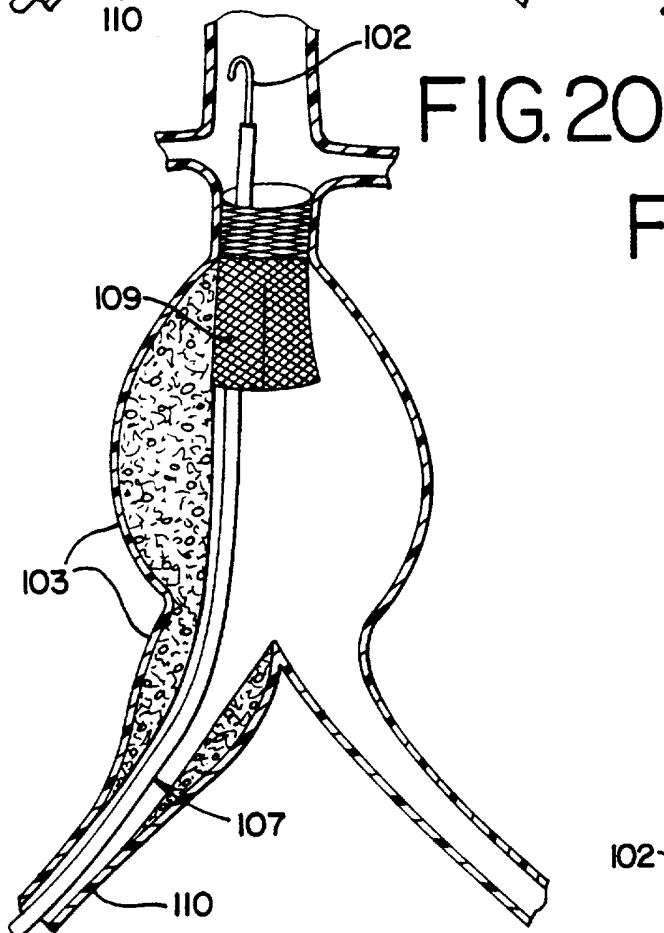
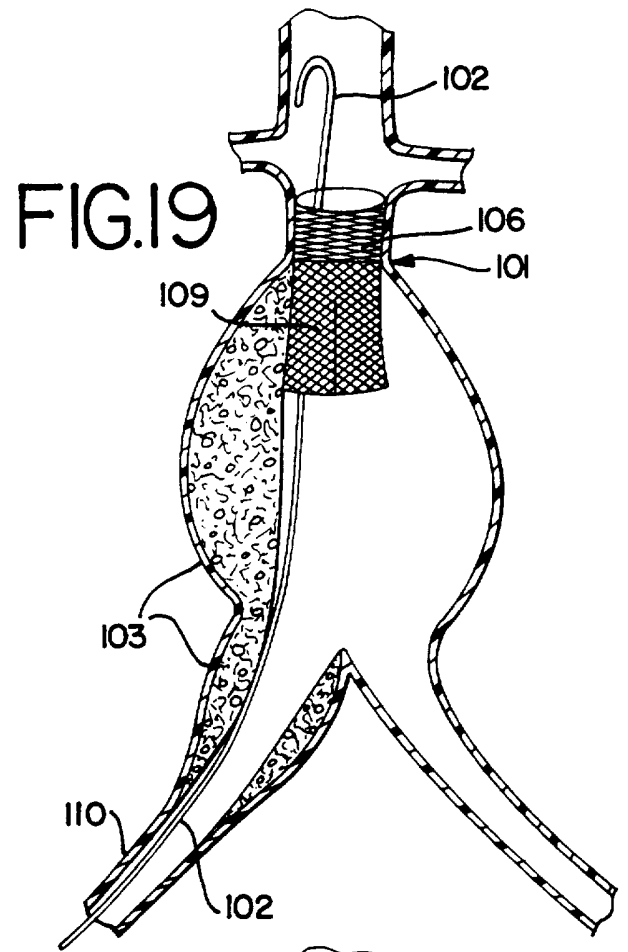
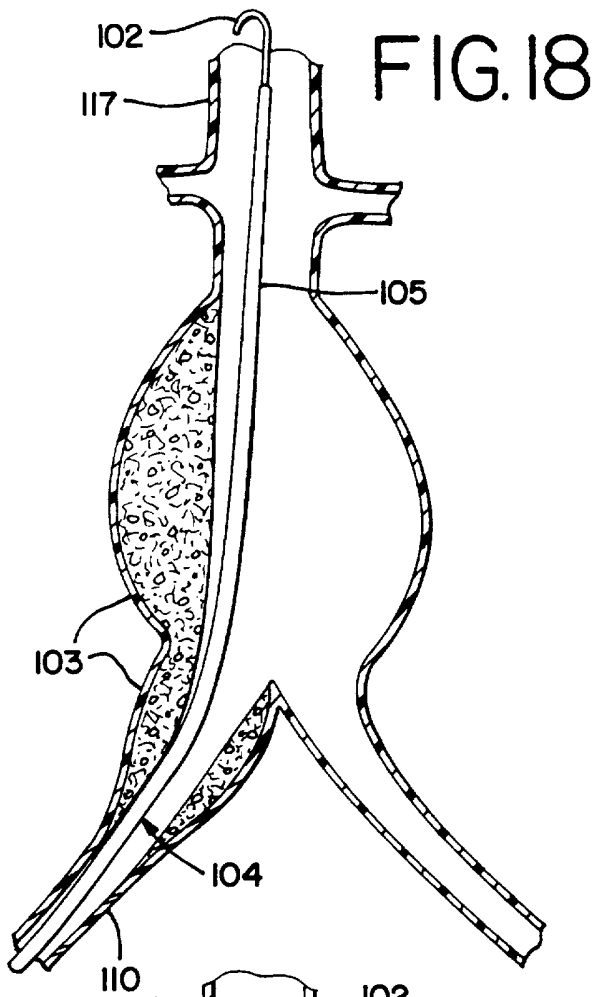

FIG.17





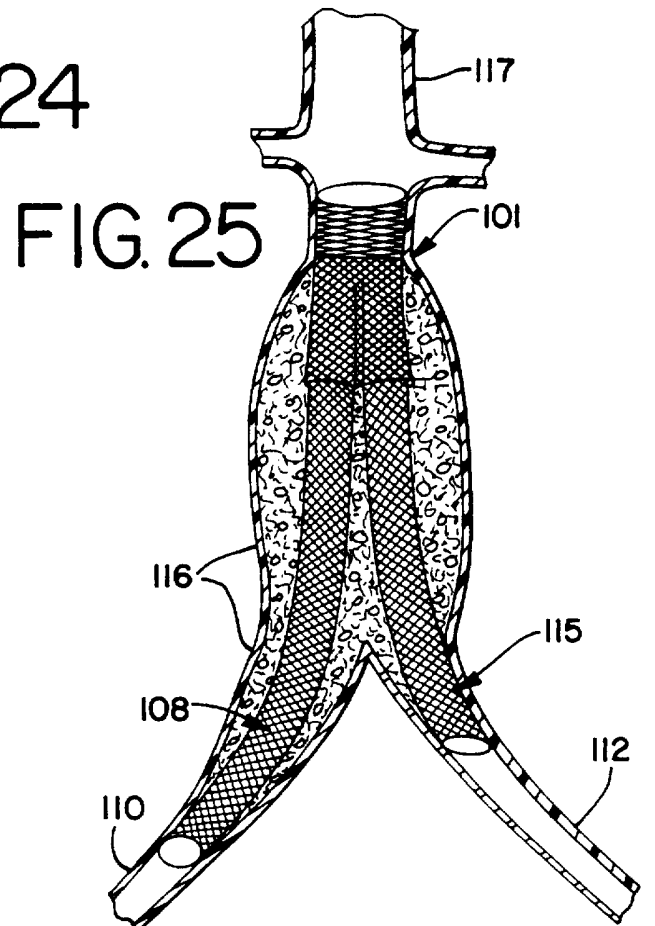
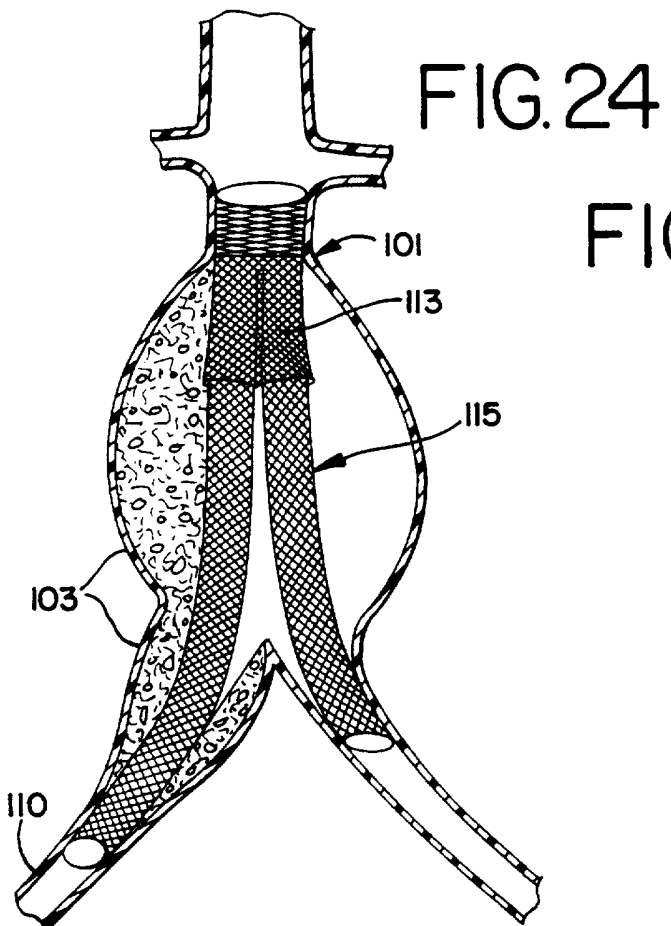
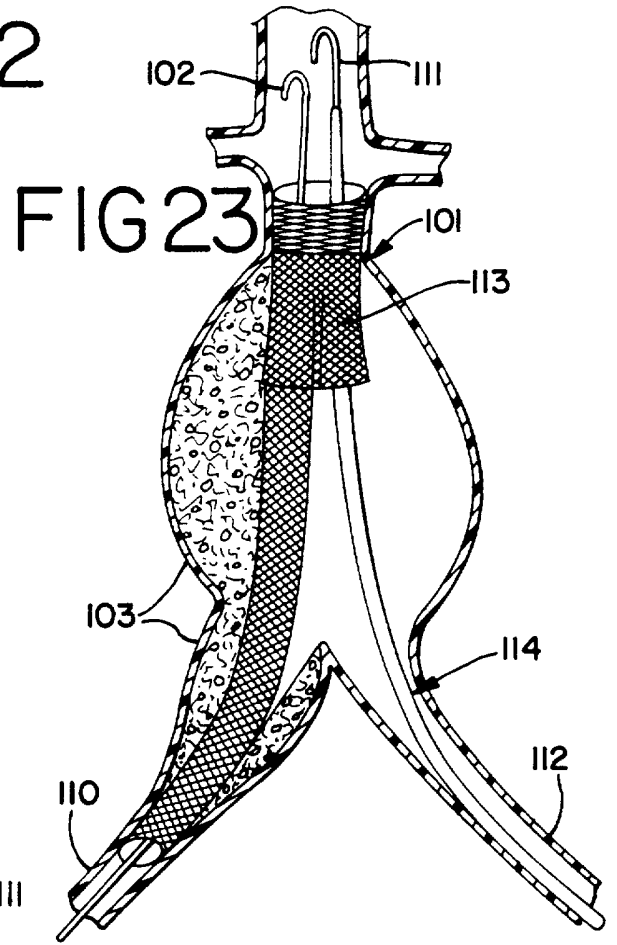
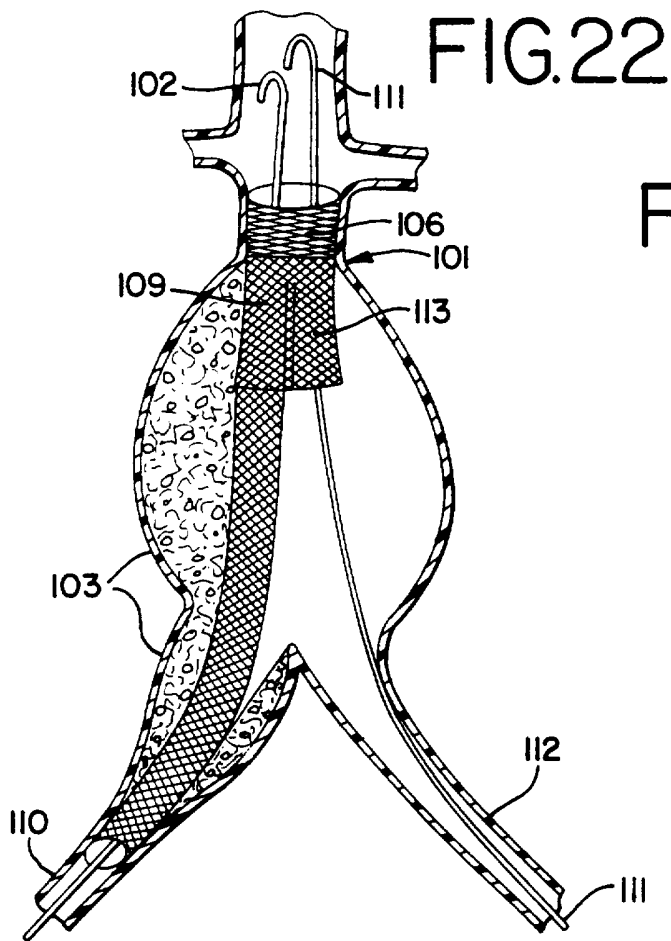

FIG. 26

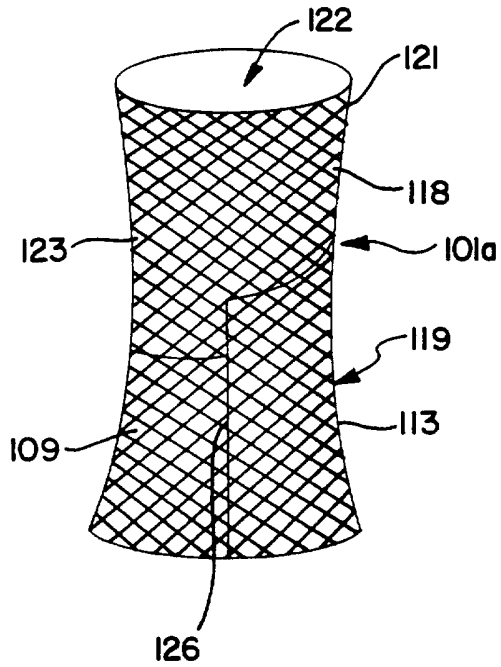

FIG. 27

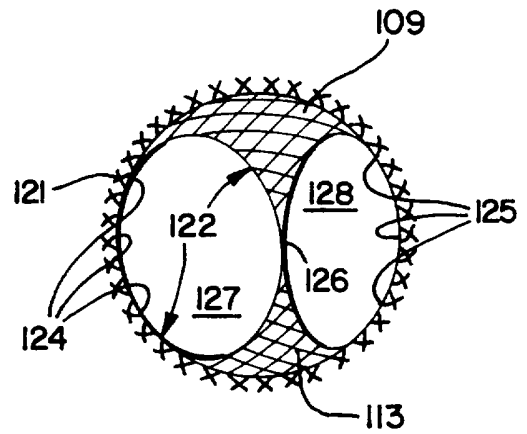
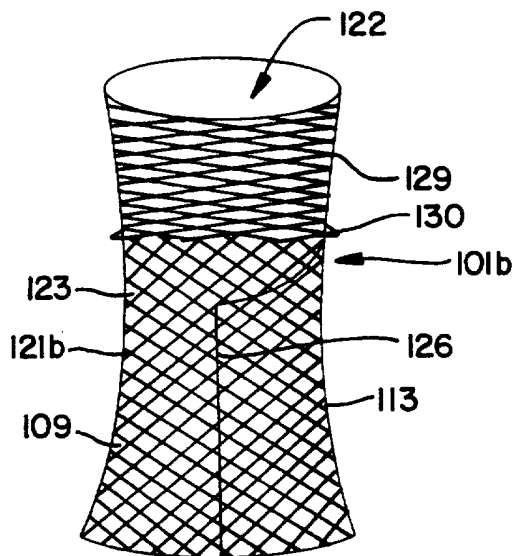

FIG. 28



# INTERNATIONAL SEARCH REPORT

Inter national Application No  
PCT/US 96/17379

A. CLASSIFICATION OF SUBJECT MATTER  
IPC 6 A61F2/06

According to International Patent Classification (IPC) or to both national classification and IPC

B. FIELDS SEARCHED

Minimum documentation searched (classification system followed by classification symbols)  
IPC 6 A61F

Documentation searched other than minimum documentation to the extent that such documents are included in the fields searched

Electronic data base consulted during the international search (name of data base and, where practical, search terms used)

C. DOCUMENTS CONSIDERED TO BE RELEVANT

Category *	Citation of document, with indication, where appropriate, of the relevant passages	Relevant to claim No.
P,X	EP 0 686 379 A (CARDIOVASCULAR CONCEPTS, INC.) 13 December 1995  see column 12, line 43 - column 13, line 11 see column 14, line 3 - line 36	1-3,5,6, 8-10,12, 18,21
A	see figures 5,7-12 ---	26
A	EP 0 551 179 A (EXPANDABLE GRAFTS PARTNERSHIP) 14 July 1993 see column 9, line 3 - column 16, line 53; figures ---	1,26
A	WO 95 13033 A (LAZARUS) 18 May 1995 -----	

Further documents are listed in the continuation of box C.

Patent family members are listed in annex.

\* Special categories of cited documents :

- \*A\* document defining the general state of the art which is not considered to be of particular relevance
- \*E\* earlier document but published on or after the international filing date
- \*L\* document which may throw doubts on priority claim(s) or which is cited to establish the publication date of another citation or other special reason (as specified)
- \*O\* document referring to an oral disclosure, use, exhibition or other means
- \*P\* document published prior to the international filing date but later than the priority date claimed

- \*T\* later document published after the international filing date or priority date and not in conflict with the application but cited to understand the principle or theory underlying the invention
- \*X\* document of particular relevance; the claimed invention cannot be considered novel or cannot be considered to involve an inventive step when the document is taken alone
- \*Y\* document of particular relevance; the claimed invention cannot be considered to involve an inventive step when the document is combined with one or more other such documents, such combination being obvious to a person skilled in the art.
- \*&\* document member of the same patent family

Date of the actual completion of the international search

12 March 1997

Date of mailing of the international search report

24. 03. 97

Name and mailing address of the ISA  
European Patent Office, P.B. 5818 Patentlaan 2  
NL - 2280 HV Rijswijk  
Tel. ( + 31-70) 340-2040, Tx. 31 651 epo nl,  
Fax ( + 31-70) 340-3016

Authorized officer  
  
Smith, C

# INTERNATIONAL SEARCH REPORT

International application No.

PCT/US 96/ 17379

## Box I Observations where certain claims were found unsearchable (Continuation of item 1 of first sheet)

This International Search Report has not been established in respect of certain claims under Article 17(2)(a) for the following reasons:

1.  Claims Nos.: 27-29  
because they relate to subject matter not required to be searched by this Authority, namely:  
PCT Rule 39.1 (iv)
2.  Claims Nos.:  
because they relate to parts of the International Application that do not comply with the prescribed requirements to such an extent that no meaningful International Search can be carried out, specifically:
3.  Claims Nos.:  
because they are dependent claims and are not drafted in accordance with the second and third sentences of Rule 6.4(a).

## Box II Observations where unity of invention is lacking (Continuation of item 2 of first sheet)

This International Searching Authority found multiple inventions in this international application, as follows:

1.  As all required additional search fees were timely paid by the applicant, this International Search Report covers all searchable claims.
2.  As all searchable claims could be searched without effort justifying an additional fee, this Authority did not invite payment of any additional fee.
3.  As only some of the required additional search fees were timely paid by the applicant, this International Search Report covers only those claims for which fees were paid, specifically claims Nos.:
4.  No required additional search fees were timely paid by the applicant. Consequently, this International Search Report is restricted to the invention first mentioned in the claims; it is covered by claims Nos.:

Remark on Protest

- The additional search fees were accompanied by the applicant's protest.
- No protest accompanied the payment of additional search fees.



# INTERNATIONAL SEARCH REPORT

Information on patent family members

International Application No

PCT/US 96/17379

Patent document cited in search report	Publication date	Patent family member(s)	Publication date
EP 686379 A	13-12-95	JP 8052165 A	27-02-96
-----			
EP 551179 A	14-07-93	US 5316023 A	31-05-94
		AU 658253 B	06-04-95
		AU 3108793 A	29-07-93
		BR 9300062 A	13-07-93
		CA 2085918 A	09-07-93
		EP 0667132 A	16-08-95
		JP 5344989 A	27-12-93
		US 5571170 A	05-11-96
		ZA 9210122 A	03-08-93
-----			
WO 9513033 A	18-05-95	AU 1091095 A	29-05-95
-----			