

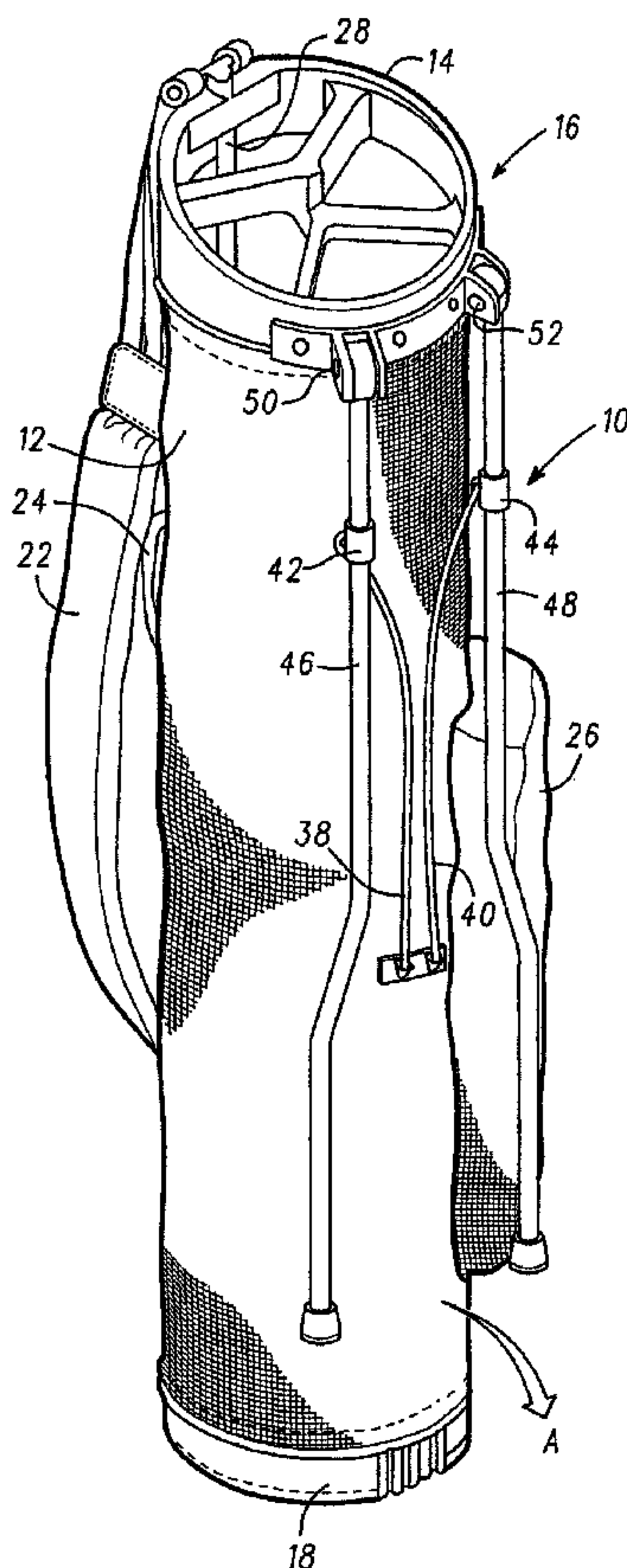

(22) Date de dépôt/Filing Date: 2008/01/04
 (41) Mise à la disp. pub./Open to Public Insp.: 2008/07/12
 (45) Date de délivrance/Issue Date: 2011/03/15
 (30) Priorités/Priorities: 2007/01/12 (US60/884,670);
 2007/08/31 (US11/848,920)

(51) Cl.Int./Int.Cl. *A63B 55/00* (2006.01),
A63B 55/10 (2006.01)
 (72) Inventeurs/Inventors:
 QUARTARONE, FRANK A., III, US;
 MCGUIRE, BRIAN J., US
 (73) Propriétaire/Owner:
 KARSTEN MANUFACTURING CORPORATION, US
 (74) Agent: SMART & BIGGAR

(54) Titre : PIEDS DE SUPPORT POUR SAC DE GOLF
 (54) Title: GOLF BAG STAND



(57) Abrégé/Abstract:

A golf bag has an extensible stand which incorporates legs having a compound bend. The legs provide increased stability when deployed, without increasing the splay angle of the leg pivots. The compound bend in the legs also permits the legs to fold compactly against the golf bag body.

ABSTRACT OF THE DISCLOSURE

A golf bag has an extensible stand which incorporates legs having a compound bend. The legs provide increased stability when deployed, without increasing the splay angle of the leg pivots. The compound bend in the legs also permits the legs to fold compactly against
5 the golf bag body.

68319-230

GOLF BAG STAND

5

BACKGROUND OF THE INVENTION

This invention relates to golf equipment and, in particular, to golf bags with stands.

Golf bags with stands are well known in the art. One popular golf bag with a stand is
10 disclosed in U.S. Patent No. 4,834,235 to Solheim et al. The golf bag disclosed in the Solheim
patent comprises a lightweight fabric body with rigid members at the top and bottom ends. The
rigid members are connected by a rigid spine that extends longitudinally of the body. Because
the spine supports only one side of the body, the diametrically opposed side of the body remains
at least partially collapsible. It is this characteristic that is employed to operate the golf bag stand
15 which is mounted on the partially collapsible side of the body and includes a pair of legs. The
upper ends of the legs are pivotally attached to the rigid member at the top end of the body. An
actuator rod of generally U-shaped configuration is attached to the rigid member at the bottom
end of the body so that the free ends of the actuator rod may be attached to the legs at points
between the upper and lower ends of the legs.

20 Whenever the golf bag is in its normal position, *i.e.*, in the form of a right circular
cylinder, such as when being carried, the distance between the top and bottom ends of the body
will be at a maximum. This causes the legs to be retracted and held firmly against the side of the

68319-230

body so that the legs do not interfere with any normal activities of the golfer carrying the golf bag.

When the golfer sets the golf bag down, the simple and natural movement of resting the golf bag on its bottom end and leaning it over slightly automatically moves the legs of the stand
5 into an extended position as the partially collapsible side of the body collapses. The pivot axes of the legs are approximately tangent to the throat of the golf bag. Accordingly, as the legs deploy they splay outward to provide a more stable tripod than could be accomplished if the pivot axes were parallel. Increasing the separation of the pivots and therefore the splay angle of the legs would increase the stability, however, would reduce the mechanical advantage of the
10 actuator. The longer legs required by an increased splay angle would also potentially extend beyond the bottom of the bag and interfere with the automatic deployment mechanism. Accordingly, it would be advantageous to provide a golf bag with an automatically extensible bag stand having a wider track in its deployed condition without increasing the pivot splay angle or substantially increasing the length of the retracted legs.

15

SUMMARY OF THE INVENTION

The present invention comprises a golf bag with an extensible stand. According to an illustrative embodiment of the invention, the golf bag comprises a generally tubular body and an extensible stand mounted on the body. The extensible stand incorporates legs having a compound bend that provides increased stability when they are deployed, without increasing the
20 splay angle of the leg pivots. The compound bend also permits the legs to fold around the side of the body thereby enabling the legs to fold more compactly than prior art golf bag stands.

68319-230

An aspect of the present invention relates to a golf bag comprising: a body having a generally tubular shape with a top end and a bottom end; and an automatically extensible stand mounted to said body, said automatically extensible stand comprising first and second legs; said first and second legs each having an upper segment, an intermediate segment and a lower segment; said upper segments each having an upper end pivotally mounted to said body proximal said top end and having a first longitudinal axis; said lower segments each having a second longitudinal axis, said second longitudinal axis being substantially parallel to and radially offset outward from said first longitudinal axis; said intermediate segments each forming a rigid connection between said upper segment and said lower segment; said first leg being pivotally mounted to said body by a first hinge defining a first rotational axis and a first rotational plane; said second leg being pivotally mounted to said body by a second hinge defining a second rotational axis and a second rotational plane, said first and second rotational planes being non-parallel; said automatically extensible stand further comprising an actuator rod for moving said first and second legs from a retracted position to a deployed position; said actuator rod having a lower end coupled to the bottom end of said body, a first upper end coupled to an intermediate portion of said first leg, and a second upper end coupled to an intermediate portion of said second leg, whereby said actuator operates to move said first and second legs from the retracted position to the deployed position as said body is tilted from a vertical position to a leaning position.

Another aspect of the present invention relates to a golf bag comprising: a body having a generally tubular shape with a top end and a bottom end said body comprising a flexible fabric sleeve with a generally rigid spine extending along one side of said body between said top end and said bottom end and a partially collapsible side opposite said rigid spine; an automatically extensible stand mounted to said body, said automatically extensible stand comprising first and second legs pivotally attached proximal the top end of said body, each of said first and second legs comprising an elongated substantially Z-shaped member having an upper segment and a lower segment joined together by an intermediate segment such that a longitudinal axis of said upper segment of

68319-230

each of said first and second legs is offset toward said body from a longitudinal axis of a corresponding one of said lower segments of each of said first and second legs, with said upper and lower segments of each of said first and second legs lying in a common plane; said first leg being pivotally mounted to said body
5 by a first hinge defining a first rotational axis and a first rotational plane; said second leg being pivotally mounted to said body by a second hinge defining a second rotational axis and a second rotational plane, said first and second rotational planes being nonparallel; said automatically extensible stand further comprising an actuator rod having a lower end coupled to said bottom end of said
10 body, a first upper end coupled to an intermediate portion of said first leg and a second upper end coupled to an intermediate portion of said second leg, whereby said actuator operates to deploy said first and second legs as said body is tilted from a vertical position to a leaning position.

A further aspect of the present invention relates to a golf bag
15 comprising: a body having a top end and a bottom end; an extensible stand mounted to said body, said extensible stand comprising first and second legs movable from a retracted position to a deployed position; said first and second legs each having an upper segment, an intermediate segment and a lower segment; said upper segment having an upper end pivotally mounted to said body
20 proximal said top end and having a first longitudinal axis; said lower segment having a second longitudinal axis, said lower segment being radially offset outward from said first segment; said intermediate segment forming a rigid connection between said upper segment and said lower segment; an actuator rod for moving said first and second legs from a retracted position to a deployed
25 position as said body is tilted from a vertical position to a leaning position, said actuator rod comprising a lower end coupled to said bottom end of said body, a first upper end coupled to an intermediate portion of said first leg and a second upper end coupled to an intermediate portion of said second leg; wherein the upper segments of said first and second legs are substantially parallel to each
30 other in the retracted position but are not parallel to each other in the deployed position.

DESCRIPTION OF THE DRAWINGS

FIG. 1 is a perspective view of a golf bag incorporating features of the present invention;

5 FIG. 2 is a partially diagrammatic view showing the golf bag of FIG. 1 with its stand in a retracted position;

FIG. 3 is a partially diagrammatic view showing the bag of FIG. 1 with its stand in a deployed position; and

10 FIG. 4 is a perspective view of a leg member of the stand incorporating features of the present invention.

DESCRIPTION

With reference to FIGS. 1-3, golf bag 10 comprises a generally tubular body 12 that may be formed of nylon or other lightweight fabric. A ring-shaped member such as throat 14 is stitched or otherwise mounted to the top end 16 of body 12. Throat 14 is designed to segregate golf clubs into predetermined groups, with golf clubs being inserted into and removed from the bag through the throat 14. A rigid bottom 18 is similarly mounted to the bottom end of body 12. Both throat 14 and bottom 18 are preferably molded or otherwise formed of a suitable synthetic resin in a manner well known in the art. Golf bag 10 may also include various other features normally associated with golf bags such as a shoulder strap 22, handle 24 and an accessory pocket 26. A generally rigid spine 28 interconnects throat 14 and

15
20

bottom 18 to maintain throat 14 and bottom 18 in a spaced-apart relationship. Spine 28 may be made of wood, fiberglass or other suitable rigid lightweight material. Lower end of spine 28 is hingedly attached to bottom 18 by means of a length of fabric or other flexible material forming a fabric hinge which permits bottom 18 to pivot relative to spine 28. As can be
5 determined from the foregoing, because spine 28 extends along only one side of golf bag 10, the side of the body 12 diametrically opposite spine 28 is partially collapsible. Therefore, when placed upright resting on bottom 18, golf bag 10 will tend to collapse toward this collapsible side as indicated by arrow "A" as shown in FIG. 1.

Golf bag 10 further includes an automatically extensible stand with a U-shaped
10 actuator rod 34, the lower end 36 of which is attached to a bearing (not shown) formed in bottom 18. Actuator rod 34 has two upward extending arms 38 and 40. The upper ends of arms 38 and 40 are pivotally attached to collars 42 and 44 formed on legs 46 and 48. Legs 46 and 48 are themselves pivotally attached to hinges or bearings 50 and 52 formed on throat 18.

With additional reference to FIG. 4, leg 46 comprises an upper segment 54, on which
15 the collar 42 is mounted, and a lower segment 56. Upper segment 54 and lower segment 56 have longitudinal axes 58 and 60, respectively, that are parallel and lie in a plane 62 that also contains the rotational axis 64 of bearing 50. Upper segment 54 and lower segment 56 are rigidly connected by a curvilinear intermediate segment 66 having a longitudinal axis 68 also lying in plane 62. Since leg 48 is of substantially identical construction as leg 46, it will not
20 be discussed in detail.

When golf bag 10 is in a normal position as shown in FIG. 2, such as when it is being carried or held in an upright position, body 12 generally will be cylindrical in shape. In such a state, the action of bottom 18 acting on legs 46 and 48 through actuator rod 34 will cause legs

46 and 48 to fold against the side of body 12 in a retracted position and thus be held out of the way. As shown in FIGS. 1 and 2, because the bend in the legs 46, 48 is coplanar with the plane containing the pivot axes 50 and 52, the resulting substantially Z-shaped legs 46, 48 fold partially around the body 12 and out of the way. When golf bag 10 is placed on the ground and tilted slightly forward, the collapsible portion of body 12 collapses and the actuator rod 34 moves the legs 46, 48 into a deployed position.

Bearings 50 and 52 are substantially tangent to throat 14 and, therefore, are non-parallel. Accordingly, as legs 46 and 48 are deployed, they splay outward by a predetermined amount determined by the angle between the axis of bearing 50 and the axis of bearing 52. If legs 46 and 48 were straight, the splay angle would produce a predetermined width d_1 as shown in FIG. 3. Because the lower segments 56 and 56a are offset radially outward from upper segments 54 and 54a relative to the longitudinal axis of body 12, the stance of the legs 46, 48 is increased to a distance d_2 as shown in FIG. 3. This is accomplished without increasing the offset "x" between the line of action of actuator 34 and legs 46 and 48, which would decrease the mechanical advantage of actuator 34 and possibly cause the stand to bind. Instead, because of the unique shape of legs 46 and 48, their stance is increased for additional stability while maintaining the actuator offset distance "x" within acceptable limits.

Although certain illustrative embodiments and methods have been disclosed herein, it will be apparent from the foregoing disclosure to those skilled in the art that variations and modifications of such embodiments and methods may be made without departing from the spirit and scope of the invention. Accordingly, it is intended that the invention should be limited only to extent required by the appended claims and the rules and principals of applicable law.

68319-230

CLAIMS:

1. A golf bag comprising:
- a body having a generally tubular shape with a top end and a bottom end; and
- 5 an automatically extensible stand mounted to said body, said automatically extensible stand comprising first and second legs;
- said first and second legs each having an upper segment, an intermediate segment and a lower segment;
- said upper segments each having an upper end pivotally mounted to
- 10 said body proximal said top end and having a first longitudinal axis;
- said lower segments each having a second longitudinal axis, said second longitudinal axis being substantially parallel to and radially offset outward from said first longitudinal axis;
- said intermediate segments each forming a rigid connection between
- 15 said upper segment and said lower segment;
- said first leg being pivotally mounted to said body by a first hinge defining a first rotational axis and a first rotational plane;
- said second leg being pivotally mounted to said body by a second hinge defining a second rotational axis and a second rotational plane, said first
- 20 and second rotational planes being non-parallel;
- said automatically extensible stand further comprising an actuator rod for moving said first and second legs from a retracted position to a deployed position; said actuator rod having a lower end coupled to the bottom end of said body, a first upper end coupled to an intermediate portion of said first leg, and a
- 25 second upper end coupled to an intermediate portion of said second leg, whereby said actuator operates to move said first and second legs from the retracted

68319-230

position to the deployed position as said body is tilted from a vertical position to a leaning position.

2. The golf bag of claim 1, wherein said upper segment of said first leg is spaced apart from said upper segment of said second leg.

5 3. The golf bag of claim 1, wherein said upper segment of said first leg and said upper segment of said second leg are substantially parallel in the retracted position and are nonparallel in the deployed position.

4. The golf bag of claim 1, wherein:

10 said body comprises a flexible fabric sleeve with a generally rigid spine extending along one side of said body between said top end and said bottom end;

said body further comprises a partially collapsible side opposite said generally rigid spine;

15 said actuator rod comprises a lower end coupled to said bottom end of said body, a first upper end coupled to said upper segment of said first leg and a second upper end coupled to said upper segment of said second leg; and

said actuator rod operates to deploy said first and second legs as said body is tilted from a vertical position to a leaning position.

5. A golf bag comprising:

20 a body having a generally tubular shape with a top end and a bottom end said body comprising a flexible fabric sleeve with a generally rigid spine extending along one side of said body between said top end and said bottom end and a partially collapsible side opposite said rigid spine;

25 an automatically extensible stand mounted to said body, said automatically extensible stand comprising first and second legs pivotally attached proximal the top end of said body, each of said first and second legs comprising an elongated substantially Z-shaped member having an upper segment and a

68319-230

lower segment joined together by an intermediate segment such that a longitudinal axis of said upper segment of each of said first and second legs is offset toward said body from a longitudinal axis of a corresponding one of said lower segments of each of said first and second legs, with said upper and lower
5 segments of each of said first and second legs lying in a common plane;

said first leg being pivotally mounted to said body by a first hinge defining a first rotational axis and a first rotational plane;

said second leg being pivotally mounted to said body by a second hinge defining a second rotational axis and a second rotational plane, said first
10 and second rotational planes being nonparallel;

said automatically extensible stand further comprising an actuator rod having a lower end coupled to said bottom end of said body, a first upper end coupled to an intermediate portion of said first leg and a second upper end coupled to an intermediate portion of said second leg, whereby said actuator
15 operates to deploy said first and second legs as said body is tilted from a vertical position to a leaning position.

6. The golf bag of claim 5, wherein said upper segment of said first leg is spaced apart from said upper segment of said second leg.

7. The golf bag of claim 5, wherein the longitudinal axes of the upper
20 segments of each of said first and second legs are substantially parallel in the retracted position and are nonparallel in the deployed condition.

8. A golf bag comprising:

a body having a top end and a bottom end;

an extensible stand mounted to said body, said extensible stand
25 comprising first and second legs movable from a retracted position to a deployed position;

68319-230

said first and second legs each having an upper segment, an intermediate segment and a lower segment;

said upper segment having an upper end pivotally mounted to said body proximal said top end and having a first longitudinal axis;

5 said lower segment having a second longitudinal axis, said lower segment being radially offset outward from said first segment;

said intermediate segment forming a rigid connection between said upper segment and said lower segment;

10 an actuator rod for moving said first and second legs from a retracted position to a deployed position as said body is tilted from a vertical position to a leaning position, said actuator rod comprising a lower end coupled to said bottom end of said body, a first upper end coupled to an intermediate portion of said first leg and a second upper end coupled to an intermediate portion of said second leg;

15 wherein the upper segments of said first and second legs are substantially parallel to each other in the retracted position but are not parallel to each other in the deployed position.

9. The golf bag of claim 8, wherein said body has a generally tubular shape.

20 10. The golf bag of claim 8, wherein said lower segments of said first and second legs are not parallel to each other in said retracted and deployed positions.

11. The golf bag of claim 8, wherein said actuator rod is connected to collars mounted on said upper segments of said first and second legs.

25 12. The golf bag of claim 8, wherein said first and second legs are each substantially Z-shaped.

13. The golf bag of claim 8, wherein:

68319-230

said body comprises a flexible fabric sleeve with a generally rigid spine extending along one side of said body between said top end and said bottom end;

5 said body further comprising a partially collapsible side opposite said rigid spine.

14. The golf bag of claim 8, wherein:

said upper segments are pivotally mounted to a ring-shaped member attached to the top end of said body.

15. The golf bag of claim 8, wherein:

10 said first and second legs each comprise a single unitary tubular member.

16. The golf bag of claim 1, wherein:

said body has a throat comprising a ring-shaped member attached to the top end of said body; and

15 said first and second rotational axes are tangent to said throat.

17. The golf bag of claim 16, wherein:

said throat includes a plurality of dividers for segregating a plurality of golf clubs into predetermined groups.

18. The golf bag of claim 1, wherein:

20 said actuator rod comprises a unitary U-shaped rod member.

19. The golf bag of claim 8, wherein:

said actuator rod comprises a unitary U-shaped rod member.

20. The golf bag of claim 8, wherein

68319-230

said body has a throat comprising a ring-shaped member attached to the top end of said body, said throat including a plurality of dividers for segregating a plurality of golf clubs into predetermined groups.

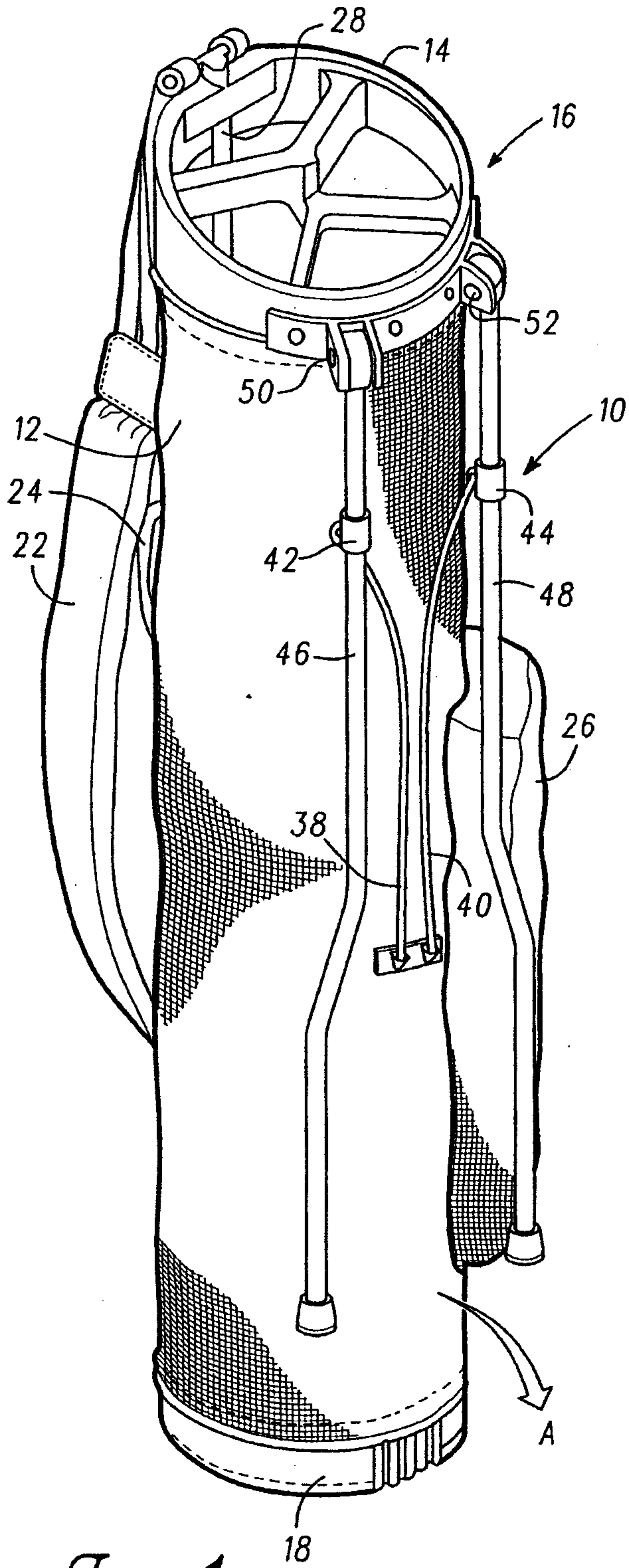

Fig. 1

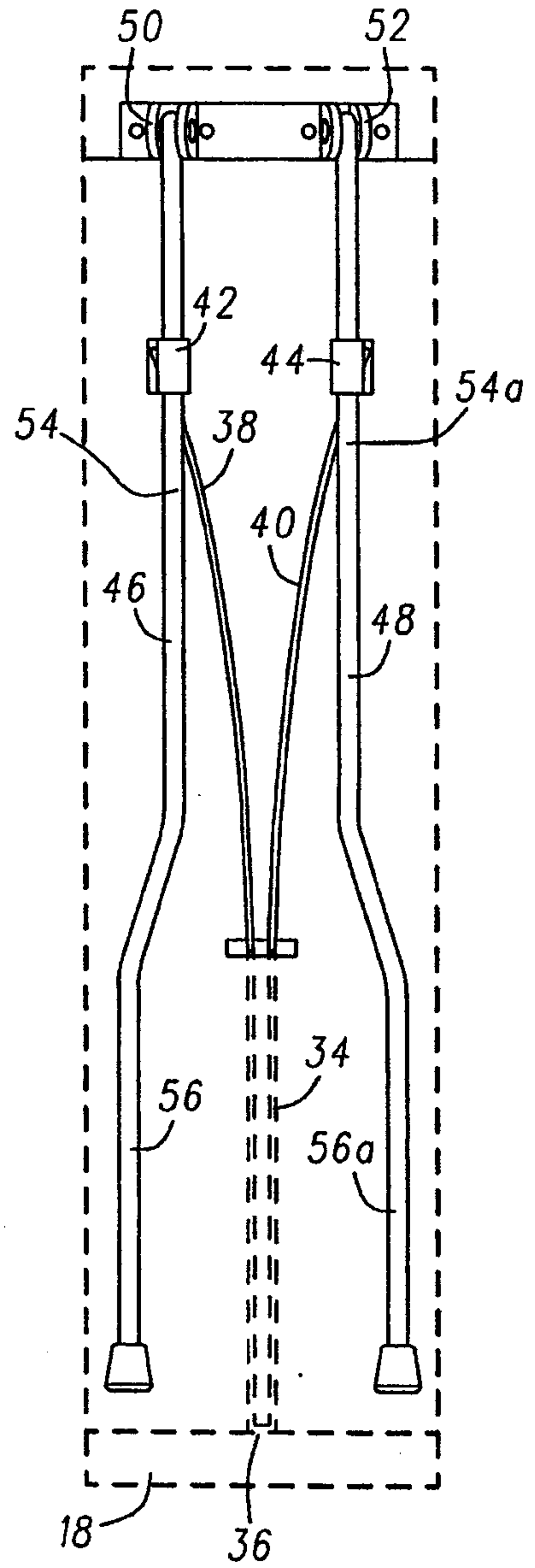

Fig. 2

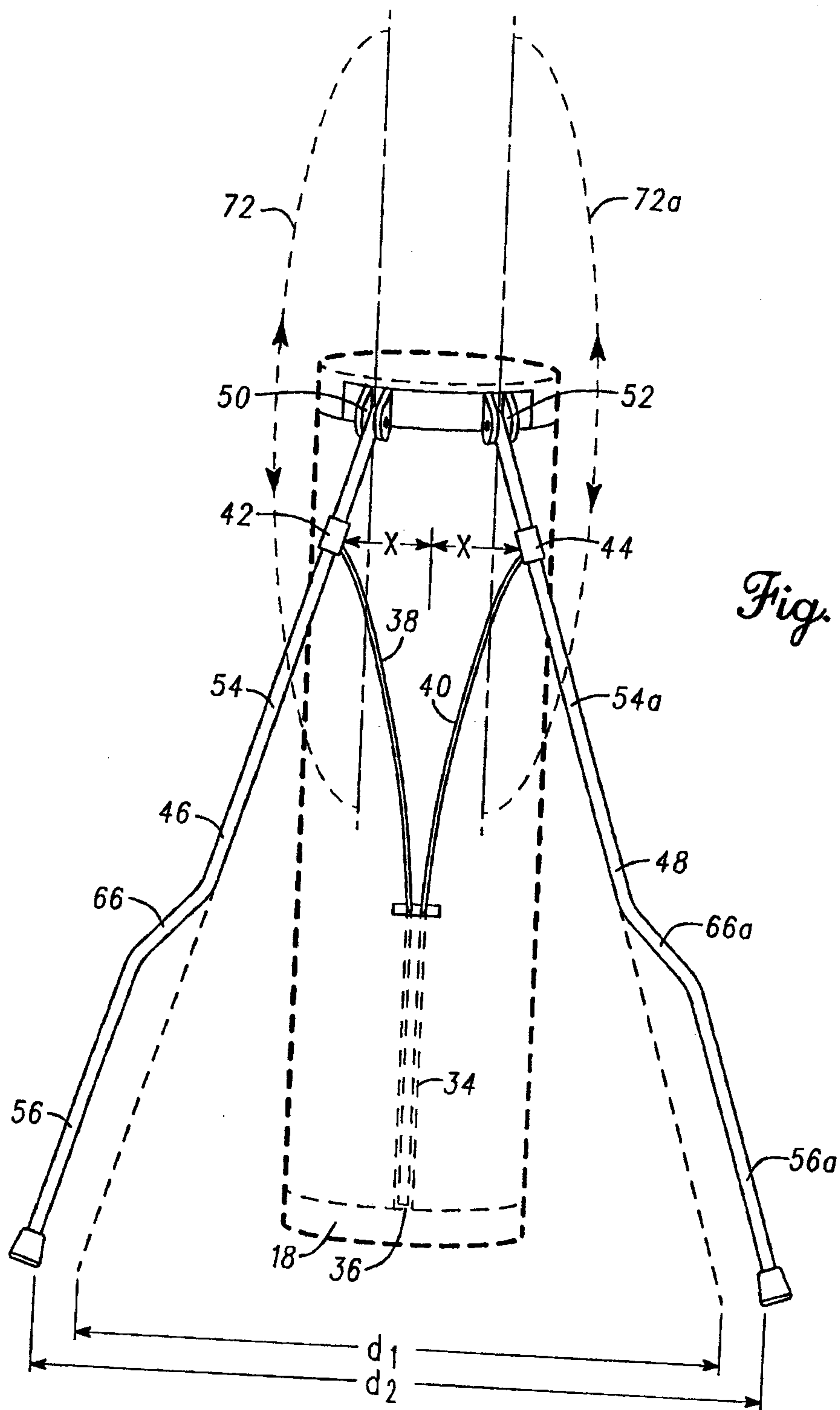

Fig. 3

