

Feb. 7, 1928.

1,658,728

C. H. LYON

SMOKE PIPE

Filed Jan. 6, 1926

Fig. 1

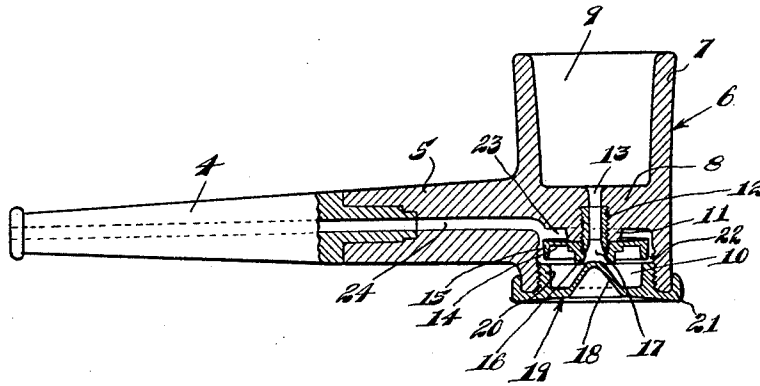

Fig. 2

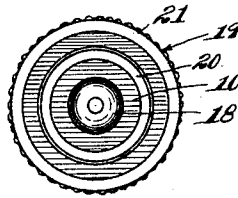
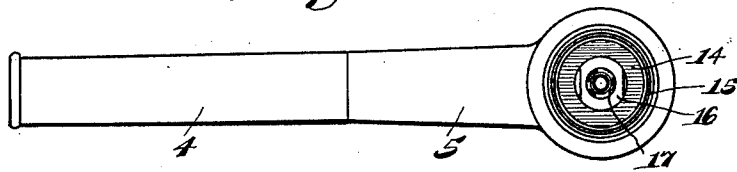

Fig. 3

Witnesses:

C. E. Wessels.

[Signature]

Inventor:

Charles H. Lyon,

By *[Signature]*
his Attorney.

UNITED STATES PATENT OFFICE.

CHARLES H. LYON, OF CHICAGO, ILLINOIS.

SMOKE PIPE.

Application filed January 6, 1926. Serial No. 79,512.

My invention relates to a smoking pipe, and the same has for its paramount object the provision of an improved pipe construction of this character which will embody certain desired features of simplicity, efficiency and convenience and which will be economical in manufacture.

Another object is to provide a smoking pipe having a dehydrating chamber arranged below the bottom of the bowl and through which the smoke must pass on its way to the stem; to provide a removable cup-like closure for the dehydrating chamber for receiving the condensation from the smoke; and further to form the closure with a surface condenser over which the smoke is diffused prior to being drawn into the stem.

Other objects will appear hereinafter.

The invention consists in the combinations and arrangements of parts hereinafter described and claimed.

The invention will be best understood by reference to the accompanying drawing forming a part of this specification, and in which,

Fig. 1 represents a partial longitudinal sectional view through a smoking pipe made in accordance with the present invention;

Fig. 2 represents an underneath plan view with the closure for the dehydrating chamber removed; and,

Fig. 3 represents a top plan view of the closure for the dehydrating chamber.

In its preferred form of construction, as illustrated in the accompanying drawing, the smoking pipe of the present invention comprises a mouth piece 4 of any convenient construction, a stem 5 and a bowl 6, the bowl wall 7 being of cylindrical form and there being a main relatively thick bottom 8 intermediate the height of the bowl wall 7 to produce a tobacco-burning cavity 9 and a dehydrating chamber 10. On its underside the main bottom 8 is preferably formed with a boss or thickened region 11. Threaded upwardly through the boss or thickened region 11 and into the main bottom 8 is a hollow stud 12 into which the smoke and vapors of combustion are drawn through a passageway 13 leading from the cavity 9.

The hollow stud 12 protrudes for a distance below the boss 11 and there is threaded upon the protruding end thereof a circular smoke diffuser 14 which is preferably formed with a circumferential depending flange 15 and a central annular flange 16,

the said smoke diffuser, as herein shown, also having within the annular flange 16 a central opening 17 in communication with the interior of the hollow stud, so that the smoke and vapors of combustion can be drawn downwardly through the passageway 13, hollow stud 12 and opening 17 into the dehydrating chamber 10.

In accordance with an important feature of the present invention, the annular flange 16 directs the smoke and vapors of combustion upon a surface condenser in the form of an upward deformation 18, preferably cone-shaped as shown, provided on the auxiliary bottom 19 which serves as a closure for the dehydrating chamber 10. Said auxiliary bottom 19 is designed to receive the condensations from the smoke and vapors of combustion, being provided for this purpose with an upwardly projecting flange 20 which is exteriorly threaded to be removably engaged with the interior threads provided for the purpose on the lower end of the cylindrical wall 7. Preferably and as shown, the closure 19 is also made with a second flange 21 which is adapted to engage over the exterior of the cylindrical wall 7.

It will be evident that the closure 19, being an outside member, is constantly cooled by the outside atmosphere; and it is to be observed that the upward deformation 18 is preferably made relatively thin as shown, so as to serve as a surface condenser for the smoke and vapors of combustion deflected thereon by the flange 17. The moisture deposited on the upward deformation 18 collects in the hollow between said deformation 18 and the flange 20. Obviously, the condensations collected by the closure 19 may be readily discarded upon unthreading the closure from the bowl. The smoke diffuser 14 with its flanges 15 and 16 directs the smoke against closure 19 condensing the moisture thereby, so that the smoke drawn through the relatively narrow circumferential passage 22 and the top passage 23 is quite dry and is entirely free of any solid substances. It will be observed that the boss 11 serves as a spacer for the smoke diffuser so as to produce the upper space 23 with which the passageway 24 of the stem 5 is in communication. Under this construction the smoke being dehydrated and being freed of all solid substances prior to reaching the upper space or chamber 23, the passageway 24 of the stem is always kept clean and dry.

While I have illustrated and described the preferred form of construction for carrying my invention into effect, this is capable of variation and modification without departing from the spirit of the invention. I, therefore, do not wish to be limited to the precise details of construction set forth, but desire to avail myself of such variations and modifications as come within the scope of the appended claims.

Having described my invention, what I claim as new and desire to secure by Letters Patent is:

1. In a tobacco pipe having a bowl and a stem; a dehydrating chamber interposed in the smoke passage between said bowl and said stem, in which is positioned a surface condenser protruding into said chamber, and a deflector adapted to diffuse the smoke from said bowl over said condenser.

2. In a tobacco pipe having a bowl and a stem; a dehydrating chamber formed in said bowl separate from but in communication with the tobacco chamber and said stem; a cone shaped surface condenser extending into

said dehydrating chamber; a flanged deflector above said condenser adapted to direct the smoke from said tobacco chamber on to said condenser prior to its passage through said stem.

3. In a tobacco pipe having a bowl and stem; a tobacco chamber at the top of said bowl; a dehydrating chamber within said bowl below said tobacco chamber, the floor of which is removable; a channel from said tobacco chamber into said dehydrating chamber; flanges affixed to the lower end of said channel to cause the smoke from said tobacco chamber to eddy about in said dehydrating chamber; a cone shaped surface condenser integral with said removable floor, protruding into said dehydrating chamber and positioned below said channel and flanges; and a passage from the top of said dehydrating chamber above said flanges into said stem.

In testimony whereof I have signed my name to this specification.

CHARLES H. LYON.