

(19)
(12)

(KR)
(Y1)

(51) 。 Int. Cl.7
E04D 13/18

(45)
(11)
(24)

2004 08 21
20-0359176
2004 08 06

(21) 20-2004-0012873

(22) 2004 05 10

(73) 1 917-9 41 3108

(72) 27|2-222

(74) :

(54)

(11) , (11) (12) (13) (10) ;
 (11) , (1) (11) (1) (14)
 , (13) 1 (21) 1 (21) (21) (12)
 (15) , 1 (21) 2 (22)
 (30) (1) , 2 (22) (30) (31)

4

1

2

1

3 2 ,
 4 ,
 5 4 ,
 6 ,
 7 ,
 8 .
 * *

1 : 10 :
 11 : 11a :
 12 : 12a :
 13 : 14 :
 15 : 15a :
 16 : 21 : 1
 21a : 22 : 2
 30 : 31 :

(電池板)

(photovoltaic module)
(DC)

(AC)

가

(日射) 가

가

가

(10) ; (11) , (11) (12) (13)
 (14) , (1) (11) (1) (1)
 (12) (13) 1 (21) 1 (21) (21)
 (22) (15) , 1 (21) 2
 (31) (30) (1) (22) (30)

1 8 (10) (11), (12)
 (13) , (11) (12) , (12)
 (13) (12) (15) (12a) , (11) (

14) (12) (15) (11a) (12a) , (11) ((11)가 (11), (12), (13)
 , (11)

(11) (1) (11) (11a) (1)
 (14) (12) (13) 1 (21) 1 , 1 (21) (21) ((15) (15a) 1 (21) (10)

1 (21) (12) (12a) (21a) (15)
 (15a) 1 (21) 2 (22) (格子形)

2 (22) (30) (31) ,
 (30) (10) 1 (21) 2 (22) (1)

(11) , (14) (16)가 (16)
 , (1) (soldering)

(11a) (14) (1) (10) (10) (1) (11)
 , (10) (13) 1 (1) (21) (10) 1 (21) (21a)
) (12) (12a) 1 (21) (15) (21) 1 (21) (10) (30)
 (31) 1 (21) (30) 2 (22) (1)

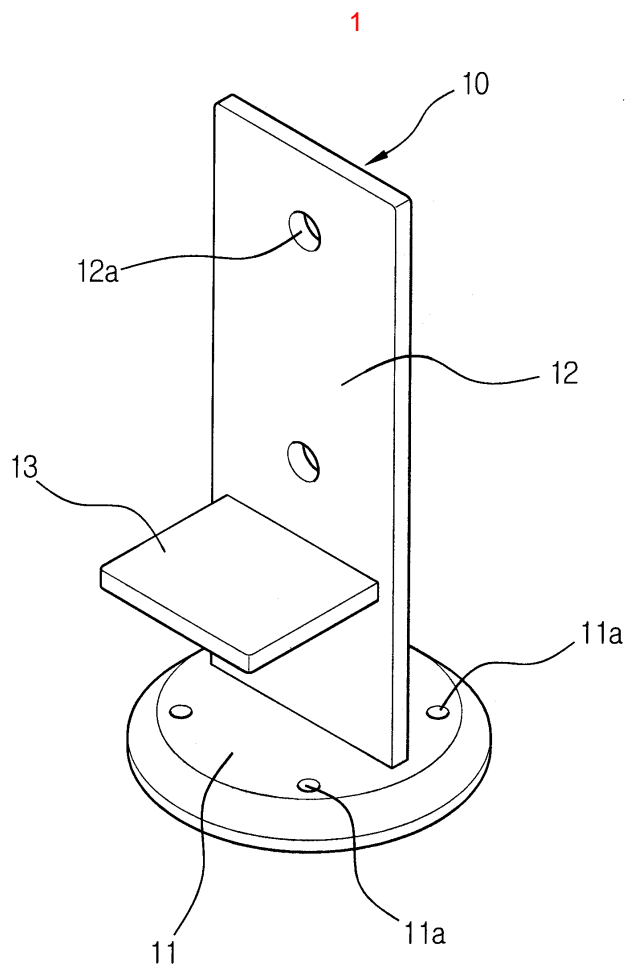

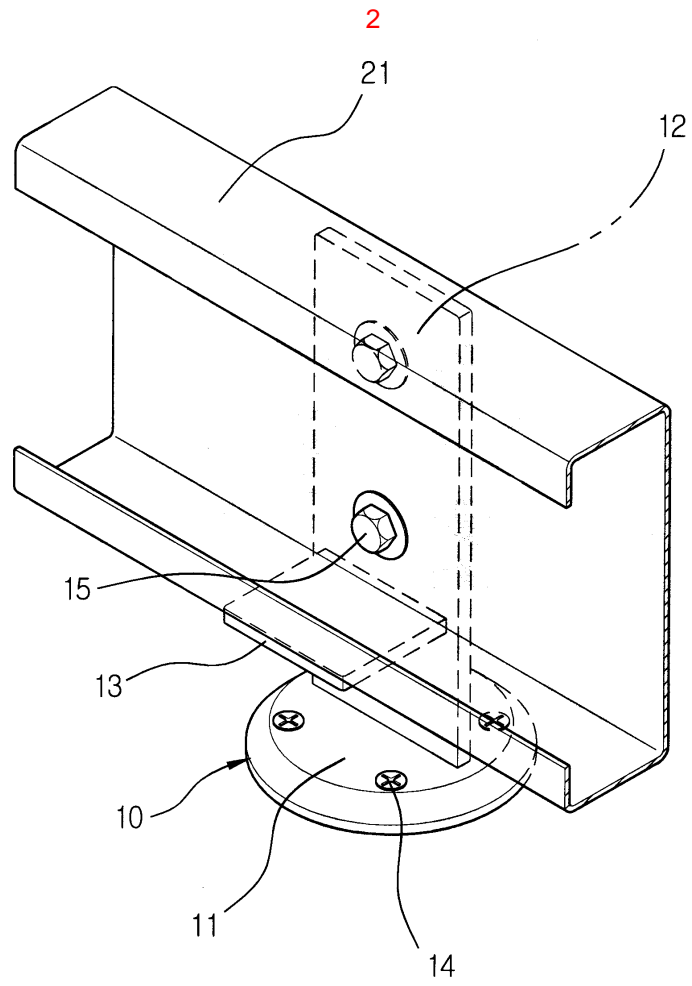

3

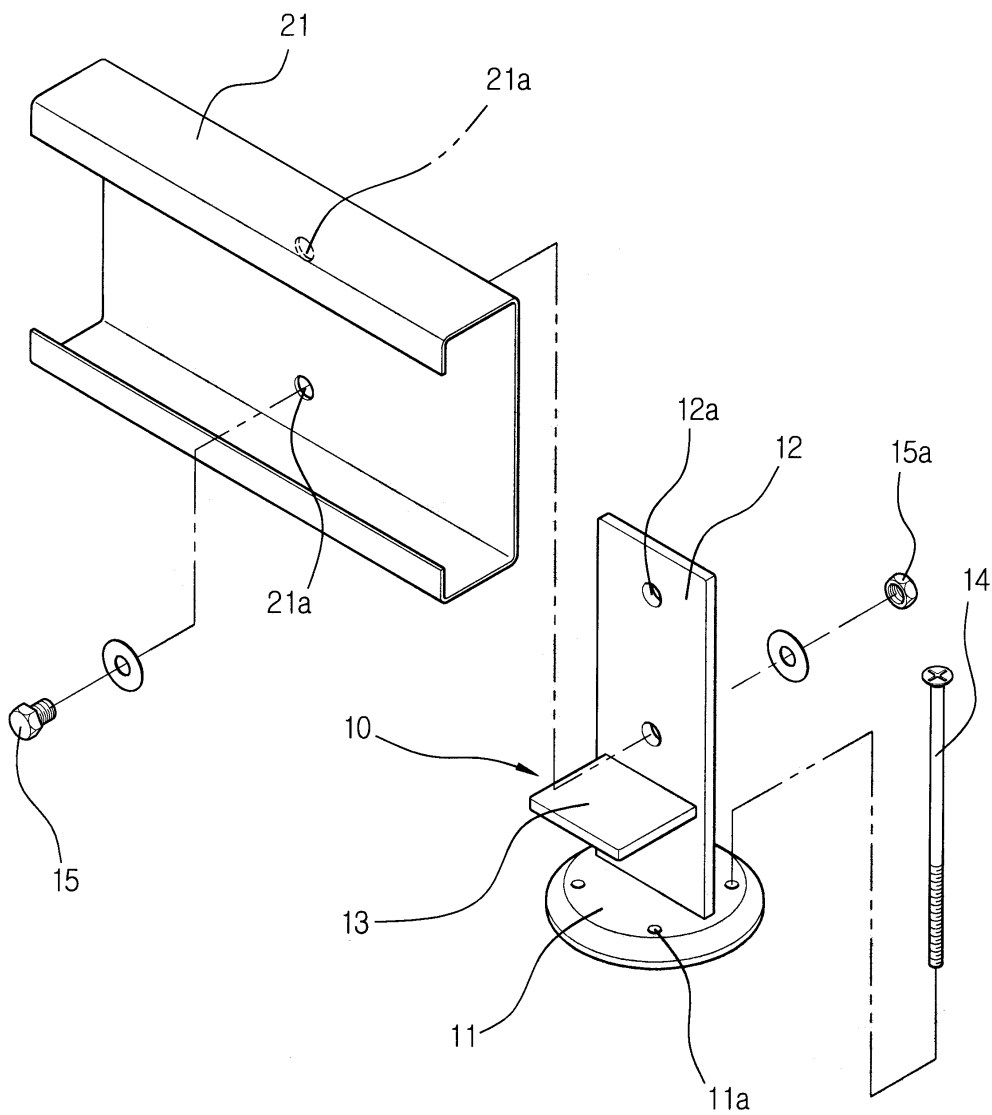

4

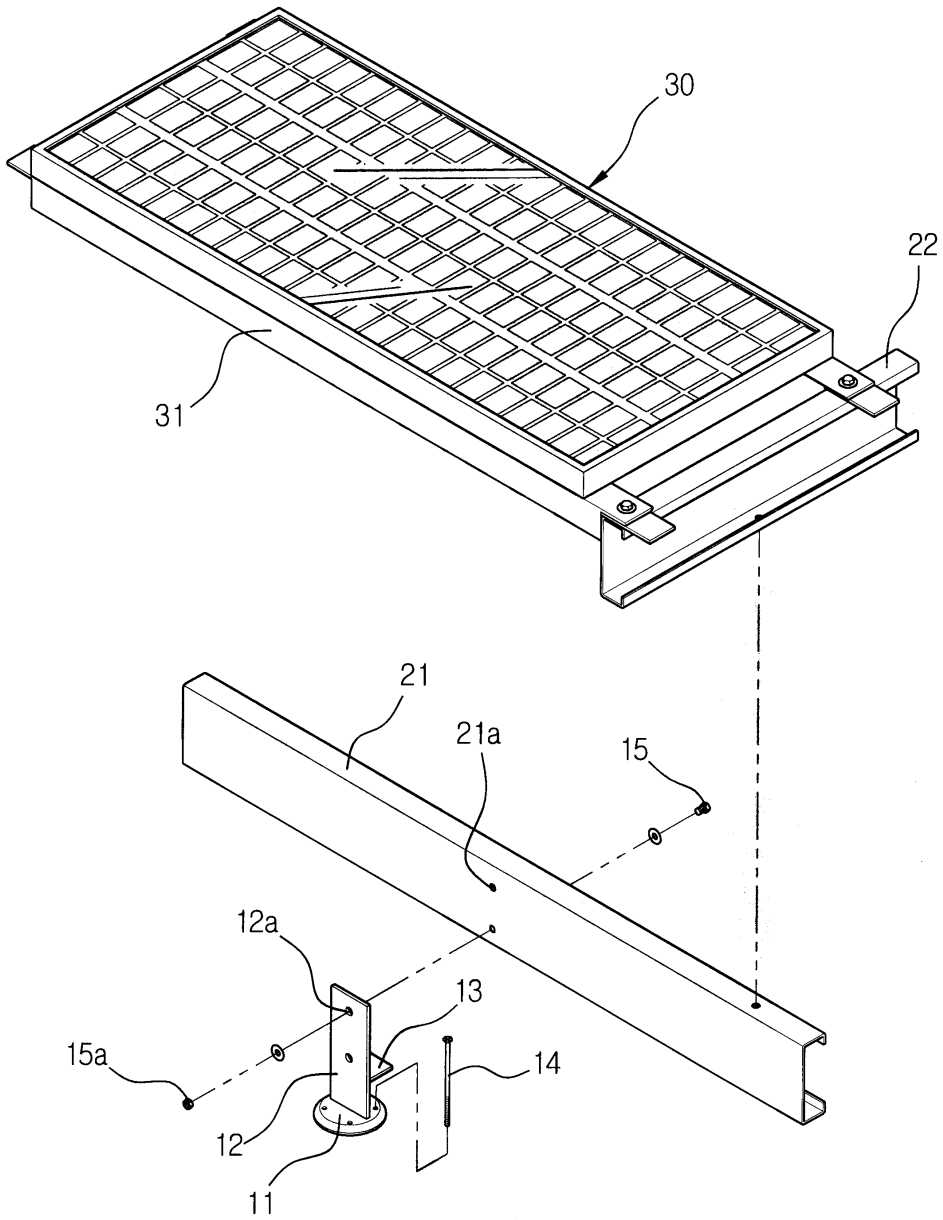

5

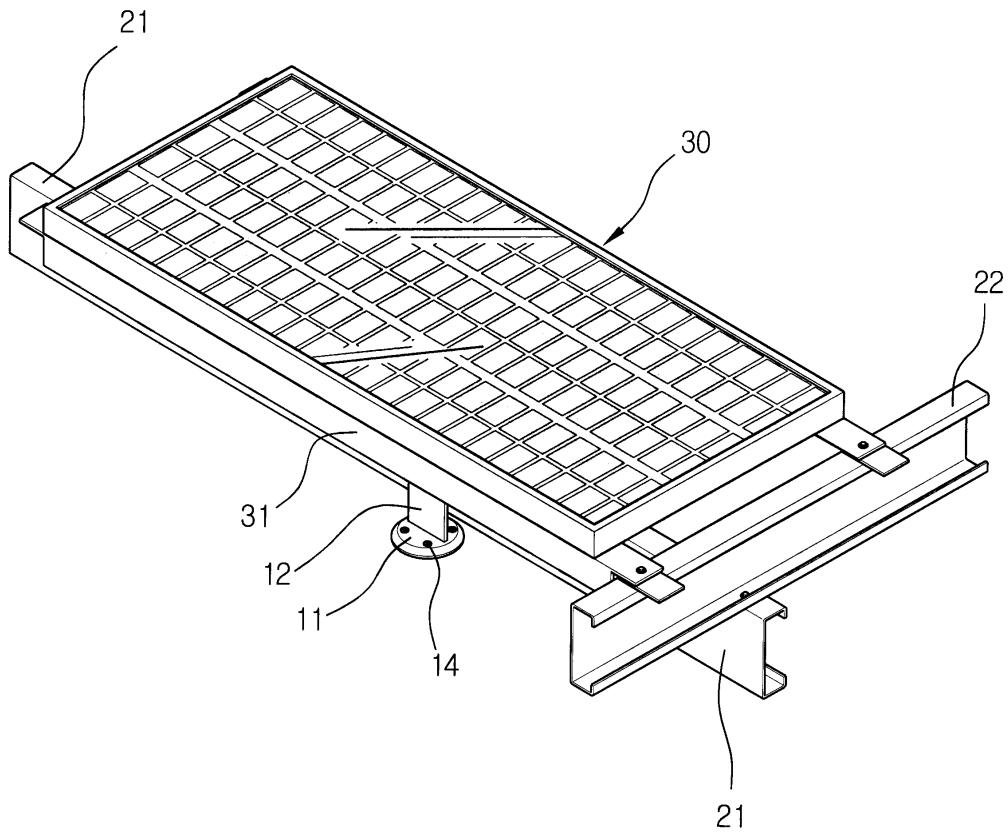

6

