



(51) International Patent Classification:
A61M 16/00 (2006.01)

(21) International Application Number:
PCT/US20 15/044341

(22) International Filing Date:
7 August 2015 (07.08.2015)

(25) Filing Language: English

(26) Publication Language: English

(30) Priority Data:
62/039,759 20 August 2014 (20.08.2014) US
62/078,677 12 November 2014 (12.11.2014) US
62/161,041 13 May 2015 (13.05.2015) US

(71) Applicant: **REVOLUTIONARY MEDICAL DEVICES, INC.** [US/US]; 4090 E. Bujia Primera, Tucson, Arizona 8571 8 (US).

(72) Inventors: **PEDRO, Michael J.**; 185 Ocean Avenue, Apt. 2A, Brooklyn, New York 11225 (US). **CATALDO, Steven H.**; 45 Wall Street, Apt. 302, New York, New York 10005 (US). **REILLY, Thomas M.**; 12240 E. Tanque Verde Rd., Tucson, Arizona 85749-8428 (US). **REDFORD, Ryan G.**; 3300 N. Paseo De Los Rios #9205, Tucson, Arizona 85712 (US). **KRONES, Peter**; 66 Moseman Avenue, Katonah, New York 19536 (US). **KANE, David M.**; 4090 E. Bujia Primera, Tucson, Arizona 8571 8 (US).

(74) Agents: **SOLOWAY, Norman P.** et al; Hayes Soloway P.C., 4640 E. Skyline Drive, Tucson, Arizona 85718 (US).

(81) Designated States (unless otherwise indicated, for every kind of national protection available): AE, AG, AL, AM, AO, AT, AU, AZ, BA, BB, BG, BH, BN, BR, BW, BY, BZ, CA, CH, CL, CN, CO, CR, CU, CZ, DE, DK, DM, DO, DZ, EC, EE, EG, ES, FI, GB, GD, GE, GH, GM, GT, HN, HR, HU, ID, IL, IN, IR, IS, JP, KE, KG, KN, KP, KR, KZ, LA, LC, LK, LR, LS, LU, LY, MA, MD, ME, MG, MK, MN, MW, MX, MY, MZ, NA, NG, NI, NO, NZ, OM, PA, PE, PG, PH, PL, PT, QA, RO, RS, RU, RW, SA, SC, SD, SE, SG, SK, SL, SM, ST, SV, SY, TH, TJ, TM, TN, TR, TT, TZ, UA, UG, US, UZ, VC, VN, ZA, ZM, ZW.

(84) Designated States (unless otherwise indicated, for every kind of regional protection available): ARIPO (BW, GH, GM, KE, LR, LS, MW, MZ, NA, RW, SD, SL, ST, SZ, TZ, UG, ZM, ZW), Eurasian (AM, AZ, BY, KG, KZ, RU, TJ, TM), European (AL, AT, BE, BG, CH, CY, CZ, DE, DK, EE, ES, FI, FR, GB, GR, HR, HU, IE, IS, IT, LT, LU, LV, MC, MK, MT, NL, NO, PL, PT, RO, RS, SE, SI, SK, SM, TR), OAPI (BF, BJ, CF, CG, CI, CM, GA, GN, GQ, GW, KM, ML, MR, NE, SN, TD, TG).

Published:

- with international search report (Art. 21(3))
- before the expiration of the time limit for amending the claims and to be republished in the event of receipt of amendments (Rule 48.2(h))

(54) Title: VENTILATION MASK

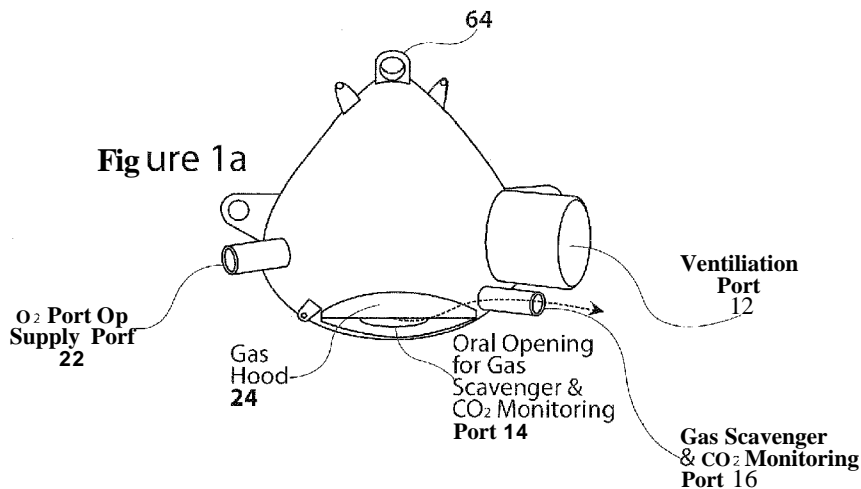

(57) Abstract: Disclosed is a nasal ventilation mask having separate ports to monitor end-tidal CO₂ expulsion integrated into the mask in order to monitor end-tidal CO₂ expelled nasally or orally. Also disclosed is a CPR mask for nose-to-mouth and/or mouth-to-mouth resuscitation, having a body shaped to cover the nose and/or mouth of a victim, said mask including a CO₂ absorber for eliminating at least in part rescuer's exhaled CO₂ delivered to the victim.



VENTILATION MASK

This application claims priority from U.S. Provisional Application Serial No. 62/039,759, filed August 20, 2014 and from U.S. Provisional Application Serial No. 62/078,677, filed November 12, 2014 and from U.S. Provisional Application Serial
5 No. 62/161,041, filed May 13, 2015, the contents of which are incorporated herein by reference.

The present invention relates to improvements in anesthesia masks and ventilation masks.

During surgery a patient usually is placed under anesthesia. The most
10 common delivery system consists of canisters containing anesthesia gases and oxygen, a system of regulating the gas flow and the patient's breathing, and a device ensuring the potency of the patient's airway for breathing, oxygenation and the delivery of the anesthetic gas mixture. A ventilation mask is used to provide oxygen to the patient either during emergency and/or elective airway management, which
15 includes but is not limited to; before a patient is anesthetized for surgery, while the patient is anesthetized, if the patient is sedated during the surgery or procedure, while the patient is recovering from anesthesia, after the patient has recovered from anesthesia, or during any event where a patient requires supplemental oxygen. However, one of the drawbacks of mask ventilation is that it requires constant contact
20 between the provider's hands and the patient's face to hold the mask in place and keep the patient in the sniffing position in order to ensure that oxygen and anesthetic gases do not leak out into the air and that the patient's airway remains patent. If the provider does not maintain the patient in the sniffing position, a dangerous complication known as upper airway obstruction may occur. The reason the provider
25 needs to perform continuous mask holding and maneuvering is the human anatomy and physiology. When muscles of the jaw, tongue and upper airway relax due to sedatives and/or muscle relaxants given to the patient for sedation and/or anesthesia, the upper airway (mouth, pharynx, larynx) may become partially obstructed and possibly completely closed. Wherein, when the jaw of the patient drops and the
30 tongue obstructs the airway resulting in snoring (partial obstruction) or apnea (complete inability for oxygen to pass via the upper airway into the lungs). Another problem exists when a provider fails to administer enough anesthesia or sedation or it

begins to wear off and the patient begins to move. This can cause the patient's airway to obstruct as well since the patient's head and neck position are no longer in the sniffing position. Patient movement during surgery can also be dangerous because it can cause the surgeon to make a mistake, particularly in eye, ear, nose, neck, head, and throat surgery.

Furthermore, situations arise during surgery that require rapid intubation of a patient. Full face masks, i.e. masks covering both the nose and mouth of a patient are problematic in emergency situations since a mask must be removed to uncover the mouth of a patient for intubation. However, removing the mask also removes oxygen support. As will be described below, the present invention in one aspect addresses the aforesaid and other disadvantages of the prior art.

The present invention, in another aspect relates to cardiopulmonary resuscitation (CPR) masks.

Cardiopulmonary resuscitation, commonly known as CPR is an emergency procedure performed in an effort to manually preserve intact brain function until further measures may be taken to restore spontaneous blood circulation and breathing in a person (hereinafter the "subject" or "victim") who is in cardiac arrest. CPR also is indicated in those who are unresponsive with no breathing such as in the case of a drowning victim or victim of electrical shock, or abnormal breathing, for example agonal respiration.

CPR involves chest compressions at least two inches deep and at a rate of at least 100 per minute in an effort to create artificial circulation by manually pumping blood through the heart and thus the body. The rescuer also may provide breaths by either exhaling directly into the subject's mouth, or through a CPR mask into the subject's mouth and/or nose (collectively "mouth-to-mouth resuscitation"), or using a device that pushes air into the subject's lungs through the subject's mouth and/or nose. The process of externally providing ventilation is termed "artificial respiration". Current recommendations place emphasis on high-quality chest compressions over artificial respiration; however, when coupled with high-quality chest compressions, artificial respiration provides potentially the greatest benefit to the patient.

Conventional CPR masks are held in place by hand, by the CPR provider, or may be retained in position by straps that extend behind the head of the subject or victim. While CPR masks may assist in ventilation of a subject or victim who is not breathing, when a rescuer provides mouth-to-mouth and/or nose-to-mouth
5 resuscitation, the air provided contains a significant amount of CO₂ which is lethal. As will be discussed below, the present invention in another aspect addresses the aforesaid and other disadvantages of the prior art.

The present invention in one aspect provides an improved ventilation/anesthesia mask that overcomes the aforesaid and other problems of the
10 prior art. More particularly, there is provided a nasal ventilation/anesthesia mask comprising one or more offset gas openings to allow the provider to have a clear view of the mouth and airway during direct laryngoscopy and intubation, which consists of a ventilation port to supply oxygen and other gases during anesthesia via Non-
15 Invasive Positive Pressure Ventilation (NIPPV) and which is connected to an anesthesia circuit which can measure end-tidal CO₂ from the nose, an oral opening port under the nose for scavenging anesthesia gases and end-tidal CO₂ that are expelled orally from the patient; a gas scavenging/end-tidal CO₂ port connected to a channel inside the mask that is isolated from the nasal cavity, and an oxygen port for
20 supplying post op oxygen. Completing the mask are a plurality of tabs or eyelets, preferably three, or four, for strapping the mask to the patient's head or for tying the mask down to the operating table, e.g., in accordance with the teachings of our co-
pending PCT application PCT/US 14/44934 and on co-pending PCT application PCT/US 15/34277.

In one embodiment of the invention there is provided a nasal ventilation mask
25 having an O₂ port for introducing oxygen into the mask, a ventilation port and a gas monitoring attachment integral to or attached to the ventilation port. In such embodiment, the gas monitoring port includes a luer lock.

In another embodiment of the invention, there is provided a nasal ventilation mask having an exterior opening under a nose region in the mask, over the patient's
30 lip region, that allow gases expelled orally to be scavenged and ported to a scavenger device, said mask optionally further including a Scavenger line for diverting a portion of the expelled gas to be monitored for end-tidal CO₂, and, wherein a connector

preferably is provided at point where the end-tidal CO₂ monitoring line intercepts the Scavenger line, effectively diverting the gas flow, resulting in a positive pressure relative to the end-tidal CO₂ line whereby to permit gasses to be sampled from the scavenger line.

5 In such embodiment, the mask may further comprise an anesthesiologist controlled 2-way, 3 port valve permitting an anesthesiologist to switch between separately monitoring nasal and oral expulsions of end-tidal CO₂ or monitoring them simultaneously when the valve is open to both, wherein, when the Oral end-tidal CO₂ monitoring port is chosen, the end-tidal CO₂ monitoring line preferably also serves to
10 scavenge other ventilation gasses during anesthesia.

The present invention also provides a nasal ventilation mask having tabs or eyelets for attaching the mask anteriorly with the mask anchor, or posteriorly with a traditional anesthesia mask strap, said mask further optionally characterized by one or both of the following features:

15 (a) allowing only one combined anterior-posterior head strap to be attached, where the posterior head strap can attach to the mask alone, or can attach to the mask and then to a surface, which will prevent movement of the patient's head and/or neck; or

 (b) securing the patient's head with a head strap to the support surface,
20 where the patient's head will stay in a desired position and the support surface will stay in the desired position when the provider changes the head and/or neck angles.

In yet another embodiment of the invention there is provided a nasal mask characterized by one or more of the following features:

 (a) wherein the mask is usable as an oxygen transport mask or as a
25 Ventilation mask providing O₂ and anesthesia gases and for monitoring end-tidal CO₂ simultaneously;

 (b) having ports for monitoring end-tidal CO₂ via one or more ports, that can be used for CPAP pre-operatively, intra-operatively, and post-operatively;

 (c) having ports for monitoring end-tidal CO₂ via one or more ports, that
30 can be connected to a resuscitator bag in such a way that the patient's mouth and airway are not obstructed by the resuscitator bag to allow for direct laryngoscopy and intubation;

(d) wherein the mask is attachable anteriorly with a mask anchor, or posteriorly with a traditional anesthesia mask strap; and

(e) having an O₂ port for introducing oxygen into the mask, a ventilation port and a gas monitoring attachment integral to or attached to the ventilation port,
5 wherein the gas monitoring port preferably includes a luer lock

The present invention also provides an anesthesia mask having a built in scavenger system for collecting anesthetic gases that leak out around the mouth and/or nose.

In yet another embodiment, the present invention provides a chin strap for
10 application to the submental space, attached to a nasal mask, for applying pressure to force a wearer's tongue against the soft palate and induce an obstruction of the retro-glossal space, whereby to reduce or prevent leakage of gases out of the patient's mouth and allow the patient to breath out of the nose, wherein the chin strap also has the ability to release pressure, if needed, during exhalation to prevent an expiratory
15 obstruction.

In another aspect the present invention provides an improved CPR mask for mouth-to-mouth and/or nose-to-mouth resuscitation and includes a CO₂ absorber that eliminates re-breathing of rescuer or provider exhaled CO₂ by the victim. More particularly, the present disclosure provides a CPR mask which includes a CO₂ filter
20 or absorber built into the mask or mask inlet for absorbing CO₂ being exhaled by the rescuer or provider.

That is to say, there is provided a CPR mask for mouth-to-mouth and/or nose-to-mouth resuscitation, comprising a body shaped to cover the nose and/or mouth of a victim, said mask including a CO₂ absorber for eliminating at least in part rescuer
25 exhaled CO₂ delivered to the victim.

In one embodiment, the CO₂ absorber is coated on an inside surface of the mask.

In another embodiment, the mask includes a ventilation tube, wherein the CO₂ absorber is located in the ventilation tube.

30 In still another embodiment the mask includes one-way valve and/or straps for holding the mask to the head of the victim.

In one embodiment the mask includes a compliant periphery to conform to the face of a victim. In such embodiment, the periphery may include a soft, compliant air bladder, or resiliency deformable foam cushion.

In yet another embodiment, the mask includes a biological filter incorporated into the inside of the mask, or incorporated into the ventilation tube.

In still yet another embodiment of the invention, there is provided a CPR mask as above described, further characterized by one or more of the following features:

- (a) including a one-way valve;
- (b) including straps for holding the mask to the head of the victim;
- (c) wherein the mask further includes a compliant periphery to conform to the face of a wearer, wherein the periphery preferably includes a soft, compliant air bladder or a resiliently deformable foam cushion; and

Further features and advantages of the present invention will be seen from the following detailed description, taken in conjunction with the accompany drawings, wherein

Figs. 1a and 1b are front view and top views of a nasal ventilation mask in accordance with the first embodiment of the present invention;

Figure 2 is an inside view of the Fig. 1a ventilation mask;

Figs. 3a and 3b are plan views showing the ventilation mask in accordance with the present invention on a patient's head;

Figs. 4a and 4b are views similar to Figs. 3a and 3b showing a chin strap attached to the mask;

Figs. 5a and 5b show an alternative configuration of the nasal mask with an end-tidal CO₂ monitor in accordance with the present invention;

Fig. 6 is a side elevational view of an alternative configuration of nasal mask ventilation system in accordance with the present invention;

Fig. 7 is a plan view of an alternative embodiment of nasal ventilation mask with a CO₂ monitor in accordance with the present invention;

Fig. 8 is a plan view of yet another alternative configuration of nasal mask with a CO₂ monitor in accordance with the present invention;

Fig. 9 is a view, in partial cross-section of a CPR mask in accordance with the first embodiment of the present invention; and

Fig. 10 is a side elevational view of a second embodiment of a CPR mask in accordance with the present invention.

A nasal ventilation mask 10 in accordance with a first embodiment of the present invention is illustrated in Figures 1a and 1b. Optimally it contains 4 gas openings, but can contain less or more than four as well. The first is the ventilation port 12 that supplies O_2 and other gasses either during anesthesia or for NIPPV in critically ill patients and allows for any end-tidal CO_2 that is expelled nasally to be retrieved from the patient. The second is an Oral opening 14 under the nose but isolated from the nasal cavity created by the mask over the patient's nose. The purpose of opening 14 is for scavenging anesthesia gases and end-tidal CO_2 that are expelled orally from the patient. In addition to reducing or eliminating anesthetic gasses from entering the Operating Room and becoming a hazard, it allows for the end-tidal CO_2 expelled from the patient's lungs and escaping orally to be monitored. The third opening is the Gas Scavenging / end-tidal CO_2 port 16 that is connected to the opening by a channel 18 inside the mask (see Figure 2) that is isolated from the nasal cavity. The Gases, including any expelled end-tidal CO_2 , leave the mask through port 16 and are guided by a tube 20 to a gas scavenging filter and end-tidal CO_2 monitor 32 (see Figure 3) that samples gas from the gas scavenging line. The fourth opening is an O_2 port 22 that is capped off during anesthesia, but may be connected to an O_2 source (not shown) either pre-operation, intra-operation, or post-operation. When O_2 is supplied, the Ventilation tube is detached from the ventilation port 12 so that end-tidal CO_2 and be expelled nasally. A gas hood 24 located under the nose around the oral opening 14 extends beyond the mask as shown. It is optionally included in order to extend the influence of the Oral Opening 14 in the mask in order to contain a greater percentage of the expelled gases from the patient.

The mask also includes three eyelets or tabs 60, 62, 64, or four eyelets or tabs 66 68, 70, 72 (Fig. 7) for attaching a chin strap or head strap, as described below, or for attaching straps to the operating table in accordance with the teachings of our co-pending application PCT/US 14/44934 or our co-pending PCT application PCT/US1 5/34277.

An interior view of the nasal ventilation mask 10 of the present invention is illustrated in Figure 2. The ventilation port 12 and O_2 port 22, are connected to the

nasal cavity 26. Orally expelled gases travel from the Oral opening 14 on the outside of the mask through Gas Channel 18 and out the Gas Scavenger & end-tidal CO₂ monitoring port 16 on to the Scavenger device and end-tidal CO₂ monitor. The Gas channel 18 separates the Nasal cavity 26 created by the ventilation mask over the nose and the Oral regions of the patient.

When O₂ or O₂ and anesthesia gasses and are being supplied to the patient, they travel to the nasal cavity 26 through a ventilation circuit 28 attached to the ventilation port 12, and a cap shown in phantom at 30, seals the O₂ port. Post operation, the cap 30 can be removed from the O₂ port 22 and an O₂ line attached to the port, supplying O₂ to the patient. The ventilation circuit 28 is removed from the ventilation port 12 and the nasal cavity 26 is open to the atmosphere where end-tidal CO₂ can be expelled nasally.

The gas circuit for both the Nasal Mask Ventilation / end-tidal CO₂ monitor Oral Gas Scavenger / end-tidal CO₂ monitoring lines are illustrated in Figures 3a and 3b. Figure 3a shows nasal gas flow from the Nasal cavity 26 connected to the Ventilation Circuit 28 and to the end-tidal CO₂ monitoring equipment 32. Figure 3b shows the orally expelled gasses entering the Oral opening and flowing through the Gas Scavenger line to a recovery device 34 and the associated line that is connected to the scavenger line and flows to the end-tidal CO₂ monitoring equipment. Note that the opening to the scavenger line should be positioned approximately 90° to the scavenger gas flow in order for the local pressure to be higher than it would be if the opening were perpendicular to the gas flow. If it were perpendicular, a negative pressure would prevent the end-tidal CO₂ monitoring line from being able to sample the flow due to the negative pressure gradient.

Referring also to Figures 4a and 4b, a chin strap 36 also can be applied to the submental space, attached to the nasal mask 10, and apply a pressure to force the tongue against the soft palate and induce an obstruction of the retro-glossal space, which will help prevent any leak of gases out of the patient's mouth and allow the patient to breath out of the nose. The chin strap 36 also has the ability to release pressure, if needed, during exhalation to prevent an expiratory obstruction and allow end-tidal CO₂ and other gases to be released out the mouth.

In an alternate configuration, the gas circuit for both the Nasal Mask Ventilation and end-tidal CO₂ monitoring are illustrated in Figures 5a and 5b. The figure shows a 2-Way, 3 Port valve 40 that connects the Nasal circuit to the end-tidal CO₂ monitoring equipment. The anesthesiologist decides which region, the nasal, oral region, or both simultaneously, should be monitored for end-tidal CO₂.

A side view of the alternate configuration for the nasal mask ventilation and monitoring end-tidal CO₂ expulsion from the oral airway is illustrated in Figure 6. Note the 2-Way, 3 Port valve 40 has been turned in the direction of the mouth for sampling end-tidal CO₂.

The nasal ventilation mask also allows only one combined anterior-posterior head strap to be attached, where the posterior head strap can attach to the mask alone, or can attach to the mask and then to a surface, which will prevent movement of the patient's head and/or neck. By securing the patient's head with the head strap to the support surface, the patient's head will stay in the desired position and the support surface will stay in the desired position when the provider changes the head and/or neck angles.

Fig. 7 illustrates yet another embodiment of the invention, in which a patient is being provided oxygen via an O₂ line connected to the O₂ port on the ventilation mask. The exhaled gasses are exhausted to the atmosphere via the ventilation port 12 as illustrated in Fig. 7. If the patient is unconscious due to anesthesia, there is a desire to assure that the CO₂ is being exhaled. This can be accomplished by adding a "T-Shaped" gas monitoring attachment 50 that slides onto the mask ventilation port 12. The main body of the attachment 50 which is tubular in shape allows exhaled gasses to be exhausted to the atmosphere. To the side of the attachment is a tubular opening 52, nominally at a 90° angle off to the side. The end of this opening 52 can have a luer lock or any other kind of securing connection. Exhaled gas from the main flow can be sampled through this opening if a gas monitoring line 54 connected to a gas monitor is attached to the gas monitoring line interface.

An alternative approach for accomplishing the same gas sampling feature is illustrated in Fig. 8. In this embodiment, the gas monitoring line interface is an integral element of the mask ventilation port 12. In this configuration, O₂ flows into the O₂ port via a supply line and the exhaust gases are passed to the atmosphere via

the ventilation port 12. The side of the ventilation port 12 is a tubular opening 56, nominally at 90° angle off to the side. The end of this opening can have a luer lock or any other kind of securing connection. Exhaled gas from the main flow can be sampled through this opening if a gas monitoring line connected to a gas monitor is
5 attached to the gas monitoring line surface.

Referring to Fig. 9, there is shown a first embodiment of a CPR mask in accordance with another aspect of our invention, designated 110, to affect rescue breathing, mouth-to-mouth resuscitation or any other CPR procedure requiring emergency breathing assistance. Mask 110 is shaped to cover the nose and/or mouth
10 of a victim, and includes a soft and compliant periphery 112 to conform to the face of a victim upon application of moderate force to obtain a tight-fitting mask seal. Typically the periphery 112 of the mask includes a soft, compliant air bladder 114 or resiliently deformable foam cushion or the like.

A ventilation tube 116 is attached to an integral inlet port 118 protruding from
15 the mask through which air may be supplied by the rescuer by exhaling into the tube. Ventilation tube 116 or inlet port 118 typically includes a one-way valve 120 that permits air to enter the mask through tube 116. Ventilation tube 116 and its associated valve 120 may be formed integrally with the port 118, or may be a replaceable, disposable element or package. (Fig. 10).

20 The inside surface 122 of mask 110 is coated in part by a CO₂ absorbing material such as activated carbon or a zeolite. Also, certain minerals such as serpentinite advantageously may be employed. Typically, these materials are sorted to optimal size and encased in a filter material 124 bound to the inside surface 122 of the mask 110. Alternatively, the inside surface 122 of the mask 110 maybe coated
25 with a CO₂ absorbing polymer such as polyethylenimine containing fumed silica or the like as reported in Scientific American, January 6, 2012, page 33.

Alternatively, as shown in Fig. 10, a CO₂ filter 126 containing CO₂ absorbing material may be incorporated into ventilation tube 116.

30 In use, the rescuer places the CPR mask 110 over the nose and/or mouth of a victim to initiate emergency ventilation of the victim. The rescuer applies moderate force to obtain a substantially air-tight seal against the victim's face, and ventilation is then supplied by the rescuer by exhaling into the ventilation tube 116. While the

exhaust from the rescuer contains CO₂, most of the CO₂ will be removed by the CO₂ filter material.

Mask 110 may be formed in different sizes, for example, adult size, youth size and child size, to accommodate different size faces. A feature and advantage of the
5 CPR mask of the present invention is that significantly reduces the amount of CO₂ administered to the victim. Also, the mask helps to protect both victim and rescuer in an emergency situation by preventing transfer of disease.

Various changes may be made in the above invention without departing from the spirit and scope thereof. For example, a biological filter (shown in phantom at
10 130 in Fig. 10) also may be incorporated into the mask or the ventilation tube 116. Additionally, the mask may include straps 132 for strapping the mask to the victim's head, thus freeing the rescuer from having to press the mask against the victim's face. Still other changes are possible.

Claims:

What is claimed:

1. A nasal ventilation mask having one or more ports to monitor end-tidal CO₂ expulsion integrated into the mask, preferably separate ports, to monitor end-tidal
5 CO₂ expelled nasally or orally.
2. A nasal ventilation mask where anesthesia gasses and O₂ are provided nasally.
3. A nasal ventilation mask having an exterior opening under a nose region in the mask, over the patient's lip region, that allow gases expelled orally to be scavenged and ported to a scavenger device, said mask optionally further including a Scavenger
10 line for diverting a portion of the expelled gas to be monitored for end-tidal CO₂, and, wherein a connector preferably is provided at point where the end-tidal CO₂ monitoring line intercepts the Scavenger line, effectively diverting the gas flow, resulting in a positive pressure relative to the end-tidal CO₂ line whereby to permit gasses to be sampled from the scavenger line.
- 15 4. The nasal ventilation mask of claim 1, further comprising an anesthesiologist controlled 2-way, 3 port valve permitting an anesthesiologist to switch between separately monitoring nasal and oral expulsions of end-tidal CO₂ or monitoring them simultaneously when the valve is open to both, wherein, when the Oral end-tidal CO₂ monitoring port is chosen, the end-tidal CO₂ monitoring line preferably also serves to
20 scavenge other ventilation gasses during anesthesia.
5. A nasal ventilation mask having tabs or eyelets for attaching the mask anteriorly with the mask anchor, or posteriorly with a traditional anesthesia mask strap, said mask further optionally characterized by one or both of the following features:
25 (a) allowing only one combined anterior-posterior head strap to be attached, where the posterior head strap can attach to the mask alone, or can attach to the mask and then to a surface, which will prevent movement of the patient's head and/or neck; or
(b) securing the patient's head with a head strap to the support surface,
30 where the patient's head will stay in a desired position and the support surface will stay in the desired position when the provider changes the head and/or neck angles.
6. A nasal mask characterized by one or more of the following features:

- (a) wherein the mask is usable as an oxygen transport mask or as a Ventilation mask providing O₂ and anesthesia gases and for monitoring end-tidal CO₂ simultaneously;
- (b) having ports for monitoring end-tidal CO₂ via one or more ports, that
5 can be used for CPAP pre-operatively, intra-operatively, and post-operatively;
- (c) having ports for monitoring end-tidal CO₂ via one or more ports, that can be connected to a resuscitator bag in such a way that the patient's mouth and airway are not obstructed by the resuscitator bag to allow for direct laryngoscopy and intubation;
- 10 (d) wherein the mask is attachable anteriorly with a mask anchor, or posteriorly with a traditional anesthesia mask strap; and
- (e) having an O₂ port for introducing oxygen into the mask, a ventilation port and a gas monitoring attachment integral to or attached to the ventilation port, wherein the gas monitoring port preferably includes a luer lock
- 15 7. An anesthesia mask having a built in scavenger system for collecting anesthetic gases that leak out around the mouth and/or nose.
8. A chin strap for application to the submental space, attached to a nasal mask, for applying pressure to force a wearer's tongue against the soft palate and induce an obstruction of the retro-glossal space, whereby to reduce or prevent leakage of gases
20 out of the patient's mouth and allow the patient to breath out of the nose, wherein the chin strap also has the ability to release pressure, if needed, during exhalation to prevent an expiratory obstruction.
9. A CPR mask for nose-to-mouth and/or mouth-to-mouth resuscitation, comprising a body shaped to cover the nose and/or mouth of a victim, said mask including a C(¾) absorber
25 for eliminating at least in part rescuer's exhaled CO₂ delivered to the victim.
10. The CPR mask of claim 9, wherein the CO₂ absorber is coated on an inside surface of the mask.
11. The CPR mask of claim 9 or claim 10, wherein the mask further includes a ventilation tube, wherein the CO₂ absorber is located in the ventilation tube.
- 30 12. The CPR mask of claim 11, further including a biological filter, incorporated into the ventilation tube.
13. The CPR mask of any of claims 9-12, further characterized by one or more of the following features:

- (a) including a one-way valve;
- (b) including straps for holding the mask to the head of the victim;
- (c) wherein the mask further includes a compliant periphery to conform to the face of a wearer, wherein the periphery preferably includes a soft, compliant air bladder or a
5 resiliently deformable foam cushion; and
- (d) further including a biological filter incorporated into an inside of the mask.

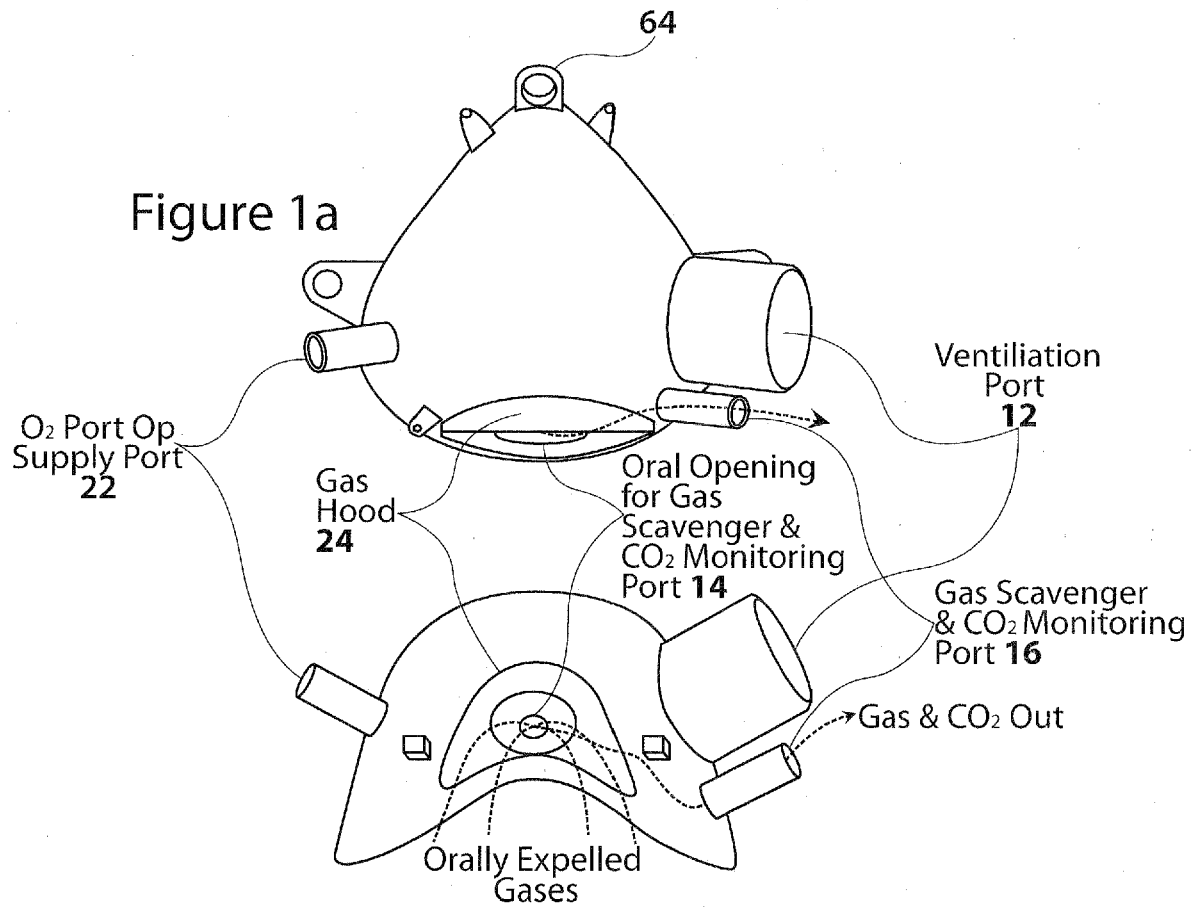

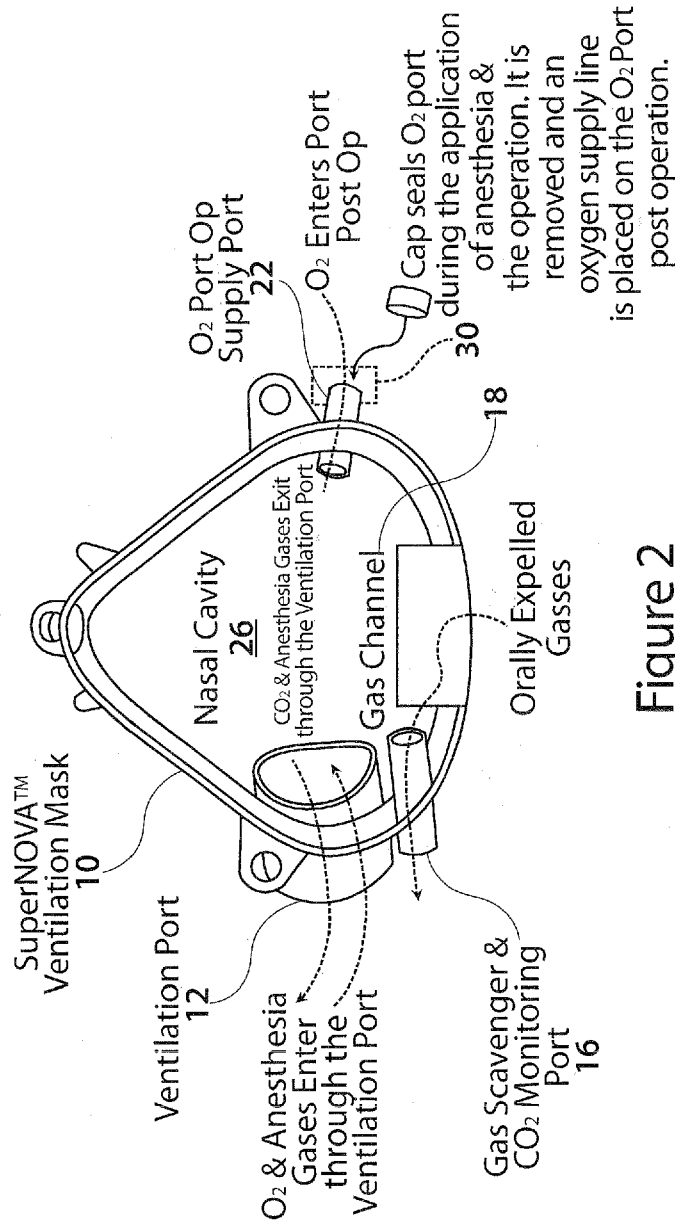

Figure 2

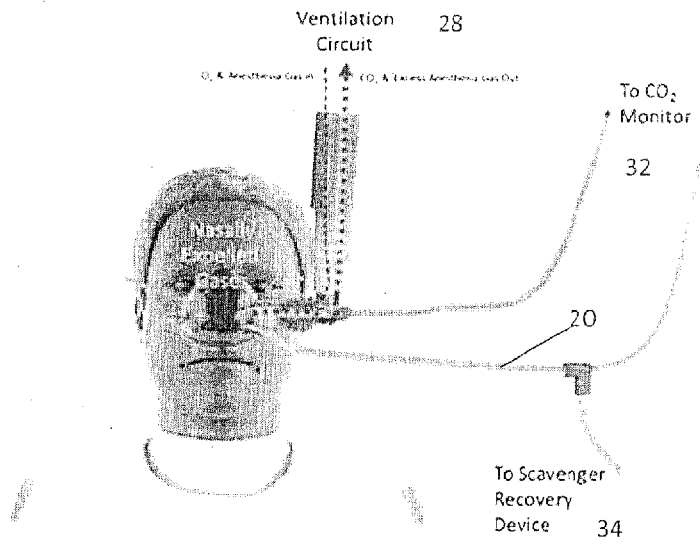

Figure 3a

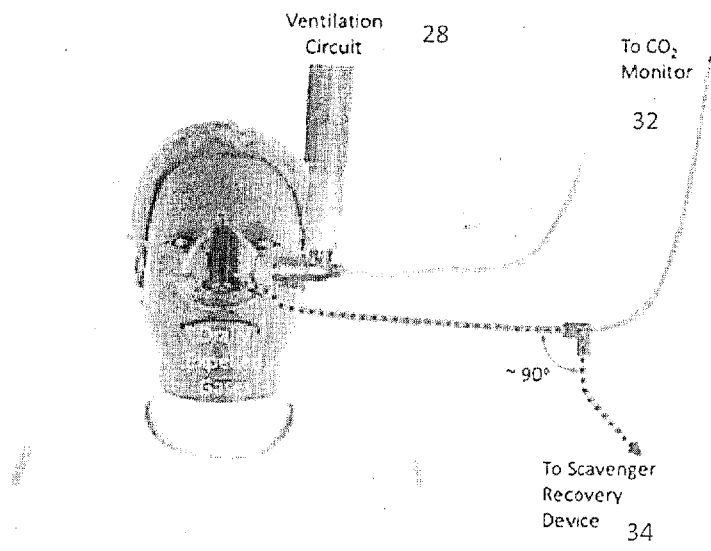

Figure 3b

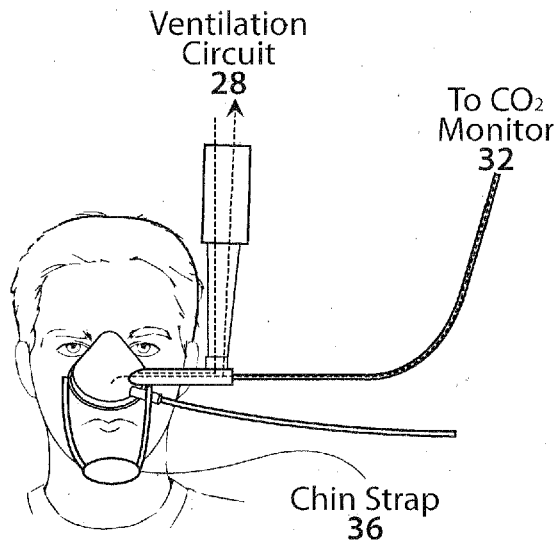

Figure 4a

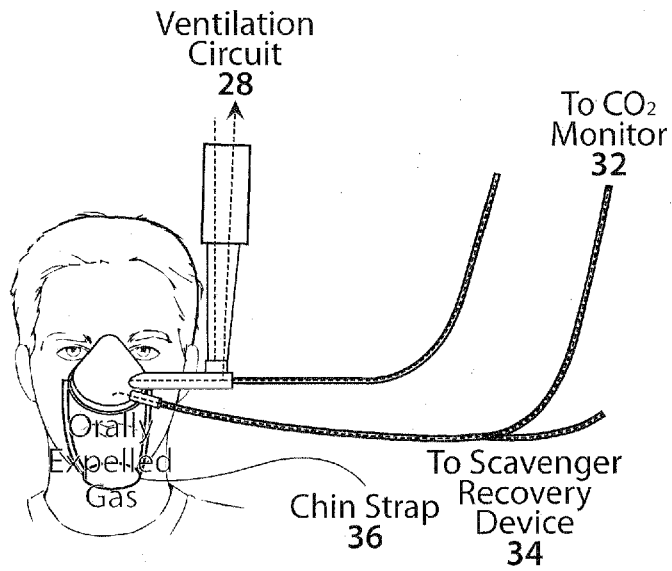

Figure 4b

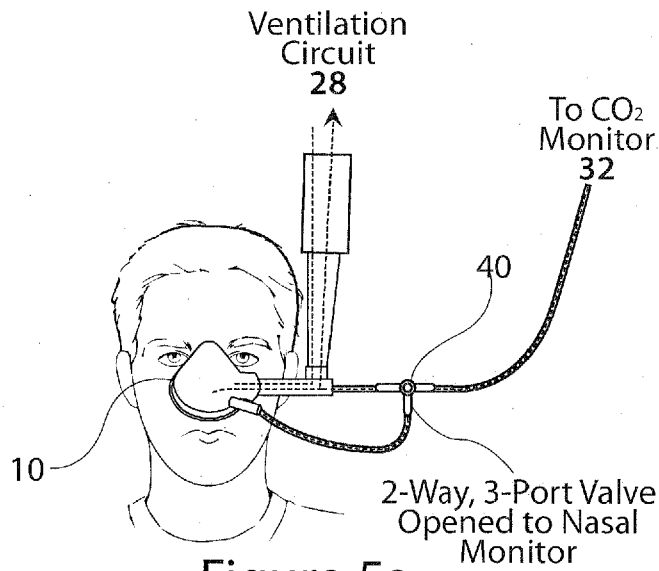

Figure 5a

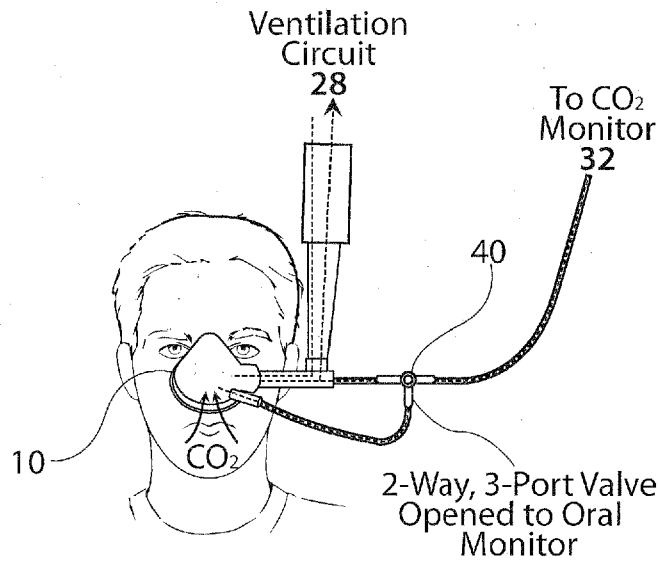

Figure 5b

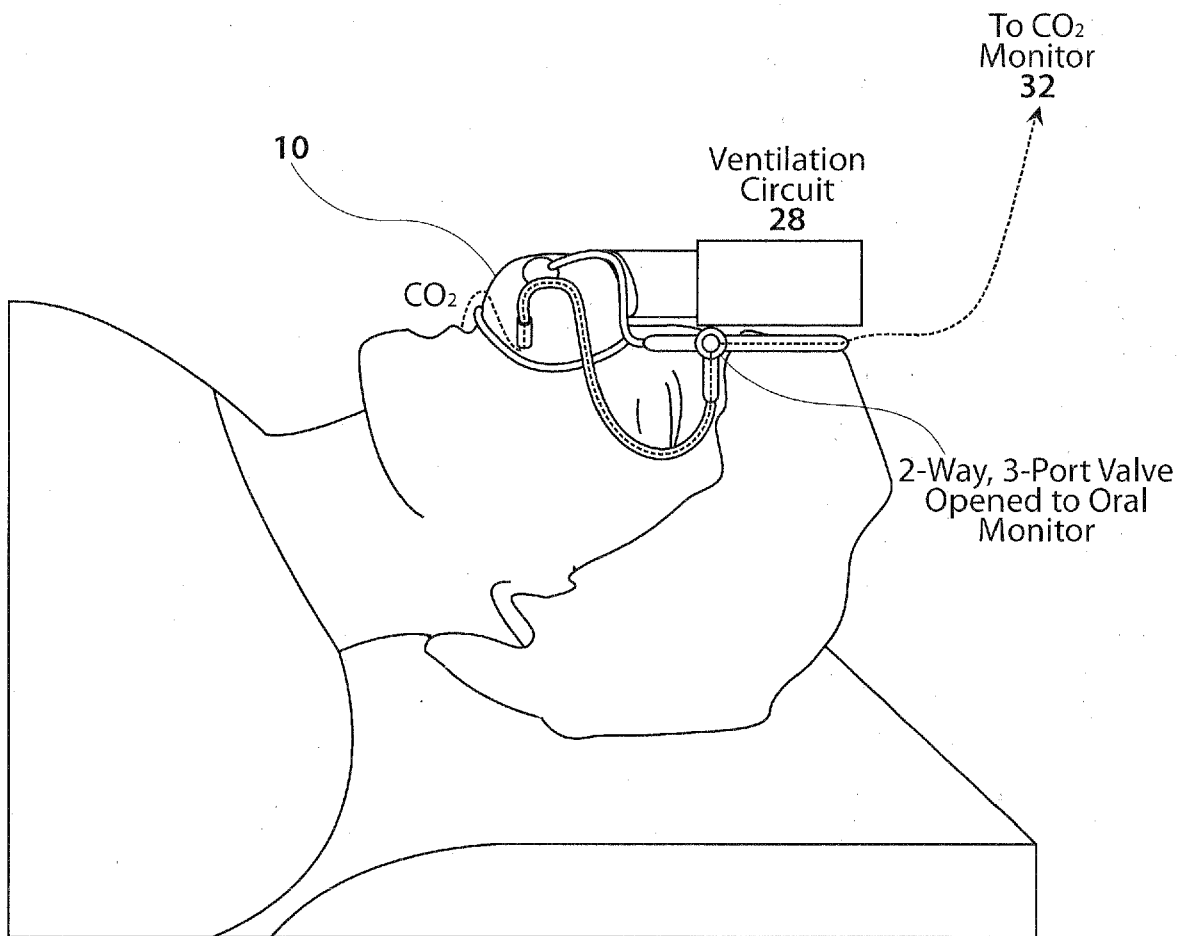

Figure 6

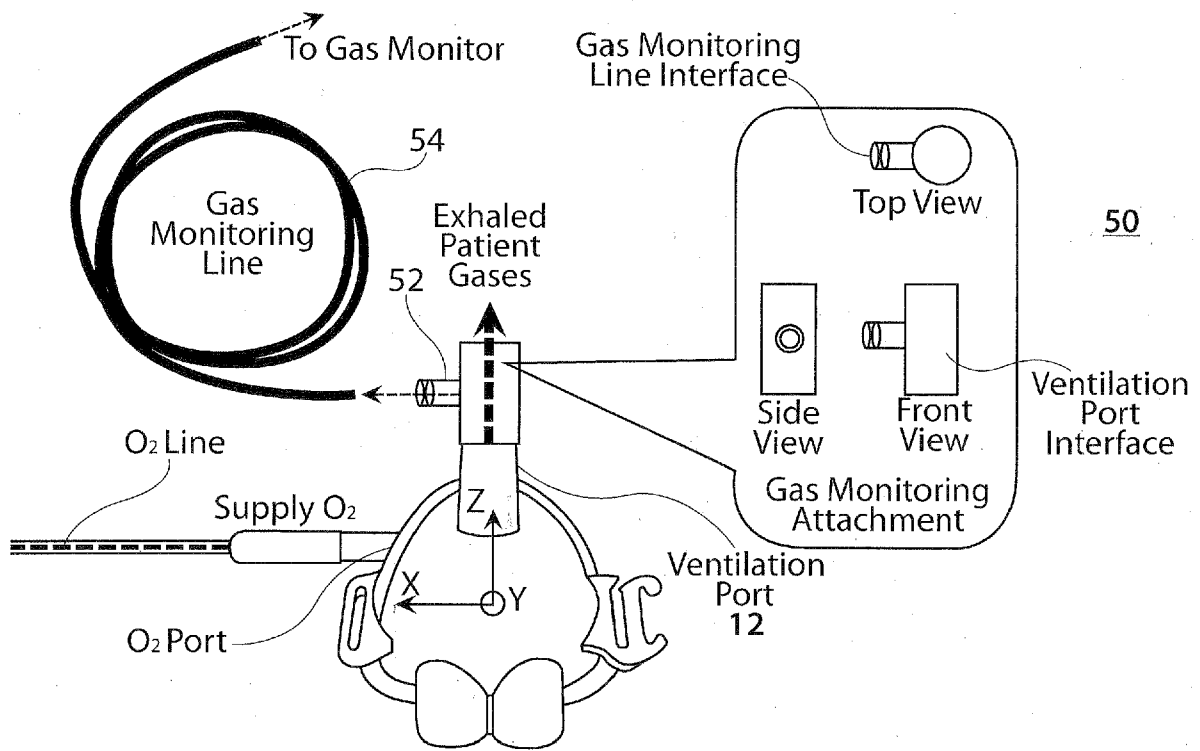

Figure 7

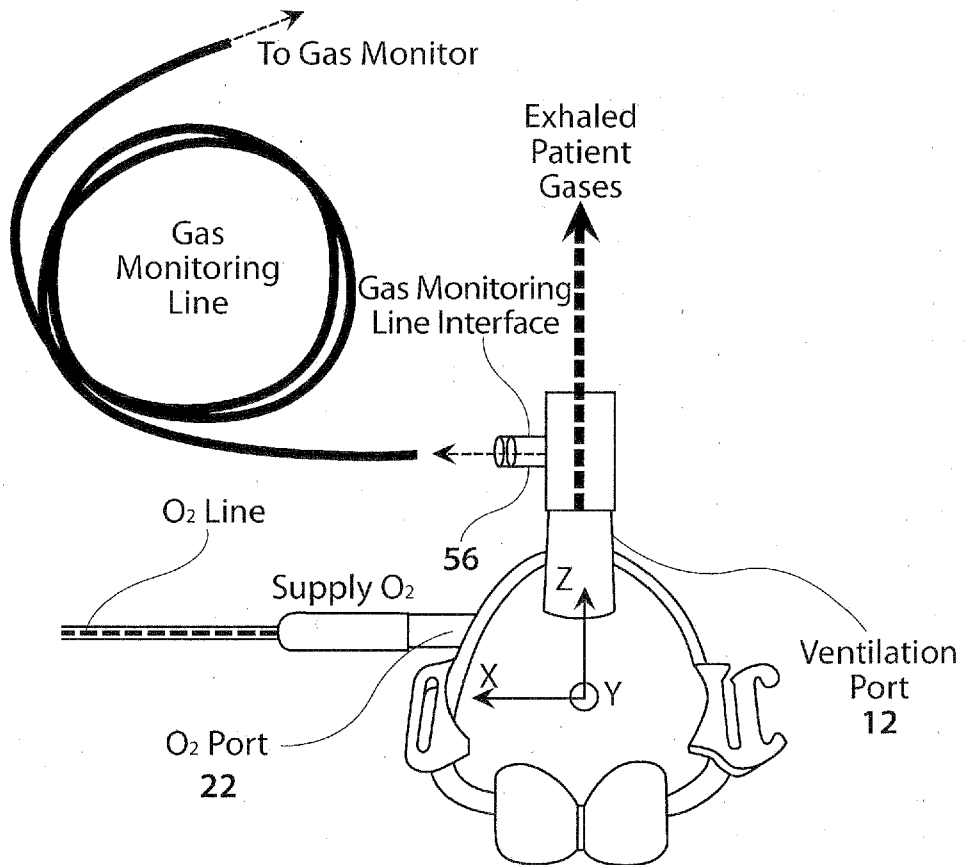

Figure 8

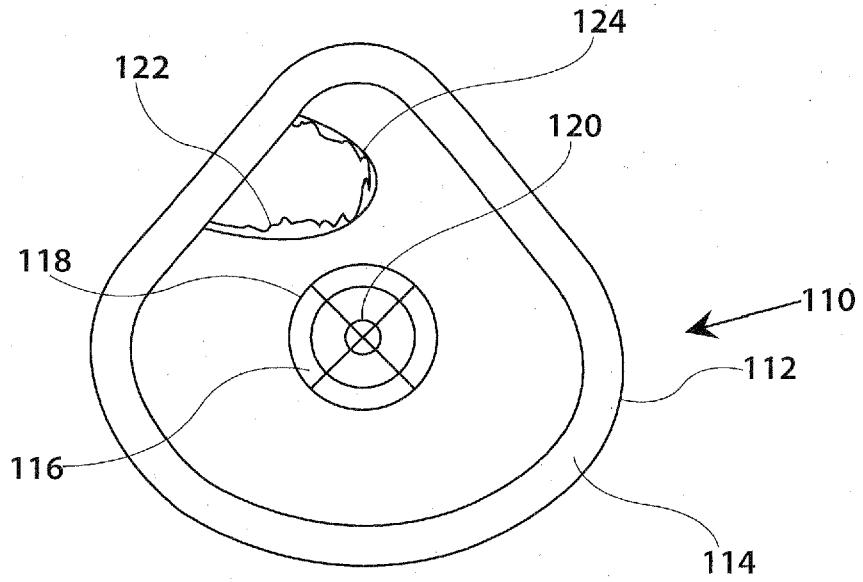

Figure 9

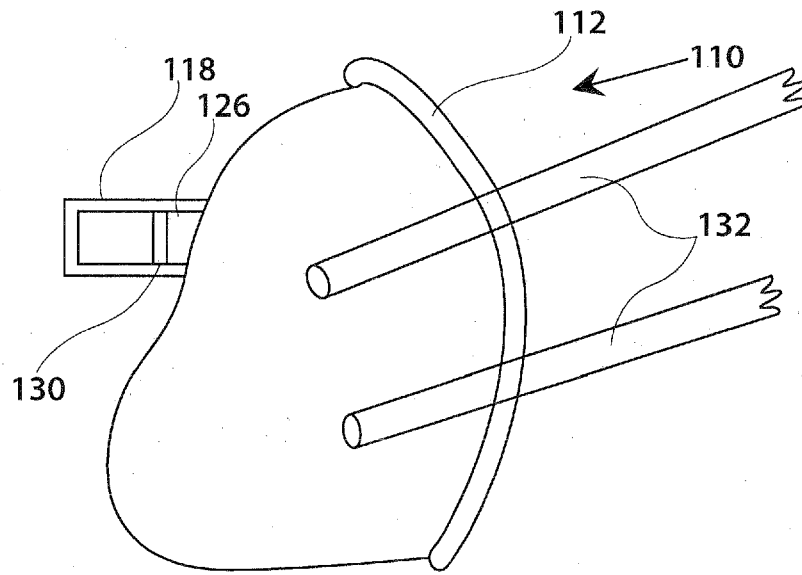

Figure 10

INTERNATIONAL SEARCH REPORT

International application No.

PCT/US20 15/044341

A. CLASSIFICATION OF SUBJECT MATTER

IPC(8) - A61M 16/00 (2015.01)

CPC - A61M 16/00 (2015.12)

According to International Patent Classification (IPC) or to both national classification and IPC

B. FIELDS SEARCHED

Minimum documentation searched (classification system followed by classification symbols)

IPC(8) - A61B 5/08, 5/083, 5/087, 5/097; A61M 16/00, 16/01, 16/06, 16/10, 16/12, 16/20, 16/22; A62B 7/00; G01N 33/497 (2015.01)

CPC - A61B 5/083, 5/0836, 5/097; A61M 16/00, 16/0048, 16/009, 16/0093, 16/01, 16/06, 16/20, 16/22; G01 N 33/497; (continued below)

Documentation searched other than minimum documentation to the extent that such documents are included in the fields searched

CPC - Y10S 128/91 (2015.12) (keyword delimited)

USPC - 128/202.28, 203.1 1, 203.12, 203.14, 204.18, 204.23, 204.26, 205.12, 205.24, 205.25, 206.21, 206.24, 207.13, 910; 600/531, 532

Electronic data base consulted during the international search (name of data base and, where practicable, search terms used)

PatBase, Google Patents, Google.

Search terms used: anesthesia, ventilation, respiration, mask, piece, monitor, record, track, end tidal, carbon dioxide, CO2, scavenge, two way, valve, oral, mouth, nasal, nose

C. DOCUMENTS CONSIDERED TO BE RELEVANT

| Category* | Citation of document, with indication, where appropriate, of the relevant passages | Relevant to claim No. |
|-----------|--|-----------------------|
| X | US 2013/0060157 A 1 (BEARD) 07 March 2013 (07.03.2013) entire document | 1-3, 6, 7 |
| X | US 2006/0042631 A 1 (MARTIN et al) 02 March 2006 (02.03.2006) entire document | 1, 4 |
| X | US 5,685,298 A (IDRIS) 11 November 1997 (11.11.1997) entire document | 9-12 |

Further documents are listed in the continuation of Box C.

See patent family annex.

| | |
|---|--|
| * Special categories of cited documents: | "T" later document published after the international filing date or priority date and not in conflict with the application but cited to understand the principle or theory underlying the invention |
| "A" document defining the general state of the art which is not considered to be of particular relevance | "X" document of particular relevance; the claimed invention cannot be considered novel or cannot be considered to involve an inventive step when the document is taken alone |
| "E" earlier application or patent but published on or after the international filing date | "Y" document of particular relevance; the claimed invention cannot be considered to involve an inventive step when the document is combined with one or more other such documents, such combination being obvious to a person skilled in the art |
| "L" document which may throw doubts on priority claim(s) or which is cited to establish the publication date of another citation or other special reason (as specified) | "G" document member of the same patent family |
| "O" document referring to an oral disclosure, use, exhibition or other means | |
| "P" document published prior to the international filing date but later than the priority date claimed | |

Date of the actual completion of the international search

10 December 2015

Date of mailing of the international search report

07 JAN 2016

Name and mailing address of the ISA/

Mail Stop PCT, Attn: ISA/US, Commissioner for Patents
P.O. Box 1450, Alexandria, Virginia 22313-1450

Facsimile No. 571-273-8300

Authorized officer

Blaine Copenheaver

PCT Helpdesk: 571-272-4300
PCT OSP: 571-272-7774

INTERNATIONAL SEARCH REPORT

International application No.

PCT/US2015/044341

Box No. II Observations where certain claims were found unsearchable (Continuation of item 2 of first sheet)

This international search report has not been established in respect of certain claims under Article 17(2)(a) for the following reasons:

1. Claims Nos.:
because they relate to subject matter not required to be searched by this Authority, namely:

2. Claims Nos.:
because they relate to parts of the international application that do not comply with the prescribed requirements to such an extent that no meaningful international search can be carried out, specifically:

3. Claims Nos.: 13
because they are dependent claims and are not drafted in accordance with the second and third sentences of Rule 6.4(a).

Box No. III Observations where unity of invention is lacking (Continuation of item 3 of first sheet)

This International Searching Authority found multiple inventions in this international application, as follows:

See extra sheet.

1. As all required additional search fees were timely paid by the applicant, this international search report covers all searchable claims.
2. As all searchable claims could be searched without effort justifying additional fees, this Authority did not invite payment of additional fees.
3. As only some of the required additional search fees were timely paid by the applicant, this international search report covers only those claims for which fees were paid, specifically claims Nos.:
1-4, 6, 7, 9-12
4. No required additional search fees were timely paid by the applicant. Consequently, this international search report is restricted to the invention first mentioned in the claims; it is covered by claims Nos.:

Remark on Protest

- The additional search fees were accompanied by the applicant's protest and, where applicable, the payment of a protest fee.
- The additional search fees were accompanied by the applicant's protest but the applicable protest fee was not paid within the time limit specified in the invitation.
- No protest accompanied the payment of additional search fees.

INTERNATIONAL SEARCH REPORT

Information on patent family members

International application No.

PCT/US2015/044341

Continuation of Box No. III Observations where unity of invention is lacking

This application contains the following inventions or groups of inventions which are not so linked as to form a single general inventive concept under PCT Rule 13.1. In order for all inventions to be examined, the appropriate additional examination fees must be paid.

Group I, claims 1, 2, 4, and 6, are drawn to a nasal ventilation mask where anesthesia gasses and O₂ are provided nasally.

Group II, claims 1, 3, 4, and 7, are drawn to an anesthesia mask having a built in scavenger system.

Group III, claim 5, are drawn to a nasal ventilation mask having tabs or eyelets.

Group IV, claim 8, are drawn to a chin strap.

Group V, claims 9-12, are drawn to a CPR mask comprising a CO₂ absorber.

The inventions listed as Groups I-V do not relate to a single general inventive concept under PCT Rule 13.1 because, under PCT Rule 13.2, they lack the same or corresponding special technical features for the following reasons:

The special technical features of Group I, a nasal ventilation mask where anesthesia gasses and O₂ are provided nasally, are not present in Groups II-V; the special technical features of Group II, an anesthesia mask having a built in scavenger system for collecting anesthetic gases that leak out around the mouth and/or nose, are not present in Groups I and III-V; the special technical features of Group III, a nasal ventilation mask having tabs or eyelets for attaching the mask anteriorly with the mask anchor, or posteriorly with a traditional anesthesia mask strap, said mask further optionally characterized by one or both of the following features: (a) allowing only one combined anterior-posterior head strap to be attached, where the posterior head strap can attach to the mask alone, or can attach to the mask and then to a surface, which will prevent movement of the patient's head and/or neck; or (b) securing the patient's head with a head strap to the support surface, where the patient's head will stay in a desired position and the support surface will stay in the desired position when the provider changes the head and/or neck angles, are not present in Groups I-II and IV-V; the special technical features of Group IV, a chin strap for application to the submental space, attached to a nasal mask, for applying pressure to force a wearer's tongue against the soft palate and induce an obstruction of the retro-glossal space, whereby to reduce or prevent leakage of gases out of the patient's mouth and allow the patient to breath out of the nose, wherein the chin strap also has the ability to release pressure, if needed, during exhalation to prevent an expiratory obstruction, are not present in Groups I-III and V; and the special technical features of Group V, a CPR mask for nose-to-mouth and/or mouth-to-mouth resuscitation, comprising a body shaped to cover the nose and/or mouth of a victim, said mask including a CO₂ absorber for eliminating at least in part rescuer's exhaled CO₂ delivered to the victim, are not present in Groups I-IV.

Groups I and II share the technical feature of a nasal ventilation mask having one or more ports to monitor end-tidal CO₂ expulsion integrated into the mask, preferably separate ports, to monitor end-tidal CO₂ expelled nasally or orally. However this shared technical feature does not represent a contribution over the prior art. Specifically US 2011/0186050 A1 to Daly disclose a nasal ventilation mask (mask 104; FIGS. 1A-B) having one or more ports (ventilation orifices 131, 133, 135; FIGS. 1A-B) to monitor end-tidal CO₂ expulsion integrated into the mask (para. [0096] "airflow through each of the multiple ventilation orifices 131, 133, 135 is measured" and para. [0086] "rates of airflow through the orifices and the airflow meters and the percentage of CO₂ in the air, as measured by the end-tidal CO₂ monitor"), preferably separate ports (ventilation orifices 131, 133, 135; FIGS. 1A-B), to monitor end-tidal CO₂ expelled nasally or orally (para. [0086] and [0096]).

Groups I and III share the technical feature of a nasal ventilation mask wherein the mask is attachable anteriorly with a mask anchor, or posteriorly with a traditional anesthesia mask strap. However this shared technical feature does not represent a contribution over the prior art. Specifically US 2011/0186050 A1 to Daly disclose a nasal ventilation mask (mask 104; FIGS. 1A-B) wherein the mask is attachable anteriorly with a mask anchor, or posteriorly with a traditional anesthesia mask strap (multiple straps 103; FIGS. 1A-B; para. [0060] "multiple straps 103 secure the mask 104 to the face of patient 101 so that there is a substantially sealed connection between the mask and the patient's breathing airway (e.g., nose or mouth)").

Unity exists between claims 1, 2, 4, and 6 (Group I) and claims 1, 3, 4, and 7 (Group II). However, unity does not exist between claims 2 and 6, and claims 3 and 7, since there exists no common special technical feature between independent claims 2 and 6, and independent claims 3 and 7 (see PCT Examination Guidelines Chapter 10 at 10.22 Example 2).

Since none of the special technical features of the Group I-V inventions are found in more than one of the inventions, unity of invention is lacking.