

Jan. 6. 1925.

1,521,626

R. R. HUGHES, JR

TRIMMING MECHANISM FOR SEWING MACHINES

Filed Sept. 24, 1919

3 Sheets-Sheet 1

FIG. 1.

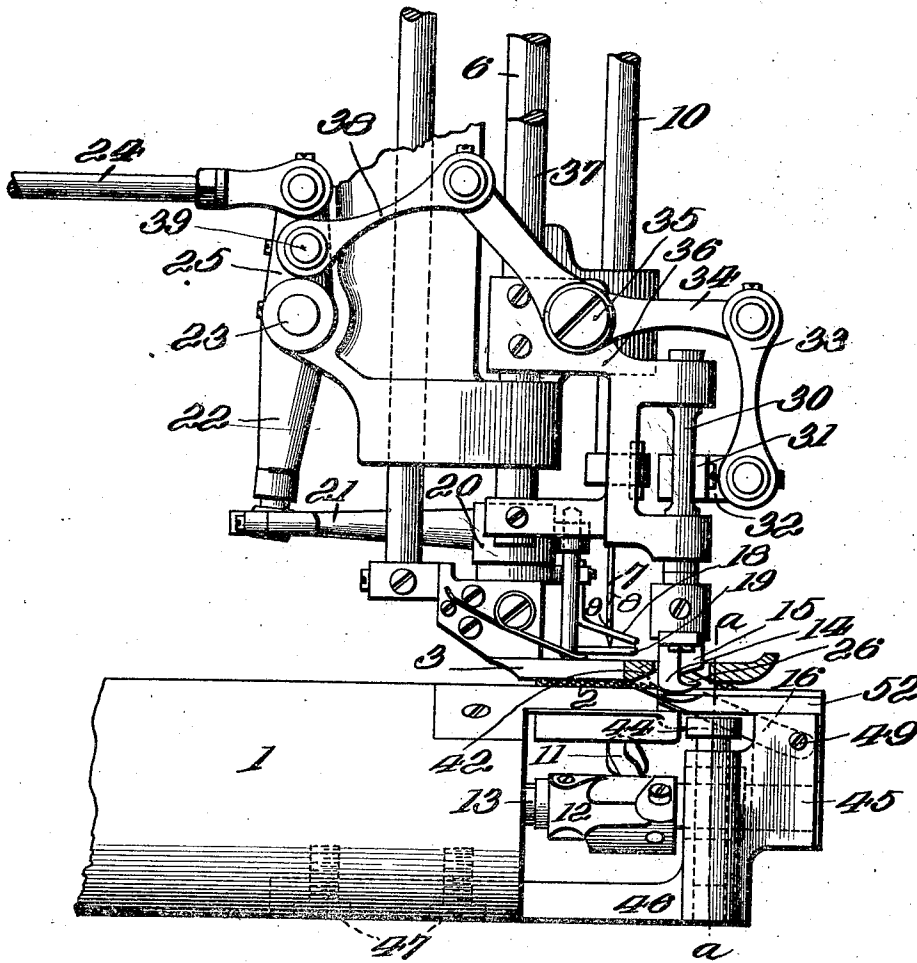

Inventor

Robert R. Hughes Jr

By Stewart Mason
Attorneys

Jan. 6, 1925.

1,521,626

R. R. HUGHES, JR

TRIMMING MECHANISM FOR SEWING MACHINES

Filed Sept. 24, 1919

3 Sheets-Sheet 2

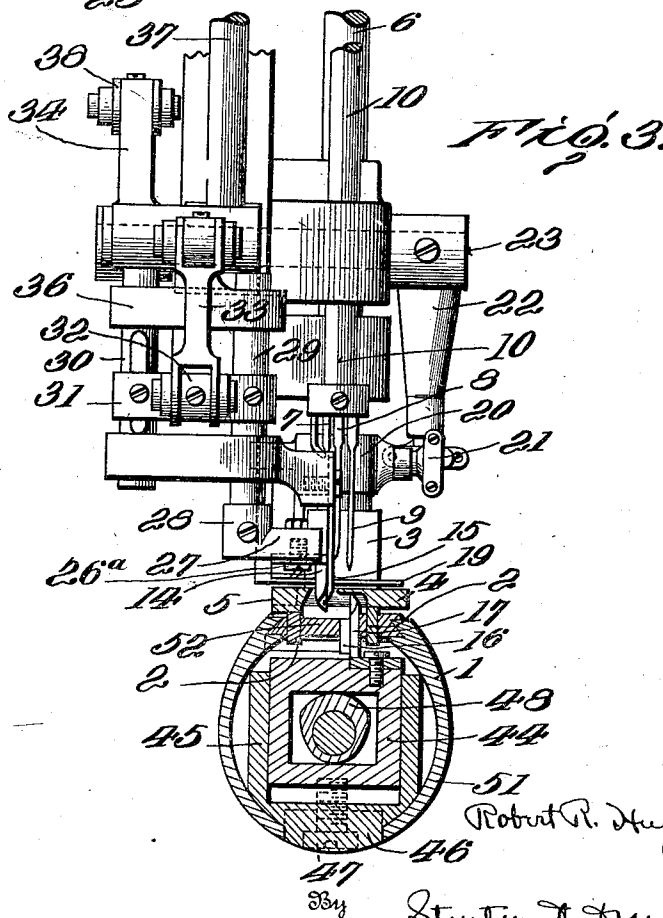
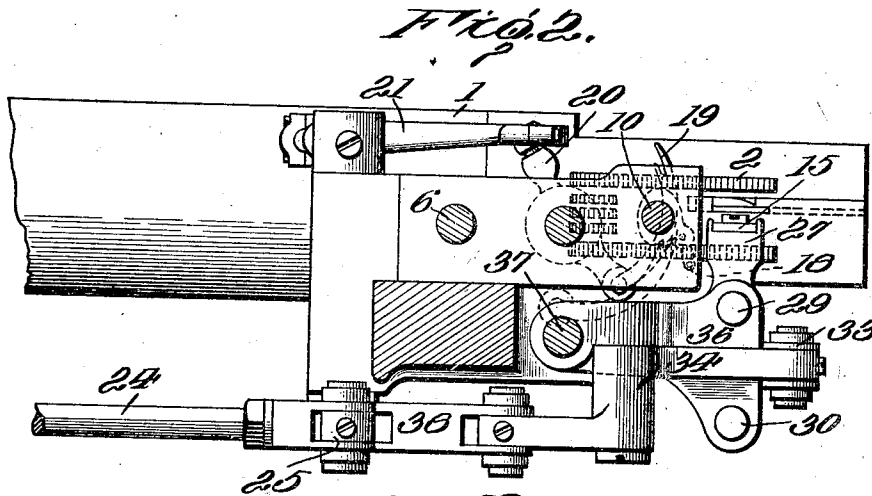

Inventor
Robert R. Hughes for
Sturtevant Mason
Attorneys

Jan. 6, 1925.

1,521,626

R. R. HUGHES, JR

TRIMMING MECHANISM FOR SEWING MACHINES

Filed Sept. 24, 1919

3 Sheets-Sheet 3

FIG. 4.

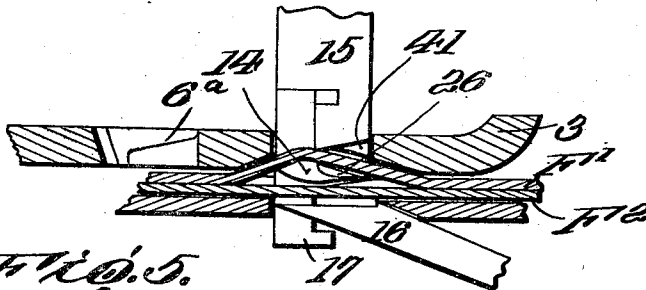

FIG. 5.

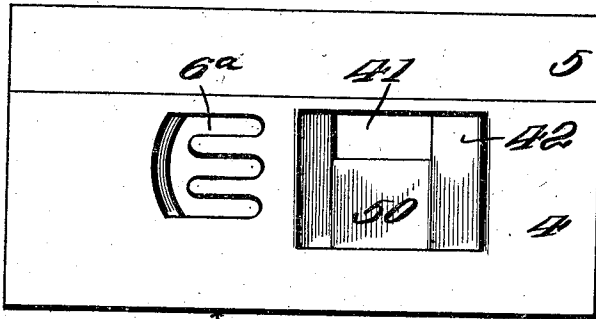

FIG. 9.

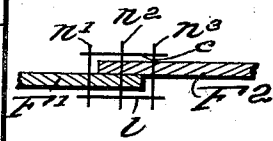

FIG. 6.

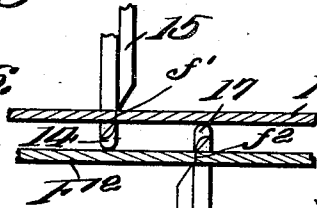

FIG. 8.

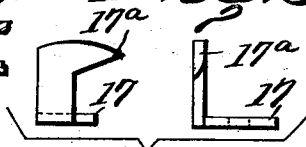
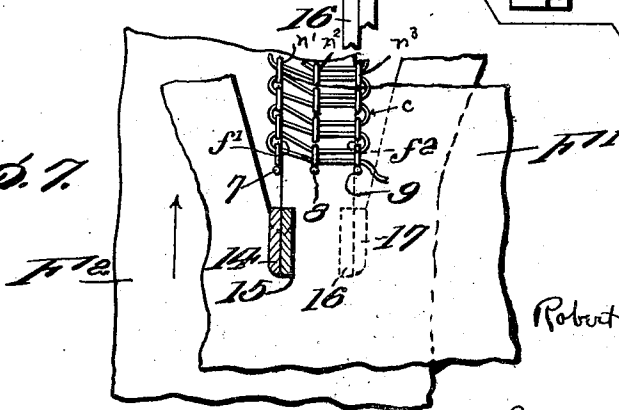

FIG. 7.



Inventor
Robert R. Hughes Jr

Sturtevant Mason
Attorney

334

UNITED STATES PATENT OFFICE.

ROBERT R. HUGHES, JR., OF UTICA, NEW YORK, ASSIGNOR TO UNION SPECIAL MACHINE COMPANY, OF CHICAGO, ILLINOIS, A CORPORATION OF ILLINOIS.

TRIMMING MECHANISM FOR SEWING MACHINES.

Application filed September 24, 1919. Serial No. 325,853.

To all whom it may concern:

Be it known that I, ROBERT R. HUGHES, Jr., a citizen of the United States, residing at Utica, in the county of Oneida, State of New York, have invented certain new and useful Improvements in Trimming Mechanism for Sewing Machines, of which the following is a description, reference being had to the accompanying drawing and to the figures of reference marked thereon.

The invention relates to new and useful improvements in sewing machines, and more particularly to a sewing machine having a trimming mechanism for trimming the edge portions of fabric sections which are subsequently stitched in flat overlapped relation to each other.

An object of the invention is to provide a sewing machine of the above character, wherein the fabric sections may be fed to the stitching mechanism with the edge portions thereof overlapped and said edge portions trimmed just in advance of the stitching mechanism and while in overlapped relation to each other.

A still further object of the invention is to provide a machine of the above character having stitching mechanism for covering the edge portions of the fabric sections, and wherein the trimming devices are so disposed as to cut the respective edges on parallel lines located within the limits of the stitching mechanism, so that said cut edges will be covered.

These and other object will in part be obvious and will in part be hereinafter more fully disclosed.

In the drawings which show by way of illustration one embodiment of the invention—

Figure 1 is a view partly in section and partly in side elevation, showing a portion of a sewing machine having my improvements embodied therein;

Figure 2 is a view partly in section and partly in plan, of the parts shown in Figure 1, the presser foot being omitted to show the parts beneath the same;

Figure 3 is a view partly in section and partly in front elevation of the parts shown in Figure 1, the section being along the line *a-a*;

Figure 4 is a longitudinal sectional view through a part of the presser foot and a

part of the work support, along one of the trimming lines;

Figure 5 is a bottom plan view of the presser foot;

Figure 6 is a view showing diagrammatically two fabric sections and the trimming devices operating thereon;

Figure 7 is a view showing diagrammatically the fabric sections, the needles, the trimming devices and their relation to the needles;

Figure 8 is a detail view showing a side elevation and in plan one of the lower trimming members;

Figure 9 is a diagrammatic view showing overlapped fabric sections which have been trimmed and stitched on my improved machine.

In the patent granted to Joseph Berger, Jr., November 20, 1917, No. 1,247,072, there is shown and described a sewing machine having means for trimming the edge portions of two fabric sections and overlapping said edge portions and subsequently stitching the same by covering stitches which cover the cut edges and firmly join the overlapped fabric sections.

The present invention is directed to an improvement upon the machine of this patent.

In said patent the edge portions are turned out of the plane of the fabric sections for trimming and a specially constructed presser foot is necessary to bring said edge portions back into overlapped relation. My invention is directed, broadly, to a trimming mechanism which is provided with trimming devices so disposed as to operate independently upon the respective edge portions of the fabric sections for cutting the edges thereof and without turning the edge portions of the fabric sections out of the plane of the fabric sections, as in said Berger patent. These trimming devices may be of any desired type for accomplishing the result. Said trimming devices are located within the limits of the stitch forming mechanism, so that the threads of the stitch forming mechanism not only join the overlapped edge portions but cover the cut edges thereof.

Referring more in detail to the drawings, I have shown the invention as embodied in a sewing machine having a work supporting arm 1, which is provided with a feed

dog 2 disposed so as to feed the material on to the work supporting arm. Co-operating with said feed dog is a presser foot 3, which may be provided with a yielding section 4 and a fixed section 5—that is, a section which is fixed to the presser bar 6 and moves up and down therewith. Said presser foot is provided with an opening 6^a for the needles. As shown in the drawings, the machine is provided with three needles 7, 8 and 9 arranged in a line at right angles to the line of feed. These needles are carried by a needle bar 10, which is reciprocated in the usual manner in the overhanging arm of the machine. Co-operating with the needles beneath the work support, is a thread carrying looper 11 mounted on a looper carrier 12, which is fixed to a looper shaft 13 extending lengthwise of the work supporting arm 1.

In Figure 7 of the drawings, I have shown two fabric sections F' and F², the edge portions of which are overlapped. The edge portion F' is cut along the line f', while the edge portion F² is cut along the line f².

This cutting takes place without turning the edge portion of the fabric sections out of the plane of the fabric sections to any appreciable extent, and said lines along which the fabric sections are cut pass just inside of the needles 7 and 9, respectively. The threads of the needles 7, 8 and 9, are shown, respectively, at n', n² and n³. The cross thread is shown at c and the looper thread at l. It will be seen that the edge portions of the fabric sections are joined by the stitching threads, the needle 8 passing through both fabric sections and the needles 7 and 9 passing through the respective fabric sections F² and F' only. The cross thread c on the upper side and the looper thread l on the underside, which interlock with all the needle loops, cover these overlapped sections of the fabric and also cover the cut edges.

As above noted the invention is directed particularly to the trimming mechanism which cuts the fabric sections along the line indicated and in advance of the needles. The fabric section F' is cut by two co-operating cutting devices 14 and 15, while the fabric section F² is cut along the line f² by the cutting devices 16 and 17.

The cross thread c is led through a thread guide 18 and is laid into loops by means of a thread hook 19. This thread hook 19 is mounted on a carrier 20, which is oscillated by means of a link 21 connected to an arm 22. The arm 22 is fixed to a shaft 23, mounted in the overhanging arm. This shaft 23 is in turn oscillated by means of a link 24 connected to the outer end of an arm 25, fixed to the shaft 23. This cross thread laying mechanism per se forms no part of the present invention, and is shown, described and claimed in the application of

James R. Moffatt, Serial No. 225,488, filed March 29, 1918, patented January 25, 1921, Number 1,366,476.

The trimming device 14 is shown in detail in Figures 1, 3 and 4. Said device has a supporting shank, at the lower end of which is a forwardly projecting pointed cutting member 26. Said cutting member is rounded on its lower face and the upper edge thereof is the cutting edge. This cutting member is secured by a screw 26^a to a supporting arm 27 projecting laterally from the collar 28 fixed to a vertically reciprocating shaft 29. Said shaft slides in suitable bearings in the overhanging arm. Also mounted in said bearings is a guide rod 30 which freely slides up and down in bearings in the overhanging arm. The vertical shaft 29 and the guide rod 30 are connected by a cross head 31. Extending outwardly from the cross head is an arm 32, to which a link 33 is pivotally connected at its lower end. A lever 34 is fulcrumed at 35 on the bracket 36 which carries the bearings for the vertical shaft 29 and the guide rod 30. This bracket is preferably clamped to the auxiliary presser rod 37 which is mounted in bearings in the overhanging arm. The lever 34 is pivotally connected at its outer end to the link 33. The other end of this lever 34 is connected to a link 38 which is pivoted at 39 to the arm 25. As the arm 25 oscillates, it will swing the lever 34 and this will raise and lower the vertical shaft 29 and thus reciprocate the trimming device 14. Associated with this movable trimming device 14 is the fixed trimming blade 15. This fixed trimming blade 15 is secured to the bracket 36. The auxiliary presser rod 37 moves up and down in the usual manner with the presser foot and therefore the trimming devices 14 and 15 will move up and down with the presser foot and may be raised with the presser foot to facilitate the removal of the fabric from the machine. The presser foot is formed with an opening 41, see Figures 1, 4 and 5, in which these trimming devices operate. Said presser foot is also provided with a recessed portion 42, in its underface, which permits the fabric section F' which overlaps the fabric section F² to be raised by the projecting blade 26 of the cutting device 14. In other words this pointed projecting blade 14, with its under rounded face, serves the double function of separating the two layers of fabric and of co-operating with the stationary blade in the cutting of the upper layer only. The cutting device 14 is so disposed that the shank of this cutting device is directly in front of the needle 7 and said shank serves as a separating means for deflecting the trimmed off edge of the fabric section F' to the left of the needle 7, see Figure 7 of the drawings. The cutting face of the trim-

ming device 14 is substantially in line with the inner surface of the needle 7, so that the cutting edge passes just inside the vertical path of said needle. The cutting devices 16 and 17 operate upon the lower section of the fabric only. The cutting device 17 is formed with a shank which projects upwardly and at its upper end said shank has a forwardly projecting blade 17^a which is shaped similar to the blade 26 except that the rounded face is on the upper edge of said projecting blade and the cutting edge is on the lower portion of the blade. This cutting device 17 is carried by a reciprocating slide 44 which is mounted to reciprocate vertically in a frame 45. This frame 45 is provided with an arm 46 which extends along the lower face of the work supporting arm and is secured thereto by screws 47. The shaft 13 is extended and has a bearing in said frame 46. Said shaft is provided with a cam 48 which operates upon the reciprocating slide 44 to positively raise and lower the same, thus the trimming device 17 is vibrated up and down. The co-operating trimming device 16 is fixed; said device being in the form of an inclined blade mounted in a suitable recess in the frame 46 and secured therein by a screw 49, see Figure 1. The presser foot is formed with a recess 50 located directly above this movable cutting device 17 and the upper layer of the fabric will be raised by the cutting device, the forwardly projecting blade serving the double function of separating the layers of fabric and co-operating with the fixed cutting device for cutting said lower layer of fabric only. The end cap 51 for closing the end of the work supporting arm has a dovetail connection with the throat plate 52 of the machine and also has a recess to receive the bracket 46 firmly fitting the side edges thereon, as clearly shown in Figure 3.

From the above, it will be apparent that the two fabric sections to be joined may be overlapped and led directly into the machine without turning said edge portions out of the plane of the fabric sections. The cutting devices 14 and 17 will pass between the two fabric sections, raising the upper fabric section from the lower fabric section at spaced lines on which the cutting is to be performed. The cutting device 14 as it reciprocates trims off the edge of the fabric section F¹ and along the line just at the right of the needle 7 and deflects the cut off strip away from the needle, while the cutting device 17 as it reciprocates will trim off the edge of the fabric section F² along the line just to the left of the needle 9 and the shank of this cutting device will deflect the trimmed off strip to the right of the needle. The two independent trimming devices, therefore, cut the respective fabric sections and said fabric sections are cut on

parallel lines, which parallel lines of cutting are within the limits of the stitching mechanism—that is, between the needles 7 and 9, so that the edge portions will be united and the cut edges thereof covered by the stitching threads.

While I have shown the invention as applied to a machine wherein the fabric sections are united by three needles and the cut edges covered, it will be obvious that in certain aspects of the invention, any form of stitching mechanism may be used in connection with my trimming devices which operate to prepare the edge portions of overlapped fabric sections without turning said edge portions out of the plane of the fabric sections—at least, to any appreciable extent. It is also obvious that minor changes in the details of construction and the arrangement of parts may be made without departing from the spirit of the invention, as set forth in the appended claims.

Having thus described my invention, what I claim as new and desire to secure by Letters Patent, is:

1. The combination with feeding mechanism and covering stitching mechanism for feeding and stitching two overlapped fabric sections and covering the edges of the sections; of a trimming mechanism including independent trimming devices located in front of the stitching mechanism, each of said trimming devices having cooperating cutting members located so as to cut the respective edge portions only of the fabric sections said trimming devices being so disposed that the fabric sections are trimmed while the edge portions are overlapped and so that said overlapped trimmed portions will lie within the limits of the covering stitching mechanism.

2. The combination with feeding mechanism and covering stitching mechanism for feeding and stitching two overlapped fabric sections, of a trimming mechanism including independent trimming devices located in front of the stitching mechanism for cutting the respective edge portions only of the fabric sections, whereby said sections as they pass to the stitching mechanism will be overlapped, and said trimming devices being so disposed that said overlapped portions lie within the limits of the covering stitching mechanism.

3. The combination with stitching mechanism including devices for forming covering stitches, and feeding mechanism for feeding two overlapped flat fabric sections to the stitching mechanism, of a trimming mechanism including devices disposed in front of the stitching mechanism for cutting the respective edge portions only of the fabric sections along spaced parallel lines within the limits of the covering stitching mechanism.

4. The combination with stitching mechanism including devices for forming covering stitches, and feeding mechanism for feeding two overlapped flat fabric sections to the stitching mechanism, of a trimming mechanism including devices disposed in front of the stitching mechanism for cutting the respective edge portions only of the fabric sections along spaced parallel lines within the limits of the covering stitching mechanism, the trimming devices operating to deflect the respective trimmed off edges outside of the limits of the covering stitching mechanism. 75
5. The combination with stitching mechanism including devices for forming covering stitches, a work supporting arm, and a feeding mechanism for feeding overlapped fabric sections on to said arm, of a trimming mechanism including trimming devices disposed in front of the stitching mechanism for cutting the respective edge portions only along spaced parallel lines within the limits of the covering stitching mechanism. 80
6. The combination with stitching mechanism including devices for forming covering stitches, a work supporting arm, and a feeding mechanism for feeding overlapped fabric sections on to said arm, of a trimming mechanism including trimming devices disposed in front of the stitching mechanism for cutting the respective edge portions only along spaced parallel lines within the limits of the covering stitching mechanism, said trimming devices operating to deflect the respective trimmed off edge portions outside of the limits of the covering stitching mechanism. 85
7. The combination with a covering stitch forming mechanism including a plurality of needles arranged in a line at right angles to the line of feed, and a feeding mechanism for feeding overlapped fabric sections to the stitching mechanism, of a trimming mechanism including devices for cutting the respective edge portions of the overlapped fabric sections along spaced lines and in advance of said stitching needles, said cutting lines being within the outer needles of the stitching mechanism, whereby the cut edges will be covered by the stitching threads. 90
8. The combination with covering stitching mechanism and a feeding mechanism for feeding overlapped fabric sections, of a trimming mechanism including trimming devices operating to separate said fabric sections and trim the edge portions of said fabric sections along spaced lines, said stitching mechanism including a plurality of needles arranged in a line at right angles to the line of feed and with the outer needles outside of the respective cut edges of the fabric sections, whereby said cut edges may be covered. 95
9. A sewing machine including in combination, a tubular work supporting arm, an overhanging arm, covering stitch forming mechanism, and a trimming mechanism including laterally spaced independently operated trimming devices disposed so as to trim the edges of the fabric sections while said edges are laterally overlapped and so that the overlapped portions of said edges are within the limits of the covering stitches and will be covered thereby. 100
10. A sewing machine including in combination, a tubular work supporting arm, an overhanging arm, covering stitch forming mechanism, and a trimming mechanism including laterally spaced trimming devices disposed so as to trim respectively the edges of the overlapped fabric sections, said trimming devices being disposed so that the cut edges are within the limits of the covering stitches and covered thereby. 105
11. A sewing machine including in combination, a tubular work supporting arm, an overhanging arm, covering stitch forming mechanism, and a trimming mechanism including a pair of co-operating trimming members carried by the overhanging arm, and a pair of co-operating trimming members carried by the work supporting arm, said pairs of trimming members being constructed and disposed so as to operate respectively upon the upper and lower layers of overlapped fabric sections, said pairs of trimming members being laterally spaced and disposed relative to the covering stitching mechanism so that the fabric sections passing from the trimming mechanism will have their edges overlapped and covered. 110
12. A sewing machine including in combination, a tubular work supporting arm, an overhanging arm, covering stitch forming mechanism, a trimming mechanism including laterally spaced pairs of trimming blades, one pair being supported by the overhanging arm and the other pair being supported by the work supporting arm, a presser foot having an opening formed therethrough for the trimming blades carried by the overhanging arm and a recess formed in its underface for the trimming blades carried by the work supporting arm. 115
13. A sewing machine including in combination, a tubular work supporting arm, a looper shaft extending lengthwise of said arm, a looper carried thereby, an overhanging arm, needles carried by said overhanging arm, a trimming blade carried by the work supporting arm and having an overhanging cutting edge, a movable blade co-operating therewith, and means operatively carried by the looper shaft for reciprocating the movable blade. 120
- In testimony whereof, I affix my signature.
ROBERT R. HUGHES, JR. 125