

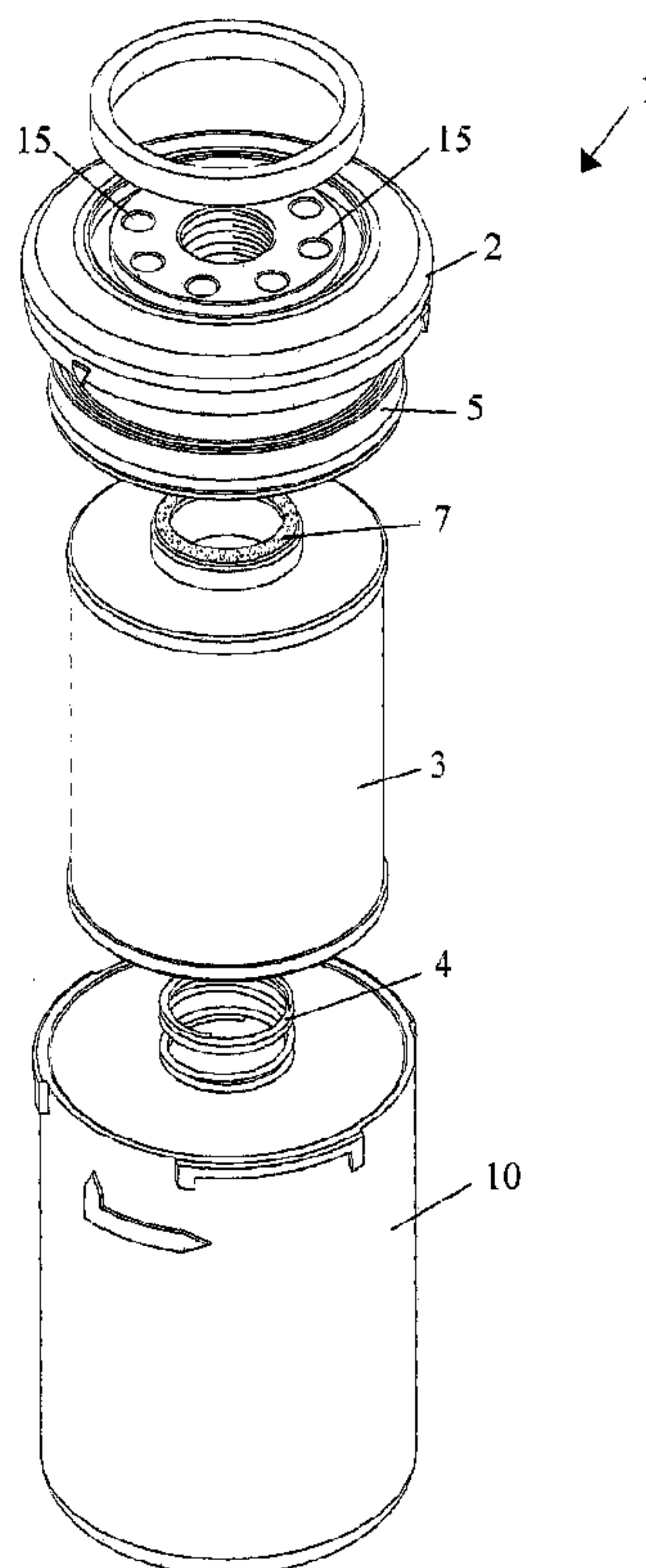

(86) **Date de dépôt PCT/PCT Filing Date:** 2014/05/14
(87) **Date publication PCT/PCT Publication Date:** 2014/11/20
(45) **Date de délivrance/Issue Date:** 2018/03/06
(85) **Entrée phase nationale/National Entry:** 2015/10/21
(86) **N° demande PCT/PCT Application No.:** IB 2014/000724
(87) **N° publication PCT/PCT Publication No.:** 2014/184637
(30) **Priorité/Priority:** 2013/05/15 (IT MI2013U000193)

(51) **Cl.Int./Int.Cl. B01D 35/30** (2006.01),
B01D 27/08 (2006.01)
(72) **Inventeur/Inventor:**
BOLDINI, ERMINIO DONALD, IT
(73) **Propriétaire/Owner:**
FAI FILTRI S.R.L., IT
(74) **Agent:** MACRAE & CO.

(54) **Titre : CONSTRUCTION DE FILTRE A HUILE POUR DES MOTEURS A COMBUSTION INTERNE ET POUR DES MACHINES COMPORTANT DES CIRCUITS OLEODYNAMIQUES**
(54) **Title: OIL FILTER CONSTRUCTION FOR INTERNAL COMBUSTION ENGINES AND FOR MACHINES INCLUDING OLEODYNAMIC CIRCUITS**



(57) **Abrégé/Abstract:**

An oil filter construction, for internal combustion engines or hydraulic machines, comprises a flange to which a container body adapted to contain a filtering cartridge is coupled, said container body being coupled to said flange by coupling means allowing to separate said body from said cartridge to dispose of said two elements separately, said coupling means comprising a bayonet type closure.

(12) INTERNATIONAL APPLICATION PUBLISHED UNDER THE PATENT COOPERATION TREATY (PCT)

(19) World Intellectual Property
Organization
International Bureau(10) International Publication Number
WO 2014/184637 A1(43) International Publication Date
20 November 2014 (20.11.2014)

- (51) International Patent Classification:
B01D 35/30 (2006.01) *B01D 27/08* (2006.01)
- (21) International Application Number:
PCT/IB2014/000724
- (22) International Filing Date:
14 May 2014 (14.05.2014)
- (25) Filing Language: Italian
- (26) Publication Language: English
- (30) Priority Data:
MI2013U000193 15 May 2013 (15.05.2013) IT
- (71) Applicant: FAI FILTRI S.R.L. [IT/IT]; Strada Provinciale Francesca, 7, I-24040 Pontirolo Nuovo (BG) (IT).
- (72) Inventor: BOLDINI, Erminio Donald; Via Dante, 33, I-20010 Boffalora sopra Ticino (MI) (IT).
- (74) Agent: CICOONA, Franco; Ufficio Internazionale Brevetti Dott. Prof. Franco Cicogna, Via Visconti di Modrone, 14/A, I-20122 Milano (IT).
- (81) Designated States (*unless otherwise indicated, for every kind of national protection available*): AE, AG, AL, AM, AO, AT, AU, AZ, BA, BB, BG, BH, BN, BR, BW, BY, BZ, CA, CH, CL, CN, CO, CR, CU, CZ, DE, DK, DM, DO, DZ, EC, EE, EG, ES, FI, GB, GD, GE, GH, GM, GT, HN, HR, HU, ID, IL, IN, IR, IS, JP, KE, KG, KN, KP, KR, KZ, LA, LC, LK, LR, LS, LT, LU, LY, MA, MD, ME, MG, MK, MN, MW, MX, MY, MZ, NA, NG, NI, NO, NZ, OM, PA, PE, PG, PH, PL, PT, QA, RO, RS, RU, RW, SA, SC, SD, SE, SG, SK, SL, SM, ST, SV, SY, TH, TJ, TM,

[Continued on next page]

(54) Title: OIL FILTER CONSTRUCTION FOR INTERNAL COMBUSTION ENGINES AND FOR MACHINES INCLUDING OLEODYNAMIC CIRCUITS

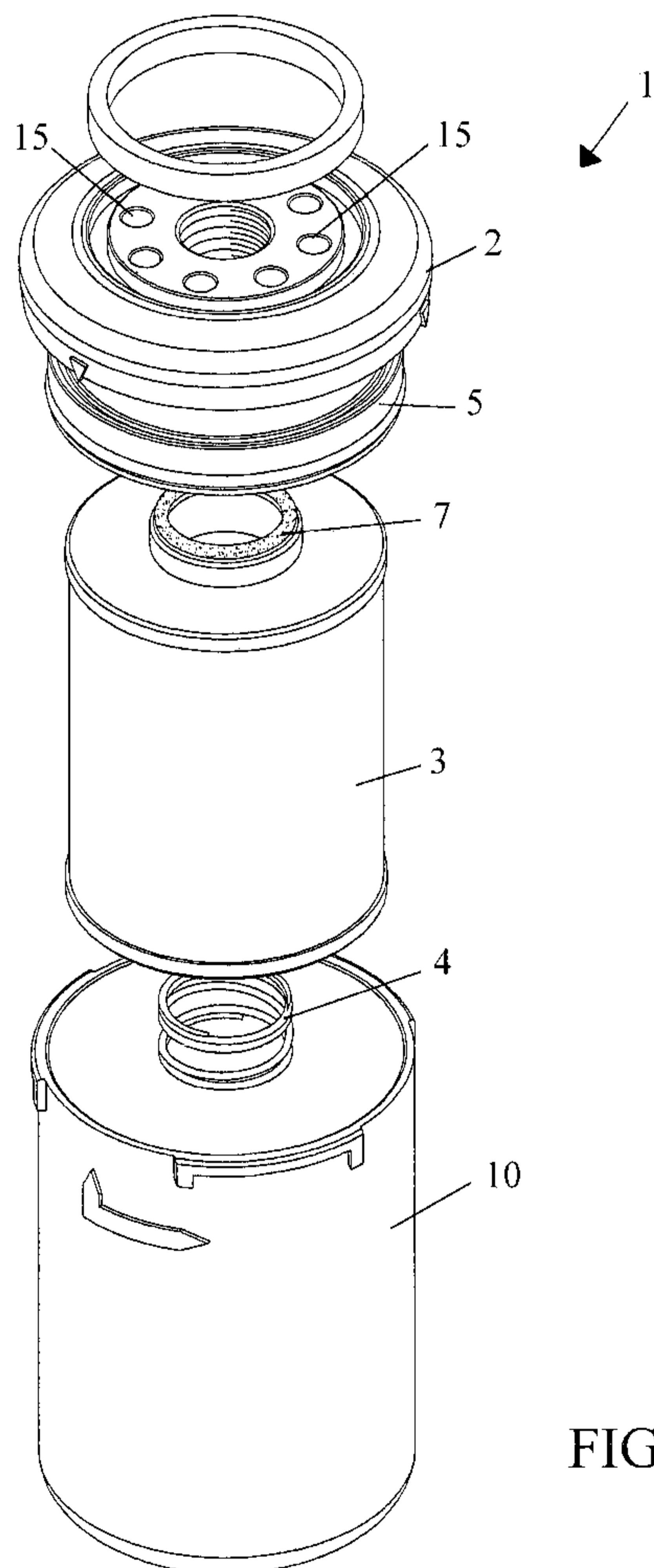

FIG. 1

(57) Abstract: An oil filter construction, for internal combustion engines or hydraulic machines, comprises a flange to which a container body adapted to contain a filtering cartridge is coupled, said container body being coupled to said flange by coupling means allowing to separate said body from said cartridge to dispose of said two elements separately, said coupling means comprising a bayonet type closure.



WO 2014/184637 A1

WO 2014/184637 A1

TN, TR, TT, TZ, UA, UG, US, UZ, VC, VN, ZA, ZM, ZW.

SM, TR), OAPI (BF, BJ, CF, CG, CI, CM, GA, GN, GQ, GW, KM, ML, MR, NE, SN, TD, TG).

(84) Designated States (*unless otherwise indicated, for every kind of regional protection available*): ARIPO (BW, GH, GM, KE, LR, LS, MW, MZ, NA, RW, SD, SL, SZ, TZ, UG, ZM, ZW), Eurasian (AM, AZ, BY, KG, KZ, RU, TJ, TM), European (AL, AT, BE, BG, CH, CY, CZ, DE, DK, EE, ES, FI, FR, GB, GR, HR, HU, IE, IS, IT, LT, LU, LV, MC, MK, MT, NL, NO, PL, PT, RO, RS, SE, SI, SK,

Declarations under Rule 4.17:

— *as to the applicant's entitlement to claim the priority of the earlier application (Rule 4.17(iii))*

Published:

— *with international search report (Art. 21(3))*

OIL FILTER CONSTRUCTION FOR INTERNAL COMBUSTION ENGINES AND FOR MACHINES INCLUDING OLEODYNAMIC CIRCUITS

5

BACKGROUND OF THE INVENTION

The present invention relates to an oil filter construction, for internal combustion engines and in general for machines operating based on an oil flow.

As is known, an oil filter is conventionally used in internal combustion engines and in many machines operating for collecting metal wastes and impurities of various nature conveyed through the oil flow in a regular operation of those devices.

The present oil filter construction is designed for being screwed on and off and is so designed as to allow a replacement of its filtering element only, without the need of also replacing the oil filter housing.

A prior oil filter comprises a metal filter body which may be directly threaded on the engine basement or on a hydraulic machine and containing a filtering element usually made of a paper material.

Such an oil filter is affected by the great drawback that it cannot be easily disposed of.

SUMMARY OF THE INVENTION

Accordingly, the aim of the present invention is to provide such an oil filter construction for internal combustion engines and other machines, which may be easily disposed of.

Within the scope of the above aim, a main object of the invention is to provide such an oil filter construction which may be used in replacement of conventional metal filters threaded or screwed to an engine basement or block and other hydraulic machines.

Another object of the present invention is to provide such an oil filter construction which may be made of easily available elements and materials and which, moreover, is very competitive from a mere economic standpoint.

Yet another object of the present invention is to provide such an oil filter construction which, owing to its specifically designed structural features, is very reliable and safe in operation.

According to one aspect of the present invention, the above mentioned
5 aim and objects, as well as yet other objects, which will become more apparent hereinafter, are achieved by an oil filter construction, for internal combustion engines and hydraulic machines, characterized in that said oil filter construction comprises a flange to which a container body may be associated for containing a filtering cartridge, said body being coupled to said flange by coupling means al-
10 lowing to disengage the filter body from the filtering cartridge thereby allowing to dispose of said filtering cartridge only.

BRIEF DESCRIPTION OF THE DRAWINGS

15 Further characteristics and advantages of the present invention will become more apparent hereinafter from the following disclosure of a preferred, though not exclusive, embodiment of the invention, which is illustrated, by way of an indicative but not limitative example, in the accompanying drawings, where:

Figure 1 is an exploded perspective view showing the oil filter construction
20 according to the present invention;

Figure 2 is an elevation view of the oil filter construction, in a use condition thereof;

Figure 3 is a longitudinal cross-sectioned elevation view of the oil filter construction; and

25 Figure 4 is another longitudinal cross-sectioned elevation view showing the filter construction with the filter body being removed from the flange.

DESCRIPTION OF THE PREFERRED EMBODIMENTS

30 With reference to the number references of the above mentioned figures, the oil filter construction according to the present invention, which has been generally indicated by the reference number 1, comprises a flange 2 to which a filter body 10 designed for containing a filtering cartridge 3 may be coupled.

The filter body 10 is coupled to said flange 2 by quick coupling means comprising a bayonet type of female closure.

Between the flange 2 and the top or upper edge of the filter body 10, a centering ring 5 is arranged, said centering ring being fixed to said flange by an annular sealing rib 11 preferably made of a sealing epoxy material.

Said centering ring 5 comprises an annular recess housing an O-ring 8 providing a sealing connection with the surface of the upper edge of the body 10, which is arranged, in a use condition, between the centering ring 5 and flange 2.

Said flange 2 comprises an annular lug element 12 for engaging an end piece 13 of the filtering cartridge 3, through an interposition of an annular gasket 7 providing a sealed connection between said filtering cartridge 3 and flange 2.

In a use condition, that is with the body 10 being latched or coupled to said flange 2, a pressure spring 4, arranged between a bottom of the body 10 and said cartridge 3, urges said cartridge against said flange 2, thereby pressing the annular gasket 7.

As shown, the annular lug element 12 of said flange 2 comprises a threaded hole 14 which may be engaged by a threaded fitting provided in a conventional internal combustion engine for attachment of a standard type of oil filter.

More specifically, the threaded hole 14 allows the engine filter attachment or fitting, not shown in the figures, to communicate with the inner portion of the filtering cartridge 3.

Thus, filtered oil will pass between the inner portion of the filtering cartridge 3 and the outer portion thereof, inside the body 10.

The outer portion of the filtering cartridge 3 communicates with the engine basement or block or other hydraulic machine by suitable radially extending holes 15 formed in said flange 2, which comprises a sealing gasket 6, of a standard type, providing a sealed coupling of the oil filter construction with the engine basement or hydraulic machine it is applied to.

According to the invention, the oil filter construction may be mounted either in an internal combustion engine or a hydraulic machine in replacement of a conventional screw-on/off oil filter.

Thus, when the filtering cartridge must be replaced, it will be sufficient to

disengage the body 10 from the flange 2 and remove the cartridge 3 which may be easily disposed of or, if desired, also washed and reused.

It has been found that the invention fully achieves the intended aim and objects.

5 In fact, the invention has provided an oil filter construction allowing to separately dispose of the filter body and filtering cartridge, the latter being contaminated by oil.

In practicing the invention, the used materials, as well as the contingent size and shapes can be any, according to the requirements.

CLAIMS:

1. An oil filter construction, for an internal combustion engine or a machine operating based on an oil flow, said oil filter construction comprising a flange to which a container body adapted to contain a filtering cartridge is coupled, said container body being coupled to said flange by coupling means allowing to separate said body from said cartridge to dispose of said cartridge only, said coupling means being quick coupling means comprising a bayonet type or female closure, **characterized in that** between said flange and a top edge of said body a centering ring, fixed to said flange by an annular rib of a sealing material is arranged, **that** said centering ring comprises an annular recess in which an O-ring is engaged providing a sealing coupling with a surface of the top edge of said body which, in a use condition, is arranged between said centering ring and flange, **that** said flange comprises an annular lug element adapted to engage an end piece of said filtering cartridge through an interposition of an annular gasket providing a sealing coupling between said cartridge and flange, and **that** said cartridge comprises an outer cartridge portion communicating with said engine or machine through radially extending holes formed in said flange, said flange comprising a sealing gasket, of a standard type, providing a sealed connection of said filter construction with said engine or machine said filtering is applied to.

2. An oil filter construction, according to claim 1, **characterized in that**, in a use condition, that is with said body coupled to said flange, a pressing spring, arranged between a bottom of said body and said cartridge, urges said cartridge against said flange thereby pressing said annular gasket.

3. An oil filter construction, according to claim 1, **characterized in that** said flange annular lug element comprises a threaded hole which may be engaged by a threaded fitting of said internal combustion engine or machine for attachment of a standard type of oil filter, said threaded hole allowing said attachment to communicate with an inner portion of the filtering cartridge and an outer portion of said filtering cartridge, thereby filtered oil will pass between said inner and outer portions of said filtering cartridge.

4. An oil filter construction, according to any one of claims 1 to 3, wherein the sealing material is an epoxy sealing material.

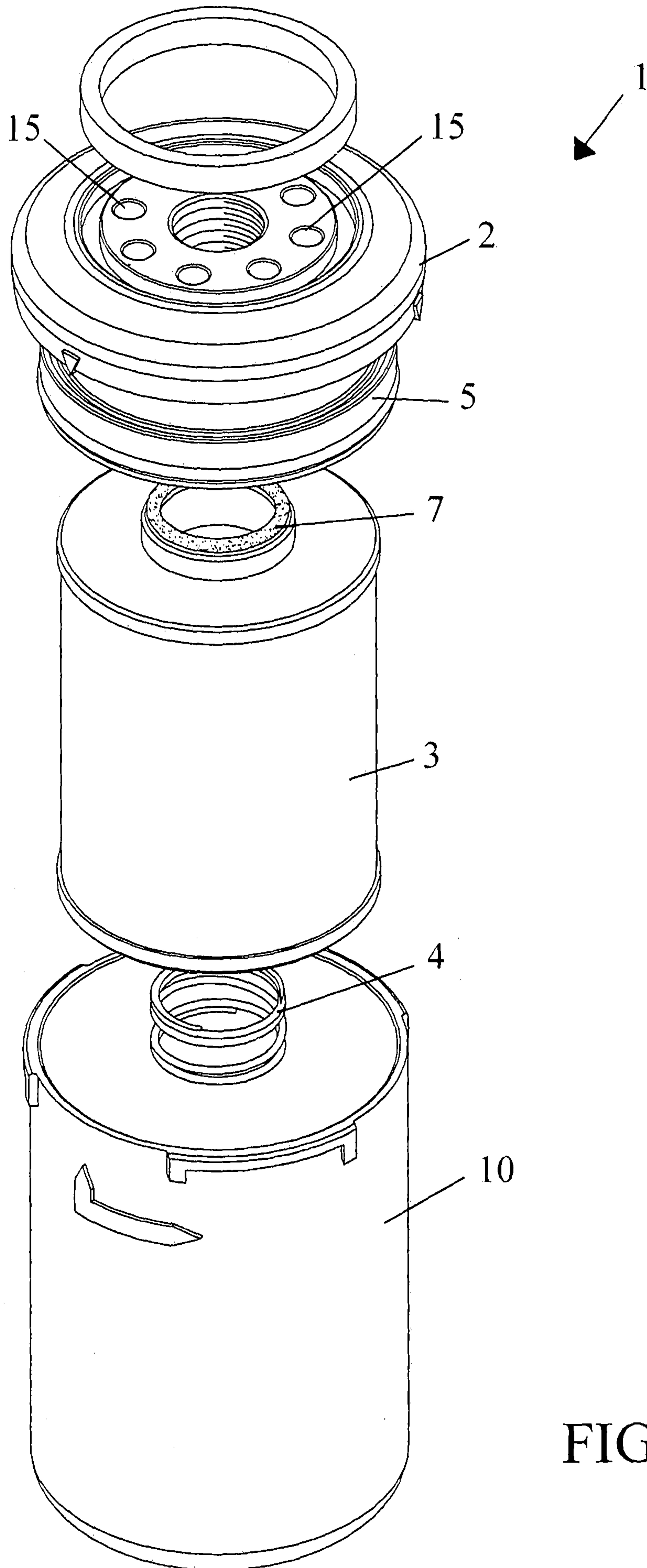

FIG. 1

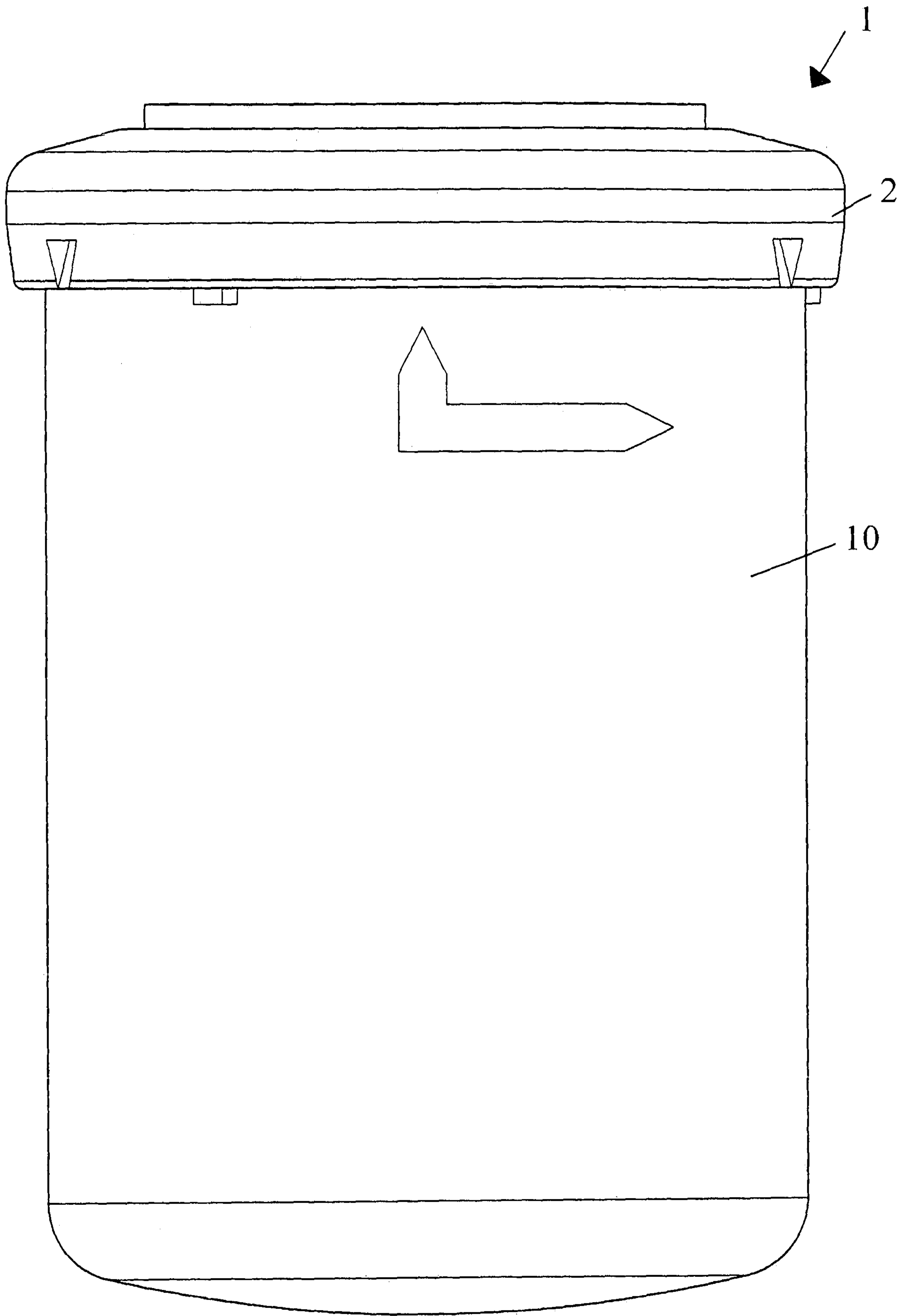

FIG. 2

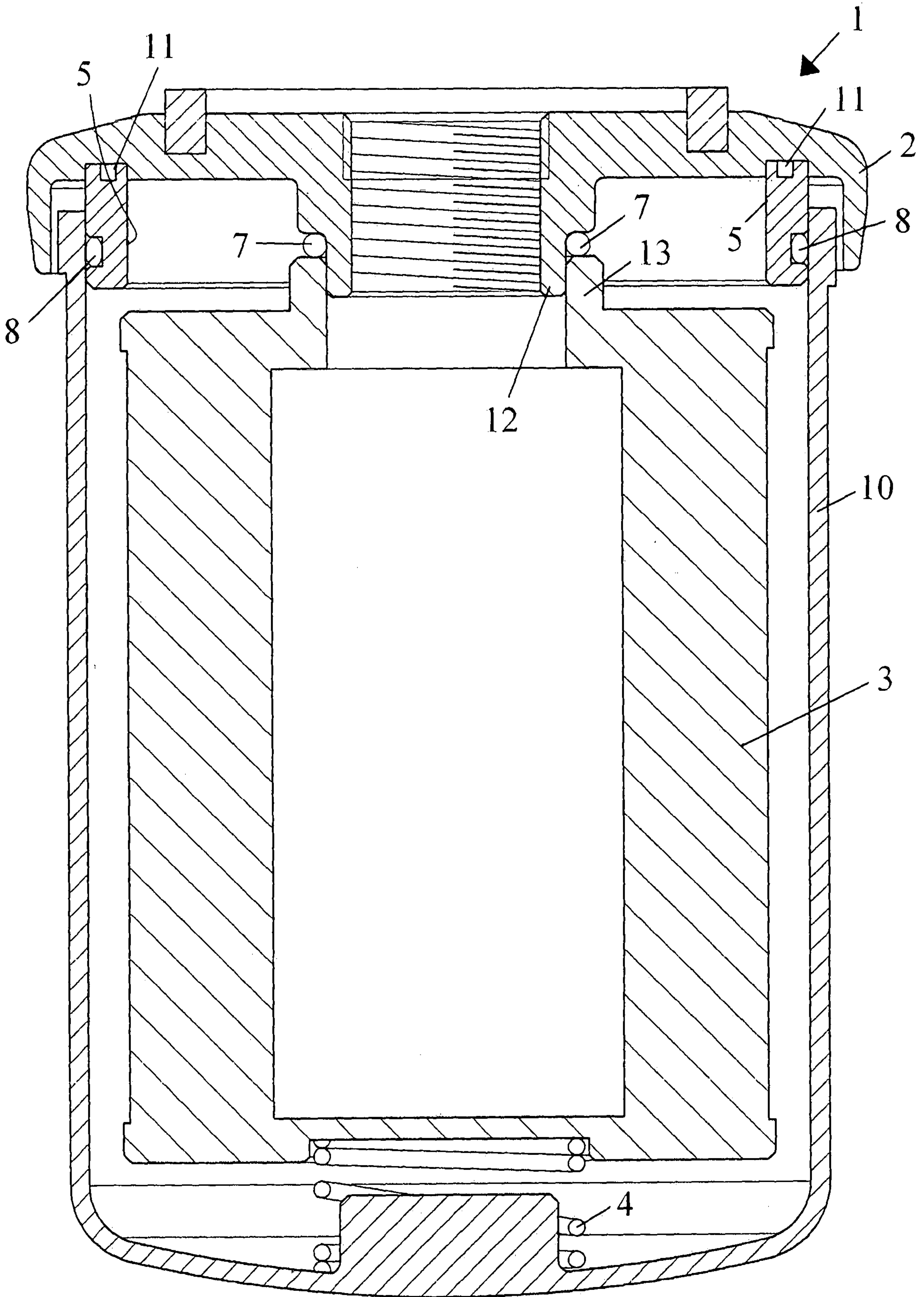

FIG. 3

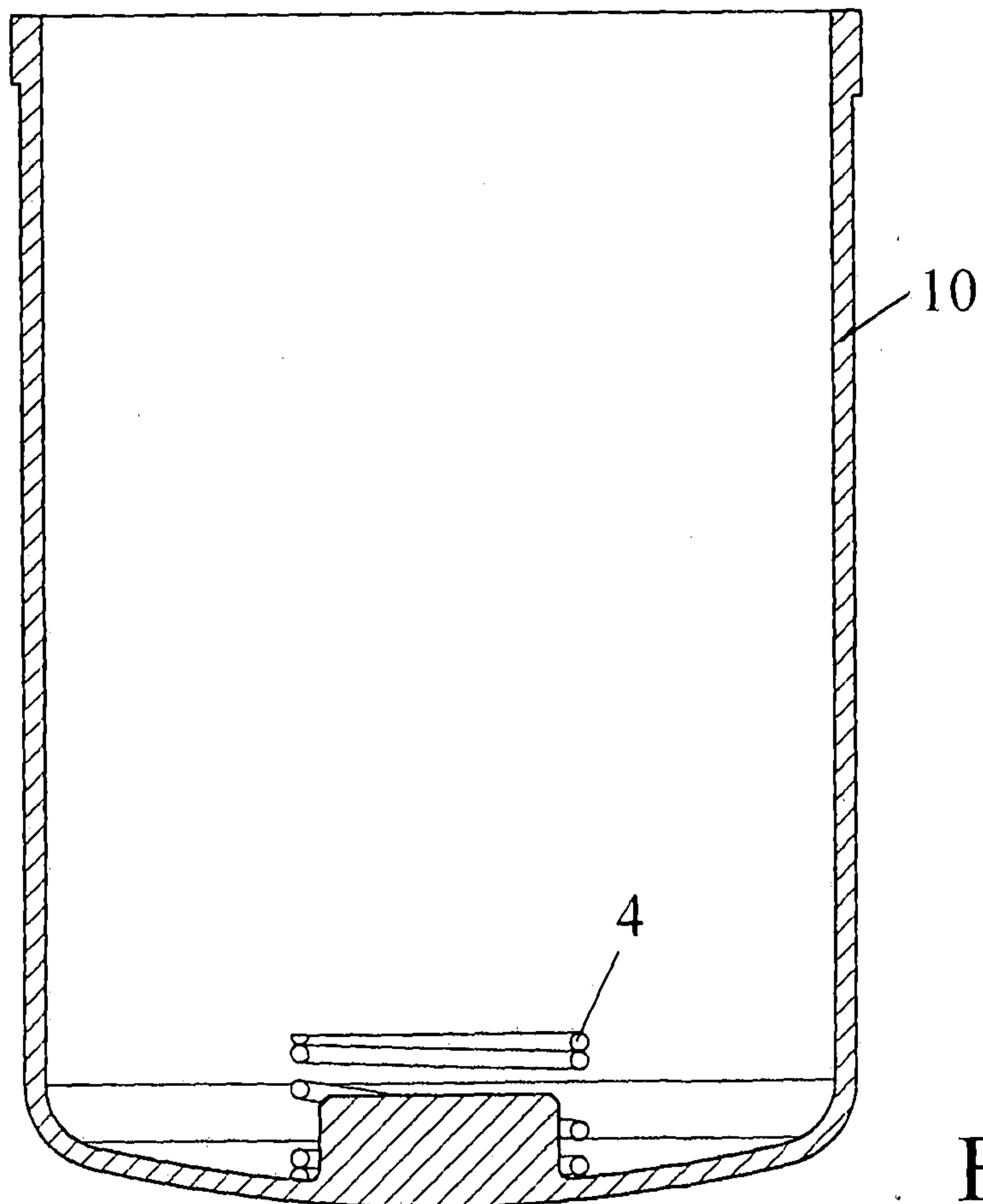
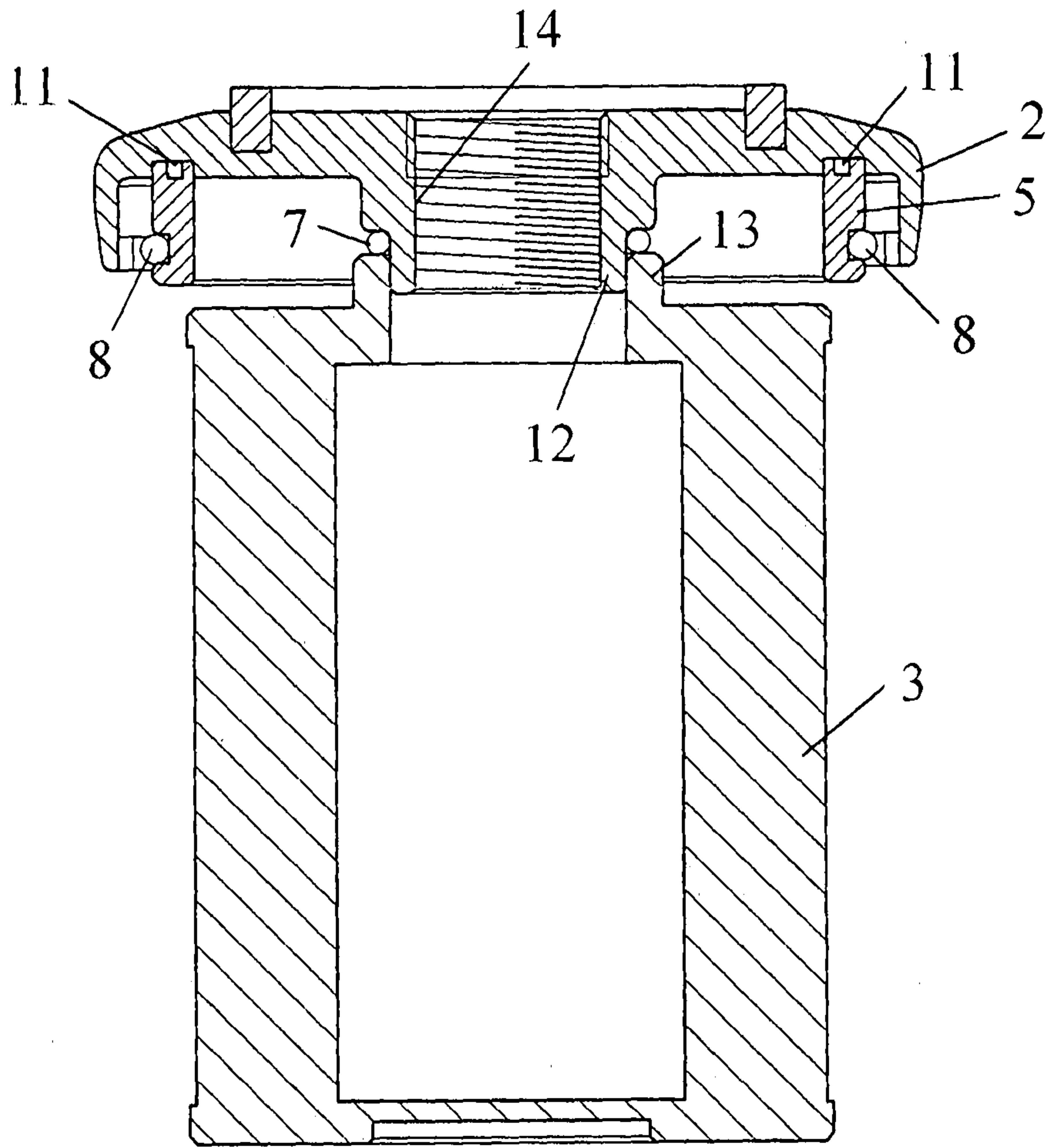

FIG. 4

