

Oct. 29, 1935.

E. H. TAYLOR

2,018,904

CIRCUIT BREAKER

Filed July 11, 1933

2 Sheets-Sheet 1

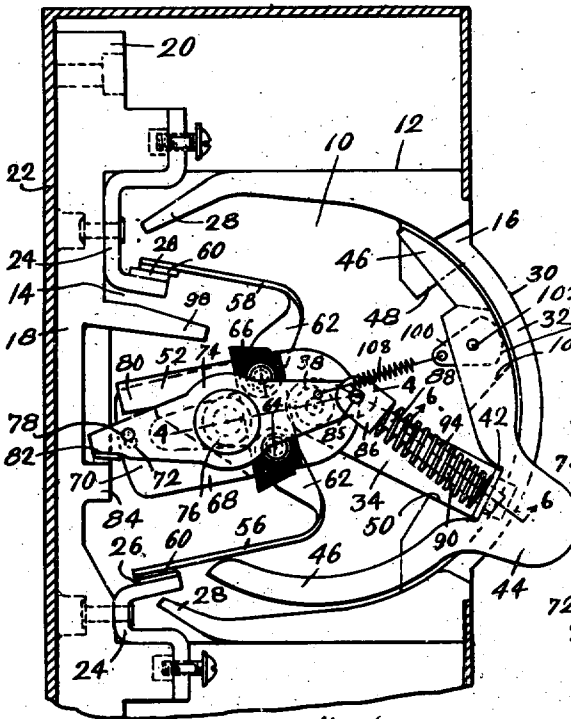

Fig. 1.

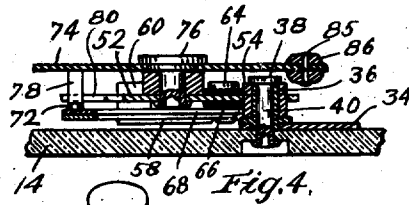

Fig. 4.

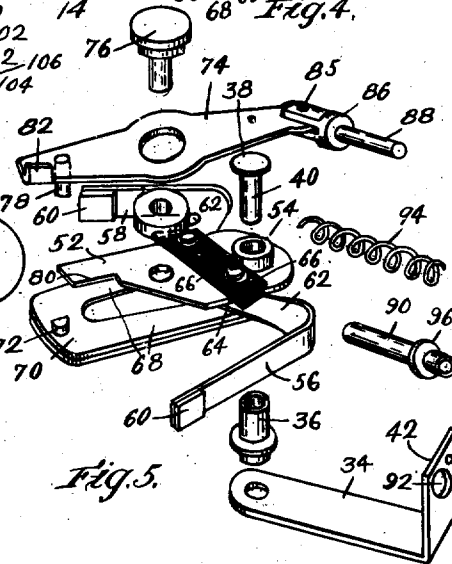

Fig. 5.

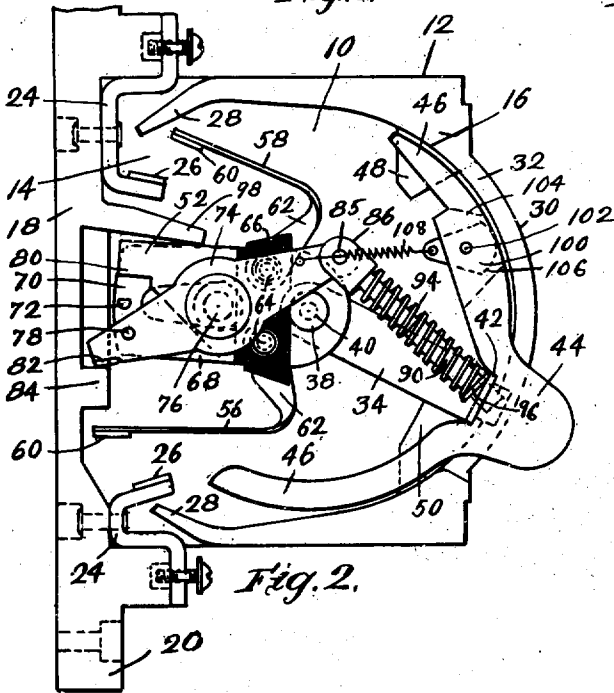

Fig. 2.

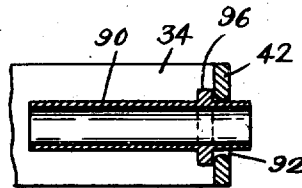

Fig. 6.

Inventor,
Elmer H. Taylor
Greenwood atty

Oct. 29, 1935.

E. H. TAYLOR

2,018,904

CIRCUIT BREAKER

Filed July 11, 1933

2 Sheets-Sheet 2

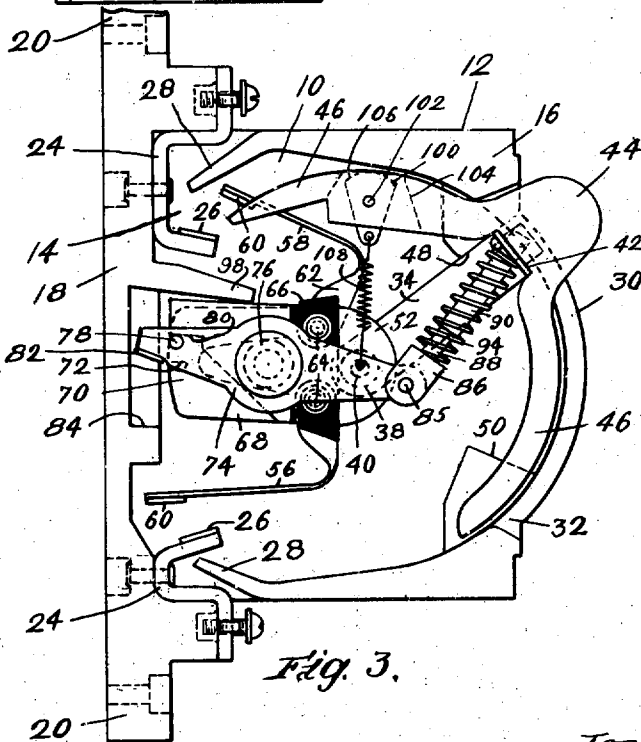
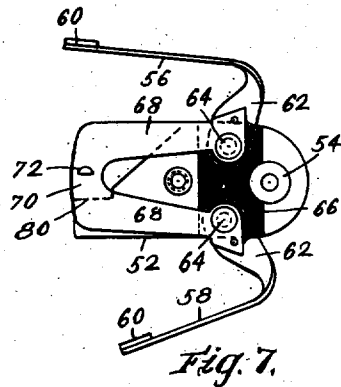
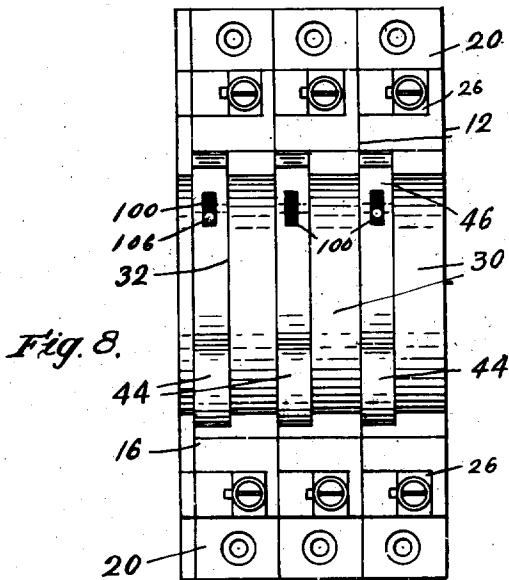

Inventor:
Elmer H. Taylor
by *Freemond*
att'y

UNITED STATES PATENT OFFICE

2,018,904

CIRCUIT BREAKER

Elmer H. Taylor, Newburyport, Mass., assignor
to The Chase-Shawmut Company, Newbury-
port, Mass., a corporation of Massachusetts

Application July 11, 1933, Serial No. 679,901

23 Claims. (Cl. 200—116)

This invention relates to switches and circuit breakers of the type adapted to control light circuits and the circuits of relatively small powered apparatus such as motors and the like.

One of the objects of the present invention is an improved form of circuit breaker that is operated manually by an actuating handle and is moved rapidly into open and closed positions independently of a corresponding movement of the handle and also is moved into open circuit position independently of movement of the handle by an overload current.

The present switch is particularly adapted for gang mounting in an enclosing box and a further object of the invention is an improved construction that lends itself readily to gang mounting and is of small and compact dimensions and wherein the side of one switch in the gang constitutes the cover for the open side of the adjacent switch.

A yet further object is the provision of a circuit breaker of the type above set forth having overload tripping means including a thermostatic member that constitutes a component part of the movable switch member and is in circuit between the contact terminals thereof.

Another object of the invention is the provision of an overload-trip circuit breaker having overload responsive tripping means therefor and an over-center spring for manually operating the switch between open and closed positions and wherein the over-center spring also constitutes the means for moving the switch into open circuit condition when it is tripped upon overload.

A further object of the invention is the provision of a circuit breaker having a pivotally mounted bridging member and an actuating member therefor that is pivoted to the bridging member and also is latched thereto against independent pivotal movement by an overload responsive mechanism, combined with means acting on the actuating member to move it and the bridging member between switch open and closed positions, the bridging mechanism being so arranged that when the actuating member is unlatched from the bridging member it operates through its pivotal connection therewith to move the bridging member into switch open position.

Another object of the invention is the provision of an indicating device operated by movements of the aforesaid actuating member to give a visual indication of the electrically tripped condition of the breaker.

A yet further object is generally to improve the construction and operation of circuit breakers.

Fig. 1 is a plan view of a circuit breaker embodying the present invention, the breaker being illustrated in closed position.

Fig. 2 is a view similar to Fig. 1 but with the parts thereof in electrically tripped open circuit position.

Fig. 3 is a view similar to Fig. 1 but with the parts thereof in manually operated open circuit position.

Fig. 4 is a sectional detail taken along line 10—4 of Fig. 1.

Fig. 5 is an exploded view of the operating mechanism.

Fig. 6 is a sectional detail of the guide tube for the over-center spring guide rod taken along line 15—6 of Fig. 1.

Fig. 7 is a plan view of the movable bridging member.

Fig. 8 is a front elevation of a gang of circuit breakers of Fig. 1.

The circuit breaker herein illustrated as embodying the present invention has its operative parts enclosed within a chamber or compartment 10 of an enclosing casing 12, the casing 12 being composed of suitable insulating material having 25 an end wall 14 which closes one end of the chamber and a peripheral side wall 16 which surrounds the chamber, the other end of the chamber being open. The casing also has a bottom wall 18 which is provided with lugs 20 by which the casing can be attached to a suitable support as the back wall 22 of an enclosing box or housing. The bottom casing wall 18 also carries stationary contact supports 24 which terminate within the chamber 10 in contact members 26. The side wall 16 of the casing at said contact supports is provided with inturned sections 28 that are disposed between the contact members and the openings through which the contact supports pass and function as barriers or baffles to hinder the discharge of flame when the circuit breaker opens under an abnormally high current. The side wall of the casing has an arcuate front wall 30 which, adjacent the open side of the chamber 10, is recessed to provide a notch 32 through which the operating handle of the breaker is extended. The breaker mechanism is located within the chamber or compartment 10 within the open end thereof. When a gang of breakers are mounted together in side by side relation as illustrated in Fig. 8 the back wall 14 of one casing overlies and constitutes a cover for the open chamber of the adjacent casing as illustrated in Fig. 8.

The operating handle of the breaker includes an arm 34 which is disposed upon the inner face

of the bottom wall 14 of the casing and is pivoted upon a spacing sleeve 36 located upon and under the head 38 of a stud or rivet 40 which is fixed in the wall 14 and upstands thereabove within the chamber 10. The arm 34 has an upturned portion 42 at its outer end which is secured to the inner face of an insulating operating handle 44 that extends through the slot 32. Said handle 44 has arcuate extensions 46 on opposite sides thereof which closely underlie the opening 32 to close the opening in all positions of the operating handle. The casing is provided with stop lugs or abutments 48 and 50 respectively which define respectively the switch open and closed positions of the operating handle.

The movable bridging member comprises a flat plate 52 that can be composed of either insulating material or metal and as here shown as being composed of metal. Said plate has a hub 54 fixed therein which is journaled upon the spacing sleeve 36 of the rivet 40. Said plate carries resilient contact supports 56 and 58 which as here shown are comprised of flat resilient strips that are disposed on opposite sides of the supporting plate 52 in generally parallel relation with said plate and with each other and are terminated at their free ends in contact members 60 that cooperate with separate ones of the stationary contact members 26. The contact supports 56 and 58 have reflexed portions 62 that are directed inwardly toward said supporting plate 52 and are twisted at right angles to the plane of the contact supporting portion of the strips and are fixed to the plate 52 by suitable means as rivets 64 and are insulated from said plate 52 by suitable insulating means as the insulating plates 66. The contact supports are electrically connected by a thermal latch plate that is traversed by the current passing through the switch and is movable between switch open and closed positions with the bridging member, which includes the supporting plate 52, and is adapted to operate on excessive currents to effect the overload opening of the switch. The thermal latch comprises a U-shaped plate of thermostatic material, which can consist of two metals having dissimilar coefficients of thermal expansion secured together back to back. The thermostatic plate is formed or provided with generally parallel spaced legs 68 that are connected at their similar ends by the integral connecting part or member 70, the free ends of the legs being secured upon the ends 62 of the contact supports 56 and 58 in electrically conducting relation therebetween by the rivets 64. The contact supports and the thermal latch thus constitute in effect an integral current conducting structure and with the supporting plate 52 comprises the bridging member of the breaker. The connecting member 70 of the thermal latch is provided with an upstanding detent 72 in its upper face, or the face that confronts the open end of the compartment 10, and the thermal member is adapted to be reflexed or warped downwardly when sufficiently heated by an abnormal current traversing it to effect the open circuit movement of the bridging member.

The bridging member is provided with an actuating member therefor comprising a plate or arm 74 which overlies the head 38 of the rivet 40 and is pivotally connected to the supporting plate 52 by a rivet or other means 76 which is connected with the plate 52 at one side of its pivotal support on the rivet 40. Said actuating member 74 is provided with a detent 78 which normally engages the detent 72 of the thermal latch for mov-

ing the bridging member into closed circuit position and engages a projection 80 of the supporting plate 52 that is spaced back of said thermal latch detent 72 for moving the bridging member manually into circuit open position. Thus, under the manual operation of the breaker, the bridging member and actuating member are in effect locked together against independent movement. The projection 80 is spaced from the latch detent 72 by a distance substantially greater than the thickness of the detent 78 so that there is a substantial amount of lost play or movement of the detent 78 in passing from the engagement of the projection 80 into the engagement of the detent 72. This lost motion is for the purpose of insuring a positive and rapid action of the bridging member between its two positions even though the operating handle is moved very slowly in a corresponding direction, as will be apparent hereinafter. The end of the actuating member adjacent the detent 78 projects beyond said detent and constitutes a stop and is provided with an upturned stop member 82 which when the breaker is tripped electrically comes up against an abutment 84 projecting from the end wall 18 of the casing. When the breaker is opened and closed manually, however, said stop member 82 does not engage the abutment 84 but is positioned slightly out of engagement therewith in the closed circuit position of the breaker as is illustrated in Fig. 1. Said actuating member 74 extends in the opposite direction or away from the detent 78 and across the pivot rivet 40 for the actuating member and has a pivotal connection 86 with a clevis 88. Said clevis is fixed to one end of a guide rod 90 that is freely axially movable in a guide tube 92, see especially Fig. 6, loosely disposed in an aperture 92 of the upturned end 42 of the operating arm 34 for pivotal movement thereon. An over-center compression spring 94 encircles said guide rod and tube and has its ends bearing against the clevis 88 and against outstanding flange 96 of said guide tube thereby exerting a substantial pressure upon said actuating member 74 and the handle tending when the switch is closed to hold the bridging member and handle in corresponding switch closed positions, and, when the switch is open, to hold the parts in switch open position and acting to move the bridging member rapidly from one to the other position when the handle is moved sufficiently toward its corresponding position. When the breaker is open it is closed by moving the operating handle from its switch-open position sufficiently toward its switch-closed position to move the over-center spring over the line passing through the pivot 88 of the clevis 88 and the pivot 40 of the movable switch member. This movement causes the spring to exert a pressure on the actuating member to rotate it about its own pivot 76 and free from the bridging member in a counterclockwise direction, see Fig. 3, until the detent 78 has passed from engagement with the supporting plate 52 and into engagement with the detent 72 of the bridging member, thereby carrying the spring further and being definitely across center. The spring continues to act in the same direction, but with increased force on the actuating member and the bridging member to cause the bridging member to move into circuit-closed position. Upon movement of the operating handle in the reverse operation the reverse operation takes place and the bridging member is moved into open circuit position.

It will be noted that in the above described manual operation of the switch the actuating

member 74 is latched to the bridging member so that both, in effect, move as one unit between switch open and closed positions and the actuating member is not free for independent pivotal movement in any manner that effects a switching operation. When, however, an overload current traverses the closed switch and heats the thermal latch sufficiently to cause it to warp downwardly to detach the detent 72 from engagement with the detent 78 the actuating member is then free for independent movement about its pivot 76. The over-center spring urges the actuating member for rotation in a counterclockwise direction, Fig. 1, which movement brings the abutment member 82 thereof against the fixed abutment 84 of the casing. The engagement of the abutments prevents further rotation of the actuating member in this manner. The over-center spring, however, still exerts pressure on its end of the actuating member and thereby tends to cause it to rock or fulcrum on the fixed abutment 84. This action causes the actuating member to act as a lever on its pivot 76 and hence causes the bridging member to rotate in a clockwise direction about its pivot 40 into an open circuit position as illustrated in Fig. 2, the open circuit position being defined by an abutment 98 of the casing which is engaged by the edge of the supporting member 52. Thus the freeing of the actuating member from its latched connection with the bridging member and its movement against and about the fulcrum 84 shifts the application of force of the over-center spring from one side to the other of the center of the pivot 40 for the bridging member and hence causes the spring to effect the opening movement of the bridging member without, however, any physical movement of the spring across the center. The actuating member is re-latched to the bridging member by a movement of the operating handle into open circuit position in which position the force of the over-center spring rotates the actuating member in a clockwise direction, restoring the detent 78 into position behind the detent 72 of the latch member of the bridging member. The mechanism thus arranged is simple in construction and is positive and certain in its operation.

It will be noted that the pressure between the detents 72 and 78 is exerted mainly in the plane of the thermal latch or at right angles to the warping thereof so that there is little opposition to the warping and the thermal member thus can be sensitive to overloads.

Mechanism is provided for giving a visual indication of the electrically tripped condition of the breaker. Said mechanism includes an indicating segment or target 100 which is pivoted on a pin 102 carried by the operating handle and disposed in a slot 104 of one of the arcuate arms 46 of the handle so that its arcuate surface is disposed in a position to be visible when the handle is in circuit closed position. The segment bears a suitable indicating mark, which can be a color, on a portion 106 of its surface that, when the breaker is in manually opened or closed condition, is concealed behind a portion of the arcuate arm 46 but is adapted to be exposed when the breaker is tripped electrically. The segment 100 is connected through a tensile spring 108 with the actuating member 74 at a suitable point intermediate its pivotal point and its pivotal connection 85 with the clevis 86 and preferably over the axis of the pivot 40. When the breaker is manually opened and closed the tensile spring 108

is always under such tension as to keep the axis of the spring in line with the pivot 102 of the segment and the pivot 40. When, however, the actuating member is tripped and moves into a position to effect the electrically tripped opening of the breaker the line of pull of the spring 108 is shifted in such direction as to cause the segment 100 to be rotated sufficiently to expose the marked portion 106 thereof and thereby to indicate visually that the switch has been opened electrically. Thus the shifting of the position of the actuating member when electrically tripped is caused to indicate the tripped condition of the breaker.

I claim:

1. A circuit breaker comprising cooperating stationary and movable contact members, and actuating mechanism for the movable contact member having a latch connection therewith and an over-center spring urging said movable contact member in one direction when latched to said actuating mechanism and in the opposite direction when unlatched therefrom.

2. A circuit breaker comprising cooperating stationary and movable contact members, actuating mechanism for the movable contact member having a breakable connection therewith and an over-center spring urging said movable contact member in one direction when connected to said actuating mechanism and in the opposite direction when disconnected therefrom, and overload responsive means controlling said breakable connection.

3. A circuit breaker comprising cooperating stationary and movable contact members, operating mechanism for said movable contact member comprising an actuating member having a latch connection with said movable contact member, and an over-center spring acting in one position thereof on said actuating member to move said movable contact member in a circuit closing direction and acting through said unlatched actuating member to move said movable contact member in a circuit opening direction.

4. A circuit breaker comprising a pivotally mounted contact member, an actuating member therefor having a pivotal and also a latch connection with said movable contact member, and an over-center spring acting on said actuating member to move it and said movable contact member from a switch open to a switch closed position and from a switch closed position to a switch open position and when said actuating member is unlatched to move said movable switch member from switch closed to switch open position.

5. A circuit breaker comprising a pivoted switch member, an actuating member therefor having a pivotal connection with said switch member, and a latch connection therewith which normally holds said actuating member against operative movement about its pivot, means including an over-center spring acting on said actuating member to move it and said switch member between open and closed positions, and means providing a fulcrum engageable with said unlatched actuating member to change the point of effective application of the force of said spring on said switch member to move it into an open circuit position.

6. A circuit breaker comprising a pivoted switch member, means including an over-center spring to move said switch member between open and closed positions, and electro-responsive mechanism for permitting the shifting of the application of the force of said spring on said movable 75

switch member from one side to the other of the pivot thereof for effecting the opening movement of said switch member.

7. A circuit breaker comprising a pivoted switch member, an actuating member having a pivotal and also a latch connection with said movable switch member, an over-center spring acting on said actuating member on the side of the pivot of said pivoted switch member opposite its pivotal connection with said actuating member, and a fulcrum against which the unlatched actuating member is pressed by said spring to move said switch member in a circuit controlling direction.

8. A circuit breaker comprising a pivoted switch member, an actuating member having a pivotal and also a latch connection with said movable switch member, an over-center spring acting on said actuating member on the side of the pivot of said pivoted switch member opposite its pivotal connection with said actuating member, and a fulcrum against which the unlatched actuating member is pressed by said spring to move said switch member in a circuit controlling direction and means for moving said over-center spring over center.

9. A circuit breaker comprising a pivoted switch member, an actuating member therefor having a pivotal connection therewith at one side of the pivotal center of said movable switch member and also having a latch connection therewith so arranged that said actuating and switch members are constrained for pivotal movement as a unit about the pivot of said pivotal switch member, an over-center spring acting on said actuating member on the other side of the pivot of said switch member, means for moving said spring over-center to move the switch member between switch open and closed positions, and a fulcrum disposed in position to be engaged by said unlatched actuating member to effect the open circuit movement of said movable switch member.

10. A circuit breaker comprising a pivoted switch member movable between switch open and closed positions, a pivoted actuating member for said switch member having a lost motion connection therewith, and an over-center spring acting on said actuating member to move it and said movable switch member between switch open and closed positions and to move said actuating member from one end to the other of its lost motion connection at the time said over-center spring passes over center.

11. A circuit breaker comprising a pivoted switch member having a pair of spaced abutments, a pivoted actuating member for said movable switch member having a detent that is positioned loosely between said abutments, and an over-center spring acting on said actuating member to move it and said switch member between switch open and closed positions, said abutments and detents being so arranged that said detent passes from the engagement of one abutment to that of the other during the movement of said spring over center.

12. A circuit breaker comprising a movable switch member including a pivoted supporting plate, contact members carried thereby, a thermal latch carried by said plate and constituting the electrical connection between said contact members, an actuating member for said movable switch member having a normally latched engagement with said thermal latch, and an over-center spring acting on said actuating member for moving said movable switch member when

latched into switch closed position and when unlatched into switch open position.

13. A circuit breaker comprising a pivoted switch member, an actuating member therefor having a latch connection with said switch member, means including an over-center spring for moving said actuating and switch members between switch open and closed positions, and thermal means carried by said switch member for breaking said latch connection and effecting the circuit opening movement of said movable switch member by said over-center spring.

14. A circuit breaker comprising a pivoted switch member including a thermostatic plate fixed to said switch member at one end and free to warp at the other end, contact members carried by said movable switch member and connected electrically in series with said thermostatic plate, an actuating member pivoted to said movable switch member and also having a latch connection therewith through said thermostatic plate which normally restrains said actuating member from operative movement about its pivot, and means including an over-center spring for moving said actuating member and switch member conjointly between switch open and closed positions and said unlatched switch member independently of said actuating member between switch closed and open positions.

15. A circuit breaker comprising a pivoted switch member including contact members, a thermostatic plate connected electrically between said contact members and fixed at one end and free to warp at the other end, an actuating member pivoted to said movable switch member having a latch connection with said thermostatic plate, an over-center spring acting on said actuating member on the side of the pivot of said switch member opposite the pivot of said actuating member, means for moving said over-center spring over center to move said actuating and switch members conjointly between open and closed circuit positions, and means providing a fulcrum for said unlatched actuating member disposed to cause said over-center spring to act through the pivot of said actuating member with said movable switch member to move the latter from closed circuit to open circuit position.

16. A circuit breaker comprising a movable switch member including a pivoted plate, contact members carried by said plate, a U-shaped thermostatic plate having its legs fixed to said plate and connected electrically between said contact member, an actuating member overlying said movable switch member and having a pivotal connection therewith at one side of the pivot of said switch member and also having a latch connection therewith controlled by said thermostatic plate, an over-center spring acting on said actuating member on the side of the pivot of said switch member opposite the pivotal connection between it and said actuating member, means for moving said over-center spring over center to open and close said switch, and means providing a fulcrum adapted to be engaged by said unlatched actuating member in the closed condition of the breaker to effect the circuit opening movement of said movable switch member.

17. In a circuit breaker comprising a switch member movable between switch open and closed positions, and indicating means movable from a switch closed position into a position which indicates the electrically opened condition of the switch, the combination therewith of an actuating member movable conjointly with said switch

member between open and closed positions and movable independently of said movable switch member when said switch member is electrically actuated for circuit opening movement, and means connecting said indicating means and said actuating member operative upon such independent movement of said actuating member to effect movement of said indicating member into its position which indicates the electrically opened condition of the switch.

18. In a circuit breaker comprising a switch member movable between open and closed positions, an indicator for denoting the electrically opened condition of the switch, an actuating member having a connection with said movable switch member and movable conjointly therewith between open and closed positions when connected therewith, an operating handle, an over-center spring connecting said handle and actuating member for moving it between switch open and closed positions, overload responsive means for effecting the overload opening of the switch, the combination therewith of an arrangement wherein said connection is breakable and said spring is operative when said connection is broken to effect independent movement of said actuating and movable switch members; said indicator being carried by said handle and being responsive to movement of said independent movement of said actuating member to be moved thereby into a position indicating the overload responsive movement of said movable switch member.

19. In a circuit breaker comprising a pivoted switch member, an actuating member therefor, an operating handle, an over-center spring connecting said handle and said actuating member for moving it and said movable switch member conjointly between open and closed circuit positions, overload responsive means for effecting movement of said movable switch member into open circuit position, the combination therewith of a pivotal and also a latch connection between said actuating and switch members, said overload responsive means being arranged to break said latch connection, said spring being thereupon arranged to effect movement of said actuating member about its own pivot, a pivoted open circuit indi-

cating member, a tensile spring connected with said indicating member and also with said actuating member about in line with the pivot of said pivoted switch member, said actuating member in its independent movement thereof moving away from the pivot of said switch member and hence effecting the pivotal movement of said indicating member. 5

20. A circuit breaker as defined in claim 19 wherein said operating handle and said pivoted switch member are concentrically pivoted and wherein said pivoted indicating member is carried by said handle. 10

21. A circuit breaker comprising a pivoted switch member, an actuating arm for said switch member having a pivotal bearing thereon, a lock between said switch member and actuating arm, tripping means for said lock, a fulcrum engaged by said unlocked arm, and an over-center spring acting on said arm, the points of engagement of said arm with said spring and fulcrum being so positioned with respect to the location of said pivotal bearing between said arm and switch member that said spring acting through said latched arm urges said movable switch member in one direction and acting through said unlatched arm urges said movable switch member in the opposite direction. 15 20 25

22. A circuit breaker comprising a pivoted switch member, an actuating arm pivoted to said switch member eccentrically of the pivot thereof, a latch connection between said actuating arm and switch member, a fulcrum for said unlatched actuating arm, and an over-center spring acting on said actuating arm. 30 35

23. An electric switch comprising a movable contact member, an arm movable in opposite directions for moving said contact member between open and closed positions, means providing two fulcrums for said arm, a spring acting in the same direction to move said arm in one direction about one fulcrum and in the opposite direction about the other fulcrum, and current-responsive means which determines which one of said two fulcrums about which said arm shall rock. 40 45

ELMER H. TAYLOR.