

March 3, 1959

M. J. STAM
APPARATUS FOR CONVERTING LIQUIDS, SOLUTIONS, EMULSIONS,
SUSPENSIONS, AND THE LIKE INTO DRY POWDERS
Filed Dec. 21, 1954

2,875,823

FIG. 1

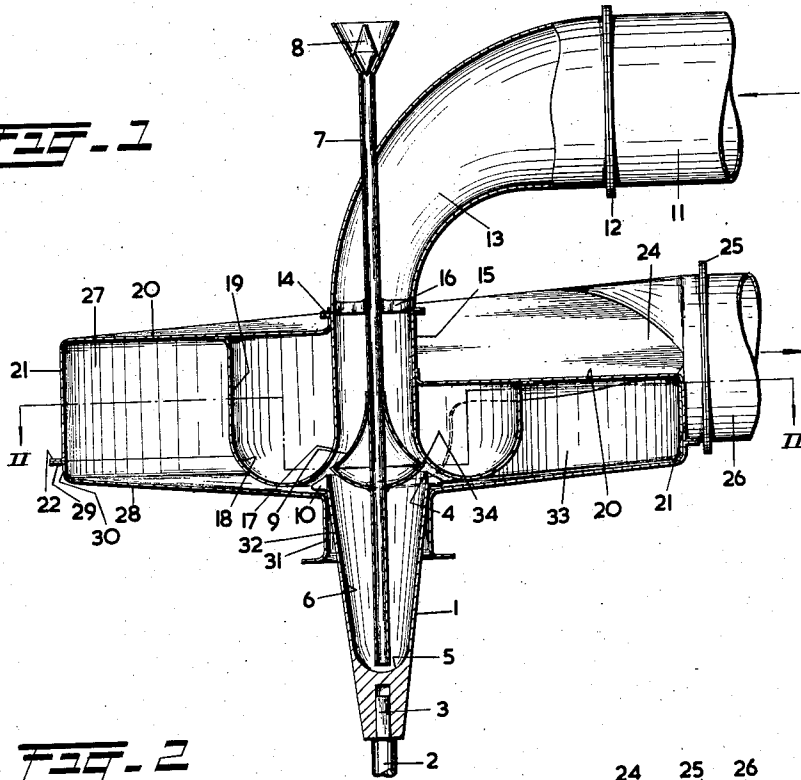
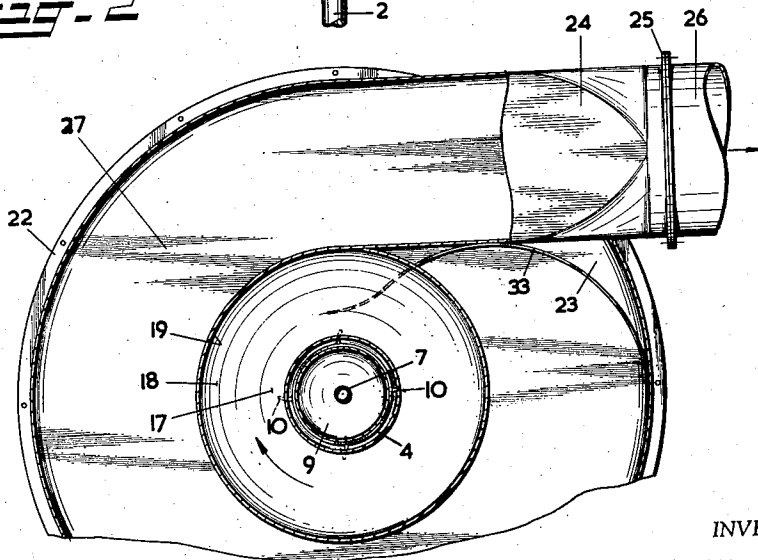

FIG. 2



INVENTOR

MARTINUS J. STAM

BY

Taulmin & Taulmin

ATTORNEYS

1

2,875,823

APPARATUS FOR CONVERTING LIQUIDS, SOLUTIONS, EMULSIONS, SUSPENSIONS, AND THE LIKE INTO DRY POWDERS

Martinus Joannes Stam, Rotterdam, Netherlands, assignor to Rubber-Latex-Poeder-Compagnie N. V., Amsterdam, Netherlands, a company of The Netherlands

Application December 21, 1954, Serial No. 476,796

Claims priority, application Netherlands December 28, 1953

4 Claims. (Cl. 159-4)

My invention relates to an apparatus for converting liquids, solutions, emulsions, suspensions and like media into dry powders.

It is an object of this invention to improve such apparatus so that an extremely fine dry powder with a great uniformity of particle size is obtained.

It is a further object of this invention to attain the above object with a simple and reliable apparatus.

It has been proposed to obtain dry powders from liquids or the like by introducing the liquids into a cup-shaped atomizer, centrally disposed in a casing and being rotated so as to project the liquid as a thin film outwards into a flow of gas, which atomizes the liquid in said film and entrains it while further drying it into a fine powder.

My invention improves such known proposals. In this respect I propose according to the present invention to embody such an apparatus in combination with a casing, atomizer means centrally disposed therein, said atomizer means comprising a vertically disposed rotary cup having an open top, a sharp upper rim around said open top, a substantially concave closed bottom portion and a straight substantially conical side wall intermediate said open top and said bottom portion, said open top being of a diameter larger than said bottom portion and smaller than the depth of said cup, a shaft for rotating said cup about its central cone axis, a supply conduit for the medium to be atomized, which supply conduit enters the cup through said open top, ends directly above the bottom and is disposed coaxially with said shaft, means defining a narrow annular slot formed along said upper rim of said cup between the latter and said casing, said slot opening from the cup into the interior of said casing and through which slot said medium is dischargeable from the cup into the casing, when said medium atomized, and a gas conduit formed around said open cup top, said narrow annular slot opening into said conduit also, and which conduit is of a narrowest cross sectional area in the vicinity of said open cup top and gradually increases in cross sectional area from said narrow annular slot to attain the cross sectional area of said discharge tube. The gas conduit will of course be made to guide a suitable drying gas such as hot air.

With an apparatus according to the present invention it is, for example, possible to atomize a latex film with a thickness when leaving the atomizer cup of 0.3 to 10μ. After drying, very fine rubber particles are obtained, viz., of 0.1 to 3μ. Such favorable results have never before been obtained with such simple and small cost involving apparatus.

Other objects and advantages of the invention will become apparent from the further description thereof in connection with the accompanying drawings, wherein

Figure 1 shows a vertical cross-section of the apparatus according to the invention.

Figure 2 is a horizontal cross-section of the above drier apparatus along the line II—II in Figure 1.

2

A cup-shaped atomizer 1 is carried by a driving shaft 2, which is connected to the atomizer by a square head 3 engaging in a square hole in the bottom of the atomizer. The atomizer 1 is rotatable by shaft 2 about a vertical axis and is shaped as a body of revolution generated around said axis. It has an open top, a sharp upper rim 4 about said open top, a substantially hemispherical closed bottom portion 5 and conical part 6 widening upwardly and connecting the bottom portion 5 while continuously changing into said portion to the upper rim 4. The depth of the atomizer 1 is larger than the diameter of the said rim 4.

A stationary vertical supply conduit 7 for medium to be atomized is positioned with its axis in the axis of rotation of the atomizer cup 1. Said conduit 7 is open at top and bottom ends has at its top an internal fairing 8 constituted by two cones with joined bases and supported in the upper conical part of the conduit by struts supporting the lower cone.

The conduit 7 extends downwards into the atomizer cup 1 to a short distance from the bottom thereof. In the proximity of the top of the atomizer cup 1 the conduit 7 is provided with a guiding member 9 shaped as a body of revolution about the vertical axis of the conduit 7 and filling the space in the top surface of the atomizer cup so that a small annular space is left between the rim 4 and this guiding member. Said guiding member is secured to the conduit 7 and its shape in vertical cross-section is about a downwardly widening hyperboloid in the upper part and a spherical lower part, joined together at their largest diameter, as will be clear from the drawing.

The atomizer cup 1 is provided on its outer surface in the proximity of the rim 4 but a short distance below said rim with four blades 10 curved outwardly against the direction of rotation of the cup, as will immediately be clear from Figure 2 of the drawings, and distributed evenly about the periphery of the cup 1.

A gas inlet conduit 11 is provided and extends in a horizontal direction towards the vertical axis of the conduit 7 for the liquid medium. Its flanged end is bolted at 12 to a similar flange of a duct elbow 13 curving downwardly and of gradually diminishing diameter, being bolted at 14 with its flanged lower end to a similar flange of a vertical gas conduit 15. Four evenly spaced struts 16 in the lower part of said elbow 13 support the conduit 7 so that when mounting or removing the elbow 13 the conduit 7 with guiding member 9 is simultaneously mounted and removed respectively.

Said vertical gas conduit 15 diverges downwardly in its lower part 17 and so passes into a part 18 in the shape of the lower half of a torus with a circular cross-section and symmetrical about the vertical axis of conduit 7, conduit 15 and atomizer cup 1. The outer side of said toroidal part 18 changes into a vertical cylindrical wall 19, continuing in an outwardly extending wall 20, which latter at its outer periphery changes into a downwardly directed cylindrical wall 21 terminating in a flange 22. The wall part 20 is not situated in a plane perpendicular to the vertical axis of the cup 1, etc., but is positioned at a varying height, being the smallest at 23 in Figure 2 and gradually increasing in the sense of clockwise rotation as seen in Figure 2, so that it is much higher in the left part of Figure 1 than in the right part of Figure 1, and gradually changing into a discharge tube 24 of circular cross-section terminating in a flange 25, to which a discharge duct 26 is bolted with a similar flange.

The parts 15, 17, 18, 19, 20, 21 and 22 constitute the greater part of a volute casing with a volute discharge passage 27 therein. Said passage is limited at

3

its lower surface by a lower casing part 28 being a dish-shaped body with a flange 29 at the upper end of its outer upturned peripheral part 30. Casing part 28 is symmetrical with respect to the common vertical axis of conduit 7 and cup 1.

In its centre, casing part 28 extends inwardly towards the cup 1 below the blades 10 thereon and is bent downwardly below said blades to change into a downwardly extending cylindrical duct 31 open at its lower end. Between said duct 31 and the cup 1 there is left a small annular gap 32.

A guiding wall 33 is provided between top and bottom of the casing in the narrowest part 23 thereof. Said wall 33 is secured, e. g., by welding, to the lower casing part 28 with its lower edge. Its upper edge has a shape so that it almost contacts the upper casing part along the walls 21, 20, 19 and 18 thereof. The wall 33 is generated by straight vertical lines and its shape in a horizontal direction clearly appears from Figure 2 of the drawings.

As seen from the drawings the gas passage through conduit 15 decreases downwardly in annular cross-sectional area until it has reached its smallest area at the greatest diameter of guiding member 9, where a narrow annular slot 34 is formed.

Past this slot the gas passage again increases in area to change continuously into the discharge casing with volute passage 27.

The operation of the above apparatus will now be described.

Drying gas, e. g., hot air, is introduced through gas supply conduit 11 and flows through elbow 13 down through vertical gas conduit 15. The guiding member 9 guides the gas outwardly within the lower part 17 of gas conduit 15, so that the gas flows downwards and radially outwards as a small annulus through the narrow annular slot 34 radially outwards to passage 27 in the casing.

Liquid medium to be treated, e. g., latex, is introduced in the upper part of conduit 7, is caused to flow down in this conduit evenly and continuously by fairing 8 and flows out from the lower end of conduit 7 right above the bottom portion 5 of cup 1. Said cup is rotated by shaft 2 in the direction of the arrow in Figure 2. The liquid medium is fed in such a quantity and the speed of rotation of cup 1 is chosen so high that an extremely thin film of said medium is formed in the cup 1. Said film flows upwards in the cup and leaves it at the sharp upper rim 4, where it flows almost exactly radially outwards into the narrow, annular slot 34. The drying gas, which flows almost without rotation in inlet conduit 11, is caused to rotate in vertical gas conduit 15 by the action of the blades 10 on the cup 1 and by the fact that the gas leaving the apparatus flows through volute passage 27 in the casing to discharge tube 24, 26, so that the incoming gas begins to rotate in the same direction before it has reached the blades 10. In passing to the narrow annular slot 34 the gas is accelerated considerably owing to its rotation and to the decreasing flow passage downwardly along the guiding member 9.

It will be clear from the above and from the drawings that the gas flowing through annular slot 34 engages the liquid film projected outwardly from rim 4 while substantially flowing in the same direction as said film, said film flowing horizontally outwards and said gas flowing at an angle of about 40° to the horizontal.

It has appeared that in this way a very fine powder is made from the liquid medium instantaneously and that the powder obtained is not only extremely fine but also to a considerable extent uniform in dimension and perfectly dry. Said powder is discharged with the gases through volute passage 27 in the discharge casing and outlet tube 24.

The suction generated by the blades 10 also causes the

4

inflow of ambient air upwardly through the small annular gap 32 between duct 31 and atomizer cup 1. This air cools the atomizer cup. Heating of this cup is further prevented by the fact that the cup 1 is largely located outside the casing and further parts of the apparatus.

The guiding member 9 not only guides the drying gas but also prevents it from flowing into the atomizer cup 1, so that premature drying of the liquid film in said cup by said gas is prevented.

The guiding wall 33 prevents powder, which is not yet entirely dry, to escape to the outlet 24, 26. To this end said guiding wall 33 causes gas and liquid film, being transferred to powder, in that part of the periphery of the narrow annular slot 34 which is close to the outlet 24, 26, to pass through the entire volute passage 27 in the casing before leaving the apparatus through the outlet 24, 26.

As the liquid leaving the atomizer cup 1 is spread out radially outwards after leaving upper rim 4 and as the gas flows substantially in the same direction when engaging said liquid film, agglomeration of fine droplets, into which the film breaks in this area, is prevented so that there are no coarser particles formed in the powder.

If the liquid medium is a solution, suspension or the like, the liquid constituent which is not transferred into powder, such as the solvent or the water in a suspension or emulsion is vaporized and discharged together with the gas.

The gas flow not only prevents the liquid particles from sticking together, but also prevents said particles from reaching the wall of the lower part 17 of vertical gas conduit 15. The supply of gas, the action of blades 9 and the shape of the apparatus is such that the gas has a sufficiently high speed in the narrow annular slot 34 to prevent this. Preferably the gas speed is equal to or higher than the speed of the liquid particles in their zone of first contact.

I claim:

1. In an apparatus for converting liquids, solutions, emulsions, suspensions and the like media into dry powders, the combination of an annular casing, a discharge tube on the perimeter of said casing, atomizer means centrally disposed in said casing and comprising a vertically positioned rotatably mounted cup having an open top and located in the center of said annular casing, the said cup having a substantially concave closed bottom portion, and substantially straight conical walls intermediate the open top and the closed bottom portion, with said open top having a diameter larger than said bottom portion and smaller than the depth of the cup, a shaft for rotating said cup about its central axis, a supply conduit for the medium to be atomized coaxial with said shaft and entering the open top of said cup to terminate short of said cup bottom portion, guiding means in the center of said annular casing and spaced above said cup rim to form a first narrow annular slot with said cup rim which first slot opens into said casing, and a gas conduit within the center of said annular casing and flaring outwardly just outside of said cup rim and said guiding means to form a second narrow annular slot with said guiding means for the passage of gases from said conduit into said casing whereby said first narrow annular slot opens into said gas conduit and said second slot, so that atomized liquid thrown out of said cup over the rim thereof is discharged through said second narrow slot into said casing, said gas conduit having a narrow cross-section in the vicinity of said open cup top and gradually increasing in cross-sectional area to attain the cross-sectional area of said discharge tube.

2. An atomizer as described in claim 1, further comprising blades for rotating the drying gas, said blades being mounted on the outside of said side walls of said rotary cup adjacent said opening thereof.

5

3. In an apparatus for converting liquids, solutions, emulsions, suspensions and the like media into dry powders, the combination of an annular casing, a discharge tube on the perimeter of said casing, atomizer means centrally disposed in said casing and comprising a vertically positioned rotatably mounted cup having an open top and located in the center of said annular casing, the said cup having a substantially concave closed bottom portion and substantially straight conical walls intermediate the open top and the closed bottom portion with said open top having a diameter larger than said bottom portion and smaller than the depth of the cup, a shaft for rotating said cup about its central axis, a supply conduit for the medium to be atomized coaxial with said shaft and entering the open top of said cup to terminate short of said cup bottom portion, guiding means in said annular casing above said rotatably mounted cup and terminating above said cup rim to form a first narrow annular slot with said top rim which first slot opens into said casing, and a gas conduit within the center of said annular casing and flaring outwardly just outside of said cup rim and said guiding means to form a second narrow annular slot with said guiding means for the passage of gases from said conduit into said casing whereby said first narrow annular slot opens into said gas conduit and said second slot so that atomized liquid thrown out of said cup over the rim thereof is discharged through said second narrow slot into said casing, said gas conduit having a narrow cross-section in the vicinity of said open cup top and gradually increasing in cross-sectional area to attain the cross-sectional area of said discharge tube.

4. In an apparatus for converting liquids, solutions, emulsions, suspensions and the like media into dry powders, the combination of an annular casing, a discharge tube on the perimeter of said casing, atomizer means centrally disposed in said casing and comprising a vertically positioned rotatably mounted cup having an open top and located in the center of said annular casing, the

6

said cup having a substantially concave closed bottom portion and substantially straight conical walls intermediate the open top and the closed bottom portion with said open top having a diameter larger than said bottom portion and smaller than the depth of the cup, a shaft for rotating said cup about its central axis, a supply conduit for the medium to be atomized coaxial with said shaft and entering the open top of said cup to terminate short of said cup bottom portion, a substantially conical guiding member having its apex above said cup and opening outwardly toward the direction of said cup to terminate short of said cup rim to form a first narrow annular slot therewith which slot opens into said casing, and a gas conduit within the center of said annular casing and flaring outwardly just outside of said cup rim and said guiding means to form a second narrow annular slot with said guiding means for the passage of gases from said conduit into said casing whereby said first narrow annular slot opens into said gas conduit and said second slot so that atomized liquid thrown out of said cup over the rim thereof is discharged through said second narrow slot into said casing, said gas conduit having a narrow cross-section in the vicinity of said open cup top and gradually increasing in cross-sectional area to attain the cross-sectional area of said discharge tube.

References Cited in the file of this patent

UNITED STATES PATENTS

30	1,330,218	Rieber -----	Feb. 10, 1920
	1,636,317	Nyrop -----	July 19, 1927
	1,796,982	Culter -----	Mar. 17, 1931
	1,853,682	Hechenbleikner -----	Apr. 12, 1932
	1,952,308	Bowen -----	Mar. 27, 1934
	2,002,252	Stam -----	May 21, 1935
35	2,047,699	MacLachlan -----	July 14, 1936
	2,415,527	Peebles -----	Feb. 11, 1947