

C. H. JACKSON.  
Railroad Safety-Switch Apparatus.

No. 223,516.

Patented Jan. 13, 1880.

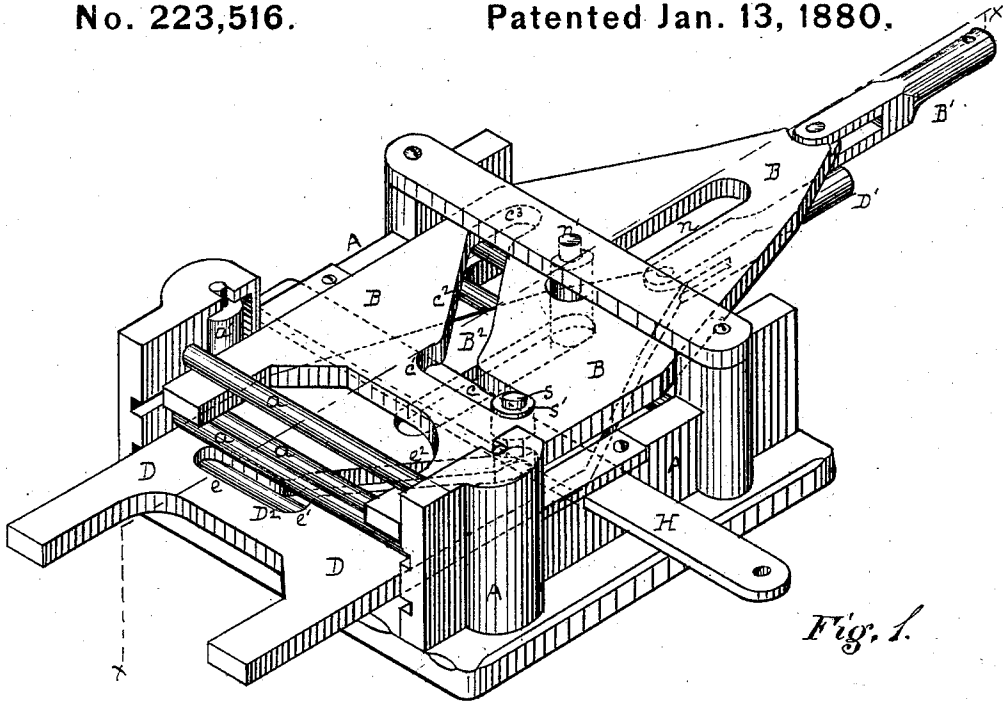

Fig. 1.

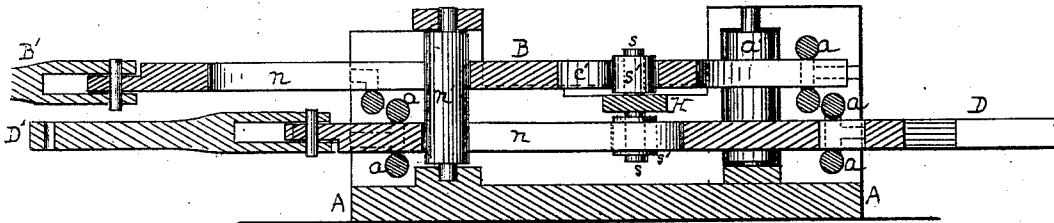

Fig. 2.

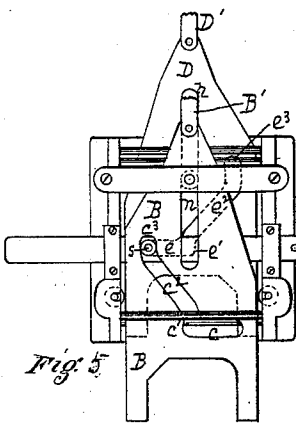

Fig. 3

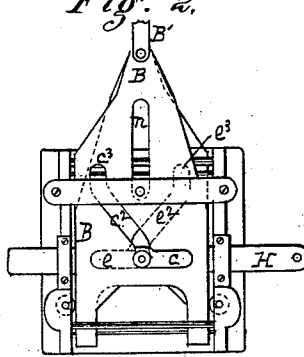

Fig. 4

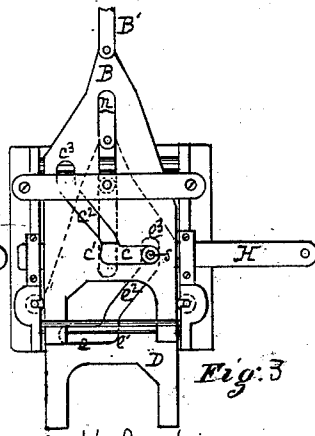

Fig. 5

Witnesses  
 C. L. Parker  
 R. A. Whittlesey

Inventor Caleb H. Jackson  
 By Attorney George A. Christy



# UNITED STATES PATENT OFFICE.

CALEB H. JACKSON, OF HARRISBURG, PENNSYLVANIA.

## RAILROAD SAFETY-SWITCH APPARATUS.

SPECIFICATION forming part of Letters Patent No. 223,516, dated January 13, 1880.

Application filed November 6, 1879

To all whom it may concern :

Be it known that I, CALEB H. JACKSON, of Harrisburg, county of Dauphin, State of Pennsylvania, have invented or discovered a new and useful Improvement in Railroad Safety-Switches; and I do hereby declare the following to be a full, clear, concise, and exact description of the invention, reference being had to the accompanying drawings, making a part of this specification, in which—like letters indicating like parts—

Figure 1, Sheet 1, shows, in perspective, my improved device in one position of adjustment. Fig. 2 is a longitudinal sectional elevation in the plane of the line *xx* of Fig. 1. Figs. 3, 4, and 5 are top or plan views, on a reduced scale, of the same apparatus, showing its different adjustments in ordinary use; and Fig. 6, Sheet 2, is an outline or diagram illustrative of the manner of using the invention.

The present invention relates to certain improvements in apparatus for operating what are commonly known as "interlocking switches and signals," used in or connected with railway-tracks; and the chief object which I have in mind is a construction which will enable me to operate a three-throw switch by the use of two switch-levers, in connection with three signal-levers, (all interlocking,) such as are employed in what is commonly known as the "Saxby and Farmer interlocking switch," and in such manner that while the switch and signal levers are interlocked, as in said apparatus, as against mistakes of the switchman, the movable switch-rails will, by the apparatus itself, be securely locked in each of their three positions as against any and all tendency to be displaced by the irregular movements of a passing train.

The relationship of my present invention to the Saxby and Farmer apparatus is illustrated in Fig. 6, Sheet 2, so far as is necessary to an understanding of what is claimed herein.

A main line or track is represented at X, and the movable switch-rails of a three-throw stub-switch at X'. Y represents one siding, and Z the other.

At B D, I arrange the apparatus, hereinafter described, and connect it by the stems B' D' with switch-levers, (represented by lines B<sup>3</sup> D<sup>3</sup>.) Each line of track has a signal, as at 2, 4, and

6, and these signals are operated by levers, (illustrated by lines at 1, 3, and 5.) All the levers interlock as in the Saxby and Farmer system; but in such system three switch-levers have heretofore been used as well as three signal-levers. By my present improvement I get rid of one switch-lever, and also lock the movable rails as against all tendency to be thrown out of position by the action of the train itself.

In the drawings, A represents any suitable box, foundation, or support, within which the slotted switch plates or frames B D are to be worked by a longitudinally-sliding motion—forward and back. These plates or frames may be guided in any suitable or convenient way, as by grooves or tongues, but preferably by transverse friction-rollers *aa* and vertical edge-bearing rollers *a' a'*. Each plate also has, by preference, a central slot, *n*, extending in the direction of its motion, as long as the motion, and with a guide-roller, *n'*, mounted in a cross-bar of the box working therein.

The plates B D have the usual connections B' D', which are to extend to the switch-levers, which latter may be of any known construction. One plate, B, has a slot, designated generally as B<sup>2</sup>. One end, *e*, of this slot extends from a point, *e'*, which in the adjustment of the apparatus is about midway between the extremes of motion imparted to the switch-bar H in one direction in the direction of the motion of the bar a distance equal or about equal to half its entire stroke. From *e'* the slot extends in a diagonal direction, as at *e*<sup>2</sup>, a distance which represents the hypotenuse of a right-angled triangle, of which the prolongation of *e* in the opposite direction a distance equal to its length would give the base. This part of the slot terminates in a seat, *e*<sup>3</sup>, having parallel sides running at right angles to the direction of the motion of the bar H, or nearly or practically so, made with reference to the function thereof.

The other plate, D, has a slot, lettered generally as D<sup>2</sup>, but which in its position or direction is the reverse of B<sup>2</sup>. Fixing the central or middle joint, *e'*, as before, one end, *e*, extends transversely across the plate the same distance as *e*, but in the opposite direction, and the diagonal part *e*<sup>2</sup> in like manner repre-

sents a hypotenuse to an assumed prolongation of  $e$ , and terminates in a similar seat,  $e^3$ .

A stem or journal,  $s$ , passing through the bar  $H$ , has a friction-roller,  $s'$ , at each end, one of which plays neatly in each slot. The outer end of the bar  $H$  is connected, by the usual bridle or otherwise, with the movable switch-rails, and it is guided in its endwise motion by passing through the proper openings or mortises in the box  $A$ , or otherwise, as may be preferred.

Assuming, now, the devices thus described to be in the position illustrated in Figs. 1 and 3, the bar  $H$  is at the outer end of its stroke. The switch-rails  $X'$  will then be in line with the side track  $Z$ . The signals for lines  $X$  and  $Y$  will then be at "danger," and the shifting of the signal 6 by lever 5 from its previous position of "danger" to "safety" will lock all the other devices in their proper positions. When the devices (Figs. 1 and 3) are in this position the stem  $s$  of the switch-bar  $H$  occupies a position in the seat  $e^3$  such that it cannot be moved without first moving the plate  $D$ ; hence it cannot be moved by any irregularities of motion or other force of the passing train. It is supported securely on both sides in the direction in which the switch-rails must move if they move at all, and being so supported it can only be moved by moving the plate  $D$ ; hence the rails  $X'$  cannot be thrown out of position by any action of the train in passing.

Assume, in the next place, that the train has passed over this line, and that the operator desires to pass a train over line  $X'$ . For this purpose, by properly working his levers, he unlocks the previous combination, shifts signal 6 from "safety" to "danger," puts  $X'$  and  $X$  in line, and shifts signal 4 from "danger" to "safety;" but in shifting  $X'$  into line with  $X$ , the switchman, by operating the lever  $D^3$ , moves the plate  $D$  forward, and thus causes the stem  $s$  to move to the left along the slots  $e^2$  and  $e$  until the devices come into the position shown in Fig. 4, in which it will be seen that the friction-rollers  $s'$  on the upper and lower ends of the stem  $s$  are inclosed as against a motion in the direction of the length of the bar  $H$  by the straight side of the seat  $e'$  coming against one side of the upper roller, and the straight side of the seat  $e'$  coming against the opposite side of the other roller; hence the bar  $H$  and with it the switch-rails  $X'$  are securely locked as against all tendency of the train to force, push, or jar them out of line with the rails  $X$ . The train having passed over this line, if connection of  $X'$  with  $Y$  be desired the switches and signals are unlocked, as before. The operator then shifts his switch-lever  $B^3$ , so as to give to  $B$  a backward thrust, and in so doing causes the stem  $s$  to follow the slot  $e$  and  $e^2$ , resting finally in the seat  $e^3$ , as shown in Fig. 5, where the parallel sides of the seat perform the same function as is already described in connection with the seat  $e^3$ .

From this description reverse movements will be so readily understood that they need not be explained.

In a two-throw switch (illustrated in Fig. 7) the apparatus will itself be interlocking. Thus used a connection is to be made from the switch-levers  $B^3 D^3$  to the usual signals 4 6, so that the switches and signals can be worked by the same levers. Then, with the devices in the position illustrated in Figs. 1 and 3, the line  $X' Z$  will be open, the signal 4 at "danger," and the signal 6 at "safety;" also, the stem  $s$  of the switch-bar  $H$  occupies a position in the transverse slot  $e$  of the plate  $B$ , so that plate  $B$  cannot be moved; hence the danger-signal on line  $X$  cannot be moved to safety, nor can  $H$  be shifted, except by moving the plate  $D$ ; but the first movement of plate  $D$  will shift its signal on line  $Z$  from "safety" to "danger;" but assuming that the train has passed over the line  $Z$ , it is desired to close that line and shift the switch so as to open the line  $X$ .

It will be observed that the lower end of the stem  $s$ , with its roller  $s'$ , is now in the seat  $e^3$  at the end of the diagonal slot  $e^2$ . The switchman, by operating his lever, moves the plate  $D$  forward, and thus simultaneously shifts the signal 6 of line  $Z$  from "safety" to "danger," and also causes the stem  $s$  to move to the left along the slot  $e^2$  and  $e$  until the devices come into the position shown in Fig. 4.

The movable switch-rails are then midway between their proper positions for connecting with or opening the two lines, and both signals are at "danger." Then he takes his other switch-lever, which is connected with  $B$ , gives it a backward thrust, and in so doing causes the stem  $s$  to follow the slot  $e$  and  $e^2$ , resting finally in the seat  $e^3$ , as shown in Fig. 5. The same motion of the switch-lever which does this also shifts the signal 4 of  $B$  (on line  $X$ ) from "danger" to "safety." Line  $X$  is then open, and its signal is in the proper position. The plate  $D$  is now locked by the roller  $s'$  of stem  $s$  engaging the sides of the transverse slot  $e$ , so that the danger-signal on line  $Z$  is locked, and the switch cannot be shifted except by giving  $D$  a forward thrust; but this would instantly change the signal for that line from "safety" to "danger," so as to avert possibility of accident from improper signals.

Thus it will be seen that when either switch-connection is broken or closed the proper signal is locked at "danger;" when either switch-connection is open or unbroken the proper signal is and must be at "safety;" that the first motion in breaking a connection involves the shifting of the safety-signal to "danger," and that a danger-signal comes to a "safety" position only on the closing of a switch-connection.

I claim herein as my invention—

1. A pair of switch-shifting plates, each longitudinally movable by a connection to the switch-levers, and each having a transverse

and a diagonal slot, and forming seats as a means of imparting motion to and locking a switch-bar, substantially as set forth.

2. The plates B D, having each the arrangement of slots shown and described, each diagonal slot ending in a seat,  $c^3 e^3$ , and conjointly forming a middle seat,  $c' e'$ , substantially as and for the purpose set forth.

3. The plates B D, having slots and seats,

as described, in combination with bar H, having stem  $s$  and friction-rollers  $s'$ , substantially as set forth.

In testimony whereof I have hereunto set my hand.

CALEB H. JACKSON.

Witnesses:

R. H. WHITTLESEY,  
GEORGE H. CHRISTY.