

(12) PATENT
(19) AUSTRALIAN PATENT OFFICE

(11) Application No. AU 199860527 B2
(10) Patent No. 742712

(54) Title
Vascular filter

(51)⁷ International Patent Classification(s)
A61B 017/22

(21) Application No: **199860527**

(22) Application Date: **1998.02.03**

(87) WIPO No: **WO98/33443**

(30) Priority Data

(31) Number	(32) Date	(33) Country
08/794011	1997.02.03	US

(43) Publication Date : **1998.08.25**

(43) Publication Journal Date : **1998.10.22**

(44) Accepted Journal Date : **2002.01.10**

(71) Applicant(s)
AngioGuard, Inc.

(72) Inventor(s)
Jay S. Yadav

(74) Agent/Attorney
DAVIES COLLISON CAVE,GPO Box 3876,SYDNEY NSW 2001

(56) Related Art
US 4723549
US 5053008



60527/98

pages 1/14-14/14, drawings, replaced by new pages 1/14-14/14; due to

INTERNATIONAL late transmittal by the receiving Office

OPERATION TREATY (PCT)

<p>(51) International Patent Classification ⁶ : A61B 17/22</p>	<p>A1</p>	<p>(11) International Publication Number: WO 98/33443 (43) International Publication Date: 6 August 1998 (06.08.98)</p>
<p>(21) International Application Number: PCT/US98/01894 (22) International Filing Date: 3 February 1998 (03.02.98) (30) Priority Data: 08/794,011 3 February 1997 (03.02.97) US (71) Applicant (for all designated States except US): ANGIO-GUARD, INC. [US/US]; 735 Aran Drive, Roswell, GA 30076 (US); 2950 Zenium Lane Plymouth MN 55441 (72) Inventor; and United States of America (75) Inventor/Applicant (for US only): YADAV, Jay, S. [US/US]; 735 Aran Drive, Roswell, GA 30076 (US). (74) Agents: DIPPERT, William, H. et al.; Cowan, Liebowitz & Lataman, P.C., 1133 Avenue of the Americas, New York, NY 10036-6799 (US).</p>		<p>(81) Designated States: AL, AM, AT, AU, AZ, BA, BB, BG, BR, BY, CA, CH, CN, CU, CZ, DE, DK, EE, ES, FI, GB, GE, GH, GM, GW, HU, ID, IL, IS, JP, KE, KG, KP, KR, KZ, LC, LK, LR, LS, LT, LU, LV, MD, MG, MK, MN, MW, MX, NO, NZ, PL, PT, RO, RU, SD, SE, SG, SI, SK, SL, TJ, TM, TR, TT, UA, UG, US, UZ, VN, YU, ZW, ARIPO patent (GH, GM, KE, LS, MW, SD, SZ, UG, ZW), Eurasian patent (AM, AZ, BY, KG, KZ, MD, RU, TJ, TM), European patent (AT, BE, CH, DE, DK, ES, FI, FR, GB, GR, IE, IT, LU, MC, NL, PT, SE), OAPI patent (BF, BJ, CF, CG, CI, CM, GA, GN, ML, MR, NE, SN, TD, TG).</p> <p>Published <i>With international search report.</i></p> <div data-bbox="1021 851 1500 1120"><p>IP AUSTRALIA 11 JAN 1999</p></div>

see
folio
4

(54) Title: **VASCULAR FILTER**

(57) Abstract

A removable vascular filter for blocking micro-emboli, and macro-emboli while allowing the continued perfusion of blood comprising a filter membrane (20), wherein the free end of the membrane sits tightly against the guide wire (10) when the filter membrane is in a collapsed state, and wherein the filter has a means for deploying the filter membrane in the interior of a lumen which is comprised of cables or spines (30) operable with a movable core (40), or fibers inside the guide wire which transitions the filter membrane from the collapsed state to the deployed state. The filter membrane is comprised of a fine mesh material which has a pore size capable of blocking emboli while allowing continued blood flow.

(54) Title: **VASCULAR FILTER**

*(Referred to in PCT Gazette No. 52/1998, Section II)

VASCULAR FILTER

FIELD OF THE INVENTION

The present invention relates to the treatment of vascular disease of either surgery or percutaneous angioplasty and stenting. More particularly, the invention relates to a device
5 that reduces macro- and micro-embolism during the treatment of vascular stenosis.

BACKGROUND OF THE INVENTION

A variety of surgical and non-surgical angioplasty
10 procedures have been developed for removing obstructions from blood vessels. Balloon angioplasty utilizes a balloon-tipped catheter which may be inserted within a stenosed region of the blood vessel. By inflation of the balloon, the stenosed region is dilated. Surgery involves either removing the plaque from
15 the artery or attaching a graft to the artery so as to bypass the obstructing plaque. Other techniques, such as atherectomy, have also been proposed. In atherectomy, a rotating blade is used to shave plaque from an arterial wall.

One problem common with all of these techniques is the
20 accidental release of portions of the plaque or thrombus, resulting in emboli which can lodge elsewhere in the vascular system. Such emboli are, of course, extremely dangerous to the patient, frequently causing severe impairment of the distal circulatory bed. Depending upon the vessel being treated, this
25 may result in a stroke or myocardial infarction or limb ischemia.

Vascular filters or embolism traps for implantation into the vena cava of a patient are well known, being illustrated by, for example, U.S. Patents. Nos. 4,727,873 and 4,688,553.
30 Additionally, there is a substantial amount of medical literature describing various designs of vascular filters and reporting the results of the clinical and experimented use thereof. See, for example, the article by Eichelter & Schenk entitled "Prophylaxis of Pulmonary Embolism," Archives of

Surgery, Vol. 97, August 1968, pp. 348 et seq. See, also, the article by Greenfield, et al., entitled "A New Intracaval Filter Permitting Continued Flow and Resolution of Emboli", Surgery, Vol. 73, No. 4, pp. 599-606 (1973).

5 Vascular filters are used, often during a postoperative period, when there is a perceived risk of a patient encountering a pulmonary embolus resulting from clots generated at the surgical site or the like. As a typical use of vascular filters, the filter is mounted in the vena cava to catch large
10 emboli passing from the surgical site to the lungs.

The vascular filters of the prior art are usually permanently implanted in the venous system of the patient, so that even after the need for the filter has abated, the filter remains in place for the lifetime of the patient, absent
15 surgical removal. U.S. Pat. No. 3,952,747 describes a stainless steel filtering device which is permanently implanted transvenously within the inferior vena cava. The filtering device is intended to treat recurrent pulmonary embolism. U.S. Pat. No. 4,873,978 describes a catheter device comprising a
20 catheter body having a strainer mounted at its distal end. The strainer is shiftable between an opened configuration where it extends substantially across the blood vessel to entrap passing emboli, and a closed configuration where it retains the captured emboli during removal of the catheter. A mechanism
25 actuatable at the proximate end of the catheter body allows selective opening and closing of the strainer. Typically, the strainer is a collapsible cone having an apex attached to a wire running from the distal end to the proximate end of the catheter body.

30 Permanent implantation is often deemed medically undesirable, but it has been done because vascular filters are implanted in patients primarily in response to potentially life threatening situations. Accordingly, the disadvantages of permanent implantations of a vascular filter are often
35 accepted.

To avoid permanent implantation, it would be highly desirable to provide an apparatus and method for preventing

embolisms associated with conventional surgery and angioplasty procedures. In particular, it would be desirable to provide a device which could be located within the vascular system to collect and retrieve portions of plaque and thrombus which have
5 dislodged during the surgery or angioplasty procedure.

SUMMARY OF THE INVENTION

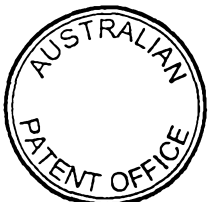
The present invention generally relates to the surgical and interventional treatment of vascular disease. For example,
10 during angioplasty and stenting of carotid stenosis, there is occurrence of macro- and micro-embolism which increases the risk of a minor or major stroke. The device of the present invention for reducing macro- and micro-embolism is very useful in helping to prevent the risk of stroke. However, this device would also be useful in any angioplasty or surgical procedure
15 where embolization is a risk.

The filters of the present invention will decrease embolism while allowing brain, or other distal tissue, perfusion. The filters are incorporated into a guidewire which
20

25

30

35



is used for the entire procedure from crossing a lesion to
deploying a stent. The filter consists of a thin membrane
attached to the guidewire and supported by fine metal spines.
The filter membrane has a pore size such that blood flow is not
5 impeded when the filter membrane is expanded but micro- and
macro-emboli are blocked. The attachments of the filter
membrane to the guidewire allow expansion of the filter
membrane with a firm fit inside the artery. Expansion of the
filter membrane is aided by the forward flow of blood against
10 the filter. The attachments also allow for collapse of the
filter membrane at the end of the procedure so it fits tightly
against the guidewire and can be withdrawn through the guide
catheter. The filter design results in a very low profile so
that the initial crossing of the lesion is minimally traumatic.
15 Also, the small diameter and small profile facilitate use of
the device in small or larger arteries with minimal or no
obstruction of blood flow.

In accordance with the present invention there is
provided a removable percutaneous vascular filter device for
20 blocking micro-and macro-emboli while allowing continued
perfusion of blood, comprising: a guidewire having distal
and proximal portions, wherein there is a recess in the
distal portion, the recess having distal and proximal ends,
a filter comprising (a) a non-metallic, porous, flexible
25 filter membrane having a distal portion and a proximal free
portion and (b) a filter membrane support structure
extending from the flexible filter membrane distal portion
to at least the flexible filter membrane proximal portion,
30 wherein said filter membrane distal portion is pivotably
attached to the guidewire near said distal end of the
guidewire recess and wherein the filter membrane free end
portion is positioned in the recess substantially parallel
to the guidewire when the filter membrane is in a collapsed
state; and deploying means operatively connected to the
35 filter to cause the filter membrane proximal free end
portion to move from a position substantially parallel to



-4a-

the guidewire when the filter membrane is in a collapsed state; and deploying means operatively connected to the filter to cause the filter membrane proximal free end portion to move from a position substantially parallel to the
5 guidewire to a position removed from the longitudinal axis of the guidewire to cause the flexible membrane to form a substantially conical shape to form a generally sealing relationship with the wall of said vessel.

10 In accordance with a further aspect of the present invention there is provided a removable vascular filter device for blocking micro-and macro-emboli while allowing continued perfusion of blood, comprising: a guidewire having distal and proximal portions, wherein there is a recess in
15 the distal portion, the recess having distal and proximal ends, a filter membrane having a fixed inner portion and a free outer portion, wherein the fixed inner portion is attached toward the distal end of the guidewire recess and wherein the free outer portion is positioned in the recess
20 when the filter membrane is in a collapsed state, and wherein the filter membrane in an unstressed position assumes a position substantially normal to the longitudinal axis of the guidewire, and means for collapsing the filter membrane from a deployed state to a collapsed state.

25

In accordance with another aspect of the present invention there is provided a removable vascular filter device for blocking micro-and macro-emboli while allowing continued perfusion of blood, comprising: a catheter having
30 distal and proximal portions, wherein there is a recess in the distal portion, the recess having distal and proximal ends, and the catheter has a longitudinally extending lumen; a filter membrane having a fixed inner portion and a free outer portion, wherein the fixed inner portion is movably



-4b-

attached toward the distal end of the catheter recess,
 wherein the free outer portion is positioned in the recess
 when the filter membrane is in a collapsed state, and
 wherein the filter membrane is unstressed and extends
 5 substantially normal to the outer surface of the catheter;
 and a collapsing means for causing the filter membrane to
 collapse into the catheter recess, wherein the outer surface
 of the catheter has a guidewire port for receipt of a
 guidewire.

10

BRIEF DESCRIPTION OF THE DRAWINGS

The above and other objects and advantages of the
 invention will be apparent upon consideration of the following
 detailed description, taken in conjunction with the
 15 accompanying drawings, in which the reference characters refer
 to like parts throughout and in which:

Fig. 1 is a lateral, partly cross-sectional view of the
 distal end of a guidewire of one embodiment of the invention
 with the filter membrane in a collapsed position;

20

Fig. 2 is a lateral, partly cross-sectional view of the
 distal end of a guidewire of Fig. 1 with the filter membrane in
 an expanded, deployed position;

Fig. 3 is a proximal end-on view of the filter membrane
 shown in Fig. 2;

25

Fig. 4 is a lateral, partly cross-sectional view of
 another embodiment of the invention;

Fig. 5A is a lateral, partly cross-sectional view of a
 further embodiment of the invention;

30



Fig. 5B is a lateral, partly cross-sectional view of the embodiment of the invention shown in Fig. 5A with the filter membrane in an expanded, deployed position;

Fig. 6 is a partly cross-sectional view of a control
5 handle for the invention;

Fig. 7 is a partly cross-sectional view of another embodiment of the invention;

Fig. 8 is a partial cross-sectional view of an embodiment of the invention wherein the filter membrane has curved
10 supports;

Fig. 9 is a partial cross-sectional view of yet another embodiment of the invention wherein the filter membrane has a spiral wire;

Fig. 10 is a top, cross-sectional view of the embodiment
15 of the invention shown in Fig. 9;

Fig. 11 is a partial cross-sectional view of another embodiment of the invention having inflatable support spines;
and

Figs. 12 and 13 represent partial cross-sectional views of
20 another embodiment of the invention in collapsed and deployed positions, respectively.

DETAILED DESCRIPTION OF THE INVENTION

The present invention relates to a vascular filter for use
25 in percutaneous angioplasty and stenting and provides for the prevention of distal embolism during endovascular procedures. Further, the filter device of the invention allows for distal perfusion while preventing embolism.

The device consists of a thin, perforated filter membrane
30 which is capable of blocking emboli and which is attached to the distal end of a guidewire. The device preferably uses thin fibers which are moveable and are attached to the filter membrane to deploy and collapse the filter membrane. The invention also contemplates the use of metal spines or
35 inflatable spines attached to the filter membrane to deploy the

filter membrane. The fibers or spines can also be attached to a moveable core which is slidable within the guidewire and is used to deploy and collapse the filter membrane.

The filter membrane deploys in an umbrella-like fashion with the unattached edge of the membrane moving upward, i.e., distally, and outward until it is in firm contact with an artery wall. When the filter membrane is deployed, it spans the cross-sectional area of the vessel lumen being treated for a stenosis such as carotid stenosis, or another condition likely to produce emboli.

The invention can perhaps be appreciated better by referring to the drawings. Fig. 1 illustrates a lateral, cross-sectional view of a distal end of a guidewire 10 with a filter membrane 20 attached thereto. Fig. 1 shows guidewire 10 with a shapeable, tapered soft tip 15 at its extreme distal end which provides flexibility and maneuverability to guidewire 10. The filter membrane in Fig. 1 is in a collapsed position. Filter membrane 20 has a fixed portion 24 which is movably attached to guidewire 10, and filter membrane 20 lies adjacent guidewire 10 proximal to fixed portion 24 when filter membrane 20 is in the collapsed state. A moveable core 40 runs through a center lumen 11 of guidewire 10 and preferably extends distally a short distance beyond fixed portion 24 of filter membrane 20. Deploying wires or fibers 30 are each firmly attached at one end 27 to moveable core 40 distal to fixed portion 21 of filter membrane 20. The deploying fibers 30 are attached at their other ends to filter membrane 20 at attachment points 22.

Collapsing fibers 35 are each firmly attached at one end 12 to the portion of moveable core wire 40 which is interior to filter membrane 20 when it is in the collapsed state. Collapsing fibers 35 are each attached at their other end 13 to filter membrane 20 at attachment points 22. Accordingly, collapsing fibers 35 lie interior to filter membrane 20 when filter membrane 20 is in the collapsed state.

Filter membrane 20 is deployed when the operator pulls moveable core 40 proximally through the interior of guidewire

10. Prior to retraction of moveable core 40, deploying fibers 30 are sufficiently relaxed so as not to create any tension at filter membrane attachment points 22. Upon retraction of moveable core 40, tension is created in deploying fibers 30.

5 There will preferably be from 2 to 6 each of evenly-spaced
deploying fibers 30 and collapsing fibers 35, 3 or 4 being most
preferred. The deploying fibers 30 and collapsing fibers 35
can be made of any flexible, medically acceptable material,
including stainless steel, nitinol, or another metal or
10 metallic alloy or a non-metallic substance such as graphite or
a suitable polymer. In addition, guidewire 10 and moveable
core 40 can be made from similar materials, as would be
appreciated by those skilled in the art. Typically, guidewire
10 could have an external diameter of from about 0.014 mm to
15 about 0.035 mm, a wall thickness of from about 0.002 mm to
about 0.010 mm, and a length of from about 25 cm to about 300
cm. Also, moveable core 40 could have a diameter of from about
0.003 mm to about 0.010 mm and a length of from about 30 cm to
about 350 cm.

20 Fig. 2 illustrates the filter device of the invention in a
deployed position on the inside of an artery wall 60. Moveable
core 40 is in a retracted state, i.e., pulled proximally
through the interior of guidewire 10. Tension is created in
deploying fibers 30, and filter membrane 20 extends to a
25 deployed position where the outer edge 14 of filter membrane 20
contacts artery wall 60. In this deployed position, collapsing
fibers 35 are in a relaxed state and extend from filter mem-
brane attachment points 22 to fixed attachment points 28 on
moveable core 40.

30 The flow of blood in Fig. 2 is toward the distal end of
guidewire 10. As such, the force of the flow of blood pushes
on deployed filter membrane 20 and helps to maintain filter
membrane 20 in the deployed position.

 For withdrawal of guidewire 10 and the filter device,
35 filter membrane 20 is collapsed so that it sits tightly against
guidewire 10. This is accomplished by extending moveable core
40 distally through guidewire 10, thus relaxing deploying

fibers 30 and creating tension in collapsing fibers 35. The tension in collapsing fibers 35 collapses the filter membrane 20, allowing it to fit tightly against guidewire 10 in recess 16 as depicted in FIG. 1.

5 Fig. 3 illustrates the filter device of the invention from a distal end view in Fig. 2 with filter membrane 20 deployed. Guidewire 10 is centrally located, and structural wires 50 are seen extending from guidewire 10 to the outer edge 14 of filter
10 membrane 20. These wires 50 provide structural integrity and rigidity to filter membrane 20. Fig. 3 depicts four, evenly-spaced structural wires 50, but there can be more or less structural wires 50. Preferably there are from two to six structural wires 50, which may be spaced regularly or irregularly. The wires 50 may preferably be comprised of
15 stainless steel or another medically acceptable metal or alloy.

Filter membrane 20 of the invention is preferably a mesh such as that depicted in Fig. 3. The mesh should have pores of a size sufficient to block and capture any micro- and macro-emboli which may flow downstream from the site where the
20 stenosis is being treated, but large enough such that blood flow is not impeded. The mesh used in the filter device of the invention can have a pore size of from about 20 to about 300 microns, preferably from about 30 to about 100 microns, more preferably from about 40 to 60 microns. Moreover, the size of
25 filter membrane 20, i.e., the distance from guidewire 10 to free ends 22, is such as to allow a firm fit between filter membrane 20 and artery wall 60. The diameter of filter membrane 20 will be directly related to the artery being treated, with typical diameters ranging from about 2 mm to
30 about 40 mm, most preferably from about 2 mm to about 20 mm.

The membrane can be comprised of fabric or non-fabric meshes, such as those used in known hemodialysis filters or heart-lung bypass machine filters. Suitable materials include polymers or physiologically acceptable metals or alloys.

35 In alternative embodiments of the invention shown in Figs. 4, 5A and 5B, filter membrane 20 will be suspended between from two to six, preferably three or four, thin metal wires 51 which

serve as spines for filter membrane 20. Wires 51 may be comprised of stainless steel or another metallic alloy, nitinol, or another shape-memory material. Wires 51 will be constructed so that they assume a 90° angle with guidewire 10 when they are in an unconstrained state. This will result in expansion of the filter membrane 20 to a position normal to guidewire 10. A set of thin fibers 17 are attached at attachment points 18 to filter membrane outer edge 14 and are used to collapse filter membrane 20.

10 Fig. 4 shows an embodiment of this invention in which metal wires 51 are allowed to regain their 90° angle unconstrained state by use of a moveable core 40 that runs through guidewire 10. Prior to retraction of moveable core 40, fibers 17 are sufficiently tensed so as to restrain wires 51. 15 Upon retraction of moveable core 40, tension in fibers 17 is released and wires 51 are allowed to revert to their relaxed shape, which will result in expansion of filter membrane 20 to a position normal to guidewire 10.

Figs. 5A and 5B show an embodiment of the invention 20 wherein wires 51 are restrained by fibers 17 that run through guidewire 10 and that are controlled at a remote location. In Fig. 5A, there is sufficient tension in fibers 17 to maintain wires 51 in a constrained position. In Fig. 5B, tension in fibers 17 has been relaxed such that wires 51 are allowed to 25 revert to their relaxed shape, which will result in expansion of filter membrane 20 to a position normal to guidewire 10.

Fig. 6 depicts a control handle especially suitable for the embodiment of the invention shown in Figs. 5A and 5B. The proximal end 32 of guidewire 10 is rotatably attached to handle 30 33, such that rotation of handle 33 causes handle 33 to move distally or proximally relative to proximal guidewire end 32. For example, handle 33 may have threads 34 which engage threads 35 on guidewire proximal end 32. Fibers 17 attached to filter membrane 20 are secured in a base 36 of handle 33. Then, as 35 handle 33 is turned, the fibers 17 move distally or proximally to open or close filter membrane 20.

As handle 33 is turned clockwise in the direction of arrow A and fibers 17 are allowed to move distally in the direction of arrow C, the tension on the filter membrane fibers 17 decreases and wires 51 are allowed to assume their natural 90° angle with respect to the guidewire, resulting in opening of filter membrane 20. Similarly, when handle 33 is turned counter-clockwise in the direction of arrow B and fibers 17 are pulled proximally in the direction of arrow D, the tension on filter fibers 17 increases, causing filter membrane 20 to collapse tightly against guidewire 10. Of course, the direction of turn of handle 33 as discussed above can be reversed, as long as threads 34,35 are properly formed to allow appropriate movement of handle 33 relative to guidewire proximal end 32.

In yet another embodiment of the invention, shown in Fig. 11, filter membrane 20 can be supported by inflatable spines 135 supporting the filter membrane 20. Spines 135 supporting the filter membrane 20 are from two to six hollow plastic tubes which are inflatable using, for example, a standard balloon angioplasty inflation device or endoflator in fluid connection through channel 137 with spines 135. Inflation of spines 135 causes them to become rigid and deploys filter membrane 20. The underside of the filter membrane is attached to very thin fibers 17 which are attached to moveable core 40 inside hollow guidewire 10. Filter membrane 20 is collapsed by deflating the spines 135 and withdrawing the moveable core 40 in the direction of arrow E until the membrane 20 fits tightly against guidewire 10.

A catheter-based configuration is also possible, as shown in FIG. 7. In this design, the guidewire is not part of the filter catheter; the guidewire and filter catheter are two separate components. The filter catheter has an entry hole for the guidewire below the attachment of the filter membrane and the guidewire exits out the end of the filter catheter. The filter catheter could be designed to accommodate a variety of guidewire sizes, most commonly a 0.014 inch guidewire. The advantages of this design are that a variety of guidewires

could be used; the lesion could be crossed with the guidewire prior to crossing with the filter catheter; the filter catheter could be removed from the artery without removing the guidewire; and the filter catheter could be made smaller.

5 In the embodiment of the invention shown in Fig. 7 a catheter 101 comprises a longitudinally extending lumen 103, which has an annular recess 105 adjacent the distal end of catheter 101. Positioned within recess 105 is a filter 107 comprised of structural wires 109 and a filter membrane 111.
10 The distal end of each of wires 109 is attached at point 113 in recess 105. Fibers 117 extend from the proximal ends 119 of wires 109 proximally to a control means such as described in Fig. 6.

Catheter 101 contains guidewire port 125 located proximal
15 to recess 105. It is intended that in use the distal portion 128 of a guidewire 127 will be threaded into the distal end 129 of catheter 101 and out through port 125.

Alternatively, and not shown here, a catheter 101 could
20 comprise a longitudinally extending lumen and a shorter tracking lumen that extends from distal end 129 to a point proximal to recess 105. The distal end of guidewire 127 would then be threaded into the distal opening of the tracking lumen and out the proximal end of the tracking lumen.

Spiral or curved structural wires may be used to deploy
25 the filter membrane instead of straight wires. Fig. 8 illustrates the use of four curved wires 120. The angulation of the filter attachment point of wires 120 relative to their guidewire attachment has the effect of wrapping the filter fabric around the guidewire in the undeployed state. This
30 leads to a lower profile for the undeployed filter.

Figs. 9 and 10 illustrate the use of a single spiral
structural wire 130 which is attached to the filter 107. As
tension fiber 131 is released, wire 130 unwinds and deploys
filter 107 in a conical configuration. This configuration has
35 the simplicity of using a single wire and, when the tension on fiber 131 is increased, allows filter 107 to be wrapped very

tightly around the guidewire shaft 131, resulting in filter 107 having a low profile in its undeployed state.

Another modification shown in Figs. 12 and 13 comprises a retractable sheath 140 at the distal end of guidewire 142 which covers filter membrane 144 in the collapsed state. Sheath 140, the distal portion of which is affixed to guidewire tip 146, which is affixed to the distal end of moveable core 148, would prevent an edge 150 of filter membrane 144 from becoming entangled in an artery or guide catheter as it was being withdrawn from a patient.

More specifically, when guidewire 142 with tapered tip 146 is inserted percutaneously into a patient, sheath 140 covers collapsed filter membrane 144. After the filter membrane is determined by fluoroscopy to be in proper position, moveable core 148 is pushed distally to cause sheath 140 to "release" filter membrane 144, which has spines 152, to cause filter membrane 144 to deploy, as shown in Fig. 13.

It will be seen that the objects set forth above, among those made apparent from the preceding description, are efficiently attained and, since certain changes may be made in carrying out the method and in the apparatus set forth without departing from the spirit and scope of the invention, it is intended that all matter contained in the above description and shown in the accompanying drawings shall be interpreted as illustrative and not in a limiting sense.

It is also to be understood that the following claims are intended to cover all of the generic and specific features herein and described and all statements of the scope of the invention which, as a matter of language, might be said to fall therebetween.

ITEM LISTING

	<u>No.</u>	<u>Item</u>
5	10	Guidewire
	11	Guidewire lumen
	12	End of collapsing fiber
	13	End of collapsing fiber
	14	Filter membrane outer edge
10	15	Guidewire soft tip
	17	Collapsing fiber
	18	Attachment point
	20	Filter membrane
	22	Filter membrane attachment point
15	24	Filter membrane fixed portion
	27	Fiber attachment point
	28	Fiber attachment point
	30	Deploying fibers
	32	Guidewire proximal end
20	33	Handle
	34	Handle threads
	35	Guidewire proximal end threads
	36	Handle base
	40	Moveable core wire
25	50	Structural wires
	51	Deploying wires
	60	Artery wall
	101	Catheter
	103	Lumen
30	105	Recess
	107	Filter mesh structure
	109	Filter wire
	111	Mesh
	113	Attachment point
35	117	Deployment collapse wire
	120	Curved filter structural wires
	125	Guidewire port
	127	Guidewire

	128	Guidewire distal end
	129	Spiral wire
	131	Fiber
5	132	Guidewire shaft
	135	Inflatable spines
	137	Inflation channel
	140	Sheath
	142	Guidewire
10	144	Filter member
	146	Tapered guidewire tip
	148	Moveable core
	150	Filter membrane edge
	152	Filter membrane spine

Throughout this specification and the claims which follow, unless the context requires otherwise, the word "comprise", or variations such as "comprises" or "comprising", will be understood to imply the inclusion of a stated integer or group of integers or steps but not the exclusion of any other integer or group of integers or steps.

The reference to any prior art in this specification is not, and should not be taken as, an acknowledgement or any form of suggestion that the prior art forms part of the common general knowledge in Australia.



-15-

The claims defining the invention are as follows:

1. A removable percutaneous vascular filter device for blocking micro-and macro-emboli while allowing continued perfusion of blood, comprising: a guidewire having distal and proximal portions, wherein there is a recess in the distal portion, the recess having distal and proximal ends, a filter comprising (a) a non-metallic, porous, flexible filter membrane having a distal portion and a proximal free portion and (b) a filter membrane support structure extending from the flexible filter membrane distal portion to at least the flexible filter membrane proximal portion, wherein said filter membrane distal portion is pivotably attached to the guidewire near said distal end of the guidewire recess and wherein the filter membrane free end portion is positioned in the recess substantially parallel to the guidewire when the filter membrane is in a collapsed state; and deploying means operatively connected to the filter to cause the filter membrane proximal free end portion to move from a position substantially parallel to the guidewire to a position removed from the longitudinal axis of the guidewire to cause the flexible membrane to form a substantially conical shape to form a generally sealing relationship with the wall of said vessel.
2. The vascular filter of Claim 1, wherein the pore size of the filter membrane is from about 40 to about 300 microns.
3. The vascular filter of Claim 1, wherein the guidewire is hollow and wherein the deploying means comprises a moveable core, the moveable core being slidably positioned in the interior of the guidewire.
4. The vascular filter of Claim 3, wherein the deploying means further comprises deploying fibers each having first and second ends and said filter membrane further comprises an outer edge, and wherein said deploying fibers are each attached at a first end to the moveable core and are attached at a second end to the outer edge of the filter membrane.



5 5. The vascular filter of Claim 3, wherein the moveable core creates a tension in the deploying fibers when it slides proximally in relation to the guidewire, and said tension causes the filter membrane to expand outwardly until the outer edge of the filter membrane is in firm contact with the lumen wall.

10

15

20

25



6. The vascular filter of Claim 4 further comprising a means for collapsing the filter membrane from a deployed state to a collapsed state.

7. The vascular filter of Claim 6, wherein the collapsing means further comprises collapsing fibers each having first and second ends, wherein said collapsing fibers are each attached at a first end to the moveable core and are further attached at a second end to the outer edge of the filter membrane.

8. The vascular filter of Claim 7, wherein the moveable core creates a tension in the collapsing fibers when it slides distally in relation to the guidewire, and said tension causes the filter membrane to collapse tightly against the guidewire.

9. The vascular filter of Claim 1, wherein the guidewire has a lumen extending distally from the proximal portion of the guidewire to at least the recess.

10. The vascular filter of Claim 1, wherein the guidewire has a tapered distal tip.

11. A removable vascular filter device for blocking micro-and macro-emboli while allowing continued perfusion of blood, comprising:

a guidewire having distal and proximal portions, wherein there is a recess in the distal portion, the recess having distal and proximal ends,

a filter comprising a non-metallic, porous, flexible filter membrane and a filter membrane support structure, the filter membrane having a fixed inner portion and a free outer portion, wherein the fixed inner portion is attached toward the distal end of the guidewire recess and wherein the filter membrane free outer portion is positioned in the recess when the filter membrane is in a collapsed state, and wherein the filter membrane in an unstressed position assumes a position substantially normal to the longitudinal axis of the guidewire, and

means operatively connected to the filter to collapse the filter membrane from a deployed state to a collapsed state.



12. The vascular filter of Claim 11, wherein the filter membrane comprises wires which assume a 90° angle with respect to the longitudinal axis of the guidewire in an unconstrained state.

13. The vascular filter of Claim 11, wherein the filter membrane comprises from 2 to 6 arcing wires.

14. The vascular filter of Claim 12, wherein the filter membrane comprises a single spiral wire.

15. The vascular filter of Claim 11, wherein the collapsing means comprises collapsing fibers each having first and second ends, wherein said collapsing fibers are each attached at a first end to the outer edge of the filter membrane and the second end of each fiber extends proximally through the guidewire to an actuator.

16. The vascular filter of Claim 15, wherein the actuator is a handle or shaft that can be rotated clockwise or counter-clockwise to release or collapse the filter membrane.

17. The vascular filter of Claim 11, wherein the filter membrane comprises a set of inflatable spines, said spines being hollow plastic tubes.

18. The vascular filter of Claim 17 which further comprises an inflator for inflating the spines, wherein said inflator is in fluid communication with said spines, which become rigid upon inflation.

19. The vascular filter of Claim 18, where the means of inflation is an endoflator.

20. The vascular filter of Claim 11, wherein the guidewire has a lumen extending distally from the proximal portion of the guidewire to at least the recess.

21. The vascular filter of Claim 11, wherein the guidewire has a tapered distal tip.

22. The vascular filter of Claim 11, which also comprises a sheath positioned concentric to the collapsed filter membrane, wherein said membrane causes the filter



-18-

member to be in a collapsed state but can be moved distally to allow the filter member to extend radially.

23. The vascular filter of Claim 22, wherein the sheath has proximal and distal portions and is attached at its distal end to a distal guidewire tip that is affixed to a moveable core extending proximally through the guidewire.

24. A removable vascular filter device for blocking micro-and macro-emboli while allowing continued perfusion of blood, comprising:

a catheter having distal and proximal portions, wherein there is a recess in the distal portion, the recess having distal and proximal ends, and the catheter has a longitudinally extending lumen;

a filter comprising a non-metallic, porous, flexible filter membrane and a filter membrane support structure, the filter membrane having a fixed inner portion and a free outer portion, wherein the filter membrane fixed inner portion is movably attached toward the distal end of the catheter recess, wherein the filter membrane free outer portion is positioned in the recess when the filter membrane is in a collapsed state, and wherein the filter membrane is unstressed and extends substantially normal to the outer surface of the catheter; and

means operatively connected to the filter to cause a collapsing means, wherein the outer surface of the catheter has a guidewire port for receipt of a guidewire.

25. The vascular filter of Claim 24, wherein the pore size of the filter membrane is from about 40 to about 300 microns.

26. The vascular filter of Claim 24, wherein the collapsing means comprises fibers each having first and second ends and said filter membrane further comprises an outer edge, and wherein said collapsing fibers are each attached at a first end to a control mechanism and are attached at a second end to the outer edge of the filter membrane.



27. Removable vascular filter devices, substantially as hereinbefore described with reference to the accompanying drawings.

5 DATED this 31st day of October, 2001

ANGIOGUARD, INC.

By its Patent Attorneys

DAVIES COLLISON CAVE

10

15

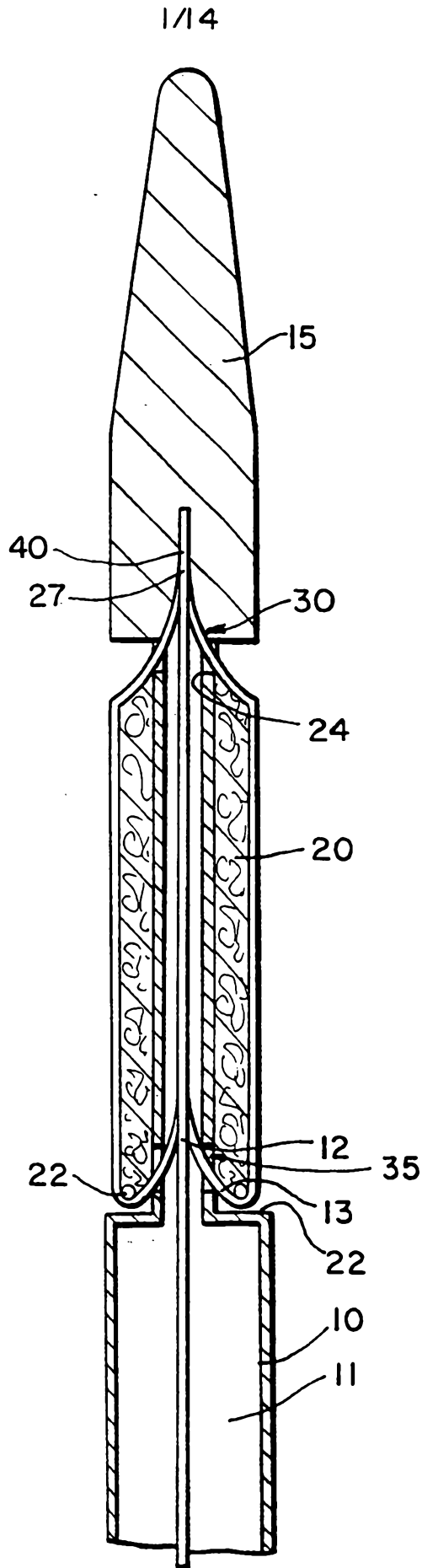
20

25

30

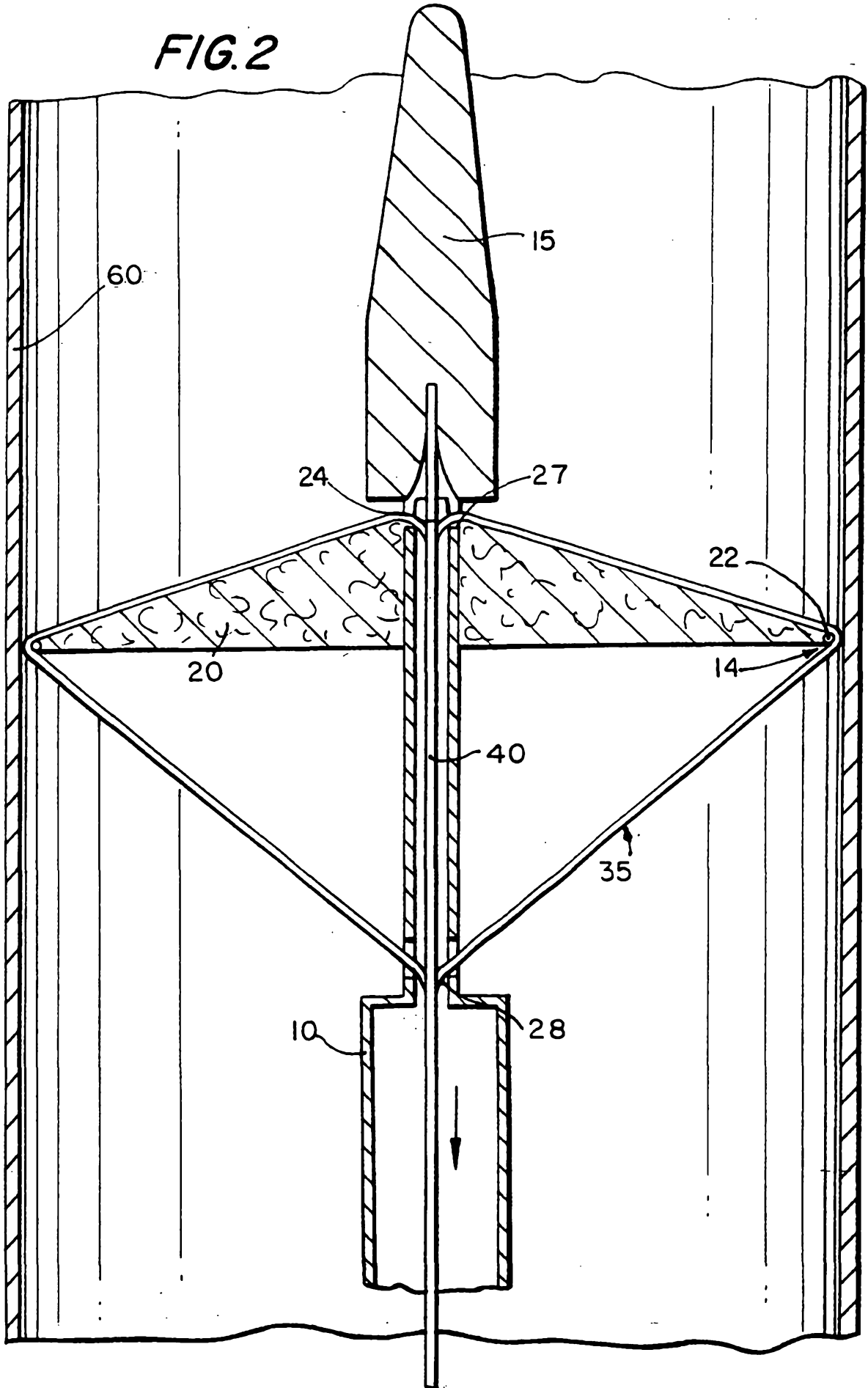


FIG. 1



2/14

FIG. 2



3/14

FIG.3

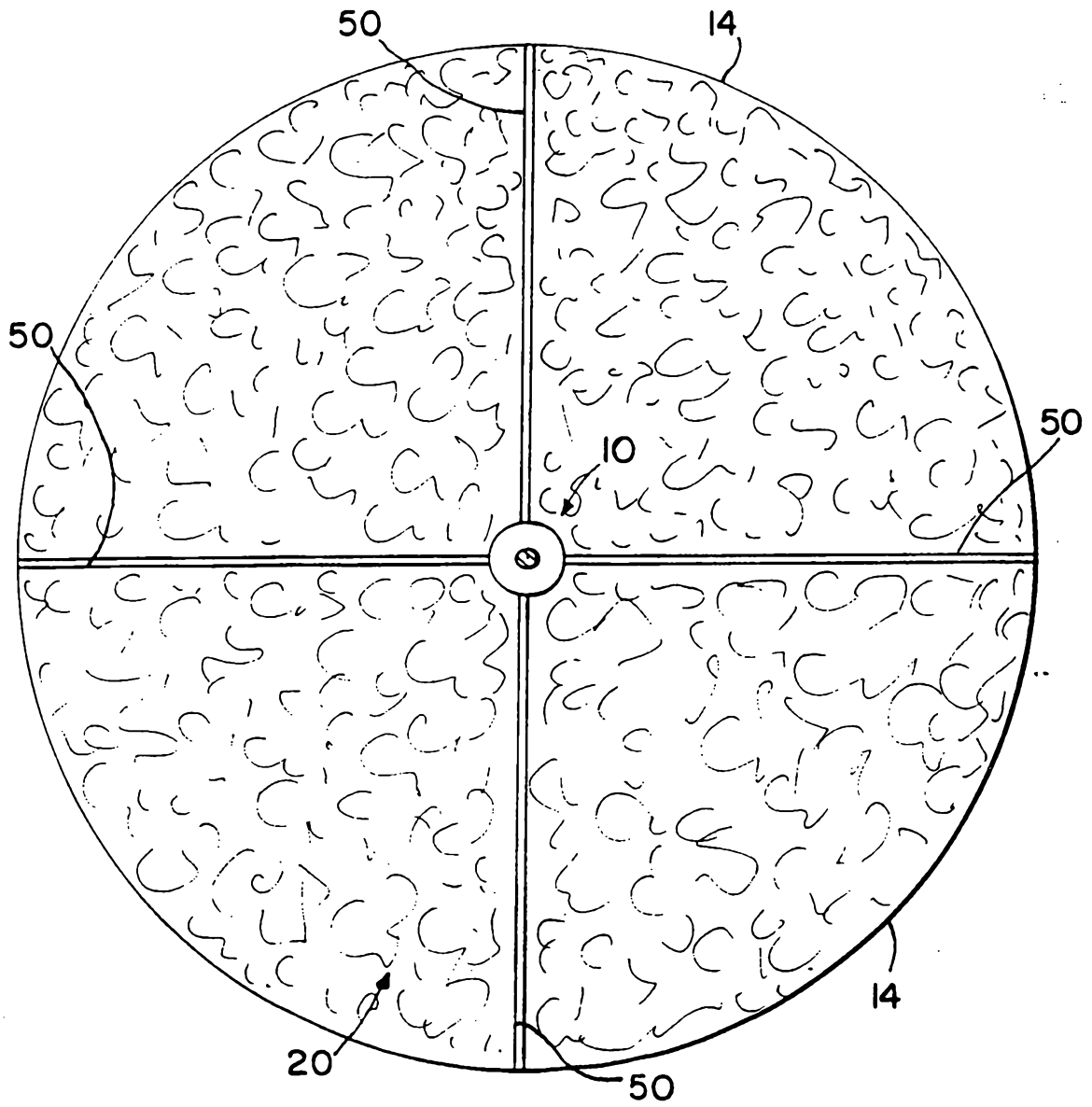


FIG. 4

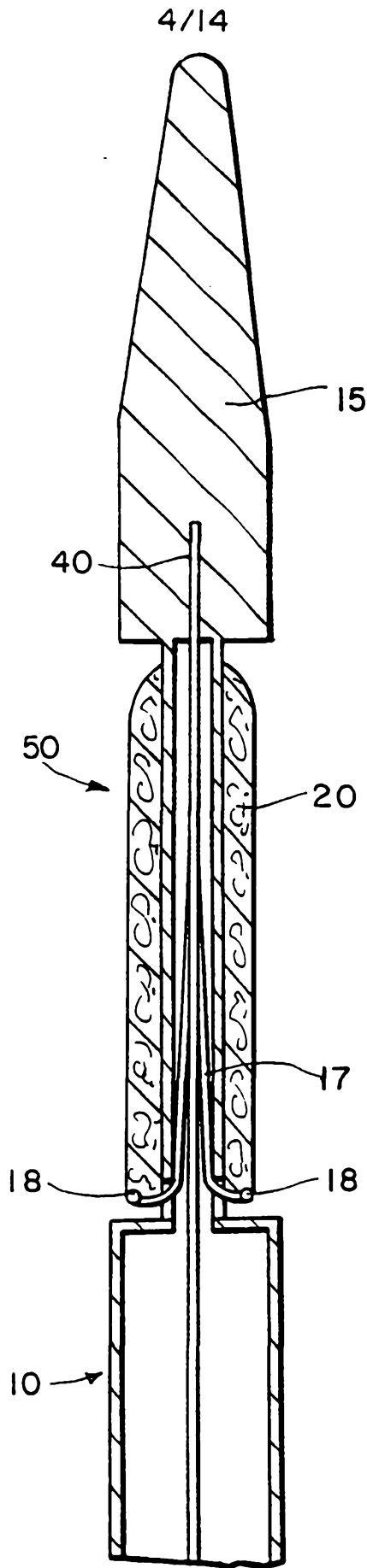
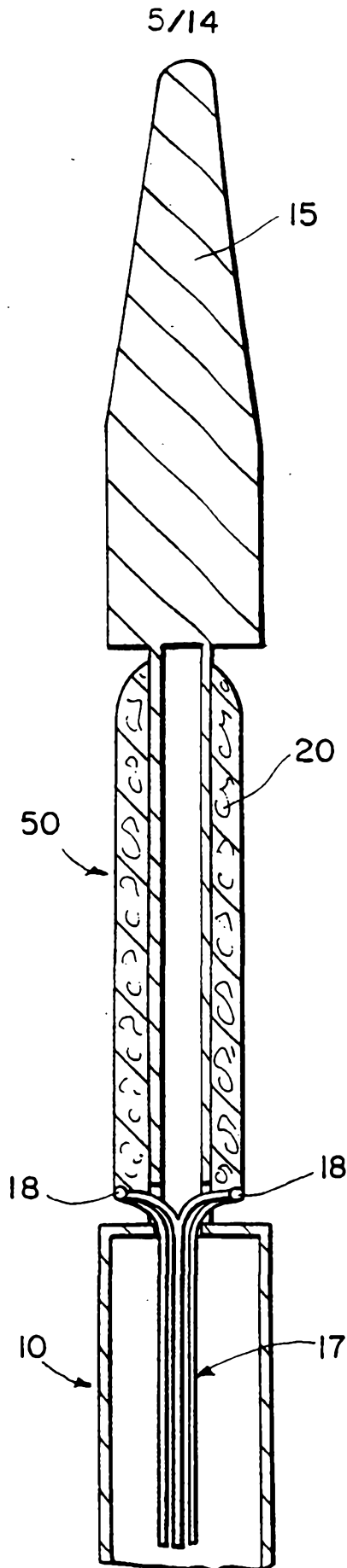
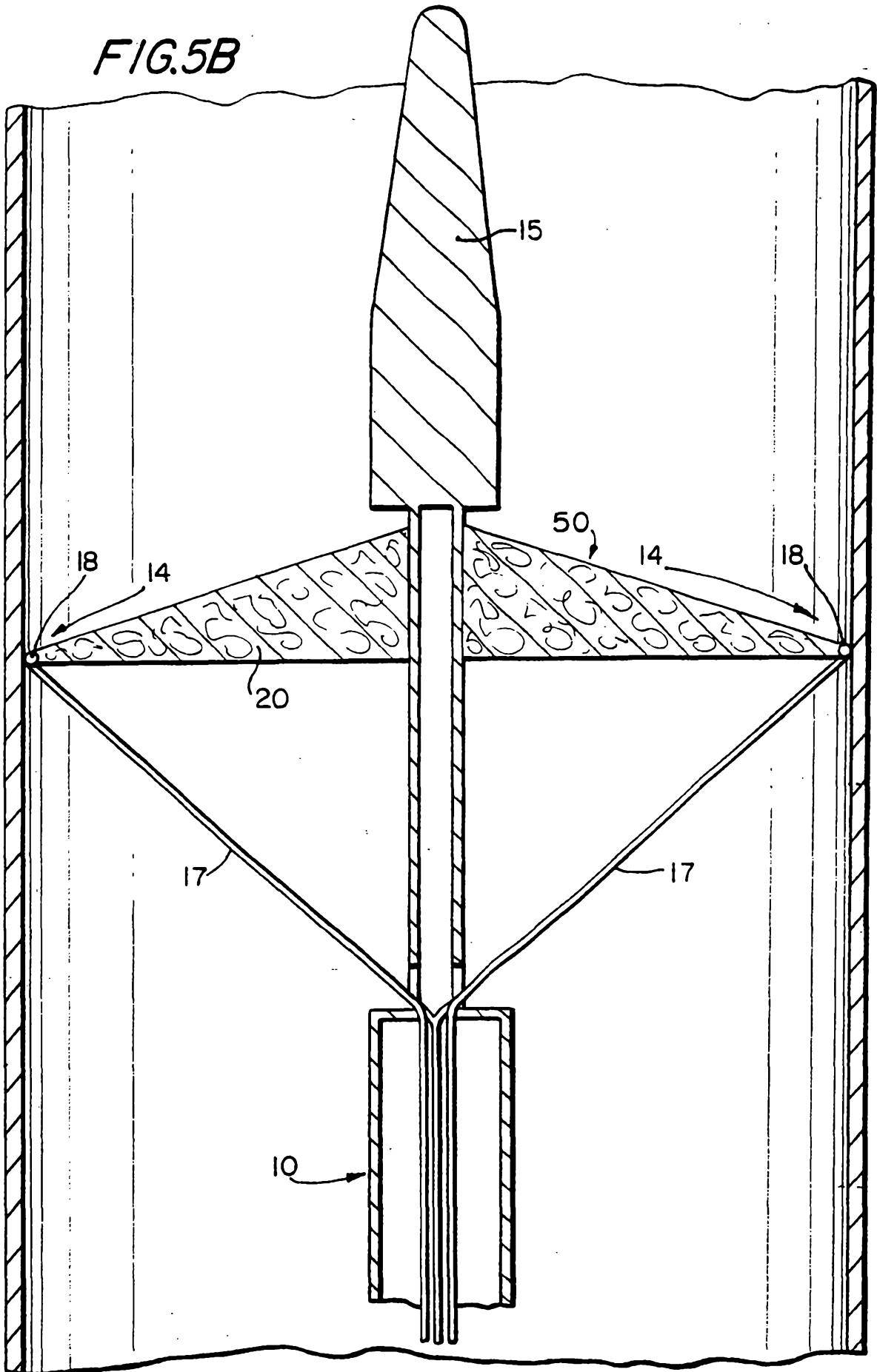


FIG.5A



6/14

FIG. 5B



7/14

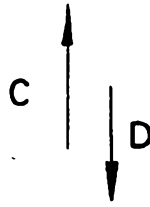
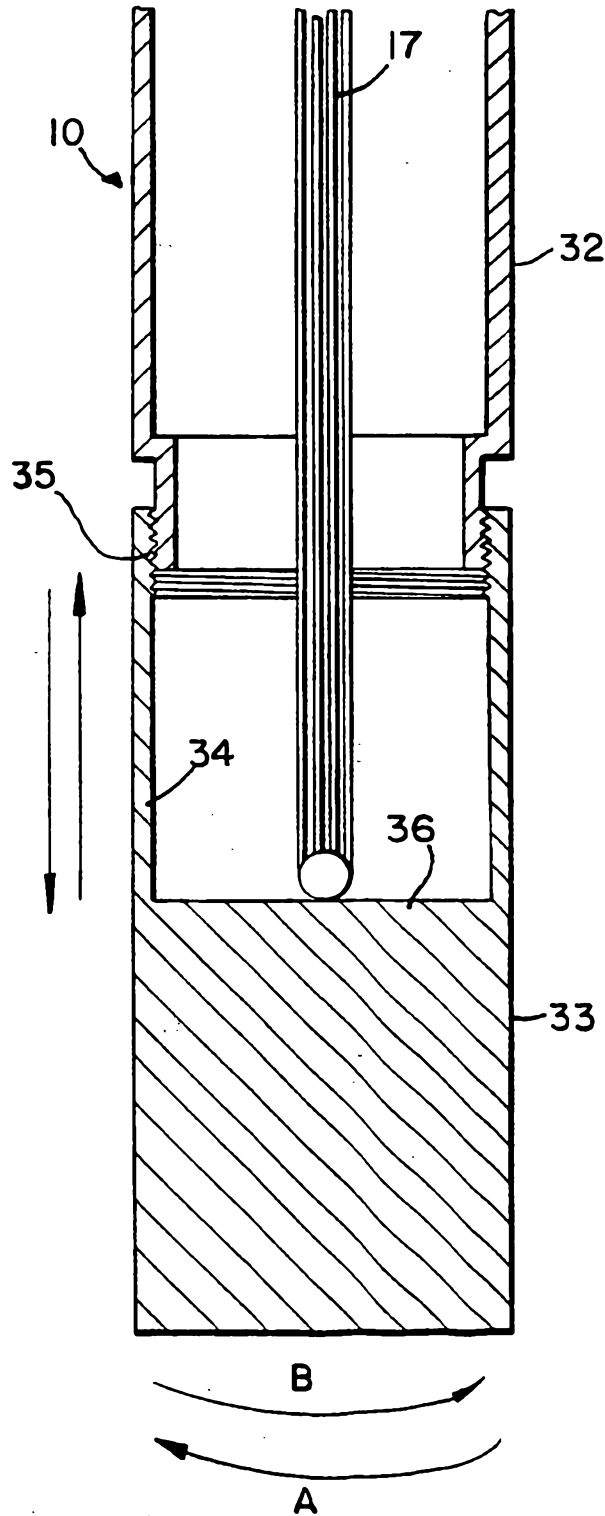
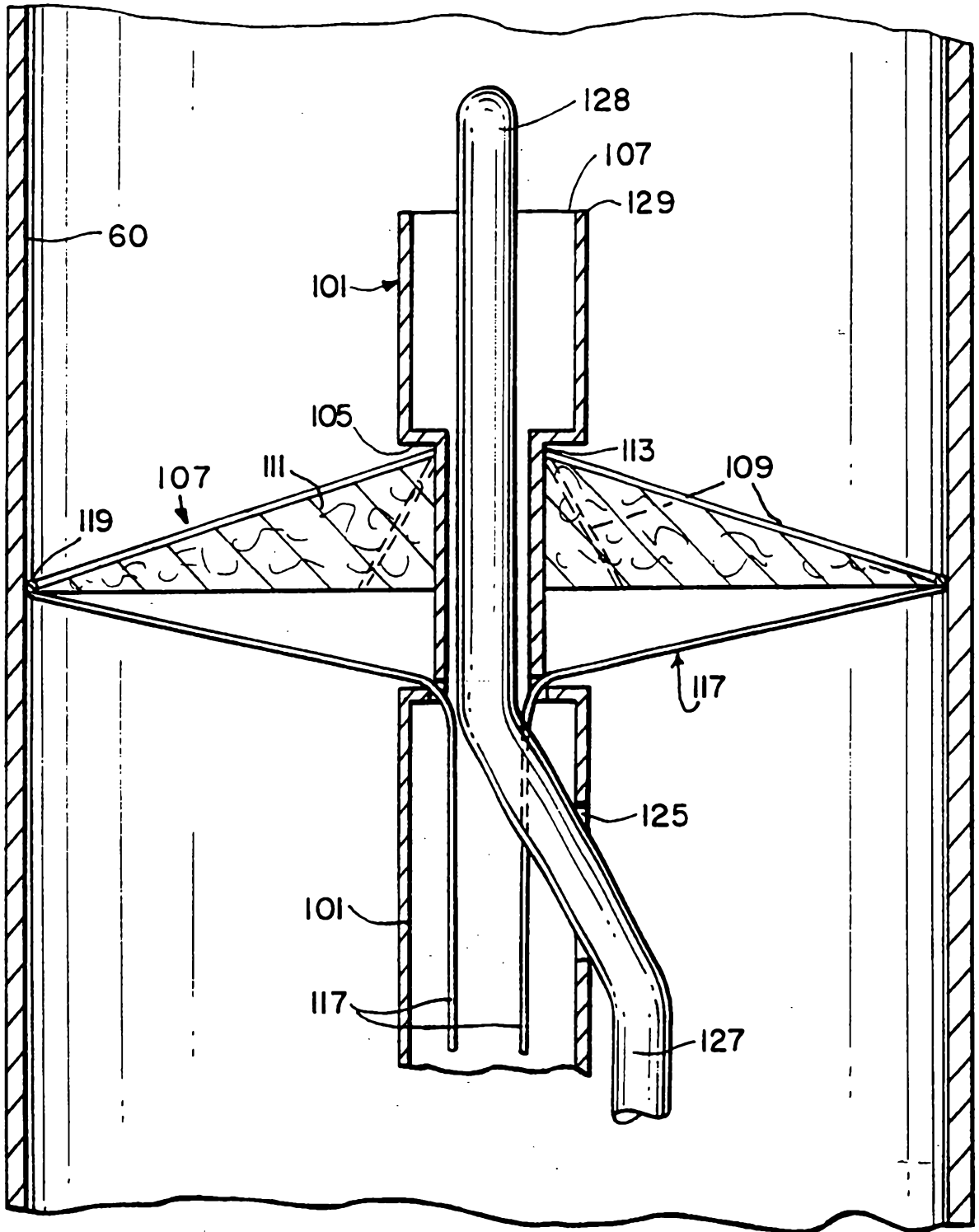


FIG.6

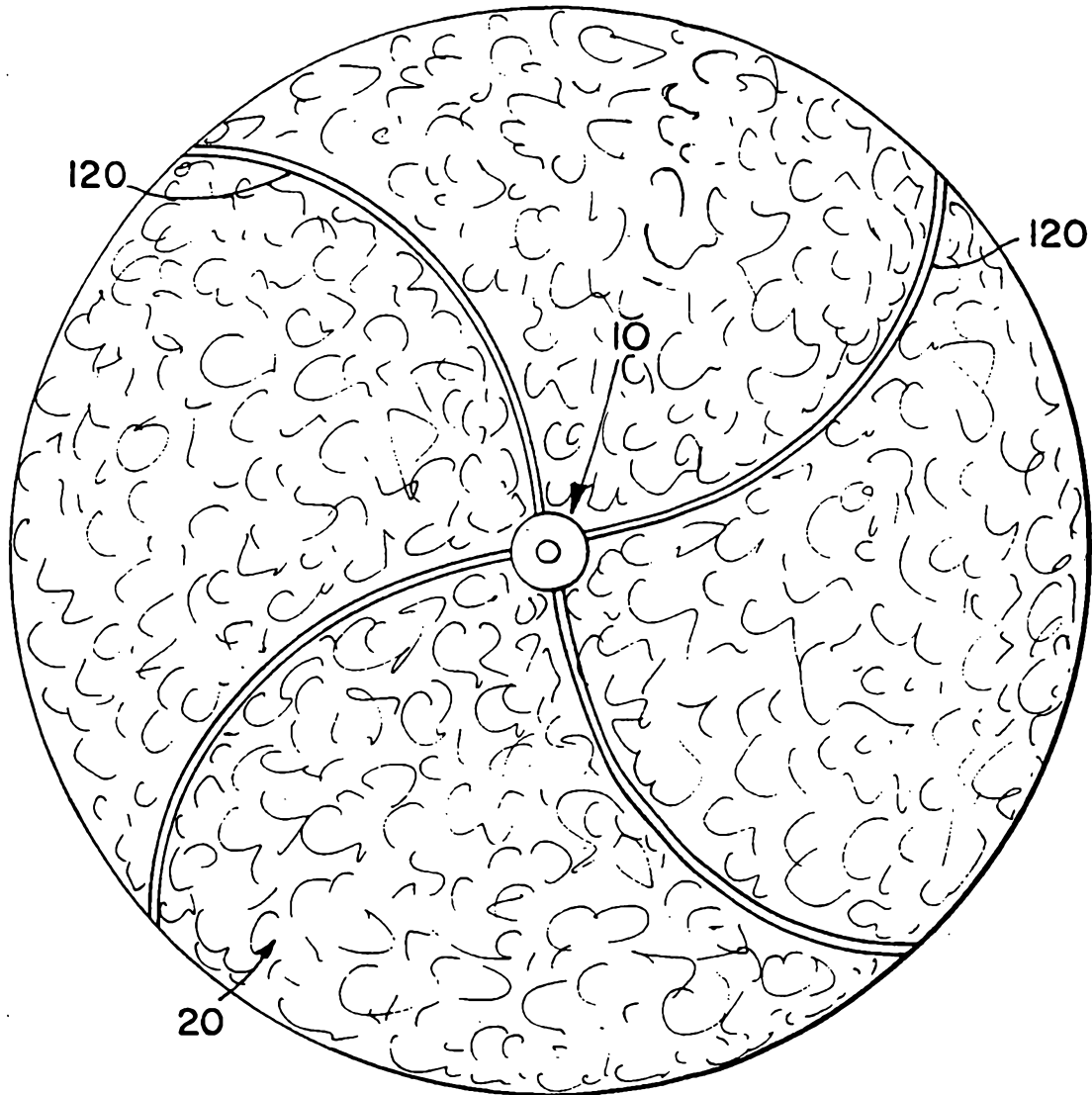


8/14
FIG. 7



9/14

FIG. 8



10/14

FIG. 9

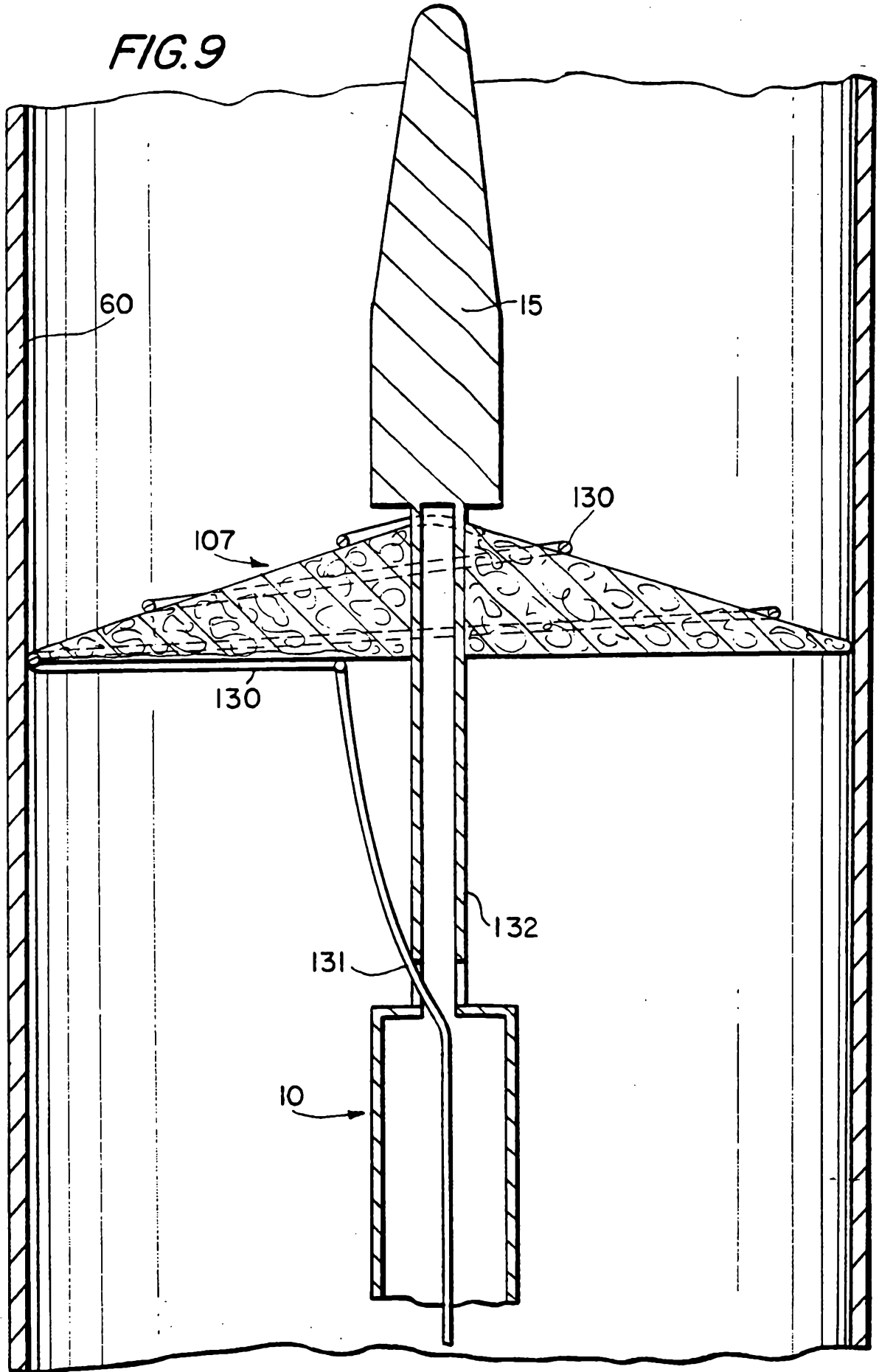


FIG. 10

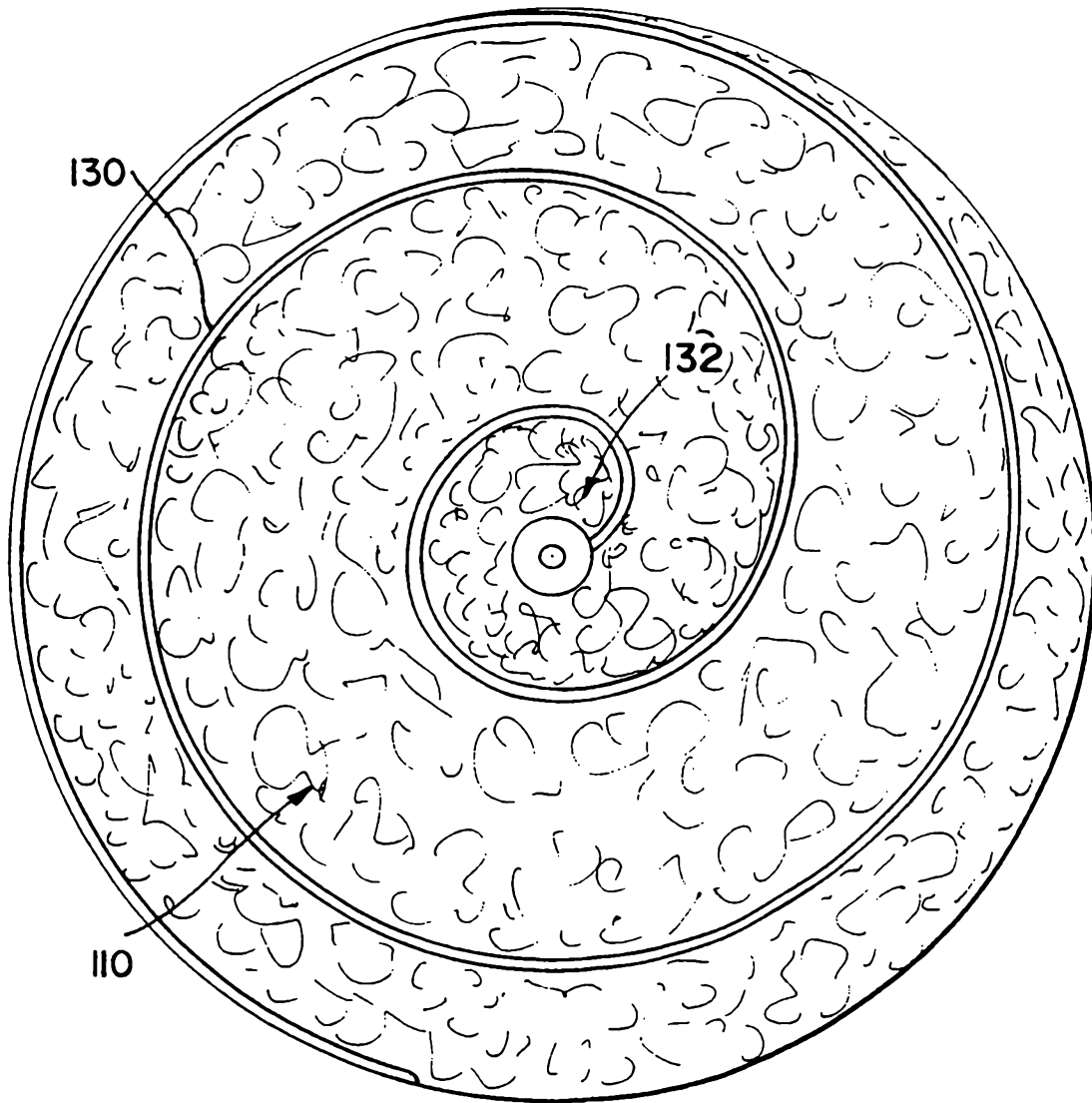


FIG. II

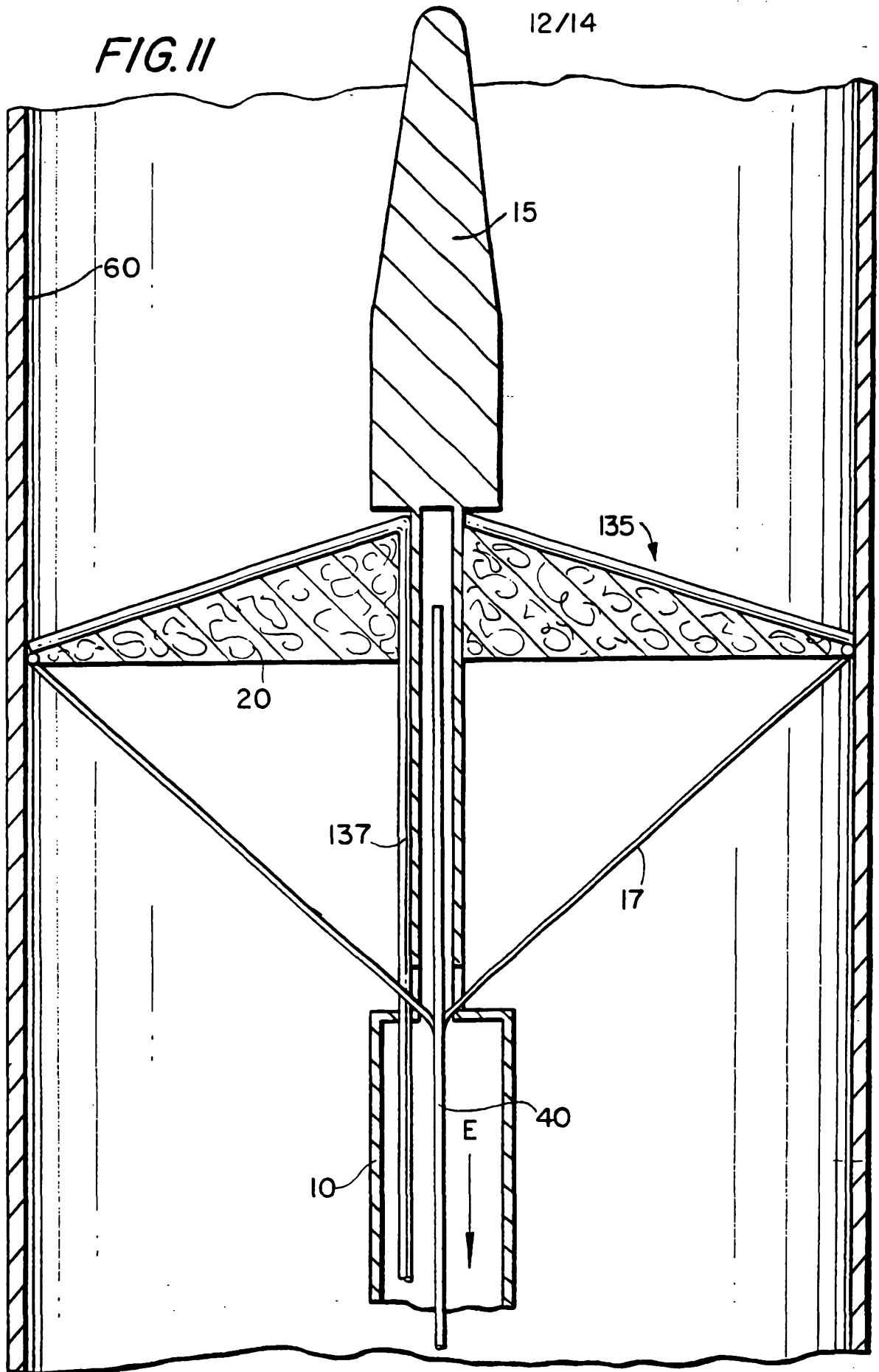
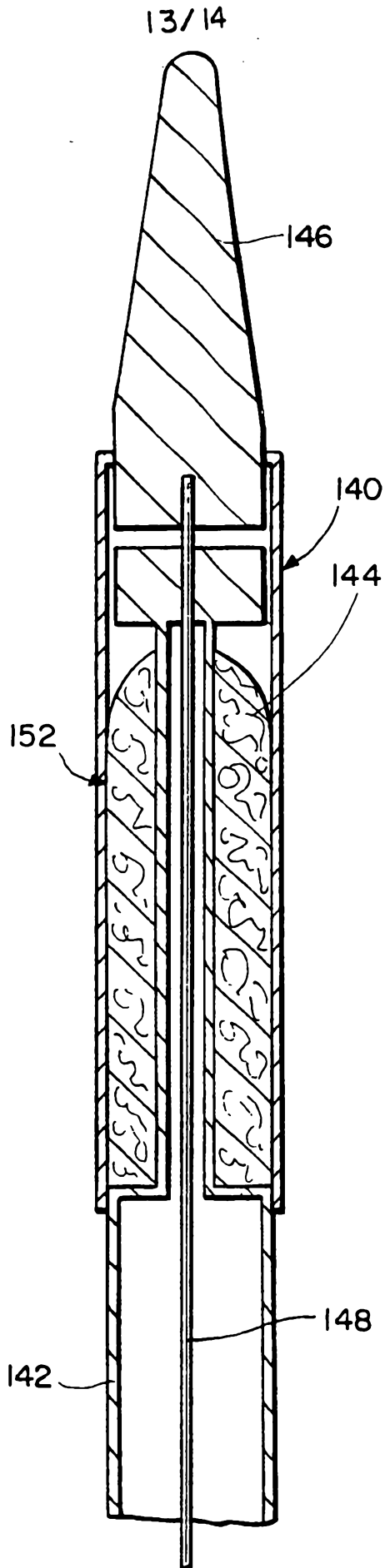


FIG. 12



14/14

FIG. 13

