



(12) **United States Design Patent**
Styrc et al.

(10) **Patent No.:** **US D936,244 S**
(45) **Date of Patent:** **** Nov. 16, 2021**

- (54) **CONNECTOR FOR MODULAR STRUCTURE**
- (71) Applicant: **2724889 ONTARIO INC.**, Oakville (CA)
- (72) Inventors: **Jacek Styrc**, Oakville (CA); **Sebastian Lysiak**, Bielsko-Biata (PL)
- (73) Assignee: **2724889 ONTARIO INC.**, Oakville (CA)
- (**) Term: **15 Years**
- (21) Appl. No.: **29/723,176**
- (22) Filed: **Feb. 5, 2020**

Related U.S. Application Data

- (60) Division of application No. 29/635,278, filed on Jan. 30, 2018, now Pat. No. Des. 887,025, which is a continuation-in-part of application No. 15/815,973, filed on Nov. 17, 2017, now abandoned.
 - (51) **LOC (13) Cl.** **25-01**
 - (52) **U.S. Cl.**
USPC **D25/133**
 - (58) **Field of Classification Search**
USPC D25/119, 125, 126, 127, 128, 129, 130, D25/131, 132, 133, 134, 135, 136; D8/349, 354, 382, 383, 384; D21/468, D21/471, 478, 479
CPC A47B 47/0008; A47B 47/03; E01B 11/24; E02D 27/42; E04B 1/4157; E04B 1/58; E04B 1/617; E04B 2001/4192; E04B 2/56; E04B 2/70; E04B 1/1912; E04B 1/2688; E04B 2001/1963; E04B 2001/199; E04B 2001/1993; E04B 2001/266; E04B 2001/2676; E04B 2001/1984; E04F 13/0823; E04F 10/02; E04G 21/185; E04G 7/02; E04G 7/22; E04H 12/187; E04H 12/2253; F16B 12/40; A45F 3/24; F16M 11/24
- See application file for complete search history.

(56) **References Cited**

U.S. PATENT DOCUMENTS

451,596 A	5/1891	Longenecker
490,122 A	1/1893	Magargal
922,215 A	5/1909	Tuteur

(Continued)

FOREIGN PATENT DOCUMENTS

CA	3007687 A1	12/2018
CN	201542095 U	8/2010

(Continued)

OTHER PUBLICATIONS

Hammock Hanger for 4x4 Wood Posts <https://tojagrid.com/collections/brackets/products/grid-hanger> Date Unknown.*

(Continued)

Primary Examiner — Samantha Q Lawrence
(74) *Attorney, Agent, or Firm* — Bhole IP Law; Anil Bhole; Marc Lampert

(57) **CLAIM**

The ornamental design for a connector for a modular structure, substantially as shown and described.

DESCRIPTION

FIG. 1 is a perspective view of the connector; FIG. 2 is a rear elevation of the connector of FIG. 1; FIG. 3 is a front elevation of the connector of FIG. 1; FIG. 4 is a plan view of the connector of FIG. 1; FIG. 5 is a bottom view of the connector of FIG. 1; FIG. 6 is a side elevation of the connector of FIG. 1; and, FIG. 7 is a side elevation from the opposite side to FIG. 6 of the connector of FIG. 1.

1 Claim, 7 Drawing Sheets

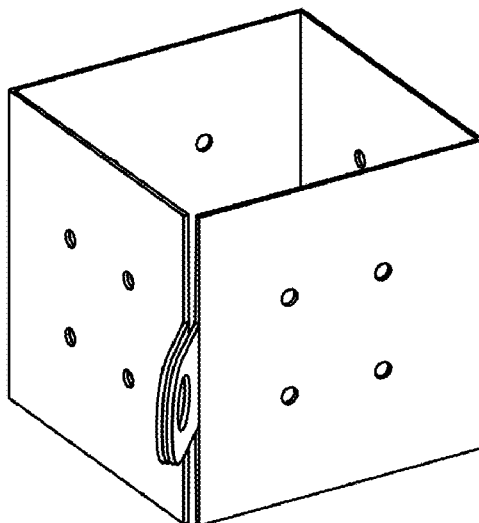

(56)

References Cited

U.S. PATENT DOCUMENTS

949,394 A	2/1910	Daly	5,238,321 A	8/1993	Jarjoura
1,097,934 A	5/1914	Price	5,259,685 A	11/1993	Gilb
1,201,159 A	10/1916	Dettmer	D342,328 S	12/1993	Granstrom
1,214,738 A	2/1917	Wolf	D342,662 S	12/1993	Lavin, Sr. et al.
1,441,559 A	1/1923	Jacob	5,284,311 A	2/1994	Baer
1,816,049 A	7/1931	Larner	5,375,384 A	12/1994	Wolfson
1,818,418 A	8/1931	Millard	D355,349 S	2/1995	Taparauskas
1,848,085 A	3/1932	Eisenschmidt	D356,646 S	3/1995	Cole
2,016,702 A	10/1935	Harry	RE34,892 E	4/1995	Dunwoodie
2,037,736 A	4/1936	Payne et al.	D361,462 S	8/1995	Newham
2,153,547 A	4/1939	Charlop	D365,714 S	1/1996	Masello
2,225,599 A	12/1940	Zillig	5,490,523 A	2/1996	Mallookis
D141,423 S	5/1945	Lewis	D370,681 S	6/1996	Diamond
2,477,163 A	7/1949	Barnett	5,555,681 A	9/1996	Cawthorn
D178,316 S	7/1956	Vegors	5,556,218 A	9/1996	Homer
2,869,693 A	1/1959	Wood	D374,937 S	10/1996	Salas
2,931,129 A	4/1960	Boniface	5,590,974 A	1/1997	Yang
3,188,696 A	6/1965	Earhart	D398,219 S	9/1998	Campman
3,229,004 A	1/1966	Lewine	5,941,183 A	8/1999	Ming-Shun
3,278,149 A	10/1966	Brucker	5,941,527 A	8/1999	Selton
3,310,324 A	3/1967	Boden	D426,041 S	5/2000	Boghossian
3,352,491 A	11/1967	Nelson	D427,810 S	7/2000	Ali et al.
3,369,333 A	2/1968	Wheeler	6,092,342 A	7/2000	Sharapata
3,462,021 A	8/1969	Hawke	6,109,461 A	8/2000	Kluge et al.
3,537,221 A	11/1970	Helfman et al.	D430,789 S	9/2000	Opperman
3,545,796 A	12/1970	Nicholls	D434,880 S	12/2000	McNary et al.
3,615,110 A	10/1971	Fugate	D439,246 S	3/2001	Hansen
3,645,569 A	2/1972	Reilly	D442,236 S	5/2001	Chang
3,740,084 A	6/1973	Tellberg	6,230,466 B1	5/2001	Pryor
D232,201 S	7/1974	Hoffman	6,247,869 B1	6/2001	Lichvar
3,829,999 A	8/1974	Bernstein	D444,816 S	7/2001	Stravitz
3,907,445 A	9/1975	Wendt	6,336,620 B1	1/2002	Belli
3,945,741 A	3/1976	Wendt	6,354,451 B1	3/2002	Holst
3,989,398 A	11/1976	Wendt	D455,643 S	4/2002	Aubin
D245,649 S	9/1977	Hughes	6,463,711 B1	10/2002	Callies
4,046,186 A	9/1977	Nordstrom	D465,646 S	11/2002	Hendrickson
4,046,295 A	9/1977	Eichler	6,536,179 B2	3/2003	Little
4,076,431 A	2/1978	Burvall	6,636,620 B1	10/2003	Hoshino
D250,240 S	11/1978	Braginetz	D492,040 S	6/2004	Kozak
D250,241 S	11/1978	Braginetz	6,745,521 B1	6/2004	Klemming
4,125,973 A	11/1978	Lendrihas	6,751,921 B1	6/2004	Iwakawa
4,125,984 A	11/1978	Jonas	D493,091 S	7/2004	Griggy
4,133,151 A	1/1979	Burvall	D508,572 S	8/2005	Suggate
D251,018 S	2/1979	Lockwood	6,969,211 B2	11/2005	Altman
D258,194 S	2/1981	Stanley	7,014,383 B2	3/2006	Schmid et al.
4,313,688 A	2/1982	Daniels	7,231,954 B2	6/2007	Green
D264,481 S	5/1982	Russo	D547,863 S	7/2007	Heinsch
4,381,629 A	5/1983	Ahn	D548,064 S	8/2007	Norton
4,422,792 A	12/1983	Gilb	7,264,416 B2	9/2007	Kahl
4,429,730 A	2/1984	Elston	D558,041 S	12/2007	Skinner
D275,264 S	8/1984	Wegener	7,464,513 B2	12/2008	Rioux
D277,819 S	3/1985	Crosslen	D598,734 S	8/2009	Miranda et al.
D280,466 S	9/1985	Seltzer et al.	7,600,348 B1	10/2009	Kostka
4,572,695 A	2/1986	Gilb	D610,717 S	2/2010	Lin
4,594,017 A	6/1986	Hills	D619,879 S	7/2010	McCarthy et al.
4,616,950 A	10/1986	Morris	7,762,042 B2	7/2010	Packard
4,630,550 A	12/1986	Weitzman	D622,864 S	8/2010	Bajrami
D289,605 S	5/1987	Lytle	D650,987 S	12/2011	Rothbauer
4,665,672 A	5/1987	Commins et al.	D658,491 S	5/2012	Raber
4,717,279 A	1/1988	Commins	D665,656 S	8/2012	Anzelmo
D294,805 S	3/1988	Boyer	8,234,826 B1	8/2012	Proffitt
4,801,121 A	1/1989	Zunker	D673,306 S	12/2012	Min-Ju
4,856,252 A	8/1989	Cornell	8,429,857 B2	4/2013	Melose
4,885,883 A	12/1989	Wright	D689,045 S	9/2013	Mardas
4,910,939 A	3/1990	Cavanagh	D689,207 S	9/2013	Benet
4,919,394 A	4/1990	Otte et al.	8,572,905 B1	11/2013	Driggers
4,925,141 A	5/1990	Classen	D701,108 S	3/2014	Rodgers
D310,760 S	9/1990	Murphy	8,689,494 B2	4/2014	Leavitt
4,991,726 A	2/1991	Johnson	8,720,129 B2	5/2014	Sias et al.
D318,569 S	7/1991	Schaefer	8,739,476 B1	6/2014	Royer
5,033,901 A	7/1991	Dias	8,769,887 B2	7/2014	Proffitt
5,104,252 A	4/1992	Colonias et al.	8,870,163 B2	10/2014	Regan
5,150,982 A	9/1992	Gilb	8,925,893 B2	1/2015	Biedenweg et al.
5,186,571 A	2/1993	Hentzschel	D726,342 S	4/2015	Rodriguez
5,192,056 A	3/1993	Espinueva	D727,143 S	4/2015	Gomez
			9,091,037 B2	7/2015	Fairbairn
			9,102,092 B2	8/2015	Mukith et al.
			D737,670 S	9/2015	Beyerle et al.
			9,144,291 B2	9/2015	Huang

(56)

References Cited

U.S. PATENT DOCUMENTS

D744,319 S 12/2015 White
 9,228,338 B2 1/2016 Lin
 D749,597 S 2/2016 Wengreen
 9,388,540 B2 7/2016 Koering
 D768,466 S 10/2016 Simmons et al.
 D769,470 S 10/2016 Criscione et al.
 D775,512 S 1/2017 White
 D776,965 S 1/2017 Anderson
 D783,390 S 4/2017 Nelson
 9,631,770 B2 4/2017 Holistine
 D786,001 S * 5/2017 Cassidy D6/718.11
 D805,218 S 12/2017 Malone
 9,856,640 B2 1/2018 Shuhaibar
 D820,359 S 6/2018 Deemer
 D822,454 S 7/2018 Kanter
 D824,399 S 7/2018 Wengreen
 10,024,046 B2 7/2018 Higginbotham
 10,030,408 B2 7/2018 Crandall et al.
 D825,967 S 8/2018 Tolokan et al.
 D826,695 S 8/2018 Bolster
 D827,414 S 9/2018 MacDonald et al.
 D832,858 S 11/2018 Wengreen
 D834,396 S 11/2018 MacDonald
 D835,973 S 12/2018 Bertato
 10,202,766 B1 2/2019 Fox
 D842,684 S 3/2019 House
 D843,823 S 3/2019 Bouchard
 D843,932 S 3/2019 Sinai et al.
 D845,113 S 4/2019 Salter
 D845,116 S 4/2019 Wokutch
 D845,310 S 4/2019 Wengreen
 D845,959 S 4/2019 Wengreen
 D846,369 S 4/2019 Ni
 D846,370 S 4/2019 Ni
 10,260,227 B2 * 4/2019 Corbett A47B 47/0008
 D852,788 S 7/2019 Kanter
 D854,191 S 7/2019 Sorensen
 D854,710 S 7/2019 Hendry
 D856,282 S 8/2019 Pillsbury
 D856,781 S 8/2019 Hendry et al.
 D859,958 S 9/2019 Ni
 10,422,140 B2 9/2019 Mitchell
 D866,465 S 11/2019 Harrison
 10,480,177 B2 11/2019 Siddhartha et al.
 D870,544 S 12/2019 Lai et al.
 10,518,596 B2 12/2019 Aitoh et al.
 10,597,899 B2 3/2020 Crandall et al.
 10,640,969 B2 * 5/2020 Grosch E04B 1/1912
 10,697,198 B2 6/2020 Crandall et al.
 10,760,298 B2 9/2020 Crandall et al.
 D900,199 S 10/2020 Rogers
 D901,929 S 11/2020 McCune et al.
 D905,067 S 12/2020 Wengreen
 D905,068 S 12/2020 Wengreen
 D905,069 S 12/2020 Wengreen
 10,858,819 B2 * 12/2020 Styrac F16M 11/24
 D912,496 S 3/2021 Fox
 D915,186 S 4/2021 Barker
 10,975,584 B2 4/2021 Brownmiller et al.
 D918,010 S 5/2021 Lynn et al.
 D920,728 S 6/2021 Scott
 D929,611 S 8/2021 Styrac et al.
 11,098,476 B2 8/2021 Jin et al.
 2003/0101677 A1 6/2003 Hewett
 2004/0170471 A1 9/2004 Wadsworth et al.
 2004/0182430 A1 9/2004 Seo
 2005/0098772 A1 5/2005 Fuoco
 2006/0029462 A1 2/2006 Patberg
 2006/0185706 A1 8/2006 Slade
 2006/0193687 A1 8/2006 Ghosh
 2006/0260259 A1 11/2006 Morse
 2007/0209312 A1 9/2007 Keys et al.
 2007/0209314 A1 9/2007 Vaughn
 2007/0261356 A1 11/2007 Vaughn
 2007/0266647 A1 11/2007 Pedersen et al.

2008/0110583 A1 5/2008 Lallemand
 2008/0178551 A1 7/2008 Porter
 2008/0229678 A1 9/2008 Goddard
 2011/0179741 A1 7/2011 Yen
 2011/0258941 A1 10/2011 Dalo
 2011/0308063 A1 12/2011 Feeleus
 2013/0036702 A1 2/2013 Paceti et al.
 2013/0108394 A1 * 5/2013 Zhu F16B 39/22
 411/366.1
 2013/0232758 A1 8/2013 Pond
 2013/0247499 A1 9/2013 Zimmerman et al.
 2013/0276382 A1 10/2013 Workman
 2013/0306808 A1 11/2013 Huang
 2014/0082921 A1 3/2014 Adams
 2015/0152630 A1 6/2015 Winter
 2015/0328977 A1 11/2015 Lueschen et al.
 2016/0168840 A1 6/2016 Monty et al.
 2017/0089059 A1 3/2017 Farre Berga
 2017/0233996 A1 8/2017 Abernathy et al.
 2017/0314254 A1 11/2017 Houghton et al.
 2018/0135295 A1 5/2018 Bowron
 2018/0135296 A1 5/2018 Brekke
 2018/0230664 A1 8/2018 Dominguez
 2018/0238041 A1 8/2018 Styrac
 2019/0078313 A1 3/2019 Morgan
 2019/0226201 A1 7/2019 Nguyen
 2019/0271146 A1 9/2019 Fox
 2019/0277022 A1 9/2019 Francis
 2020/0375366 A1 12/2020 Chen

FOREIGN PATENT DOCUMENTS

EP 2492408 A1 8/2012
 EP 3456990 A1 3/2019
 FR 2300863 A1 9/1976
 FR 2579720 A1 10/1986
 FR 2991304 A1 12/2013
 GB 422765 A 1/1935
 GB 910183 A 11/1962
 JP S48-023231 4/1973
 JP S48-32322 4/1973
 JP S5217102 U 2/1977
 JP S58-061816 4/1983
 JP 1997268655 10/1997
 RU 73909 U1 6/2008
 WO 201656696 A1 4/2016
 WO 2016178637 A1 11/2016
 WO 2019048362 3/2019
 WO 2021094982 5/2021

OTHER PUBLICATIONS

Notice of Allowance for U.S. Appl. No. 29/635,278, United States Patent & Trademark Office, dated May 7, 2020.
 Notice of References for U.S. Appl. No. 29/635,278, United States Patent & Trademark Office, dated May 7, 2020.
 International Search Report of the International Searching Authority for PCT/CA2018/050169, Canadian Intellectual Property Office, Lily Truong, Canada, dated Jun. 21, 2018.
 Office action for U.S. Appl. No. 15/815,973, United States Patent & Trademark Office, dated Aug. 15, 2018.
 Office action for U.S. Appl. No. 15/815,973, United States Patent & Trademark Office, dated Mar. 19, 2019.
 Office action for U.S. Appl. No. 16/485,272, United States Patent & Trademark Office, dated Dec. 19, 2019.
 Office action for U.S. Appl. No. 29/635,278, United States Patent & Trademark Office, dated Sep. 17, 2019.
 Office Action for United States U.S. Appl. No. 15/815,973, United States Patent and Trademark Office, Ford, Gisele D., dated Nov. 17, 2017.
 Written Opinion of the International Searching Authority for PCT/CA2018/050169, Canadian Intellectual Property Office, Lily Truong, Canada, dated Jun. 21, 2018.
 Office action for U.S. Appl. No. 29/635,278, United States Patent & Trademark Office, dated Feb. 14, 2020.

(56)

References Cited

OTHER PUBLICATIONS

Pergola CUBIC 3-way corner bracket for 7x7 cm post-beam <https://www.vinuovo.com/en/ pergola-cubic-way-corner-bracket-for-7x7-94058077.html#reviews> Aug. 1, 2019 (Year: 2019).

Toja Grid TRIO 2 Pack for 6x6 Wood G0210360-2 <https://www.patioproducts.com/toja-grid-trio-2-pack-for-6x6-wood-g0210360-2.html> Date Unknown.

Extended European Search Report for 18757067.6, European Patent Office, dated Jul. 23, 2020.

Office Action for U.S. Appl. No. 29/746,181, United States Patent and Trademark Office, dated Jul. 20, 2021.

“Office Action for JP 2021-002873”, Japanese Patent Office, dated Jun. 3, 2021.

“Office Action for JP 2021-002874”, Japanese Patent Office, dated Jun. 3, 2021.

“Office Action for JP 2021-002875”, Japanese Patent Office, dated Jun. 3, 2021.

“Office Action for JP 2021-002876”, Japanese Patent Office, dated Jun. 3, 2021.

“Office Action for JP 2021-002877”, Japanese Patent Office, dated Jun. 3, 2021.

“Office Action for JP 2021-002878”, Japanese Patent Office, dated Jun. 3, 2021.

“Russian Patent Office, Office Action dated Jul. 6, 2021 for application No. 2019128908”.

Li, Hui, “First Notification of Office Action”, CN patent application 201880024165.9.

* cited by examiner

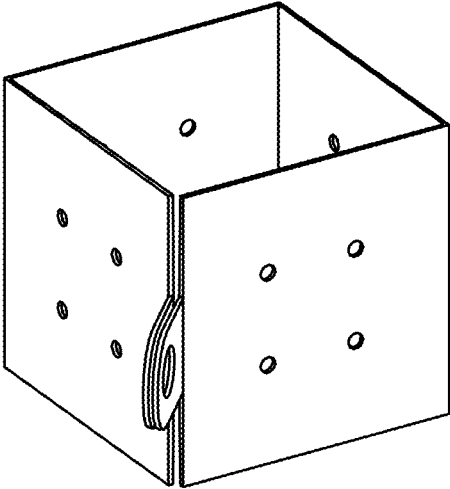

FIG. 1

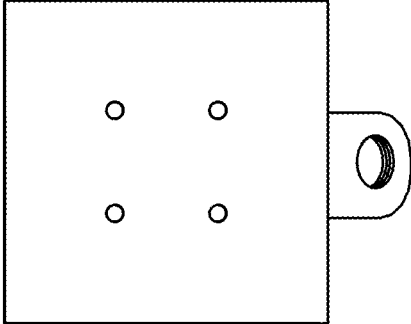

FIG. 2

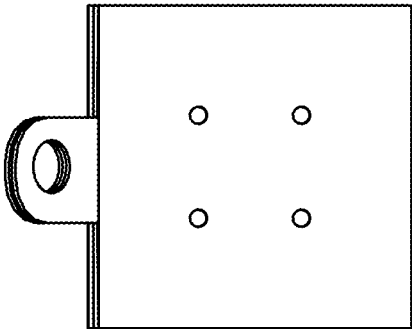

FIG. 3

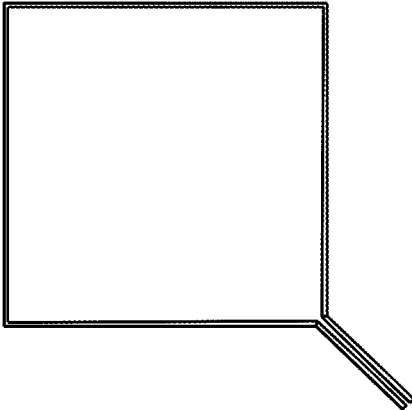

FIG. 4

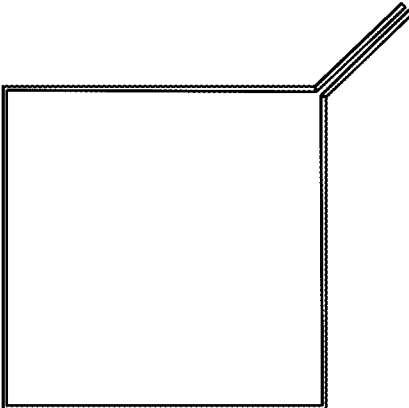

FIG. 5

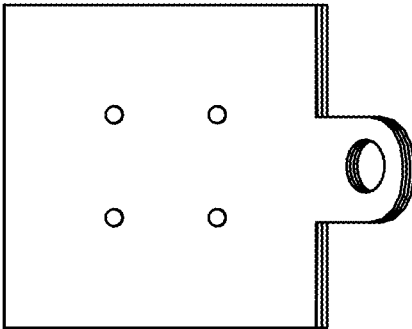

FIG. 6

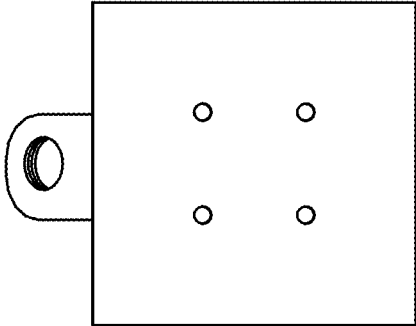

FIG. 7