

I. F. C. CURTIS.
 WATER HEATER.
 APPLICATION FILED OCT. 8, 1909.

1,002,371.

Patented Sept. 5, 1911.

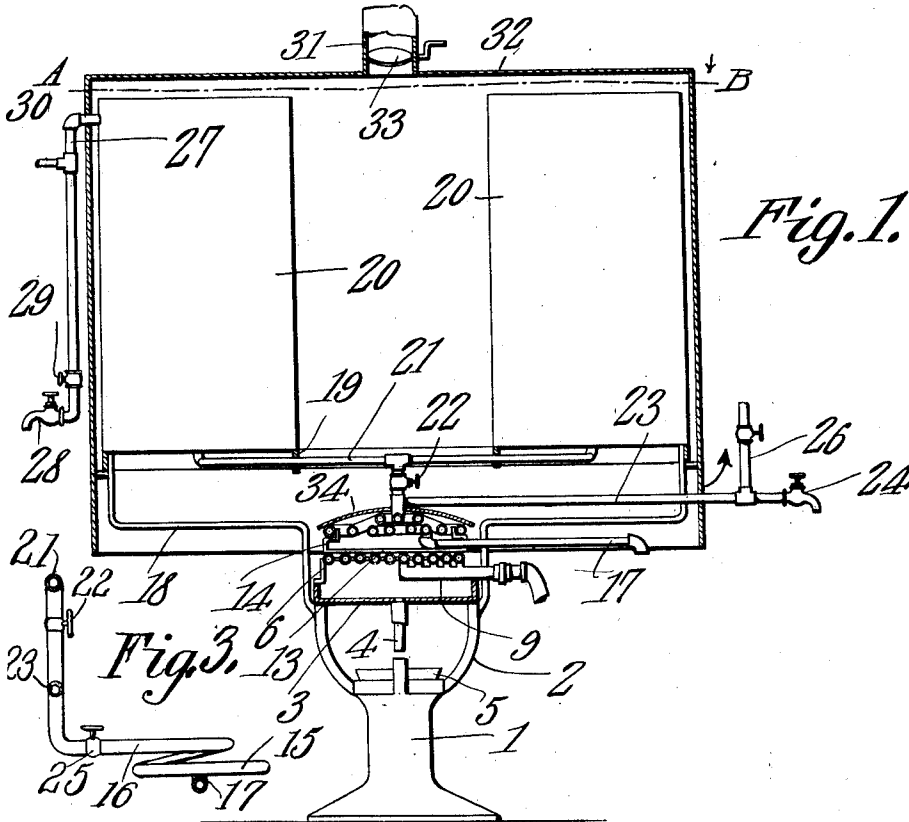

Fig. 1.

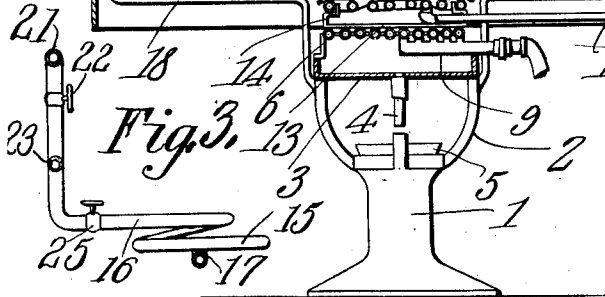

Fig. 3.

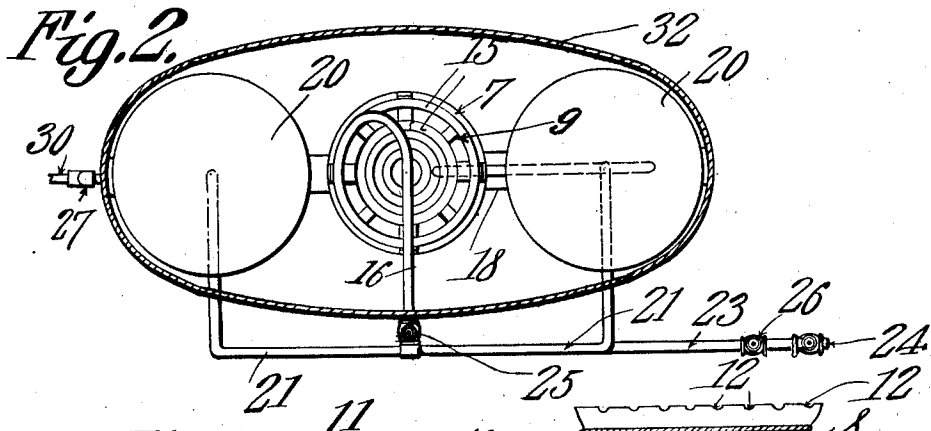

Fig. 2.

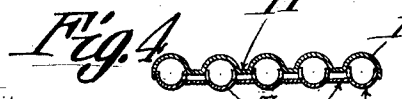

Fig. 4.



Fig. 5.

Witnesses
 E. J. Lamb
 Robert D. Lawson

Inventor
 Ida F. C. Curtis.
 By C. Snow & Co.
 Attorneys

UNITED STATES PATENT OFFICE.

IDA FLORENCE C. CURTIS, OF DAYTON, OHIO.

WATER-HEATER.

1,002,371.

Specification of Letters Patent.

Patented Sept. 5, 1911.

Application filed October 3, 1909. Serial No. 521,659.

To all whom it may concern:

Be it known that I, IDA F. C. CURTIS, a citizen of the United States, residing at Dayton, in the county of Montgomery and State of Ohio, have invented a new and useful Water-Heater, of which the following is a specification.

This invention relates to water heaters of that type better known as "instantaneous heaters."

One of the objects of the invention is to provide a compact device of this character including one or more tanks constituting storage means and whereby a plentiful supply of hot water can be readily obtained immediately after the burner has been lighted.

Another object is to provide an attractive device of this class which can be readily set up close to a bath tub or the like and having means whereby hot water can be supplied directly from either the coil or the tank which is supplied from the coil.

With these and other objects in view, the invention consists in certain novel details of construction and the combinations of parts hereinafter more fully described and pointed out in the claims.

In the accompanying drawings the preferred form of the invention has been shown.

In said drawings:—Figure 1 is a central vertical section through a heater embodying the present improvement. Fig. 2 is a horizontal section through the top portion of the hood or casing and showing the balance of the mechanism in plan, said section being on the line A—B, Fig. 1. Fig. 3 is a vertical section through a portion of the apparatus and showing the outlet pipe of the water coil in side elevation. Fig. 4 is a section through a portion of the burner. Fig. 5 is a longitudinal section through a portion of one of the rings of the burner, the top portion thereof being removed.

Referring to the figures by characters of reference, 1 designates a base or pedestal having upstanding arms 2 supporting a drip pan 3. A drain pipe 4 extends downward from the center of the drip pan and is designed to direct accumulated moisture into a pan 5 which is mounted on the pedestal 1 as shown in Fig. 1. Angular legs 6 extend downward from a burner 7 of novel construction, said burner being made up of concentric rings 8, each of which is preferably substan-

tially semicircular in cross section, all of the rings being connected by means of webs 9 cast integral therewith. The said rings 8 communicate with a supply pipe 9 which can be of any preferred construction and is designed to be attached to a service pipe whereby gas may be readily directed into the rings 8. Each of these rings has a cap 10 also formed of a ring semi-circular in cross section, said rings being connected by means of integral webs 11. The widths of the cap rings 10 are slightly greater than those of the base rings 8 so as to enable said cap rings to lap the peripheral edges of the rings 8. The outer edge of the outer base ring 8 and the inner face of the outer portion of the outer cap ring 10 are screw threaded and designed to interengage when the rings 10 are turned in one direction, this resulting in the securing of all of the rings 10 upon the rings 8. Apertures 12 are formed in the peripheral edges of the inner base rings 8 and also in the inner edge of the outer ring 8, these apertures or notches being only partly covered by the cap rings and therefore constituting outlets for the gaseous fuel. It will be apparent of course that when the cap rings are secured upon the base rings they form tubes or gas chambers. Cross straps 13 are arranged upon the burner formed of the cap rings 10 and base rings 8 and these straps have upstanding brackets 14 at the ends thereof and which support the water coil 15 of the heater. The coil has its outer convolution merging into the discharge pipe 16. The pipe for directing water to the coil has been indicated at 17.

Arms or brackets 18 extend laterally and upwardly from the arms 2 and mounted on these last mentioned arms 18 is a frame 19 supporting one or more closed tanks or receptacles 20. In the present instance, two of these tanks have been shown, the same being spaced apart and arranged above but at opposite sides of the burner and water coil. The outlet pipe 16 of the water coil extends upward and opens into a pipe 21, the end of which opens into the bottom portions of the tanks 20, there being a valve 22 within the pipe 16, whereby the flow of water into the pipes 21 and tank 20 may be cut off if desired. Another pipe 23 extends from the pipe 16 at a point below the valve 22 and terminates in a faucet 24 arranged at any suitable point, there being a valve 25 in the

pipe 16 below pipe 23 for cutting off the supply of water to the faucet from the coil. One or more branch pipes 26 may be extended from the pipe 23. An overflow pipe 5 27 extends from the upper portions of one of the tanks 20 and may be provided with a faucet 28 at the terminus thereof, there being a valve 29 for controlling the flow of water to the faucet. One or more branch pipes 30 10 may be extended from this overflow pipe as shown, to conduct the overflow to any suitable point should the faucet 28 be closed. An outlet flue 31 is extended upward from the top of a hood or casing 32 which incloses 15 the tanks 20 and extends downward to the burner 7, this flue being provided with a damper 33 whereby the escape of the products of combustion can be readily controlled.

In using the device herein described the 20 gaseous fuel is directed into the burner through the feed pipe 9 and the gas will ignite where it escapes through the openings 12 in the base rings 8. The flames will come in direct contact with the convolutions of 25 the water coil and the water contained within this coil will be quickly heated. If the valve 22 is opened, the heated water will flow into the tanks 20 where it will be stored for future use, the said stored water being 30 maintained at a high temperature by the products of combustion passing through the hood or casing 32 to the flue 31. When it is desired to use the water, the valve 22 can be closed and the valve 25 opened whereupon 35 the water is free to pass directly from the water coil to the point of use or, if preferred, the valve 22 can also be opened whereupon an increased supply of water will flow, not only from the coil but also from the tanks. 40 By closing the valve 25 and opening valve 22, the coil may be shut off from the faucet 24 and all the water in tanks 20 will thus be supplied to said faucet. The pipe 27 constitutes a means for permitting any necessary 45 overflow and will also allow steam to escape should the pressure within the tanks become too great. It is of course to be understood that a suitable safety valve should be located at some point, preferably within the pipe 30. 50 A hood 34 may be located directly over the coil 15 to deflect the heat passing there-

through and thus increase the efficiency of the burner.

As heretofore pointed out it will be apparent that by closing the valve 25 and opening 55 valve 22 hot water, which has been stored in the tanks 20, can be drawn off through the faucet 24, said water flowing through pipes 21 and 23 to said faucet. The coil is, of course, at this time out of communication with the faucet. By opening 60 valve 25 and closing the valve 22, water can be caused to flow directly from the coil to the faucet 24 and communication between the tanks 20 and said faucet will be closed. 65

What is claimed is:—

1. In a water heater, the combination with a burner, of a tank thereabove, a water coil supported above the burner, a feed pipe extending to the coil from a source of supply 70 and from said coil to the tank, a valve within said pipe connections between the coil and the tank for controlling the passage of water from the coil to the tank, a pipe extending from said connection between the coil and 75 the valve for conveying water to the point of use from the source of supply and the coil when the valve is closed and from the tank when the valve is opened.

2. A water heater including a burner, 80 spaced closed tanks supported thereabove and forming a flue therebetween said flue being located over the burner, a housing extending over and around the tank and having a top outlet, a water coil interposed between the 85 burner and the said flue, means for directing water to the coil from a source of supply, a pipe connection between the coil and the tanks, an outlet pipe extending from said connection for directing water from either 90 the tanks or the coil to the point of use, and valves for controlling the passage of water to said outlet pipes from the coil and tank respectively.

In testimony that I claim the foregoing as 95 my own, I have hereto affixed my signature in the presence of two witnesses.

IDA FLORENCE C. CURTIS.

Witnesses:

THOMAS DALE,
MAUDE COFFMAN.