



(51) International Patent Classification:

G02B 27/18 (2006.01) G02B 27/10 (2006.01)
B23K 26/064 (2014.01) G02B 3/00 (2006.01)
B33Y 40/00 (2015.01) G02F 1/133 (2006.01)
G02B 27/09 (2006.01)

(21) International Application Number:

PCT/CA2017/000086

(22) International Filing Date:

12 April 2017 (12.04.2017)

(25) Filing Language:

English

(26) Publication Language:

English

(30) Priority Data:

62/321,300 12 April 2016 (12.04.2016) US

(71) Applicant: **MAGNA INTERNATIONAL INC.**
[CA/CA]; 337 Magna Drive, Aurora, Ontario L4G 7K1 (CA).

(72) Inventors: **DEAVILLE, Todd**; 6 Baver Crescent, Markham, Ontario L3R 4H4 (CA). **ABATE, Vito**; 605-109 Front Street East, Toronto, Ontario M5A 4P7 (CA).

(74) Agent: **GOWLING WLG (CANADA) LLP**; Suite 1600, 1 First Canadian Place, 100 King Street West, Toronto, Ontario M5X 1G5 (CA).

(81) Designated States (unless otherwise indicated, for every kind of national protection available): AE, AG, AL, AM,

AO, AT, AU, AZ, BA, BB, BG, BH, BN, BR, BW, BY, BZ, CA, CH, CL, CN, CO, CR, CU, CZ, DE, DJ, DK, DM, DO, DZ, EC, EE, EG, ES, FI, GB, GD, GE, GH, GM, GT, HN, HR, HU, ID, IL, IN, IR, IS, JP, KE, KG, KH, KN, KP, KR, KW, KZ, LA, LC, LK, LR, LS, LU, LY, MA, MD, ME, MG, MK, MN, MW, MX, MY, MZ, NA, NG, NI, NO, NZ, OM, PA, PE, PG, PH, PL, PT, QA, RO, RS, RU, RW, SA, SC, SD, SE, SG, SK, SL, SM, ST, SV, SY, TH, TJ, TM, TN, TR, TT, TZ, UA, UG, US, UZ, VC, VN, ZA, ZM, ZW.

(84) Designated States (unless otherwise indicated, for every kind of regional protection available): ARIPO (BW, GH, GM, KE, LR, LS, MW, MZ, NA, RW, SD, SL, ST, SZ, TZ, UG, ZM, ZW), Eurasian (AM, AZ, BY, KG, KZ, RU, TJ, TM), European (AL, AT, BE, BG, CH, CY, CZ, DE, DK, EE, ES, FI, FR, GB, GR, HR, HU, IE, IS, IT, LT, LU, LV, MC, MK, MT, NL, NO, PL, PT, RO, RS, SE, SI, SK, SM, TR), OAPI (BF, BJ, CF, CG, CI, CM, GA, GN, GQ, GW, KM, ML, MR, NE, SN, TD, TG).

Published:

- with international search report (Art. 21(3))
- before the expiration of the time limit for amending the claims and to be republished in the event of receipt of amendments (Rule 48.2(h))

(54) Title: HIGH-POWER DYNAMIC LENS

FIG. 1A

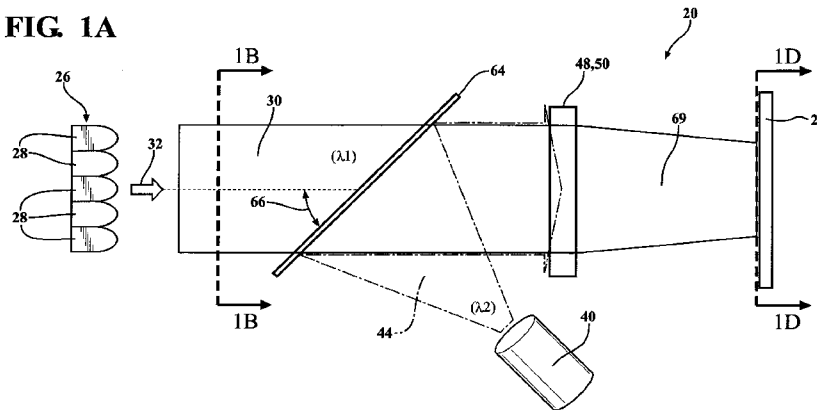

(57) Abstract: A dynamic lens for projecting different output beam shapes includes a first light source of laser diodes generating a first light beam toward a target. A projector generates a second light beam with a different wavelength than the first light beam. A beam combiner combines the first light beam together with the second light beam and directs the combined beams to a focusing plane that includes a lensing array to focus the first light beam into the output beam shape on the target. The lensing array includes a plurality of photoactive cells including at least one photoreactive group which changes molecular shape in response to light energy from the second light beam, thereby changing the orientation of adjacent liquid crystal molecules, which in turn alters the index of refraction of the photoactive cell. A method of operating the dynamic lens to generate the output beam shape is also disclosed.

WO 2017/177310 A1

HIGH-POWER DYNAMIC LENS

CROSS REFERENCE TO RELATED APPLICATION

[0001] This PCT Patent Application claims the benefit of and priority to U.S. Provisional Patent Application Serial No. 62/321,300, filed April 12, 2016, the entire disclosure of the application being considered part of the disclosure of this application, and hereby incorporated by reference.

BACKGROUND OF THE INVENTION

1. Field of the Invention

[0002] A dynamic lens for projecting different output beam shapes upon a target.

2. Discussion

[0003] Lenses are used in various applications including forming a high-power light beam into an output beam shape on a target for applications such as welding and additive manufacturing ("AM"). Such lenses must be able to withstand exposure to high-power light beams through a large number of cycles or pulses throughout the lifetime of the lens. Dynamic type lenses are capable of changing to form a light beam into different shapes. Thus far, dynamic lenses have not been suitable for high-power applications because available dynamic lenses have required electrodes or other fragile materials that are damaged by the high-power light beams passing therethrough.

[0004] Advancements have been made recently in the field of programmable freeform (i.e., dynamic) lenses which employ "a phase modulation pattern to project a pre-defined caustic image on a designated image plane." One such programmable freeform lens arrangement is disclosed in Damberg et al. "Efficient Freeform Lens Optimization for Computational Caustic Displays." Optics Express 23.8 (pub. 13 Apr 2015). Dynamic lenses so far known, including those disclosed in the Damberg et al. article, have employed

traditional Liquid Crystal on Silicon (LCOS) based technology, such as spatial light modulator (SLM) devices used in video projectors, making them unsuitable for high-power applications.

[0005] Adaptive masks have recently been developed that can form a high-power light beam into different output shapes using photoactive liquid crystals. See, for example, Marshall et al. "Computational Chemistry Modeling and Design of Photoswitchable Alignment Materials for Optically Addressable Liquid Crystal Devices." 142 LLE Review at 151 (2015). U.S. Patent Application Publication No. 2014/0252687 (September 11, 2014) discloses a system for performing additive manufacturing ("AM") with a mask that uses liquid crystals to modify the polarization of a portion of a high-power light beam which is then masked by a polarizing mirror, allowing the remainder to pass through to a substrate target.

[0006] Because a portion of the high-power light beam is masked from the target and is, therefore, unavailable for useful work in systems that use adaptive masks, there remains a need for an adaptive lens that is capable of forming substantially all of a high-power light beam passing therethrough into an output beam shape on a target.

[0007] A dynamic lens according to the present invention allows for targets or frames that vary in size within the limits of the size of the lensing array. A dynamic lens also allows for variable power density depending on frame size. This means that frame size may increase as part density decreases. Also, unlike systems that employ adaptive masks, the build rate on AM systems using a dynamic lens is not dependent on part density (frame utilization).

SUMMARY OF THE INVENTION

[0008] The invention provides for a dynamic lens for projecting different output beam shapes upon a target. The dynamic lens includes a first light source generating a first

light beam at a first wavelength. A projector including a second light source generates a second light beam having a second wavelength different from the first wavelength and forms the second light beam to an initial pattern. The dynamic lens also includes a focusing plane including a lensing array of photoactive cells for refracting the first light beam in response to stimulation by the second light beam having the second wavelength, and a beam combiner for combining the first light beam with the second light beam and directing the combined light beams onto the focusing plane. The focusing plane includes a lensing array of photoactive cells that form a phase pattern to form the first light beam into the output beam shape on the target in response to stimulation by the second light beam having the second wavelength according to the initial pattern.

[0009] The invention in its broadest aspect therefore provides for an output beam shape which is dynamically adjustable, meaning its shape and points of focus can be quickly changed. The invention also provides for an output beam with substantially all of the first light beam transmitted to the target. This is an improvement over prior art “masking” type beam former which mask or direct a portion of the first light beam away from the target in order to create a desired beam shape.

[0010] As shown in Table 1, an additive manufacturing process using a masking beam former to make an example “hollow wheel” structure having approximately 18% areal density would take 22 s per layer. Substituting a dynamic lens of the present invention, which directs substantially all of the high-power first light beam to the target, the additive manufacturing process can make the same layer in 5.122 s. This is an improvement of about four (4) times.

TABLE 1 - Hollow Wheel Structure ~18% part areal density

	25 x 25 mm Mask Frame	Variable Lens	
Bound Area	2695	2695	mm ²
Cross-Sectional Area	494	494	mm ²
Fill Factor	18%	18%	mm ²
Bed 500 mm x 1000 mm			
Parts / Build	158	158	
Total Section Area	78052	78052	mm ²
Frame Area	625	4003.7411	mm ²
Frames Required	800	124.8832	
Frame Pixels	1,000,000	6,405,986	@ 25 micron
Cross-Section Mass	0.09633	0.09633	g
Layer Thickness	25	25	micron
Material	Steel	Steel	
Frame Time	0.025	0.025	s
Power Sweep Time	2	2	s
Max Mat'l Area/Frame	625	625	mm ²
Part Area/Frame	114.5640074	625	mm ²
Layer Time	22	5.12208	s

[0011] As shown in Table 2, an additive manufacturing process using a masking beam former to make an example “solid lifter” structure having approximately 75% areal density would take 4.4 s per layer. Substituting a dynamic lens of the present invention, which directs substantially all of the high-power first light beam to the target, the additive manufacturing process can make the same layer in 3.62 s, an improvement of 20%.

TABLE 2 - Solid Lifter Structure ~75% part areal density

	25 x 25 mm Mask Frame	Variable Lens	
Bound Area	60,000	50,000	mm ²
Cross-Sectional Area	45,000	45,000	mm ²
Fill Factor	75%	90%	mm ²
Bed 500 mm x 1000 mm			
Parts / Build	1	1	
Total Section Area	45,000	45,000	mm ²
Frame Area	625	694.4444	mm ²
Frames Required	96	64.8	
Frame Pixels	1,000,000	1,111,111	@ 25 micron
Cross-Section Mass	8.775	8.775	g
Layer Thickness	25	25	micron
Material	Steel	Steel	
Frame Time	0.025	0.025	s
Power Sweep Time	2	2	s
Max Mat'l Area/Frame	625	625	mm ²
Part Area/Frame	468.75	625	mm ²
Layer Time	4.4	3.62	s

[0012] Numerous applications can be envisioned for a high-power dynamic lens that can form substantially all of a high-power light beam into a desired beam shape. A few such applications are plastic and composite welding, metal welding, conformal cooling for injection molds, conformal cooling for hot stamping molds, metal surface treatment (i.e., polishing, temper, local annealing, laser peening), prototyping, low – medium production volume replacement process for lightweight structural components (i.e., casting; composites). Such a high-power dynamic lens may have applications in many industries including, for example, automotive, aerospace production (brackets, nozzles, pump housings, etc.), military (field repair/service), medical implants, and prototyping.

BRIEF DESCRIPTION OF THE DRAWINGS

[0013] Other advantages of the present invention will be readily appreciated, as the same becomes better understood by reference to the following detailed description when considered in connection with the accompanying drawings wherein:

[0014] Figure 1A is a schematic diagram of a dynamic lens according to the present disclosure;

[0015] Figure 1B is a cut-away view of the schematic diagram of Figure 1A, showing the first light beam at section 1B -1B;

[0016] Figure 1C is a cut-away view of the schematic diagram of Figure 1A, showing a representation of the transformation of the first light beam by the lensing array to form the output beam shape;

[0017] Figure 1D is a cut-away view of the schematic diagram of Figure 1A, showing the third light beam defining the output beam shape at section 1D -1D;

[0018] Figure 1E is a front view of a laser diode array;

[0019] Figure 2A is a cut-away schematic view of photoactive cells in the lensing array curving a light beam passing therethrough;

[0020] Figure 2B is a cut-away schematic view of photoactive cells in the lensing array curving a light beam passing therethrough;

[0021] Figure 3 is a block diagram of portions of a dynamic lens according to the present disclosure;

[0022] Figure 4 is a schematic view of an arrangement of a photoactive cell;

[0023] Figure 5 is a schematic view of an alternative arrangement of a photoactive cell;

[0024] Figure 6 is diagram of the Azobenzene molecule in two different configurations;

[0025] Figure 7 is a schematic diagram of an adaptive mask of a type known in the prior art;

[0026] Figure 8 is another schematic diagram of an adaptive mask of a type known in the prior art;

[0027] Figure 9 is an example of a phase pattern shown in Damberg et al. "Efficient Freeform Lens Optimization for Computational Caustic Displays." Optics Express 23.8 (pub. 13 Apr 2015);

[0028] Figure 10 is an output beam shape formed by a light beam focused according to the phase pattern of Figure 9, shown in Damberg et al. "Efficient Freeform Lens Optimization for Computational Caustic Displays." Optics Express 23.8 (pub. 13 Apr 2015);

[0029] Figure 11 is a schematic view of a "System for Performing Additive Manufacturing ('AM') Fabrication Process Using a High-Power Diode Array and a Mask," as disclosed in prior art U.S. Patent Application Publication No. 2014/0252687 (September 11, 2014);

[0030] Figure 12 is a schematic view of the system of Figure 11 "showing how a portion of the optical rays from the diode array are reflected by a polarizing mirror during the fabrication process to prevent them from reaching the substrate," as disclosed in prior art U.S. Patent Application Publication No. 2014/0252687 (September 11, 2014);

[0031] Figure 13 is a perspective view of a "hollow wheel" part having approximately 18% areal density;

[0032] Figure 14 is a perspective view of a plurality of "hollow wheel" parts of Figure 13 in a maximized build area of 158 parts in 1 x .5 m;

[0033] Figure 15 is a perspective view of a "solid lifter structure" part having approximately 75% areal density; and

[0034] Figure 16 is an overhead view of a slice of the “solid lifter structure” part of Figure 15.

DESCRIPTION OF THE ENABLING EMBODIMENT

[0035] Referring to the Figures, wherein like numerals indicate corresponding parts throughout the several views, a dynamic lens **20** is generally shown for projecting a plurality of different output beam shapes **22** upon a target **24** is generally shown. The dynamic lens **20** includes a first light source **26** of laser diodes **28** generating a first light beam **30** at a high-power sufficient for additive manufacturing techniques such as selective layer sintering (SLS) and a first wavelength λ_1 in a path **32** toward the target **24**, which may be planar and disposed transverse to the path **32** as shown in Figure 1A. The first light beam **30** may, for example, have a power of approximately 10 kW or greater. The dynamic lens of the present invention could be used with first light beams **30** having a wide range of power, from 100W to greater than 100 kW. The target **24** may also be contoured and some or all of the target **24** may be disposed at an acute or obtuse angle to the path **32** of the first light beam **30**.

[0036] A controller **34** generates a control signal **36** corresponding to an initial pattern **38** and transmits the control signal **36** to a projector **40** which includes a second light source **42** to generate a second light beam **44** with a second wavelength λ_2 , different from the first wavelength λ_1 , and a spatial light modulator **46** (SLM) to form the second light beam **44** to the initial pattern **38** according to the control signal **36**. Many different means may be used to form the initial pattern **38** in the second light beam **44**, including but not limited to SLM devices, LCDs, LEDs, pre-printed transparencies, cathode ray beams, Digital Light Processing (DLP) devices, etc. Additional optical components such as lenses and filters may be included as well.

[0037] As shown in Figures 2A, 2B, a focusing plane 48 including a lensing array 50 of photoactive cells 52 disposed upon a carrier sheet 54 of glass refracts the first light beam 30, with the degree and direction of refraction varying in response to the photoactive cells 52 being stimulated by the second light beam 44 of second wavelength $\lambda 2$. The initial pattern 38 of the second wavelength $\lambda 2$ light from the projector 40 causes the photoactive cells 52 in the lensing array 50 to form a phase pattern 68 which curves and focuses the first light beam 30 passing therethrough to form the output beam shape 22 on the target 24. The output beam shape 22 may be predetermined, such as in additive manufacturing (“AM”) applications where the output beam shape 22 is used to create parts having predetermined shapes like those shown in Figures 13-16. The output beam shape 22 may be dynamically generated, such as in rapid prototyping additive manufacturing or in applications where the output beam shape 22 is used to weld parts which may have differing contours, distances, and/or orientation from the focusing plane 48.

[0038] As shown in Fig. 1E, the first light source 26 may comprise an array of point sources with each of the point sources generating a portion of the first light beam 30. The point sources may be, for example, individual laser diodes 28. The point sources may be individually controlled on/off or varied in intensity according to a projection map to cause each of the point sources to selectively illuminate a corresponding portion of said focusing plane. A microlens 29 may overlies each of the point sources to focus and direct the portion of the first light beam 30 from the corresponding point source.

[0039] In practice, the arrangement of the present disclosure may allow for output beam shapes 22 which are beyond the capacity of the lensing array 50 acting upon a full-frame first light beam 30 directed upon the entire frame of the focusing plane 48. For example, the lensing array 50 may not be able to focus and direct the first light beam 30 from one corner of the lensing array 50 all the way to an opposite corner of the focusing

plane 48. In such a case, portions of a full-frame first light beam 30 that illuminates the entire focusing plane 48, may be directed to portions of the target 24 outside of the desired output beam shape 22 where they may waste energy and where they may cause other detrimental effects such as causing undesired portions of the target 24 to be melted or otherwise adversely affected. According to an aspect of the present disclosure, portions of the first light source 26 may be individually controlled according to a projection map to inhibit point sources which are not able to be formed into the desired output beam shape 22 upon a target 24. The controller 34 may generate a projection map which may vary according to the desired output beam shape 22 and the predetermined capabilities of the lensing array 50 to focus and direct the first light beam 30 into the output beam shape 22 upon the target 24. Individual point sources or groups of point sources within the first light source 26 may then be selectively illuminated according to the projection map, with point sources that are not capable of being focused onto the desired beam shape 22 being left off.

[0040] A beam combiner 64, which may be a dichroic mirror with different reflectivity to different wavelengths λ_1, λ_2 of light, may be disposed between the first light source 26 and the focusing plane 48 and at a deflection angle 66 for directing the second light beam 44 from the projector 40 onto the focusing plane 48 and allowing the first light beam 30 from the first light source 26 to pass through to the focusing plane 48. In other words, the beam combiner 64 combines the first light beam 30 together with the second light beam 44, with the combined light beams 30, 44 then being directed to the focusing plane 48. The deflection angle 66 may be, for example, 45 degrees from the path 32 of the first light beam 30. The deflection angle 66 may vary depending on the relative angle between the first and second light beams 30, 44.

[0041] As shown in Figures 4-6, each of the photoactive cells 52 includes at least one liquid crystal molecule 56 adjacent at least one photoreactive group 58 of Azobenzene

connected by a spacer chain 60 of flexible hydrocarbon to a photoalignment layer 62 of polymer material disposed on the carrier sheet 54. The photoreactive groups 58 of the photoactive cells 52 undergo a reversible change from a first molecular shape 70 to a second molecular shape 72 in response to light energy at the second wavelength λ_2 . Specifically, the photoreactive group 58 being in the first molecular shape 70 causes adjacent ones of the liquid crystal molecules 56 to be in a first orientation 74 and the photoreactive group 58 being in the second molecular shape 72 causes adjacent ones of the liquid crystal molecules 56 have a second orientation 76 different from the first orientation 74. The different orientations 74, 76 of the liquid crystal molecules 56 cause the photoactive cells 52 to assume different indices of refraction having a range or gradient of different values. The photoreactive groups 58 of the photoactive cells 52 may change back to the first molecular shape in response to light energy at the different wavelength than the second wavelength λ_2 , such as visible light. This change-back in molecular shape of the photoreactive groups 58 thereby resets the index of refraction of the respective photoactive cells 52. The projector 40 may provide the light energy at the different wavelength than the second wavelength λ_2 to perform such a resetting function. An additional light source may also be used to perform the resetting function.

[0042] Accordingly, the index of refraction 78 of each photoactive cell 52 varies according to the initial pattern 38 to define the phase pattern 68 in the lensing array 50 for curving and focusing the first light beam 30 to form a third light beam 69 that defines the output beam shape 22 on the target 24. Because the lensing array 50 focuses the first light beam 30 to form the output beam shape 22 instead of masking or filtering a portion of the first light beam 30, as is done in the prior art, substantially all of the first light beam 30 is transmitted to the target 24 in the form of the third light beam 69.

[0043] The subject invention also includes a method of operating a dynamic lens 20 to generate an output beam shape 22. The method includes a first step of generating a first light beam 30 having a first wavelength λ_1 by a first light source 26. A second step of the method is generating a control signal 36 by the controller 34 for the initial pattern 38 corresponding to the desired output beam shape 22. The next step is for the controller 34 to transmit the control signal 36 to the projector 40. A fourth step of the method is for the second light source 42 generating a second light beam 44 having a second wavelength λ_2 different from the first wavelength λ_1 . A fifth step is for a spatial light modulator 46 of the projector 40 to form the second light beam 44 to the initial pattern 38 according to the control signal 36. The next step in the method is for the projector 40 to project the light with the second wavelength λ_2 having the initial pattern 38 as a second light beam 44. The beam combiner 64 performs the seventh step of reflecting the second light beam 44 with the initial pattern 38 onto the lensing array 50. The beam combiner 64 also performs the eighth step of transmitting the first light beam 30 from the first light source 26 onto the lensing array 50. The seventh and eighth steps together comprise a broader step of "combining" the first and second light beams 30, 44. The method includes a ninth step in which the index of refraction 78 each of the photoactive cells 52 of the lensing array 50 is adjusted according to the initial pattern 38 to create the phase pattern 68 in the lensing array 50. The method concludes with the lensing array 50 performing the tenth step of focusing and directing the first light beam 30 according to the phase pattern 68 to form a third light beam 69 defining the output beam shape 22 on the target 24.

[0044] The dynamic lens 20 may be used in conjunction with an adaptive mask, such as the type disclosed in Marshall et al. "Computational Chemistry Modeling and Design of Photoswitchable Alignment Materials for Optically Addressable Liquid Crystal Devices." 142 LLE Review at 151 (2015) and/or U.S. Patent Application Publication No.

2014/0252687. In such a case, the adaptive mask may be used to further resolve output beam shapes **22** upon the target **24**.

[0045] Two or more dynamic lenses **20** may be combined serially to further resolve the output beam shapes **22** upon the target **24**.

[0046] Obviously, many modifications and variations of the present invention are possible in light of the above teachings and may be practiced otherwise than as specifically described while within the scope of the appended claims. These antecedent recitations should be interpreted to cover any combination in which the inventive novelty exercises its utility. The use of the word "said" in the apparatus claims refers to an antecedent that is a positive recitation meant to be included in the coverage of the claims whereas the word "the" precedes a word not meant to be included in the coverage of the claims.

CLAIMS

What is claimed is:

1. A dynamic lens for projecting an output beam shape upon a target, said dynamic lens comprising:
 - a first light source generating a first light beam having a first wavelength,
 - a projector including a second light source generating a second light beam having a second wavelength different from said first wavelength and forming said second light beam to an initial pattern,
 - a focusing plane including a lensing array of photoactive cells for refracting said first light beam in response to stimulation by said second light beam having said second wavelength,
 - said initial pattern of said second wavelength light from said projector causing said lensing array of said photoactive cells to form a phase pattern to curve and focus said first light beam to form the output beam shape on the target.
2. The dynamic lens as set forth in Claim 1 wherein substantially all of said first light beam is transmitted to the target in the form of said third light beam.
3. The dynamic lens as set forth in Claim 1 further including a beam combiner for directing said second light beam from said projector onto said focusing plane and passing said first light beam onto said focusing plane.
4. The dynamic lens as set forth in Claim 1 wherein said first light source comprises a plurality of laser diodes.

5. The dynamic lens as set forth in Claim 1 wherein said first light beam has a high-power of at least about 10 kW.

6. The dynamic lens as set forth in Claim 1 further including a controller generating a control signal corresponding to said initial pattern and configured to transmit said control signal to said projector.

7. The dynamic lens as set forth in Claim 6 wherein said projector includes a spatial light modulator to form said second light beam to said initial pattern according to said control signal.

8. The dynamic lens as set forth in Claim 1 wherein said focusing plane includes a lensing array of photoactive cells disposed upon a carrier sheet and variably refracting said first light beam in response to stimulation by said second light beam having said second wavelength,

wherein each of said photoactive cells includes at least one liquid crystal molecule adjacent at least one photoreactive group connected to a photoalignment layer disposed on said carrier sheet, and

wherein said photoreactive groups of said photoactive cells undergo a reversible change from a first molecular shape to a second molecular shape in response to light energy at said second wavelength.

9. The dynamic lens as set forth in Claim 8 wherein said photoreactive group comprises Azobenzene.

10. The dynamic lens as set forth in Claim 8 wherein said spacer chain comprises flexible hydrocarbon.
11. The dynamic lens as set forth in Claim 8 wherein said photoalignment layer comprises polymer material.
12. The dynamic lens as set forth in Claim 1 wherein said first light source includes an array of point sources with each of said point sources generating a portion of said first light beam.
13. The dynamic lens as set forth in Claim 12 wherein said point sources are individually controlled according to a projection map, and with said projection map causing each of said point sources to selectively illuminate a corresponding portion of said focusing plane.
14. A method of operating a dynamic lens including a first light source, a controller, a projector including a second light source and a spatial light modulator and capable of projecting light with a second wavelength, and a lensing array of photoactive cells having an index of refraction to generate an output beam shape of a first light beam having a first wavelength on a target using a control signal for an initial pattern, said method comprising:
 - generating by the first light source a first light beam having a first wavelength,
 - generating by the second light source a second light beam having a second wavelength different from the first wavelength,
 - projecting by the projector the second light beam having the initial pattern,

combining by the beam combiner the first light beam and the second light beam onto the lensing array,

adjusting each of the photoactive cells of the lensing array according to the initial pattern to create the phase pattern in the lensing array, and

focusing and directing the first light beam by the lensing array according to the phase pattern to form the output beam shape upon the target.

15. The method of operating a dynamic lens as set forth in Claim 14 further including:

generating by the controller the control signal for the initial pattern corresponding to the desired output beam shape, and

transmitting by the controller the control signal to the projector.

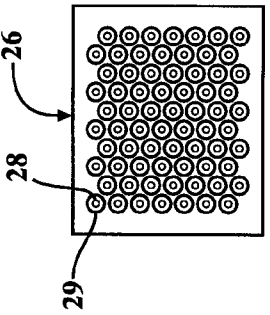
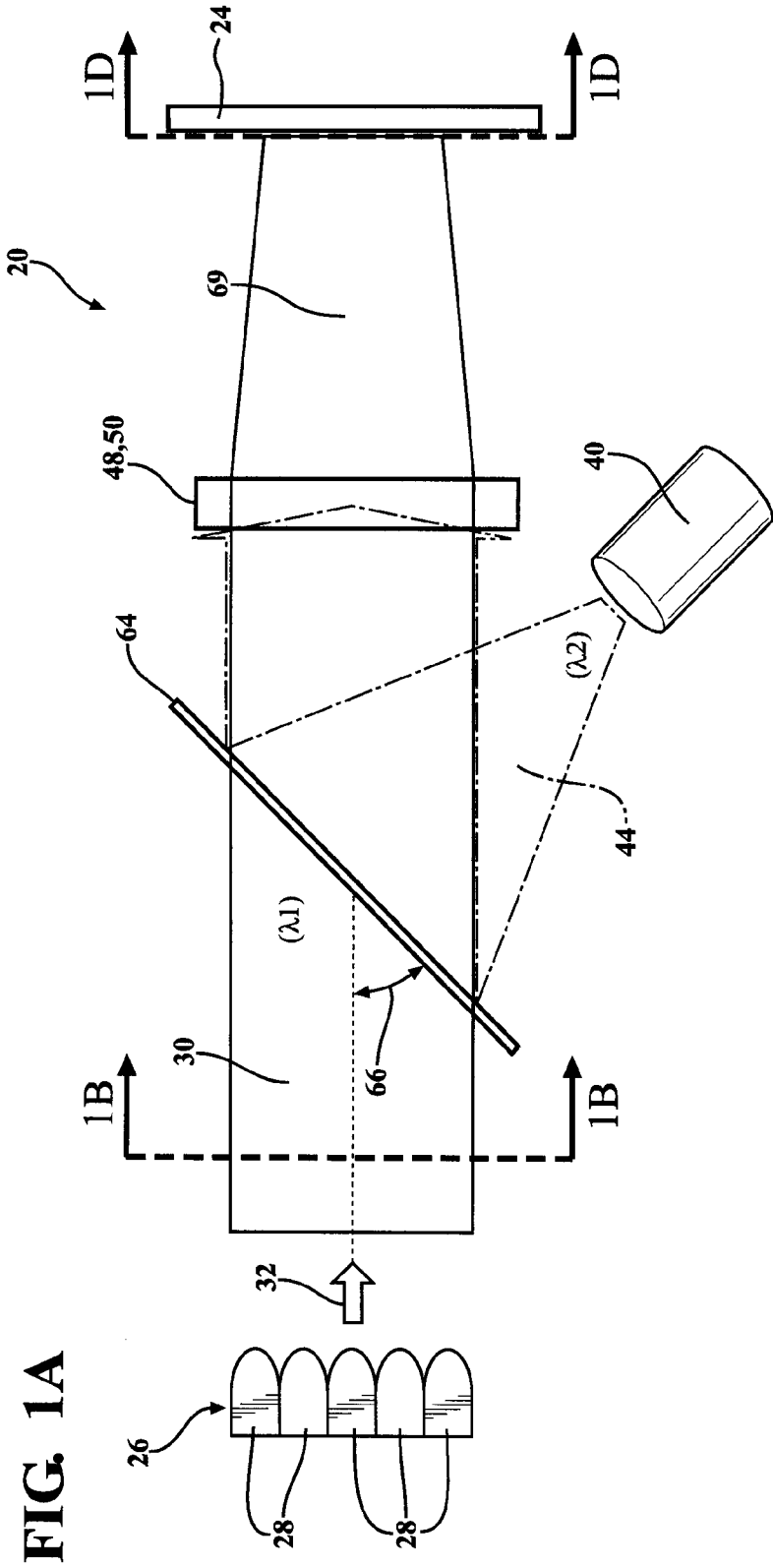

FIG. 1B

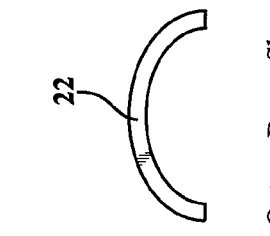

FIG. 1C

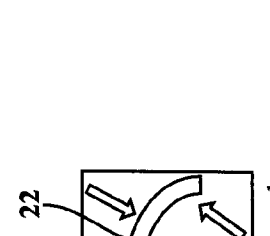

FIG. 1D

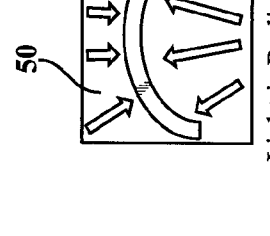

FIG. 1E

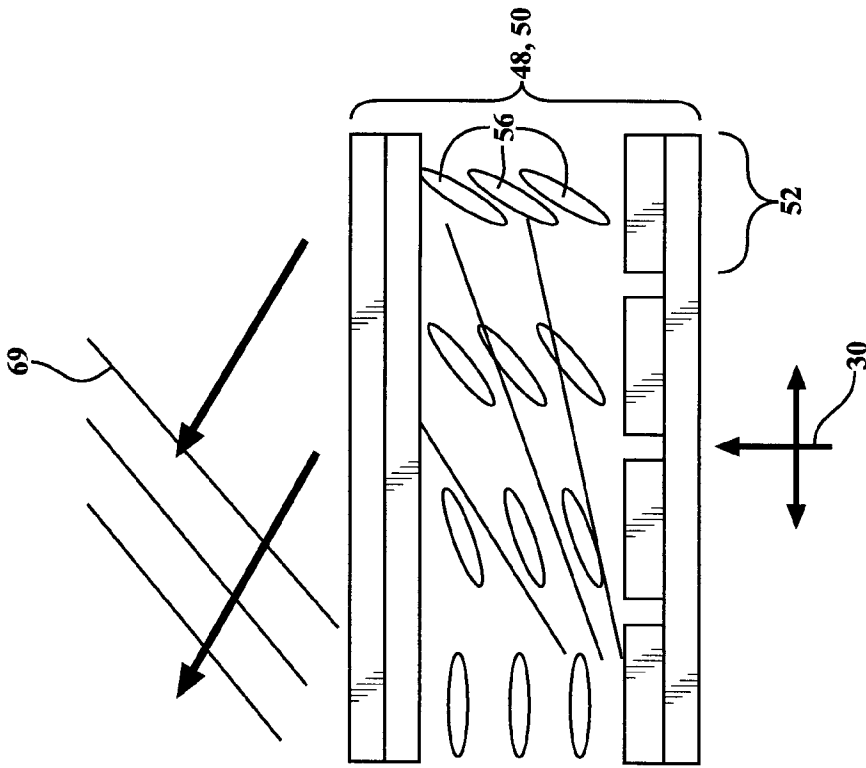

FIG. 2B

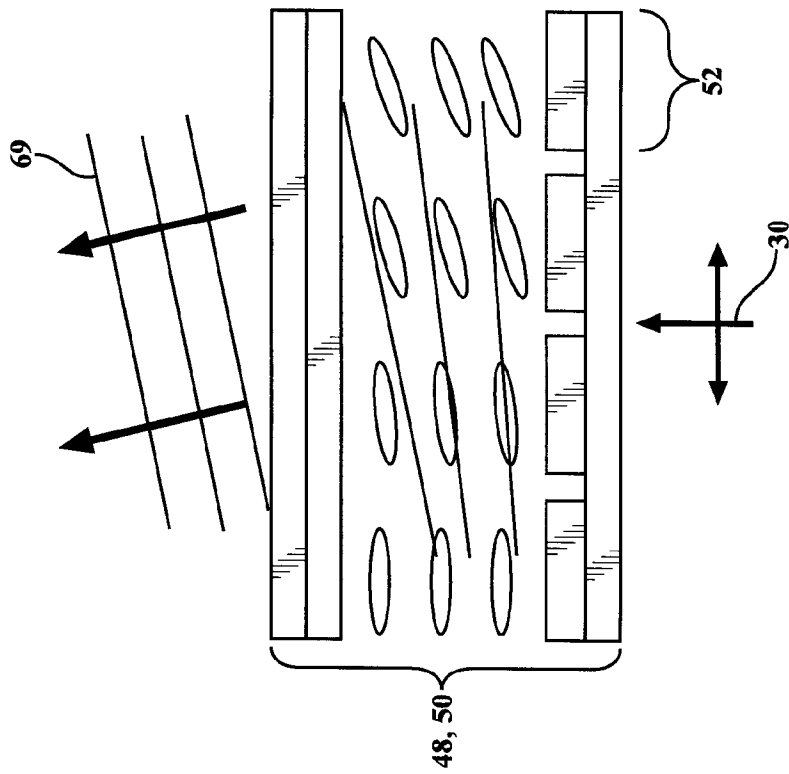

FIG. 2A

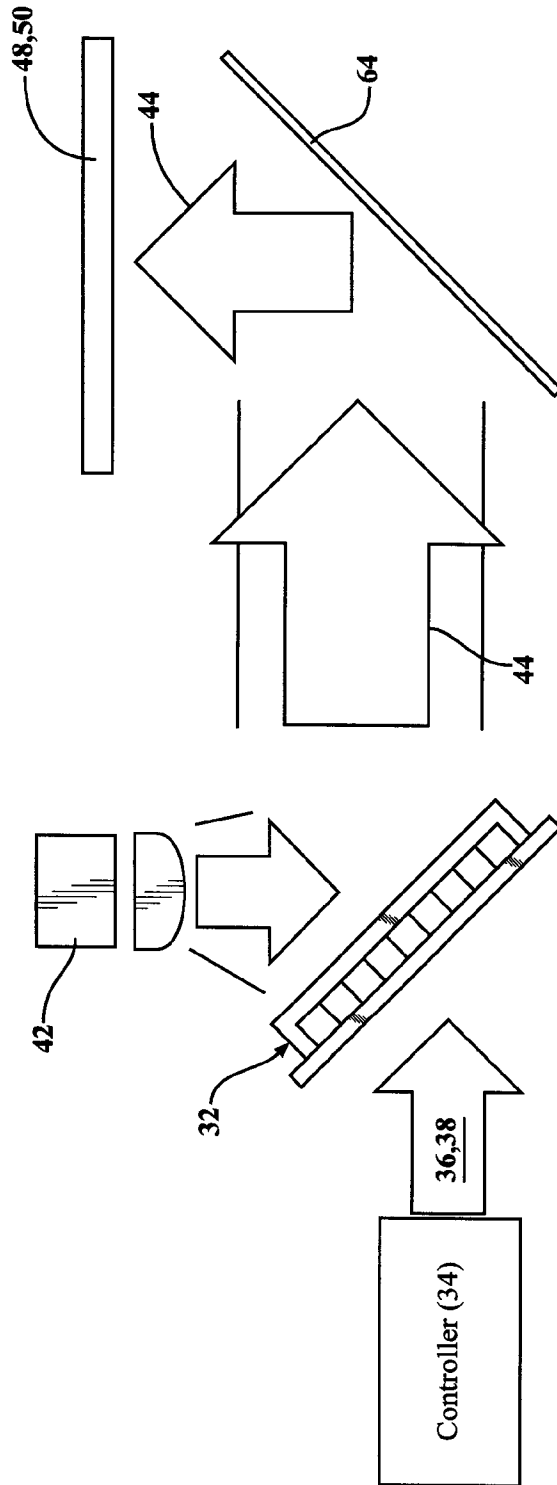

FIG. 3

FIG. 4

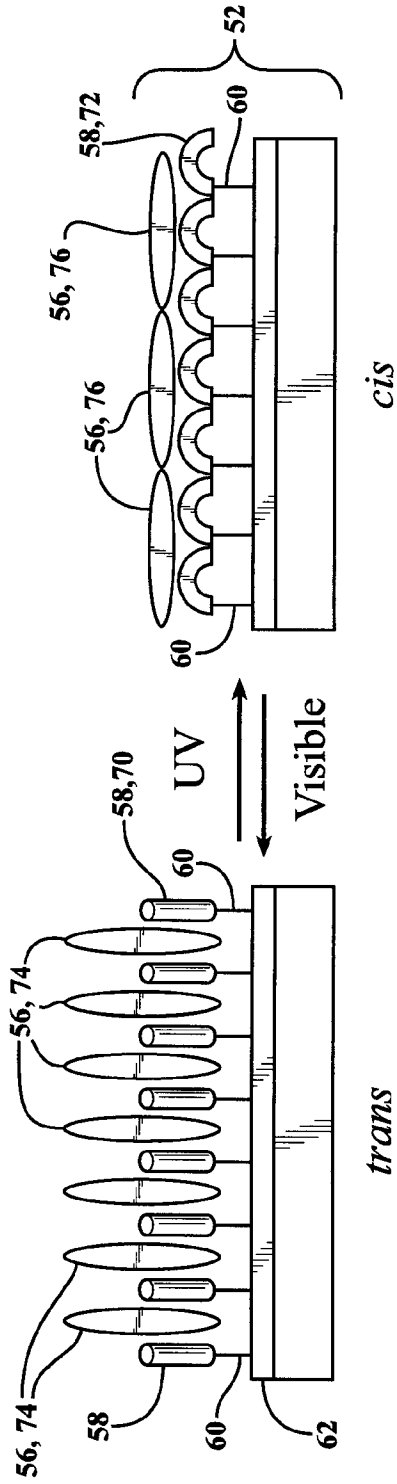
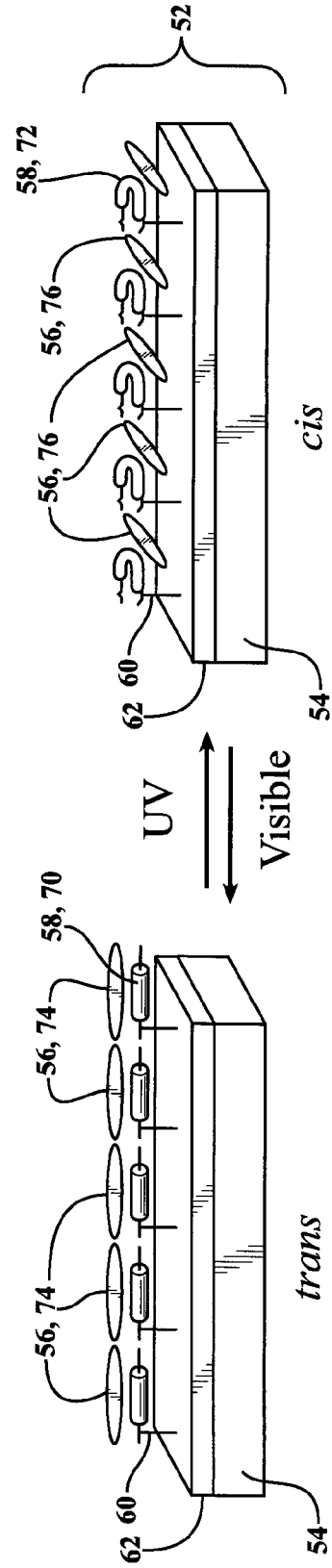

FIG. 5



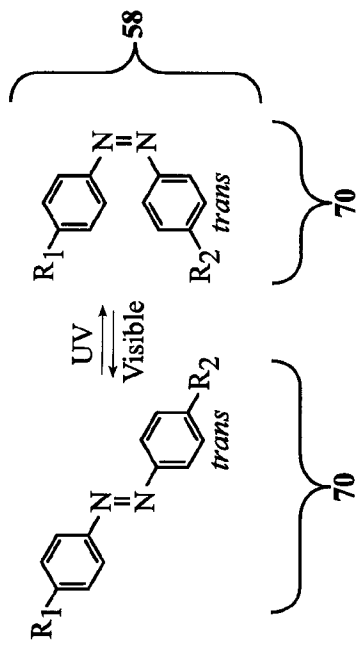

FIG. 6

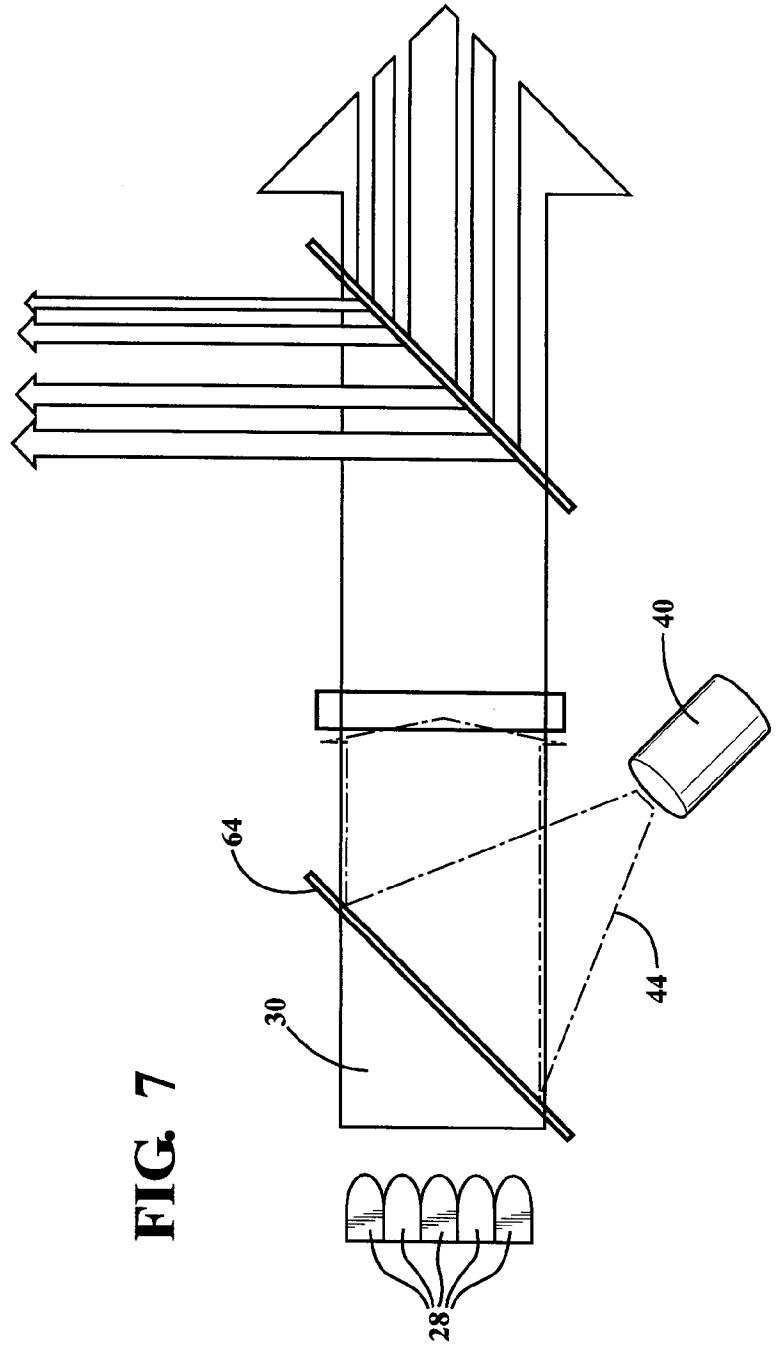

FIG. 7

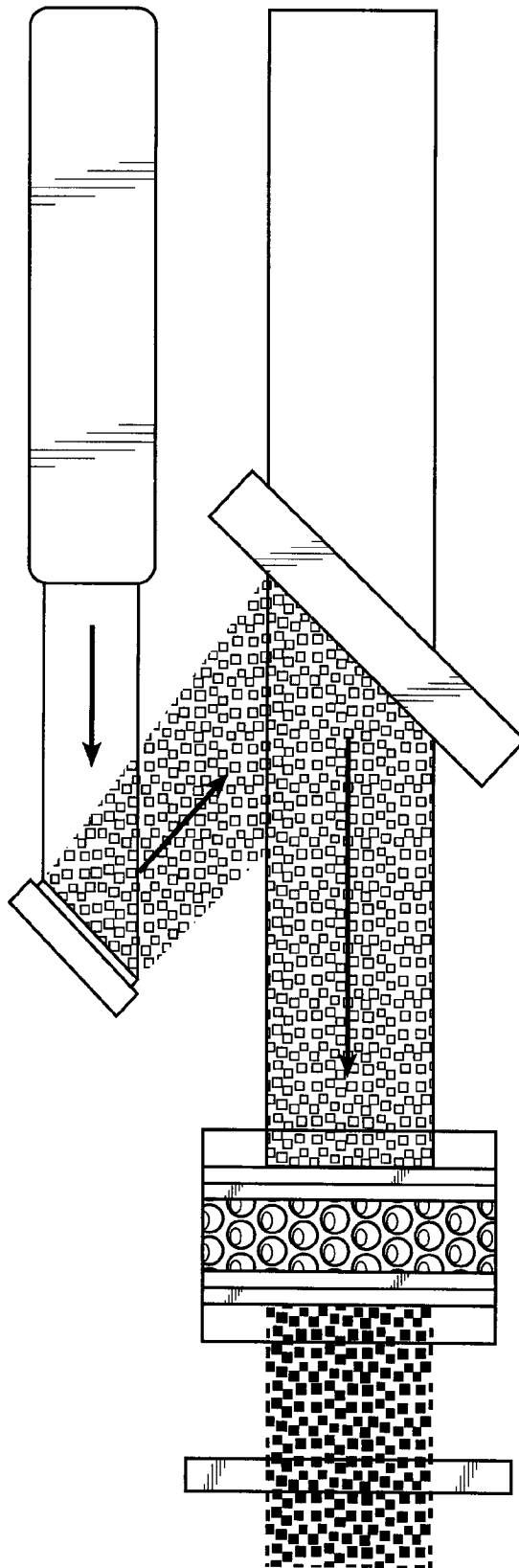

FIG. 8



FIG. 10

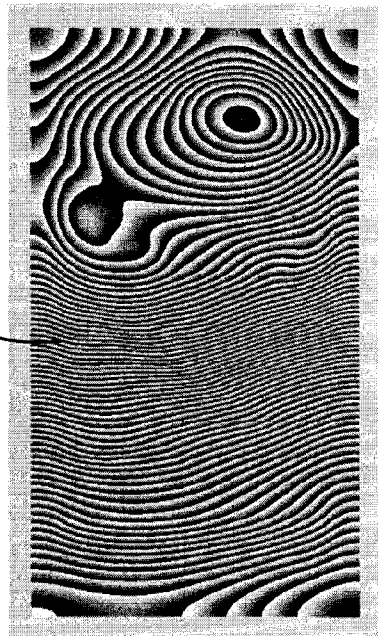

FIG. 9

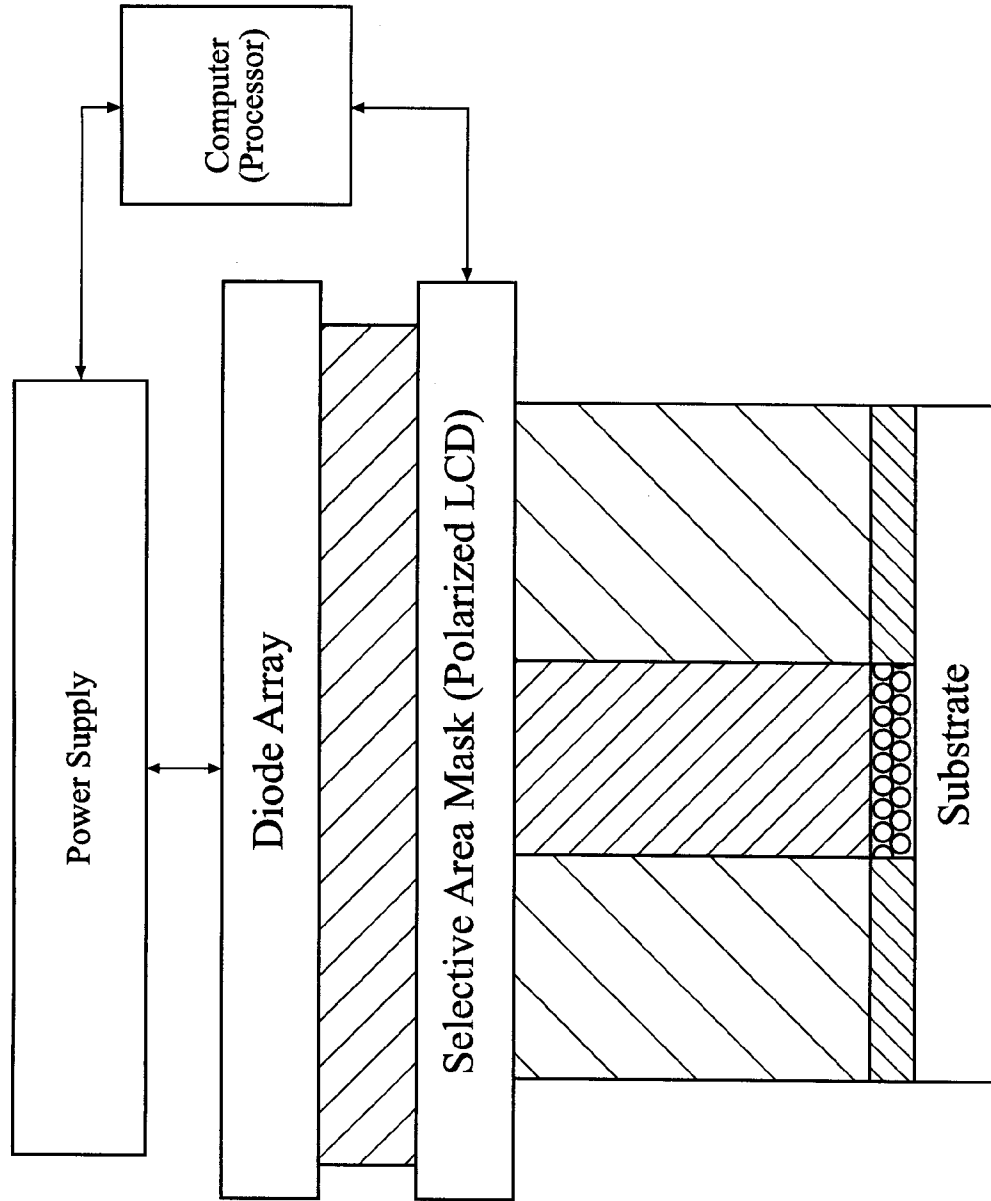

FIG. 11

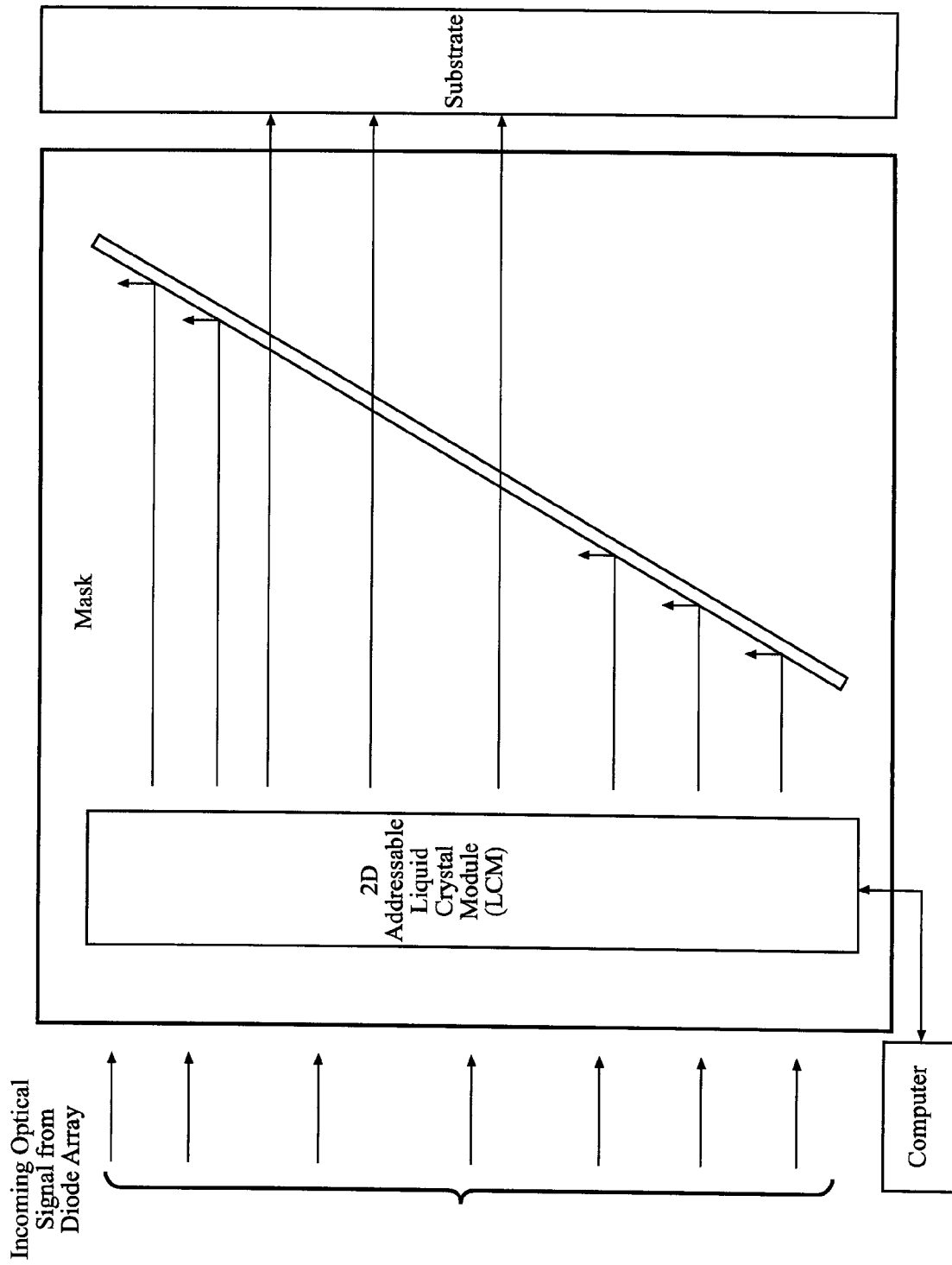

FIG. 12

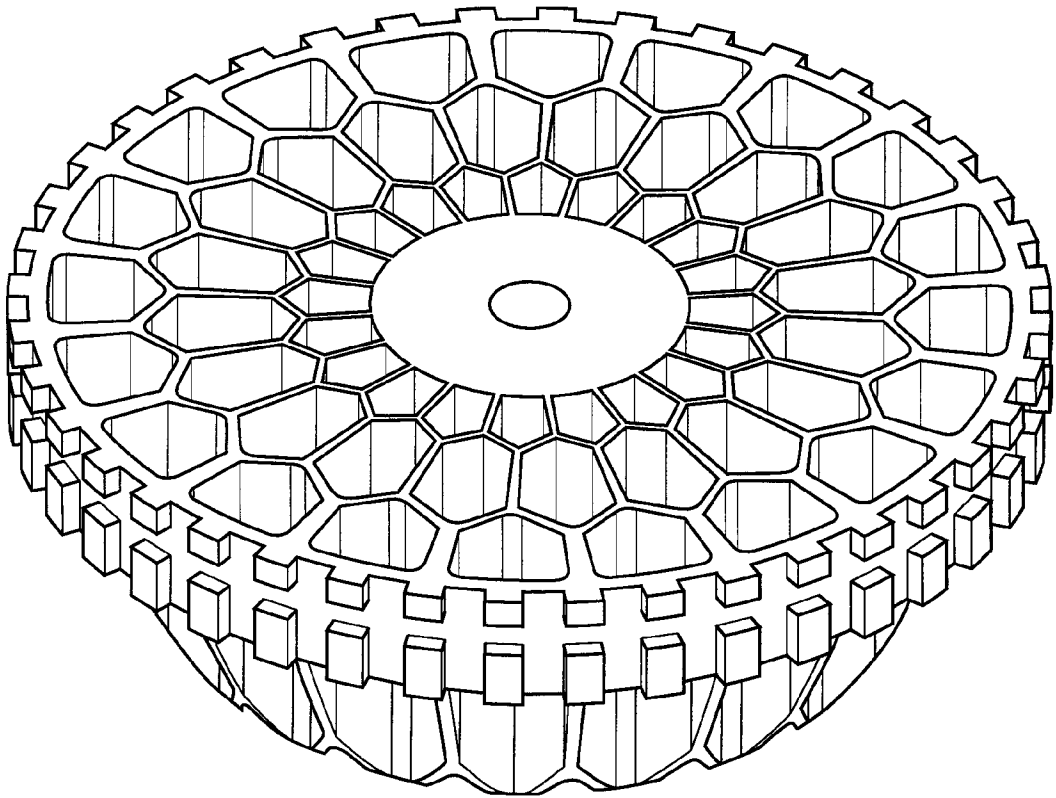

FIG. 13

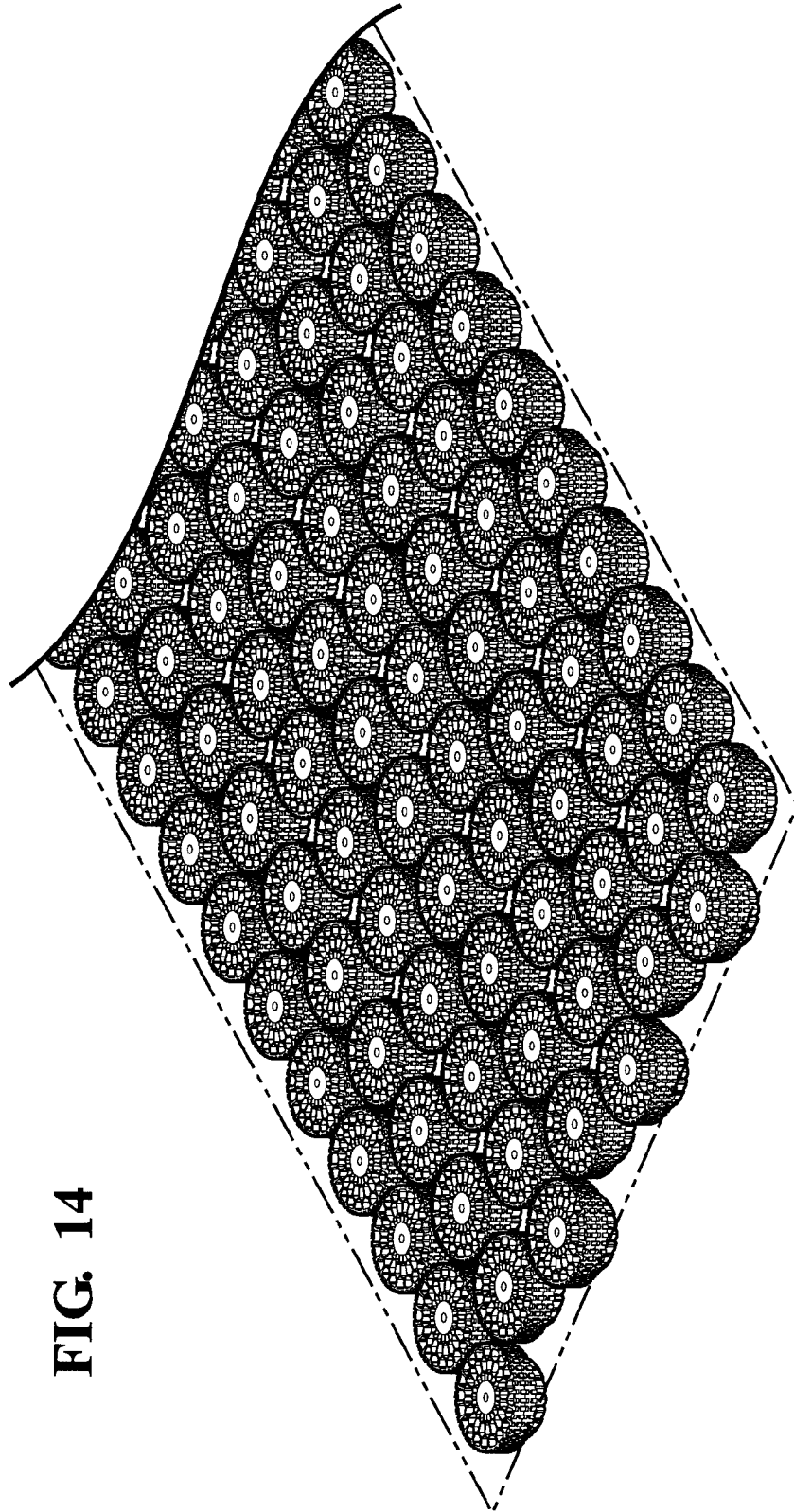

FIG. 14

FIG. 15

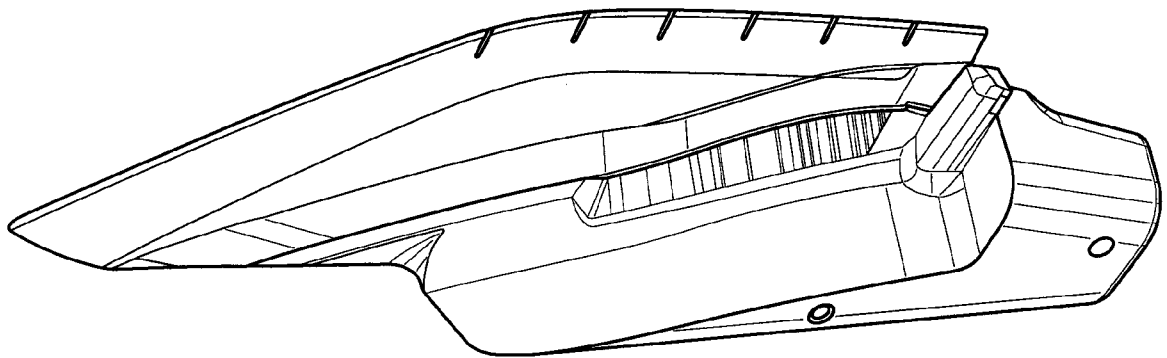
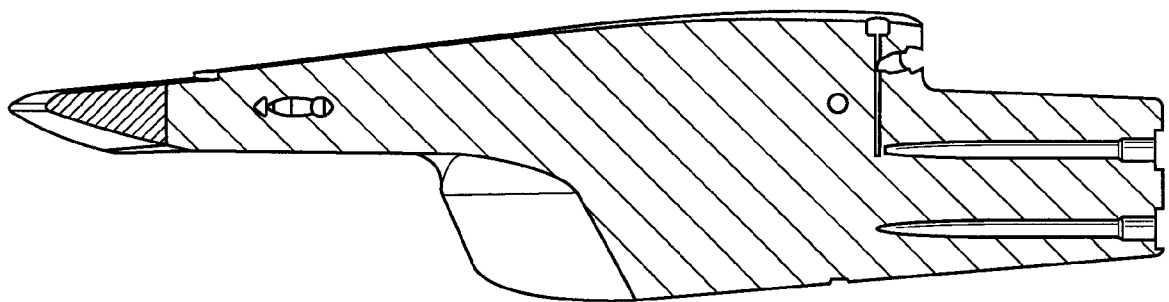

FIG. 16



INTERNATIONAL SEARCH REPORT

International application No.

PCT/CA2017/000086

<p>A. CLASSIFICATION OF SUBJECT MATTER IPC: G02B 27/18 (2006.01), B23K 26/064 (2014.01), B33Y 40/00 (2015.01), G02B 27/09 (2006.01), G02B 27/10 (2006.01), G02B 3/00 (2006.01) (more IPCs on the last page)</p> <p>According to International Patent Classification (IPC) or to both national classification and IPC</p>																																						
<p>B. FIELDS SEARCHED</p> <p>Minimum documentation searched (classification system followed by classification symbols) IPC: G02B 27/18 (2006.01), B23K 26/064 (2014.01), B33Y 40/00 (2015.01), G02B 27/09 (2006.01), G02B 27/10 (2006.01), G02B 3/00 (2006.01) (more IPCs on the last page) (in combination with keywords)</p> <p>Documentation searched other than minimum documentation to the extent that such documents are included in the fields searched</p> <p>Electronic database(s) consulted during the international search (name of database(s) and, where practicable, search terms used) Questel Orbit (keywords dynamic lens, photoactive, pattern, shape, outline, illuminat+, light beam, phase, spatial modulator, EASLM, OASLM, freeform lens)</p>																																						
<p>C. DOCUMENTS CONSIDERED TO BE RELEVANT</p> <table border="1"> <thead> <tr> <th>Category*</th> <th>Citation of document, with indication, where appropriate, of the relevant passages</th> <th>Relevant to claim No.</th> </tr> </thead> <tbody> <tr> <td>Y</td> <td>WO2012172366A1, Cridland et al. 20 December 2012 (20-12-2012) (See page 8, line 10-page 9, line 5)</td> <td>1-15</td> </tr> <tr> <td>Y</td> <td>US6366388B1, Hampp 02 April 2002 (02-04-2002) (See figures 1, 2, 6, column 1, liens 16-43, column 3, lines 11-17)</td> <td>1-15</td> </tr> <tr> <td>A</td> <td>US2014104664A1, Lee et al. 17 April 2014 (17-04-2014) (See whole document)</td> <td>1-15</td> </tr> </tbody> </table> <p><input type="checkbox"/> Further documents are listed in the continuation of Box C. <input checked="" type="checkbox"/> See patent family annex.</p> <table border="1"> <thead> <tr> <th>* "A"</th> <th>Special categories of cited documents: document defining the general state of the art which is not considered to be of particular relevance</th> <th>"T"</th> <th>later document published after the international filing date or priority date and not in conflict with the application but cited to understand the principle or theory underlying the invention</th> </tr> </thead> <tbody> <tr> <td>"E"</td> <td>earlier application or patent but published on or after the international filing date</td> <td>"X"</td> <td>document of particular relevance; the claimed invention cannot be considered novel or cannot be considered to involve an inventive step when the document is taken alone</td> </tr> <tr> <td>"L"</td> <td>document which may throw doubts on priority claim(s) or which is cited to establish the publication date of another citation or other special reason (as specified)</td> <td>"Y"</td> <td>document of particular relevance; the claimed invention cannot be considered to involve an inventive step when the document is combined with one or more other such documents, such combination being obvious to a person skilled in the art</td> </tr> <tr> <td>"O"</td> <td>document referring to an oral disclosure, use, exhibition or other means</td> <td>"&"</td> <td>document member of the same patent family</td> </tr> <tr> <td>"P"</td> <td>document published prior to the international filing date but later than the priority date claimed</td> <td></td> <td></td> </tr> </tbody> </table> <table border="1"> <tr> <td>Date of the actual completion of the international search 18 July 2017 (18-07-2017)</td> <td>Date of mailing of the international search report 08 August 2017 (08-08-2017)</td> </tr> <tr> <td>Name and mailing address of the ISA/CA Canadian Intellectual Property Office Place du Portage I, C114 - 1st Floor, Box PCT 50 Victoria Street Gatineau, Quebec K1A 0C9 Facsimile No.: 819-953-2476</td> <td>Authorized officer David E. Green (819) 635-2861</td> </tr> </table>			Category*	Citation of document, with indication, where appropriate, of the relevant passages	Relevant to claim No.	Y	WO2012172366A1, Cridland et al. 20 December 2012 (20-12-2012) (See page 8, line 10-page 9, line 5)	1-15	Y	US6366388B1, Hampp 02 April 2002 (02-04-2002) (See figures 1, 2, 6, column 1, liens 16-43, column 3, lines 11-17)	1-15	A	US2014104664A1, Lee et al. 17 April 2014 (17-04-2014) (See whole document)	1-15	* "A"	Special categories of cited documents: document defining the general state of the art which is not considered to be of particular relevance	"T"	later document published after the international filing date or priority date and not in conflict with the application but cited to understand the principle or theory underlying the invention	"E"	earlier application or patent but published on or after the international filing date	"X"	document of particular relevance; the claimed invention cannot be considered novel or cannot be considered to involve an inventive step when the document is taken alone	"L"	document which may throw doubts on priority claim(s) or which is cited to establish the publication date of another citation or other special reason (as specified)	"Y"	document of particular relevance; the claimed invention cannot be considered to involve an inventive step when the document is combined with one or more other such documents, such combination being obvious to a person skilled in the art	"O"	document referring to an oral disclosure, use, exhibition or other means	"&"	document member of the same patent family	"P"	document published prior to the international filing date but later than the priority date claimed			Date of the actual completion of the international search 18 July 2017 (18-07-2017)	Date of mailing of the international search report 08 August 2017 (08-08-2017)	Name and mailing address of the ISA/CA Canadian Intellectual Property Office Place du Portage I, C114 - 1st Floor, Box PCT 50 Victoria Street Gatineau, Quebec K1A 0C9 Facsimile No.: 819-953-2476	Authorized officer David E. Green (819) 635-2861
Category*	Citation of document, with indication, where appropriate, of the relevant passages	Relevant to claim No.																																				
Y	WO2012172366A1, Cridland et al. 20 December 2012 (20-12-2012) (See page 8, line 10-page 9, line 5)	1-15																																				
Y	US6366388B1, Hampp 02 April 2002 (02-04-2002) (See figures 1, 2, 6, column 1, liens 16-43, column 3, lines 11-17)	1-15																																				
A	US2014104664A1, Lee et al. 17 April 2014 (17-04-2014) (See whole document)	1-15																																				
* "A"	Special categories of cited documents: document defining the general state of the art which is not considered to be of particular relevance	"T"	later document published after the international filing date or priority date and not in conflict with the application but cited to understand the principle or theory underlying the invention																																			
"E"	earlier application or patent but published on or after the international filing date	"X"	document of particular relevance; the claimed invention cannot be considered novel or cannot be considered to involve an inventive step when the document is taken alone																																			
"L"	document which may throw doubts on priority claim(s) or which is cited to establish the publication date of another citation or other special reason (as specified)	"Y"	document of particular relevance; the claimed invention cannot be considered to involve an inventive step when the document is combined with one or more other such documents, such combination being obvious to a person skilled in the art																																			
"O"	document referring to an oral disclosure, use, exhibition or other means	"&"	document member of the same patent family																																			
"P"	document published prior to the international filing date but later than the priority date claimed																																					
Date of the actual completion of the international search 18 July 2017 (18-07-2017)	Date of mailing of the international search report 08 August 2017 (08-08-2017)																																					
Name and mailing address of the ISA/CA Canadian Intellectual Property Office Place du Portage I, C114 - 1st Floor, Box PCT 50 Victoria Street Gatineau, Quebec K1A 0C9 Facsimile No.: 819-953-2476	Authorized officer David E. Green (819) 635-2861																																					

INTERNATIONAL SEARCH REPORT
Information on patent family members

International application No.
PCT/CA2017/000086

Patent Document Cited in Search Report	Publication Date	Patent Family Member(s)	Publication Date
WO2012172366A1	20 December 2012 (20-12-2012)	WO2012172366A1 GB201110025D0	20 December 2012 (20-12-2012) 27 July 2011 (27-07-2011)
US6366388B1	02 April 2002 (02-04-2002)	US6366388B1 AT262688T DE19831777A1 DE59908965D1 EP1097399A1 EP1097399B1 JP2002520675A JP4562913B2 WO0004415A1	02 April 2002 (02-04-2002) 15 April 2004 (15-04-2004) 03 February 2000 (03-02-2000) 29 April 2004 (29-04-2004) 09 May 2001 (09-05-2001) 24 March 2004 (24-03-2004) 09 July 2002 (09-07-2002) 13 October 2010 (13-10-2010) 27 January 2000 (27-01-2000)
US2014104664A1	17 April 2014 (17-04-2014)	US2014104664A1 US9354604B2 KR20140048735A	17 April 2014 (17-04-2014) 31 May 2016 (31-05-2016) 24 April 2014 (24-04-2014)

G02F 1/133 (2006.01)