

(19) DANMARK

(10)

DK 180102 B1



(12)

PATENTSKRIFT

Patent- og  
Varemærkestyrelsen

- 
- (51) Int.Cl.: **E06B 7/02 (2006.01)** **E04D 13/03 (2006.01)** **F24F 13/18 (2006.01)**
- (21) Ansøgningsnummer: **PA 2017 70587**
- (22) Indleveringsdato: **2017-07-21**
- (24) Løbedag: **2017-07-21**
- (41) Alm. tilgængelig: **2019-01-22**
- (45) Patentets meddelelse bkg. og publiceret den: **2020-05-04**
- (73) Patenthaver:  
**VKR Holding A/S, Breettevej 18, 2970 Hørsholm, Danmark**
- (72) Opfinder:  
**Per Jacobsen, Carl Johansgade 7, 8700 Horsens, Danmark**  
**Borup-Jensen, Rene, Helgenæsgade 8,3. tv., 8000 Århus C, Danmark**
- (74) Fuldmægtig:  
**AWA Denmark A/S, Strandgade 56, 1401 København K, Danmark**
- (54) Titel: **Roof window system with improved transition means between a roof window and a ventilation assembly**
- (56) Fremdragne publikationer:  
**DE 202016100906 U1**  
**EP 2784240 A2**  
**EP 2762653 A1**  
**DE 202012006677 U1**  
**WO 2008/133539 A2**
- (57) Sammendrag:  
**In a roof window system, the roof window (1) has a frame with a frame top member (21), and a sash with a sash top member (31), and further a ventilation device (40) for connection to a ventilation assembly by means of transition means provided between the ventilation assembly and the frame top member (21) and the sash top member (31) of the roof window (1) to accommodate a set of flow paths for air to and from the ventilation assembly. The transition means comprise a plurality of apertures (2102) extending through the frame top member (21).**

Fortsættes...

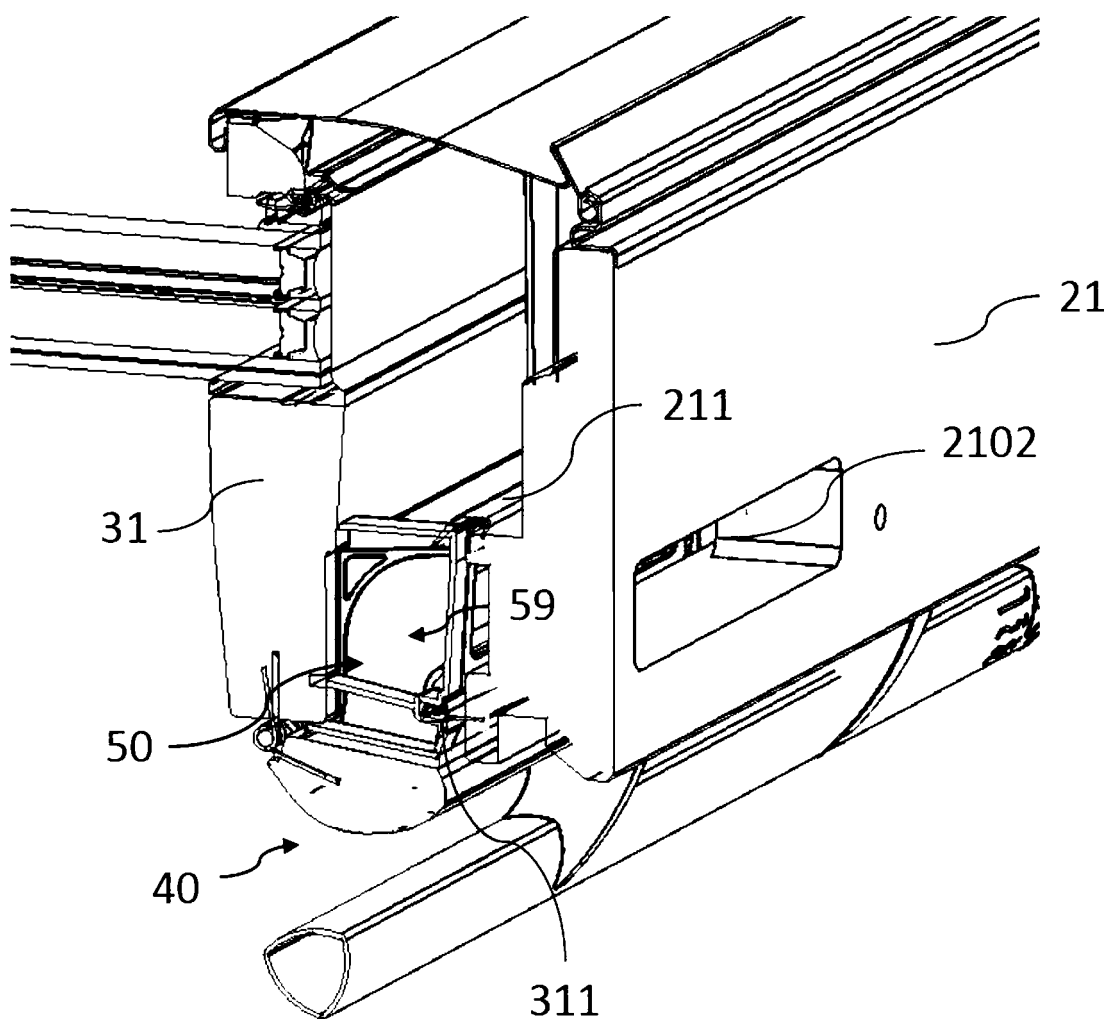

Fig. 18

**Title of Invention**

Roof window system with improved transition means between a roof window and a ventilation assembly.

**5 Technical Field**

The present invention relates to a roof window system comprising a roof window having a frame including a frame top member, two side members and a bottom member, defining a frame plane, and a sash including a sash top member, sash side members and a bottom member, and a pane, the roof  
10 window further comprising a ventilation device adapted for providing ventilation of a building in which the roof window is mounted, a ventilation assembly including a housing accommodating at least one ventilation unit connected to an aperture for air intake and exhaust, transition means being provided between the ventilation assembly and the frame top member and  
15 the sash top member of the roof window to accommodate a set of flow paths for air to and from the ventilation assembly.

**Background Art**

In recent years, the interest in energy-balanced buildings has  
20 increased and several attempts have been made to provide houses in which the energy for heating, cooling, water for domestic use etc. is provided solely by the surroundings.

One area of focus is the windows of the building, since one of the primary functions in a window, besides admitting light, is to allow stale, warm,  
25 or otherwise used or spent air inside the building (so-called "room air") to exit and allowing fresh air from the exterior ("outdoor air") to enter the building in which the window is installed. This presupposes that the window is openable. Over time, the provision of ventilation in windows, also in situations in which the window is not open, either because it is a fixed window, or simply is not  
30 open, has become more or less standard equipment. This is the result of,

among other things, increased focus on improving indoor climatic conditions and the microclimate in buildings. One example of a roof window providing a ventilating aperture is the well-known VELUX® with a ventilation flap, which in pivot-hung windows also fulfils the double function of operating the window.

5           Natural ventilation provided by such a ventilation device has a number of advantages. Among others, it is free of charge and noise-less. However, in certain fields of applications, for instance mechanical ventilation may be desirable. Examples of prior art roof window systems, including roof windows and ventilation assemblies, are shown in for instance Applicant's  
10 European patents EP0458725B1 and EP0372597B1, and in published Danish patent application DK200001472A. Other examples are shown in documents DE102004037563A1, 20204020630U1, DE19811469A1 and DE2906729U1.

          Although many of the above-mentioned prior art roof window  
15 systems, roof windows and ventilation assemblies provide well-functioning solutions, they also require that the roof window is built to receive such a ventilation assembly, typically by designing special parts and/or requiring further investment in the installation of auxiliary parts and installation equipment. Thus, severe limitations as to retro-fitting existing windows exist.

20           One recent development of such roof window systems is described in Applicant's European patent application published under EP 2 784 240 A2. Here, the ventilation assembly takes in outdoor air via ventilation units having flow channels connected to the ventilation device of the roof window and, conversely, allows room air to be led to the exterior in the form of exhaust air  
25 through the ventilation assembly. In one embodiment, the ventilation units comprise a ventilator and a heat exchange device in the form of a regenerator. The counterpart commercial product has proven to work well, and the roof window system alleviates the disadvantages of the earlier prior art to a great extent. One document devising further improvements of the  
30 above EP application is found in DE utility model 20 2016 100 906 U1.

          Although both of these documents devise well-functioning roof

window systems, there is an ongoing aspiration to improve the product itself, with an ever-increasing focus on improving the ventilation properties. Furthermore, challenges as to retrofitting still exist, since the construction of the relevant parts of the roof window depends on the functionality. For instance, a top-hung roof window has a more complex configuration at the top, i.e. at the typical connection point for the ventilation assembly. Similarly, an electrically operated roof window requires space for accommodation of operating equipment at the typical interfaces with the ventilation assembly.

## 10 Summary of Invention

With this background, it is therefore an object of the present invention to provide a roof window system, which provides for an improved connection between the roof window and the ventilation assembly, irrespective of the functionality of the roof window, and which at the same time provides for increased insulation.

This and further objects are achieved with a roof window system of the kind mentioned in the introduction, in which said transition means comprise a plurality of apertures extending through the frame top member

Thereby a roof window system is provided in which the transition between the two components of the roof window system, i.e. the roof window and the ventilation assembly, is carried out at a position which is as neutral as possible, that is, rather than leading the flow paths above the top frame member as in the prior art, the frame may accommodate other equipment as well, for instance a top hinge device. Furthermore, guiding the air through the frame top member also entails improved insulation properties, as the flow paths will extend through an area with better insulation.

In one presently preferred embodiment, the plurality of apertures extending through the frame top member are located mainly in the bottom half part of the height of the frame top member, more preferably in the lower third part of the height of the frame top member.

Further presently preferred embodiments and further advantages will

be apparent from the following detailed description and the appended dependent claims.

### **Brief Description of Drawings**

- 5           The invention will be described in more detail below by means of a non-limiting example of an embodiment and with reference to the schematic drawing, in which
- Fig. 1 shows a roof window system mounted in a roof;
- Fig. 2 shows a perspective view of a roof window system in an  
10   embodiment of the invention;
- Fig. 3 shows a perspective view of the roof window system of Fig. 2, seen from another angle;
- Fig. 4 shows a perspective view of the roof window of the roof window system of Fig. 3, the ventilation assembly being removed;
- 15           Figs 5 to 9 show perspective views of details of the ventilation assembly of the roof window system shown in Fig. 3;
- Fig. 10 shows a detail of the ventilation assembly shown in Fig. 7, on a larger scale;
- Fig. 11 shows a detail of the roof window shown in Fig. 4, on a larger  
20   scale;
- Fig. 12 shows a partial perspective view of the roof window of Fig. 4;
- Fig. 13 is a partial perspective sectional view of the roof window of Fig. 5;
- Fig. 14 is a sectional view of the roof window;
- 25           Fig. 15 shows a perspective view of a detail of the roof window embodiment shown in Fig. 14;
- Fig. 16 shows a perspective view of the detail of Fig. 15, from another angle;
- Fig. 17 is an exploded perspective view of the detail shown in Figs 15  
30   and 16;
- Fig. 18 is a partial perspective sectional view of the roof window of

Fig. 4; and

Fig. 19 is an enlarged fraction showing details of the roof window in an embodiment of the roof window system according to the invention.

## 5 Description of Embodiments

Referring first to Fig. 1 showing the overall appearance and principles underlying a roof window system in an embodiment of the invention, the roof window system comprises a roof window 1 and a ventilation assembly generally designated 100.

10 The roof window 1 comprises at least one frame, in the embodiment shown and described two frames, of which one frame 2 is a stationary frame and an openable sash 3 encasing a pane 4. The frame 2 is, in a manner known per se, substantially rectangular and has a top member 21, and further a bottom member and two side members, not shown in detail. The sash 3 has  
15 a top member 31 and two side members 32, 33, and further a bottom member, not shown in detail. The frame 2 is adapted to be built into a roof structure of virtually any kind, typically comprising a number of rafters and battens, and further non-shown details such as vapour barrier collars etc., below a roofing material.

20 In the embodiment shown, the window is centre-hung in that the sash 3 is connected to the frame 2 by a pivot hinge (not shown) provided between side members of the frame 2 and sash 3, respectively, to be openable by tilting the sash 3 of the window 1 about a pivot hinge axis defined by the pivot hinge. As used in this description, a closed position of the roof window 1  
25 means a position in which the frame plane and the sash plane coincide, that is form an angle of 0 degrees with each other. Similarly, an open position of the roof window 1 as used herein generally means a position in which the sash 3 is tilted about the pivot hinge axis such that the frame plane and the sash plane no longer coincide. Notwithstanding the centre-hung roof window  
30 described, the window according to the invention may in other embodiments be top-hung, with or without an intermediate frame structure, have the hinge

axis somewhere between the top and the centre, be side-hung or for that matter even be bottom-hung, or fixed, i.e. not openable. As will be described in further detail below, the roof window system also provides for optional ventilation in the closed position of the window. Furthermore, the window may  
5 be electrically operated, or prepared for retrofitting of an electrical operator. Finally, the roof window system comprises a screening arrangement 5 in the form of a roller shutter

The sash 3 and frame 2 of the window according to the invention may be made of wooden members or members made of cast or extruded  
10 polyurethane (PUR). In the installed position, the frame 2 and sash 3 are protected, in a manner known per se, by an assembly of cover elements generally designated 6 and including a cladding and a flashing arrangement. Towards the interior, a suitable finishing may be provided, for instance comprising a lining panel. In the embodiment shown, the interior side of the  
15 sash members are substantially flush with the interior side of the frame members. Furthermore, the frame bottom member (not shown in detail) may be provided with an over-height, that is, taller than is necessary in order to surround the sash 3, which in turn makes it possible to utilise standard flashing members at the bottom, even if the roof window 1 is installed at a  
20 deep position in the roof structure.

Referring now also to Figs 13 and 14, the roof window 1 has a ventilation device, which in the embodiment shown comprises a ventilation flap 40, which is connected to the top member of the sash 3 via a hinge connection 41 and which furthermore comprises a handle 42.

25 Operating the handle 42 rotates the ventilation flap 40 from an open position to a closed position and vice versa. One or more intermediate positions, in which the ventilation flap 40 may be temporarily locked, may be defined between the open and closed position. In the embodiment shown and described, the sash 3 is pivotally connected to the frame 2, and the ventilation  
30 flap 40 is adapted to assume three position, viz. a first or closed position, in which the roof window 1 is closed and no ventilation is provided, a second

and ventilating position, in which the roof window 1 is still closed but a ventilation aperture is provided to allow air passage, and a third and entirely open position, in which the sash 3 is able to pivot relative to the frame 2 to open the window. In other windows, for instance a top-hung roof window, the ventilation flap 40 may be able to assume only two position, viz. a closed position and an open, ventilating position, whereas operation of the sash takes place in other ways, for instance by a handle or other operating means located at the bottom member of the sash.

The roof window 1 of the invention forms part of a roof window system, which in addition to the roof window 1 comprises a ventilation assembly generally designated 100. In the embodiment shown, the ventilation assembly 100 is positioned above the top member of the window frame 2 as seen in the inclination of the roof.

Details of one embodiment of the ventilation assembly 100 will now be described in further detail with reference to in particular Figs 5 to 9. For the general operating principles underlying the ventilation assembly, reference is made to the above-mentioned EP 2 784 240 A1. The reference includes also ventilation units with ventilators and regenerators accommodated in the ventilation assembly.

The ventilation assembly 100 comprises a housing 150 and a cover 151. The cover 151 has two apertures 152 for air intake and exhaust, the apertures 152 being provided at mutually opposite sides of the cover 151.

Transition means provided between the ventilation assembly 100 and the top frame member 21 and the sash top member 31 of the roof window 1 according to the invention will now be described in some detail. As in the prior art, these transition means are configured to accommodate a set of flow paths to and from the ventilation assembly 100.

In the embodiment shown, the housing 150 of the ventilation assembly 100 is composed of three main components, namely in the form of a plurality of sections including a bottom section 161, an intermediate section 162 and a top section 163. Each of these sections is made of an insulating

material. The material is preferably easy to manufacture and handle during assembly. It is also advantageous that the material is light-weight. In any event, the material should be able to withstand compressional and tensional forces to a certain extent and furthermore be able to provide the tightness  
5 required in such a ventilation assembly. One example is expanded polypropylene (EPP).

The top section 163 functions as a cover to the bottom section 161, and is configured to accommodate internal parts of the ventilation units, cf. Figs 7 and 8. As is apparent, the bottom section 161 has a depth which  
10 exceeds that of the roof window 1, i.e. the bottom section 161 is located deep in the roof structure which is advantageous from an insulation point of view.

The bottom section 161 is provided with a number of recesses or depressed portions, of which flow channel 1501 is shown in Fig. 9 to represent the set of flow channels present in the housing 150 of the  
15 ventilation assembly 100 to form a fluid connection with the flow paths through the transition means.

At the front, or left-hand end of Figs 5 to 9, the bottom section 161 has an entrance portion 161a, which together with the underside of the intermediate section 162 forms an opening constituting a transition channel  
20 1601 to the roof window 1. As shown, there are three other entrance portions corresponding to entrance portion 161a, which in turn provides for four transition channels 1601, 1602, 1603, 1604. All of these transition channels thus form part of the transition means between the ventilation assembly 100 and the roof window 1 and are here formed integrally in the housing 150 of  
25 the ventilation assembly 100.

In the mounted condition, the transition channels 1601, 1602, 1603, 1604 are in direct connection with apertures 2101, 2102, 2103, 2104 in the frame top member 21 (cf. Fig. 12). The bottom section 161 and the intermediate section 162 abut directly on the outer side of the frame top  
30 member 21 such that a substantially tight transition is achieved for the air flowing between the room in which the roof window is mounted and the

ventilation assembly and vice versa.

Referring now also to Figs 12 to 14, with particular reference to Figs 9 to 11, another feature of the invention will be described, which feature enhances the climate provided by the roof window system even further. Here, the transition means comprise a filter assembly as follows: A filter rail 170 is accommodated in the entrance portion 161a in the bottom section 161 of the housing 150. The filter rail 170 is preferably releasably connected to the housing 150. In the embodiment shown, the releasable connection is carried out in that a flange 171 on the filter rail 170 rests on shoulder portion 161b of bottom section 161. The filter rail 170 is provided with lower guide 172 and upper guide 173, which form a track to receive a filter holder 180 by a leg 181 thereof. The filter holder 182 has an opening 182 through which air flows and a surrounding flange 183 to abut on a ventilation rack 50 accommodated in the top sash member 31 as will be described in the following, and furthermore accommodates a filter element 184. The filter holder 180 and the remaining three filter holders, which may be identical to the filter holder 180, are received in the apertures 2101-2104 of the frame top member 21. For reasons of clearness in the reading of the drawings, the filter holder 180 located in the aperture 2101 is shown without a filter element, whereas the filter element 184 shown in aperture 2102 is shown without its filter holder.

A central feature of the invention emanates from in particular Figs 12 and 13, namely that the transition means between the roof window 1 and the ventilation assembly 100, in the embodiment shown represented by filter holder 180 accommodated in aperture 2101, are located in the bottom part of the frame top member 21. Preferably, the apertures 2101, 2102, 2103, 2104 extending through the frame top member 21 are located mainly in the bottom half part of the height of the frame top member 21, more preferably in the lower third part of the height of the frame top member 21. Additionally, or alternatively, the apertures in the frame top member are located below, in the height direction of the frame top member, internal equipment located at the top of the roof window, such internal equipment selected from the list

comprising at least one of: a top hinge device, electrical operator means, a covering assembly, and a screening arrangement.

With reference to Figs 15 to 17, a further aspect of the present invention will be described in detail. Here, it is shown how the ventilation rack  
5 generally designated 50 comprises a plurality of rack sections. Four rack sections are dedicated to ventilation, i.e. to provide a flow path for air to and from the ventilation assembly 100. This applies to a first rack section 51 with aperture 5101, second rack section 52 with aperture 5202, third rack section 53 with aperture 5303 and fourth rack section 54 with aperture 5404. In the  
10 embodiment shown, there are two rack sections dedicated to ventilation on either side to correspond with, i.e. form a fluid connection with, apertures 2101, 2102, 2103, 2104 in the frame top member 21. Furthermore, said plurality of rack sections here comprise a fifth rack section 55 with an aperture 5505 configured to receive locking means (not shown) and a sixth rack  
15 section 56 with an aperture 5606 configured to accommodate operating means of an electrical operator. Seventh and eighth rack sections 57 and 58 correspond to sixth and fifth rack sections 56 and 55, respectively. In the embodiment shown, the rack sections 51-58 are positioned symmetrically about a central rack section 59, but other configurations are conceivable. At  
20 the ends of the ventilation rack 50, an end rack piece 60, 61 is provided. In the exploded view of Fig. 17 one half of the ventilation rack 50 of Figs 15 and 16 is shown, including two rack bridge pieces 62 and 63. By the modular configuration of the ventilation rack 50 described in the above, a few standardised rack sections may be combined to fit any window size and  
25 functionality. In order to prepare the roof window 1 of the roof window system to retrofitting of accessories such as for instance an electrical operator or a screening arrangement, the set of standardised rack sections may also include sections with blind or knock-out plates to be removed in order to accommodate equipment of such accessories. The ventilation rack 50, and in  
30 the embodiment shown, the rack sections, may be manufactured in any suitable way and from any suitable material, for instance moulding of a plastic

material.

Finally, a further and presently preferred aspect of the invention will be described with particular reference to Figs 14 to 19. In a manner known *per se* the frame top member 21 is provided with a frame gasket 211 (frame top member 21 removed in Fig. 14, frame gasket 211 thus shown in a “loose” connection). Together with other sealing elements along the side and bottom of the roof window 1, this frame gasket 211 forms a first, or exterior, sealing plane. Towards the interior, a sash gasket 311, correspondingly with other sealing elements, forms a second, or interior, sealing plane. In the embodiment shown, the sash gasket 311 is received in a track 504 in the ventilation rack 50. To this end, the respective rack sections are provided with track portions (not shown in detail) to form the coherent, through track 504. A plurality of brush seals 501, 502, 503 are connected to the central rack section 59 and the end rack pieces 62, 63, respectively. Together with the frame gasket 211 and the sash gasket 311, the brush seals 501, 502, 503 form one or more closed chambers at the intersection between the frame 2 and the sash 3, here two closed chambers on either side of the central rack section 59. As a consequence, two flow channels between the roof window 1 and the ventilation assembly 100 pass in each of these closed chambers. The presence of such closed chambers are advantageous from a flow and insulation point of view.

It should be noted that the above description of preferred embodiments serves only as an example, and that a person skilled in the art will know that numerous variations are possible without deviating from the scope of the claims.

**List of Reference Numerals**

1	roof window
2	stationary frame
21	frame top member
211	frame gasket
2101	aperture
2102	aperture
2103	aperture
2104	aperture
3	sash
31	sash top member
311	sash gasket
32	sash side member
4	pane
5	screening arrangement
6	assembly of cladding and covering elements
40	ventilation flap
41	hinge connection
42	handle
50	ventilation rack
501	first brush seal
502	second brush seal
503	third brush seal
504	track
51	first rack section (ventilation)
5101	aperture in rack section
52	second rack section (ventilation)
5202	aperture in rack section
53	third rack section (ventilation)
5303	aperture in rack section
54	fourth rack section (ventilation)
5404	aperture in rack section
55	fifth rack section (lock)
5505	aperture in rack section
56	sixth rack section (electrical operator)
5606	aperture in rack section
57	seventh rack section (electrical operator)
58	eight rack section (lock)
59	central rack section
60	end rack piece
61	end rack piece

62	rack bridge piece
63	rack bridge piece
100	ventilation assembly
150	housing
151	cover
152	apertures for air intake
161	bottom section
161a	entrance portion
161b	shoulder portion
162	intermediate section
163	top section
1501	flow channel
1601	transition channel
1602	transition channel
1603	transition channel
1604	transition channel
170	filter rail
171	flange
172	lower guide
173	upper guide
180	filter holder
181	leg
182	opening
183	flange
184	filter element

## P A T E N T K R A V

1. Ovenlysvinduessystem, som omfatter:

et ovenlysvindue (1), som har en karm (2), der indbefatter et  
5 karmoverelement (21), to sideelementer og et bundelement, som definerer et  
karmplan, og en ramme (3), der indbefatter et rammeoverelement (31),  
rammesideelementer (32) og et bundelement, og en rude (4), hvor  
ovenlysvinduet (1) endvidere omfatter en ventilationsindretning (40) indrettet  
til at tilvejebringe ventilation af en bygning, i hvilken ovenlysvinduet er  
10 monteret,

en ventilationsanordning (100), som indbefatter et hus (150),  
der rummer mindst en ventilationsenhed, som er forbundet med en åbning  
(152) til luftindtag og -udtag, overgangsmidler, som er tilvejebragt mellem  
ventilationsanordningen (100) og karmoverelementet (21) og  
15 rammeoverelementet (31) af ovenlysvinduet (1), for at rumme et sæt  
strømningsveje for luft til og fra ventilationsanordningen (100),

k e n d e t e g n e t ved, at

overgangsmidlerne omfatter flere åbninger (2101, 2102,  
2103, 2104), der strækker sig gennem karmoverelementet (21).

20

2. Ovenlysvinduessystem ifølge krav 1, hvor de flere åbninger (2101,  
2102, 2103, 2104), som strækker sig gennem karmoverelementet (21), er  
placeret hovedsageligt i den nederste halvdel af højden af karmoverelementet  
(21), mere fortrinsvis i den nedre tredjedel af højden af karmoverelementet  
25 (21).

3. Ovenlysvinduessystem ifølge krav 1 eller 2, hvor  
ovenlysvinduessystemet omfatter internt udstyr valgt fra listen, som omfatter  
mindst en af: en overhængselsindretning, elektriske driftsmidler, en  
30 afdækningsindretning og et screeningsarrangement.

4. Ovenlysvinduessystem ifølge et hvilket som helst af de foregående

krav, hvor overgangsmidlerne er dannet ud i et med huset (150) af ventilationsanordningen (100).

5 5. Ovenlysvinduessystem ifølge krav 4, hvor huset omfatter en bundsektion (161) og en mellemliggende sektion (162), og hvor overgangsmidlerne omfatter flere overgangskanaler (1601, 1602, 1603, 1604), som er dannet som en åbning mellem et forsænket indgangsafsnit (161a) af bundsektionen (161) og undersiden af den mellemliggende sektion (162).

10

6. Ovenlysvinduessystem ifølge krav 5, hvor bundsektionen (161) og den mellemliggende sektion (162) af huset (150) er lavet af et isolerende materiale, såsom ekspanderet polypropylen (EPP), hvor huset (150) fortrinsvis også indbefatter en overdel (163) af samme materiale.

15

7. Ovenlysvinduessystem ifølge et hvilket som helst af de foregående krav, hvor overgangsmidlerne omfatter en filteranordning, som indbefatter en filterskinne (170), der er forbundet med huset (150) af ventilationsanordningen (100), som er konfigureret til at modtage en 20 filterholder (180), der er konfigureret til at blive modtaget i de flere åbninger (2101, 2102, 2103, 2104), som strækker sig gennem karmoverelementet (21).

8. Ovenlysvinduessystem ifølge krav 7, hvor filterskinnen (170) er aftageligt forbundet til huset (150) og er forsynet med føringer (172, 173), 25 som danner et spor, der er konfigureret til at modtage et ben (181) af filterholderen (182).

9. Ovenlysvinduessystem ifølge et hvilket som helst af de foregående krav, hvor overgangsmidlerne omfatter et ventilationsstativ (50), der er 30 anbragt i rammeoverelementet (31).

10. Ovenlysvinduessystem ifølge krav 9, hvor ventilationsstativet (50) har en modulkonfiguration, som omfatter et sæt af standardiserede stativsektioner, der indbefatter flere stativsektioner (51, 52, 53, 54), som er beregnet til ventilation og indbefatter respektive åbninger (5101, 5202, 5303, 5 5404), der er konfigureret til at danne en fluidforbindelse med åbningerne (2101, 2102, 2103, 2104) i karmoverelementet (21).

11. Ovenlysvinduessystem ifølge krav 10, hvor sættet af standardiserede stativsektioner indbefatter en endestativsdel (62, 63) og et 10 centralstativsafsnit (59), fortrinsvis også et stativafsnit (55) med en åbning (5505), som er konfigureret til at modtage låsemidler og/eller et stativafsnit (56) med en åbning (5606), der er konfigureret til at rumme driftsmidler til en elektrisk drift af ovenlysvinduessystemet.

12. Ovenlysvinduessystem ifølge et hvilket som helst af kravene 9 til 15 11, hvor ovenlysvinduet (1) omfatter en karpakning (211), som definerer et første tætningsplan, og en rammepakning (311), der definerer et andet tætningsplan, og hvor rammepakningen (311) modtages i et spor (504) i ventilationsstativet (50).

20 13. Ovenlysvinduessystem ifølge krav 12, hvor flere børstetætninger (501, 502, 503) er forbundet til ventilationsstativet (50) for at danne et eller flere lukkede kamre sammen med karpakningen (211) og rammepakningen (311), hvor strømningsvejen af overgangsmidlerne til de flere åbninger (2101, 25 2102, 2103, 2104) strækker sig gennem karmoverelementet (21), som er placeret inden i det ene eller flere lukkede kamre.

14. Ovenlysvinduessystem ifølge krav 11 og 13, hvor en første børstetætning (501) er forbundet med centralstativsafsnittet (59), en anden 30 børstetætning (502) er forbundet til en endestativsdel (62) og en tredje børstetætning (503) er forbundet med en anden endestativsdel (63).

15. Ovenlysvinduessystem ifølge krav 14, hvor overgangsmidlerne omfatter fire åbninger (2101, 2102, 2103, 2104), som strækker sig gennem karmoverelementet (21), og ventilationsstativet (50) indbefatter fire 5 stativsektioner, der er beregnet til ventilation, og hvor to af de respektive åbninger (5101, 5202; 5303, 5404) af de første, anden, tredje og fjerde stativsektioner (51, 52, 53, 54) er placeret i hvert lukket kammer, som er dannet af de respektive børstetætninger (501, 502; 501, 503), karpakningen (211) og rammepakningen (311).

1/9

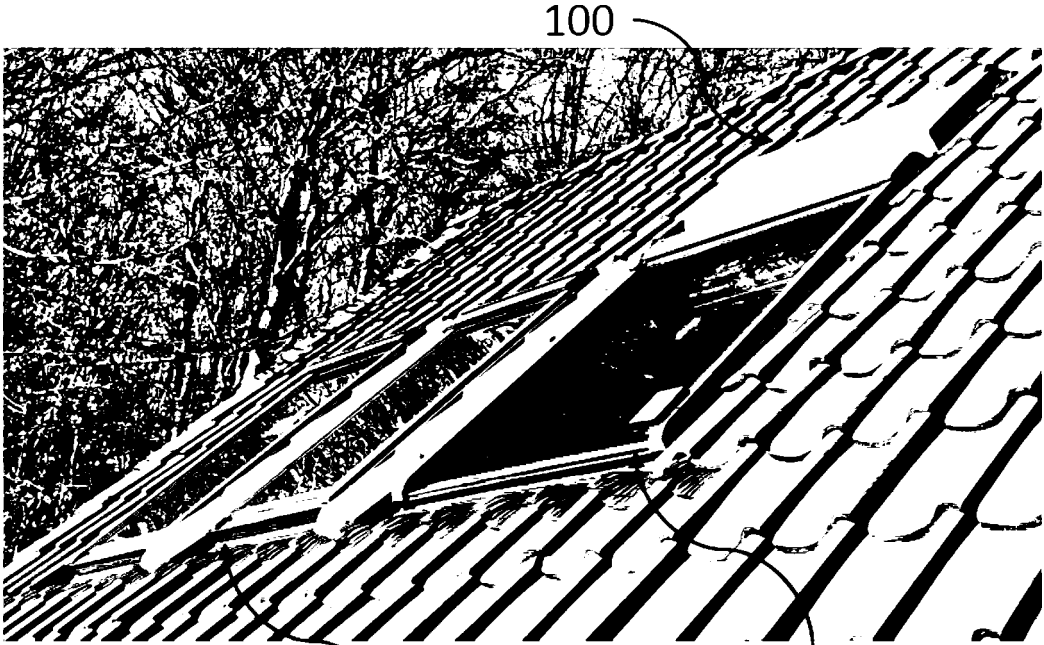

Fig. 1

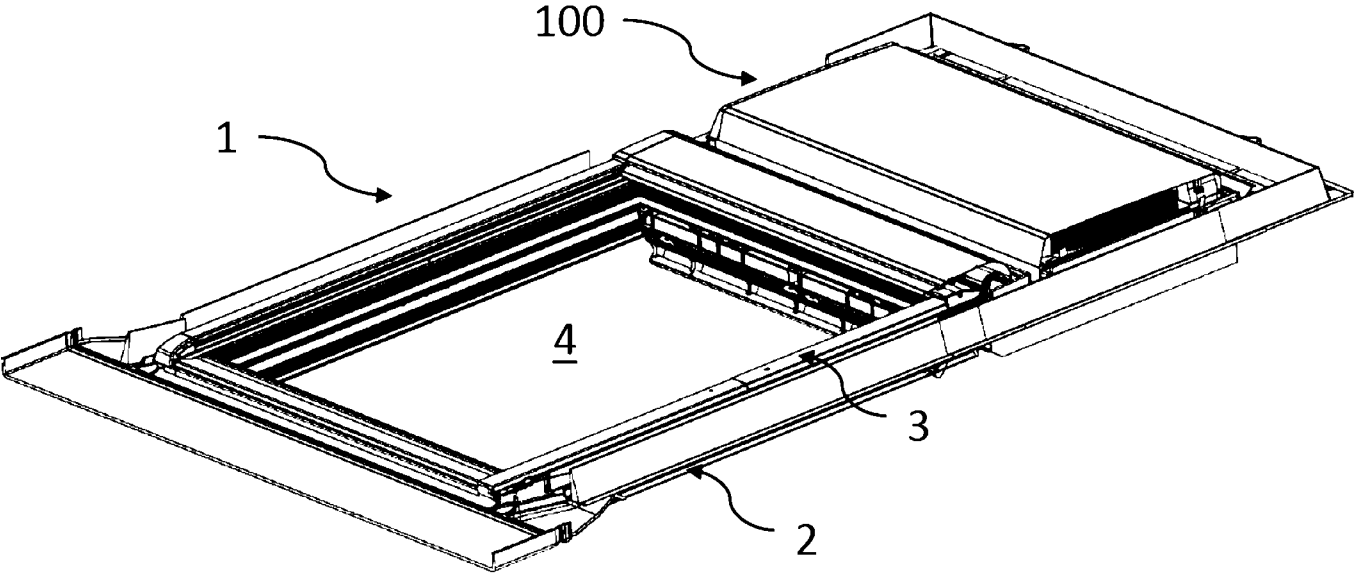

Fig. 2

2/9

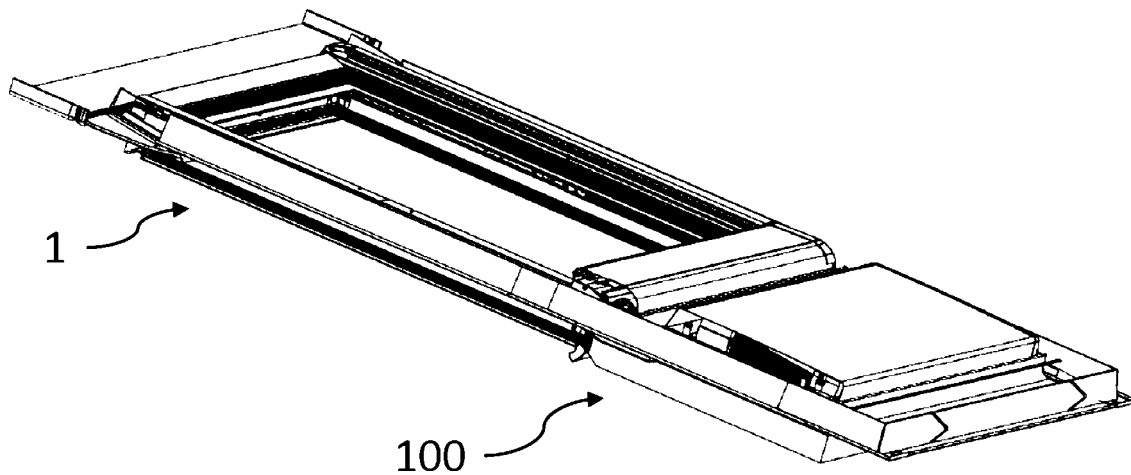

Fig. 3

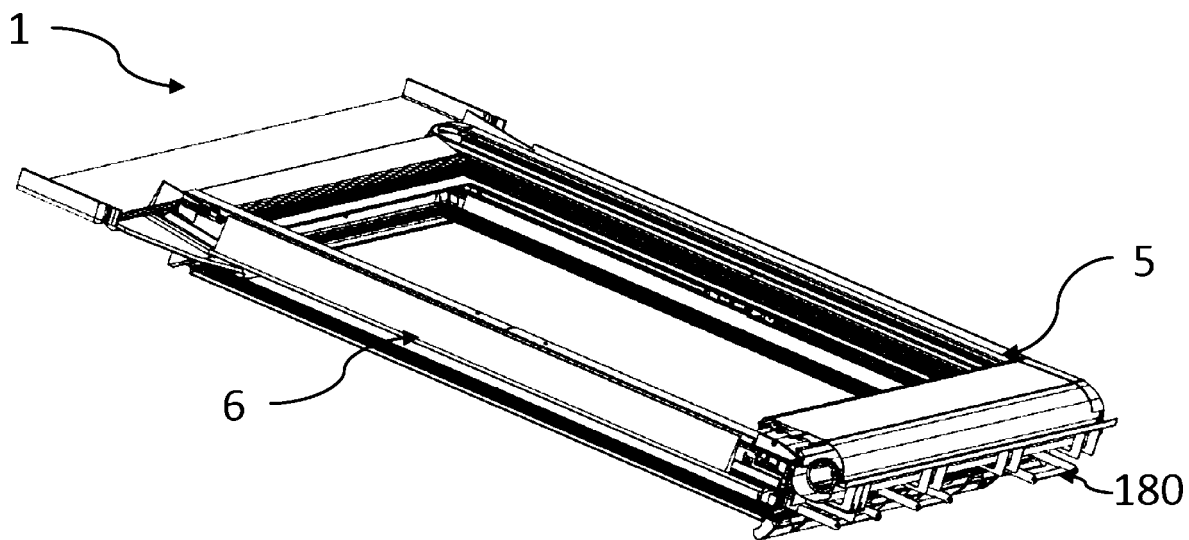

Fig. 4

3/9

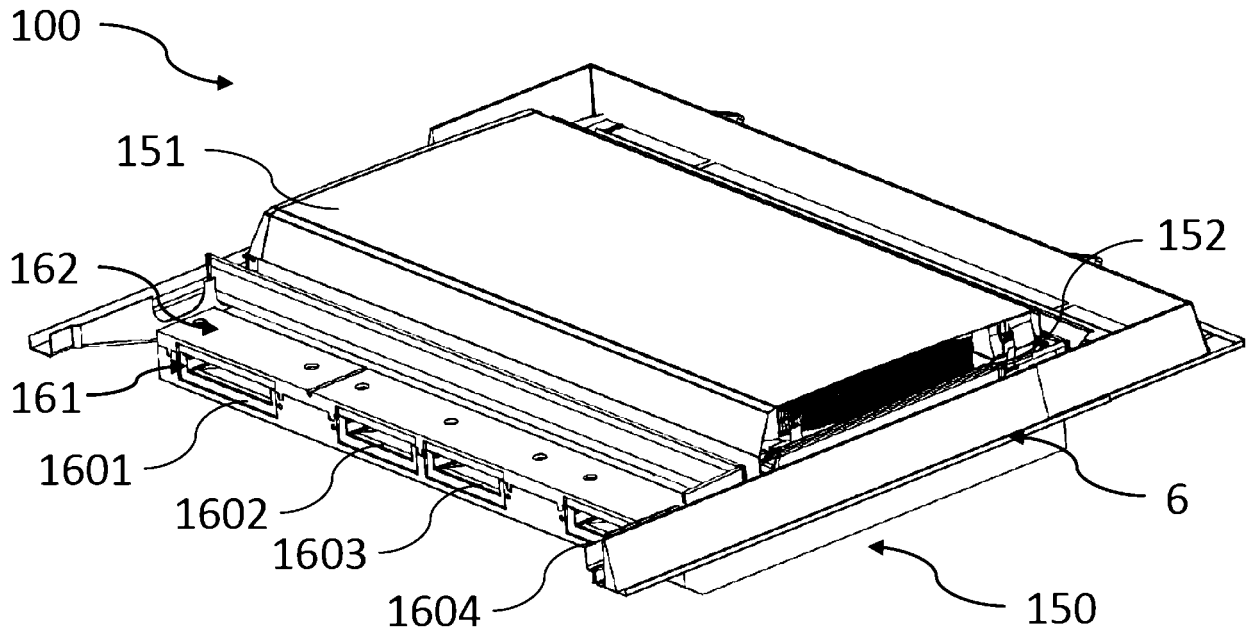

Fig. 5

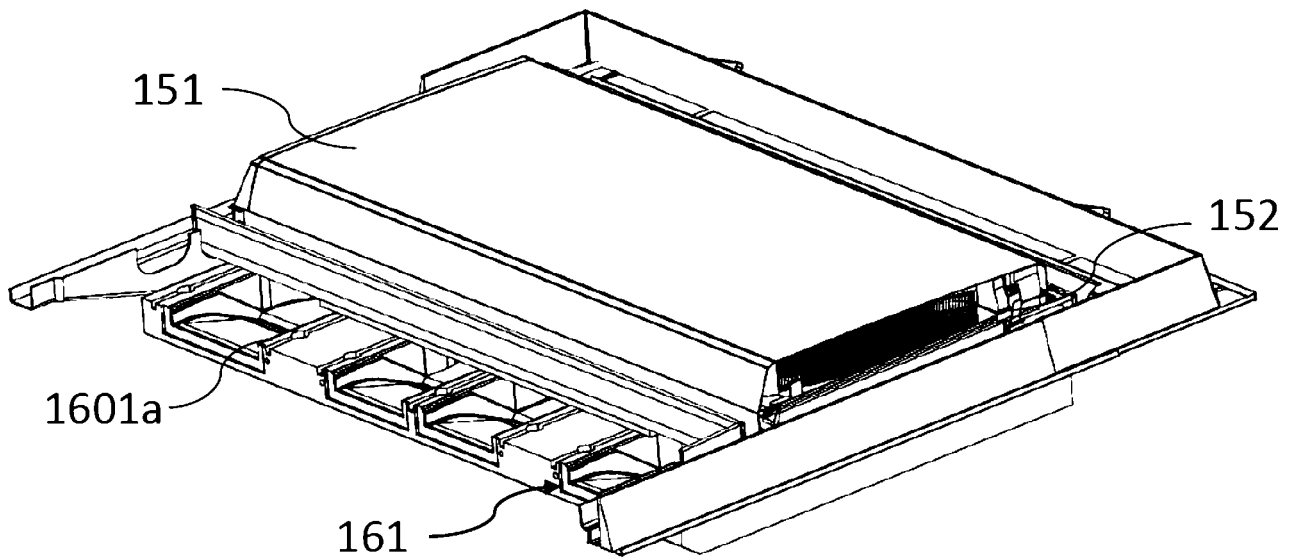

Fig. 6

4/9

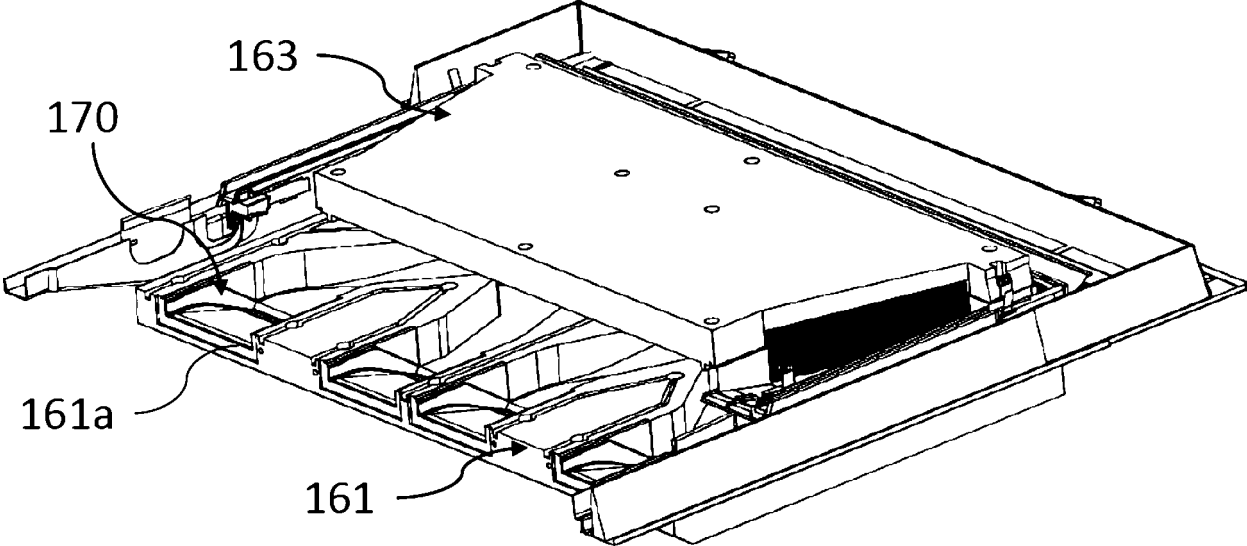

Fig. 7

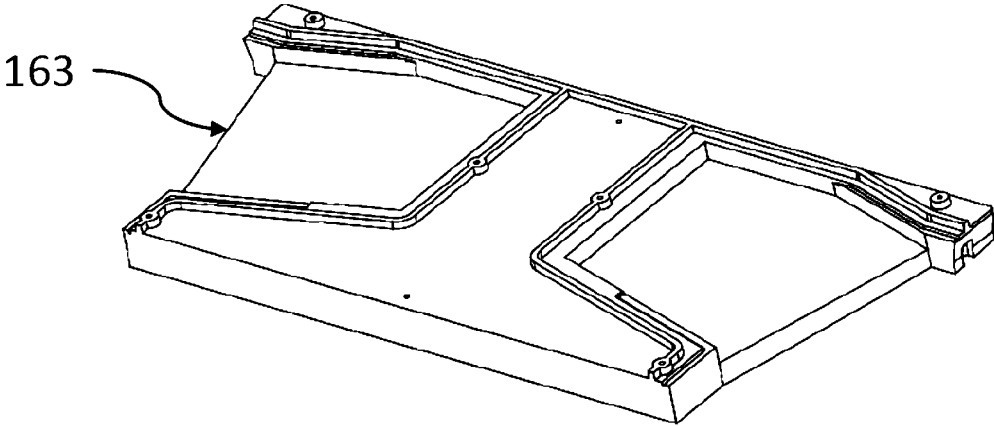

Fig. 8

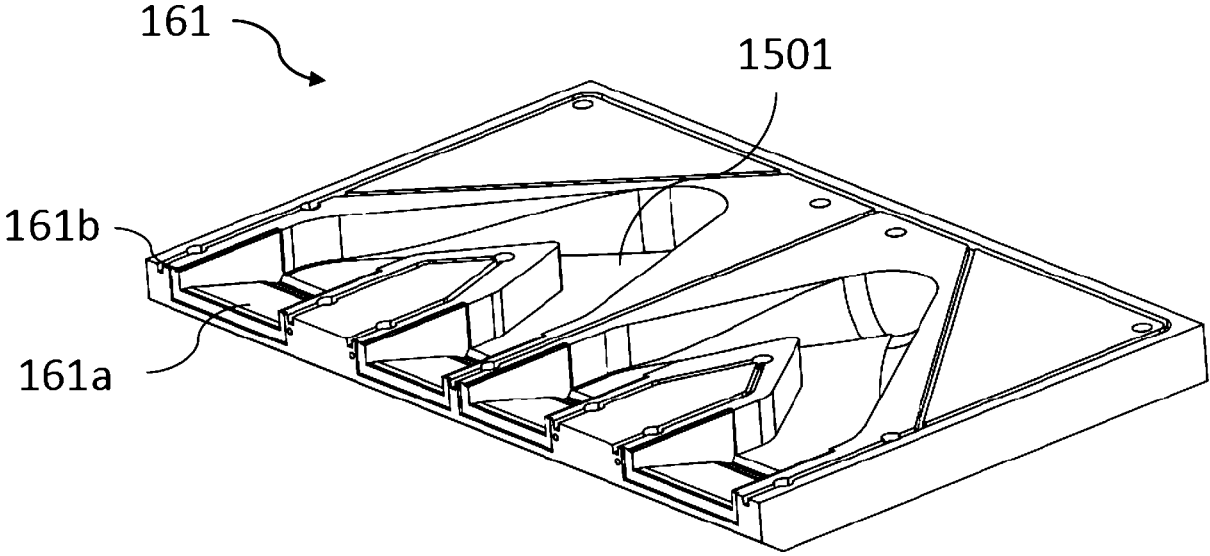

Fig. 9

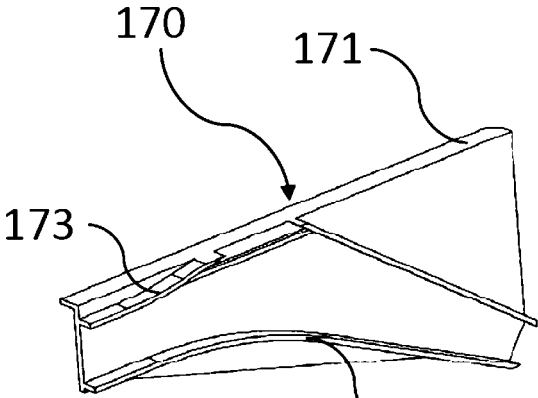

Fig. 10

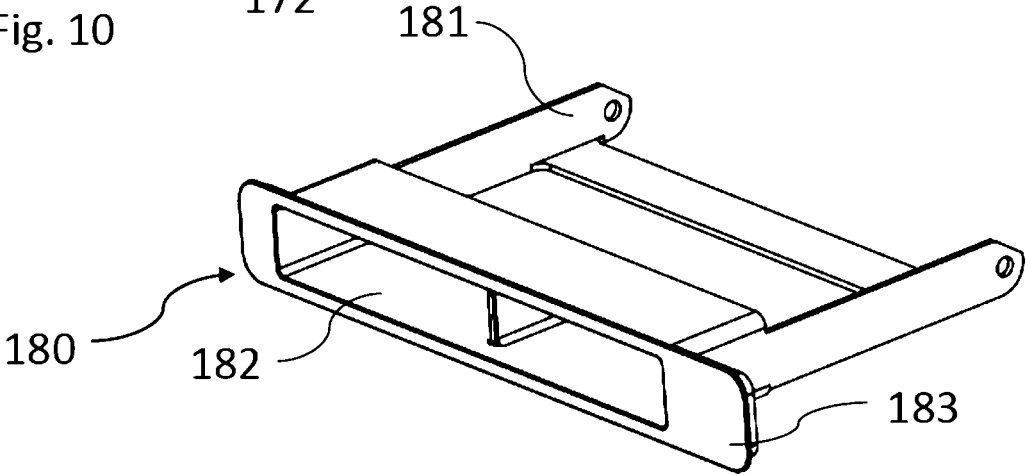

Fig. 11

6/9

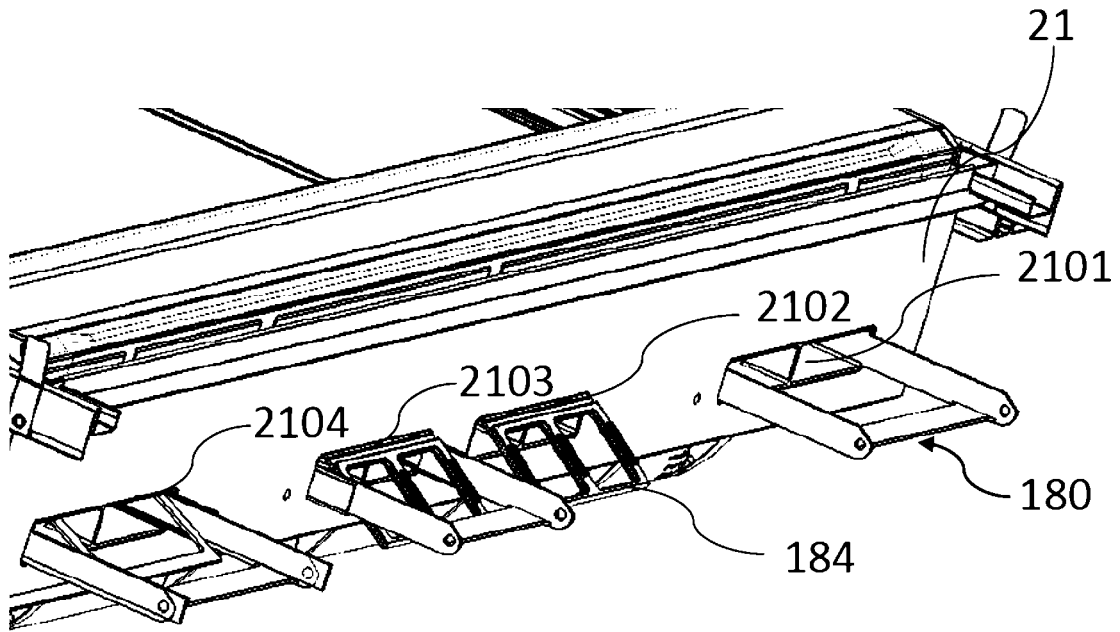

Fig. 12

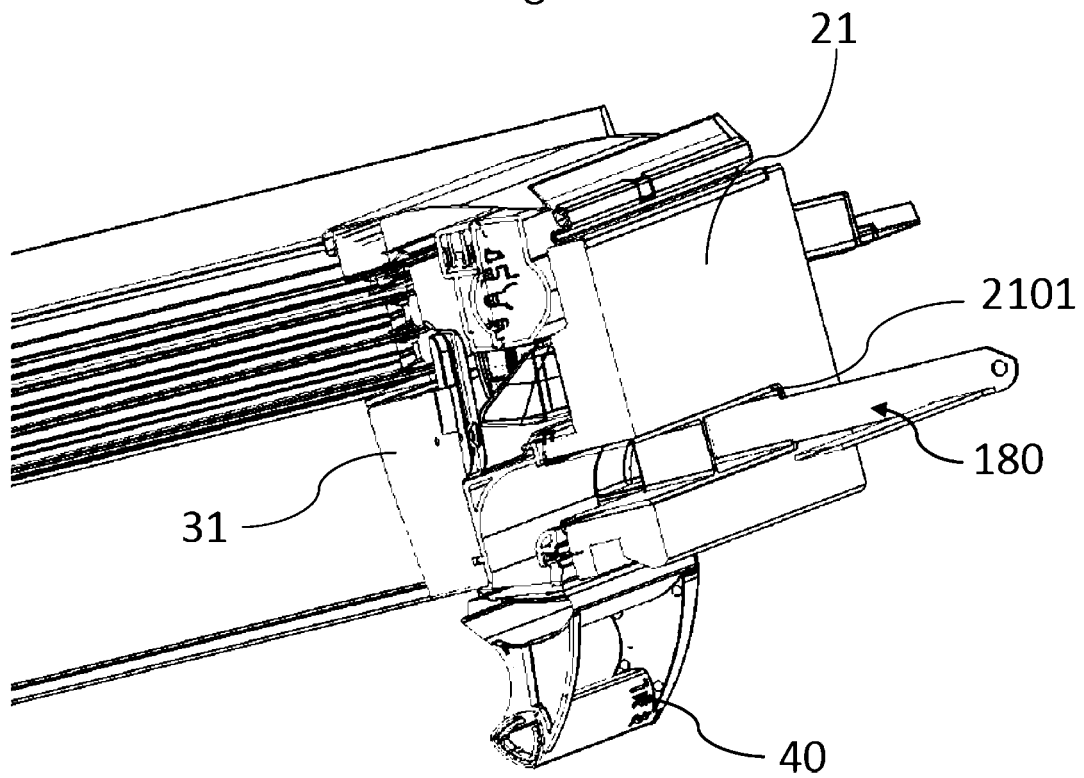

Fig. 13

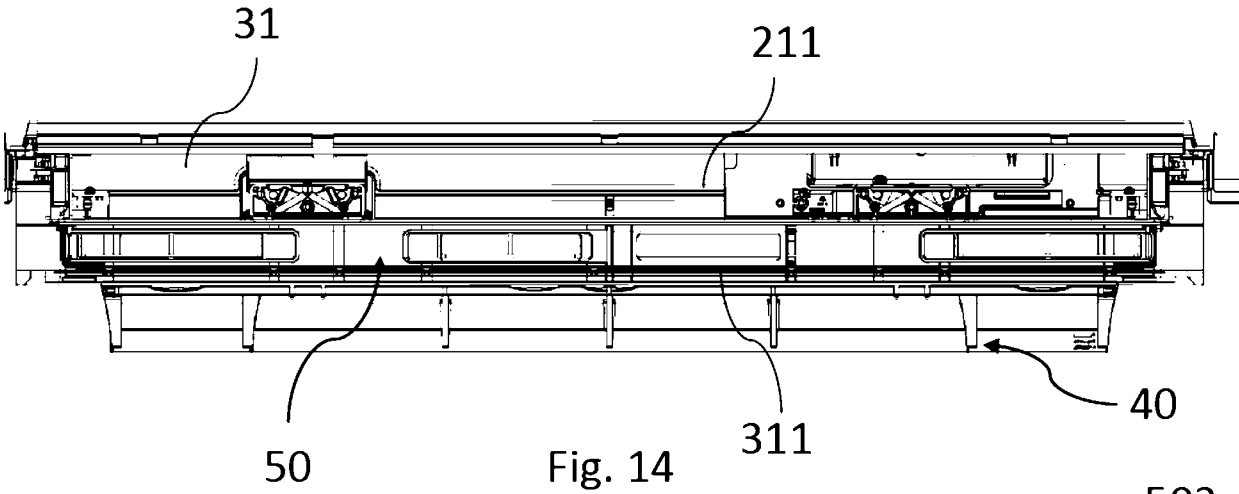

Fig. 14

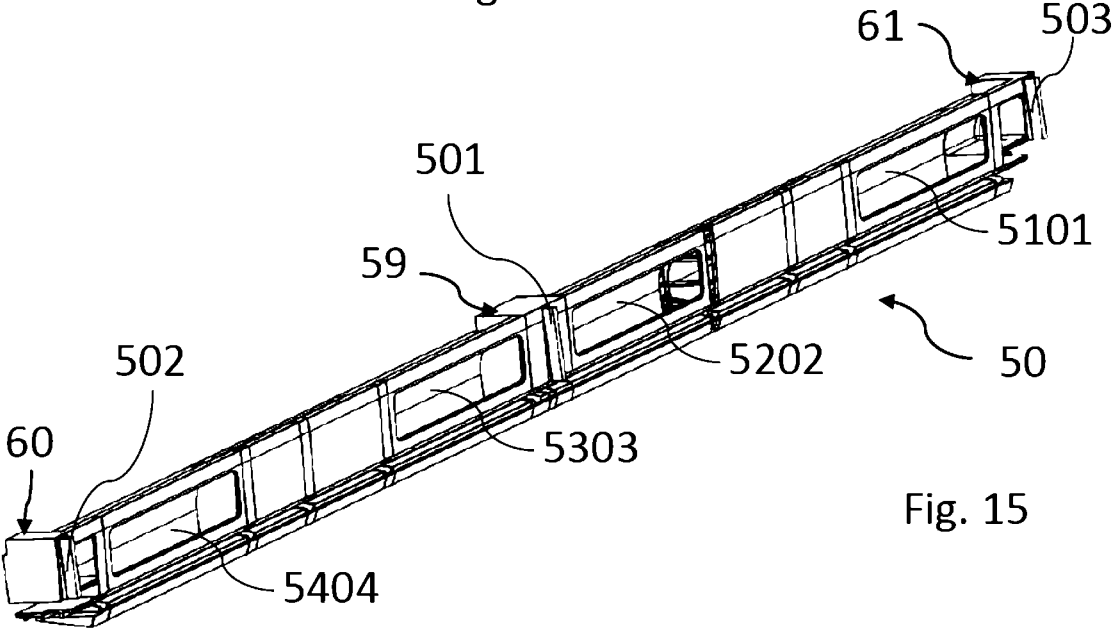

Fig. 15

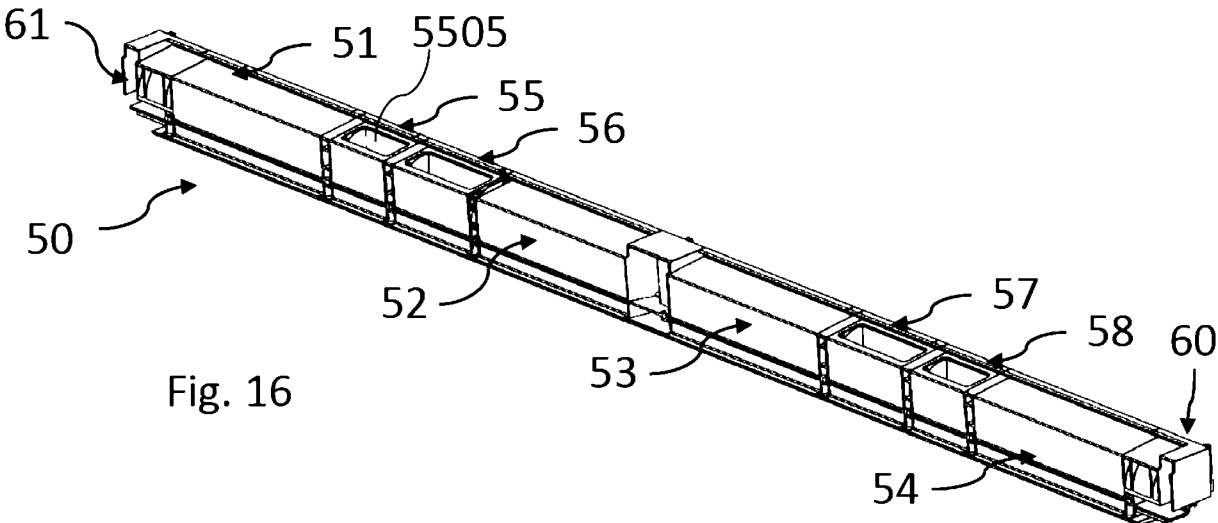

Fig. 16

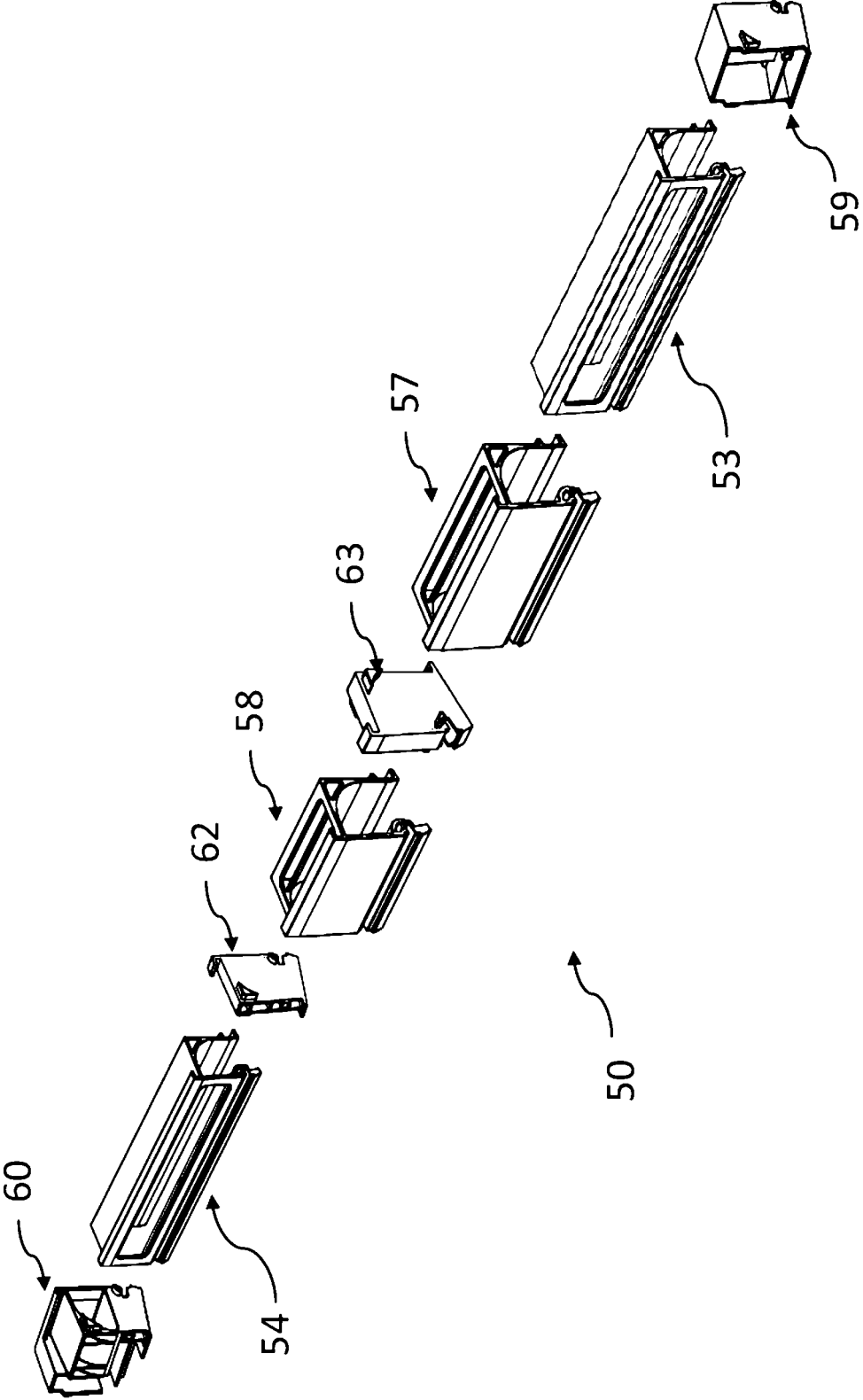

Fig. 17

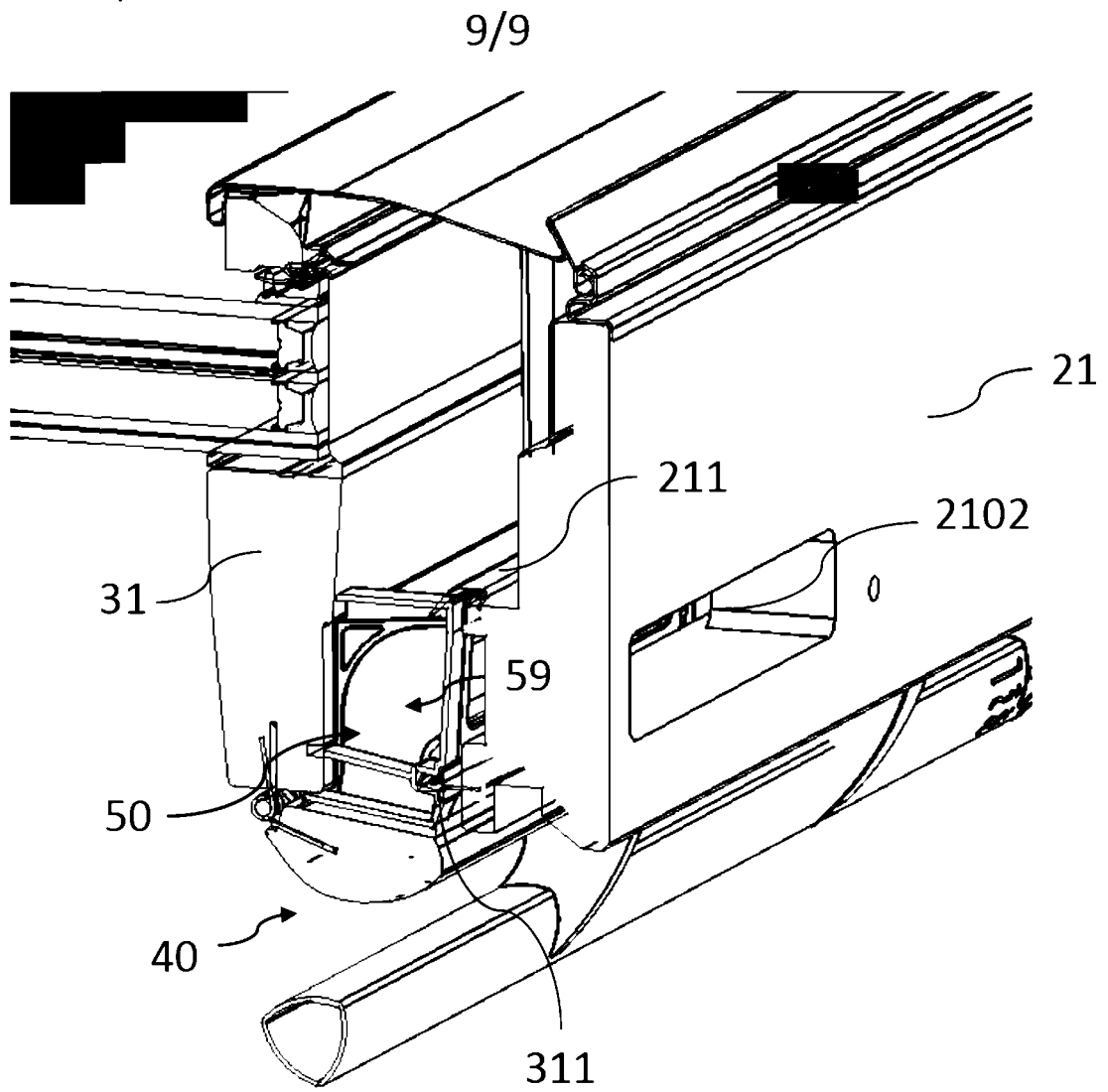

Fig. 18

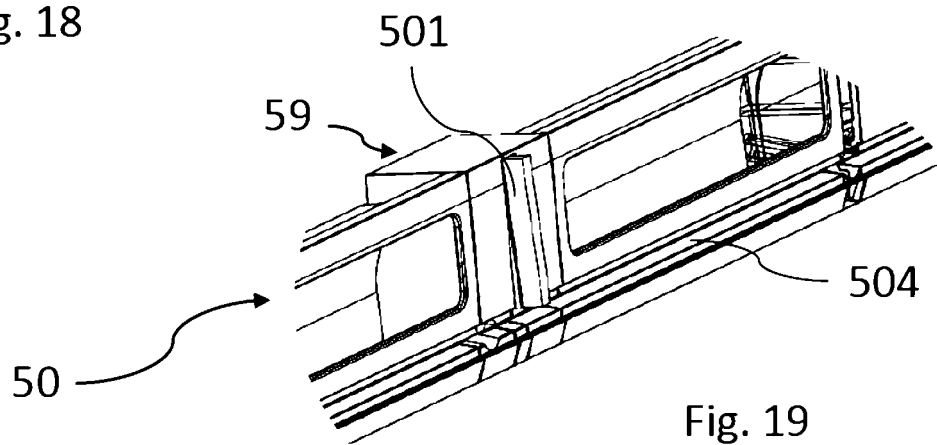

Fig. 19