

[54] **COOLING UNIT WITH ROTATING COMPRESSOR-CONDENSOR EVAPORATOR-COMBINATION**

[76] Inventor: **Rudolf Hintze**, Lessingstr. 32, Heusenstamm, Germany

[22] Filed: **Jan. 13, 1971**

[21] Appl. No.: **116,716**

[30] **Foreign Application Priority Data**

Jan. 14, 1970 Germany.....P 20 01 421.5

[52] **U.S. Cl.**.....62/499

[51] **Int. Cl.**.....F25b 3/00

[58] **Field of Search**.....62/499

[56] **References Cited**

**UNITED STATES PATENTS**

2,229,500	1/1941	Goldsmith .....	62/499 X
1,195,162	8/1916	Stair .....	62/499 X
2,156,628	5/1939	Hintze .....	62/499 X
2,811,841	11/1957	Grimshaw.....	62/499 X

2,979,921	4/1961	Sampietro .....	62/499 X
3,139,736	7/1964	Hanson.....	62/499 X

**FOREIGN PATENTS OR APPLICATIONS**

96,753	1923	Switzerland.....	62/499
--------	------	------------------	--------

*Primary Examiner*—William F. O'Dea  
*Assistant Examiner*—Peter D. Ferguson  
*Attorney*—Michael S. Striker

[57] **ABSTRACT**

An air conditioning unit is disclosed, particularly for use in a motor vehicle, which includes a stationary crankshaft having a double acting thereon. A rotatable casing receives the piston in double acting cylinder which is elongated transversely to the axis of rotation. Mounted on and rotatable with the casing are as condenser and evaporator through which refrigerant flows from the compressor to produce refrigeration.

**8 Claims, 3 Drawing Figures**

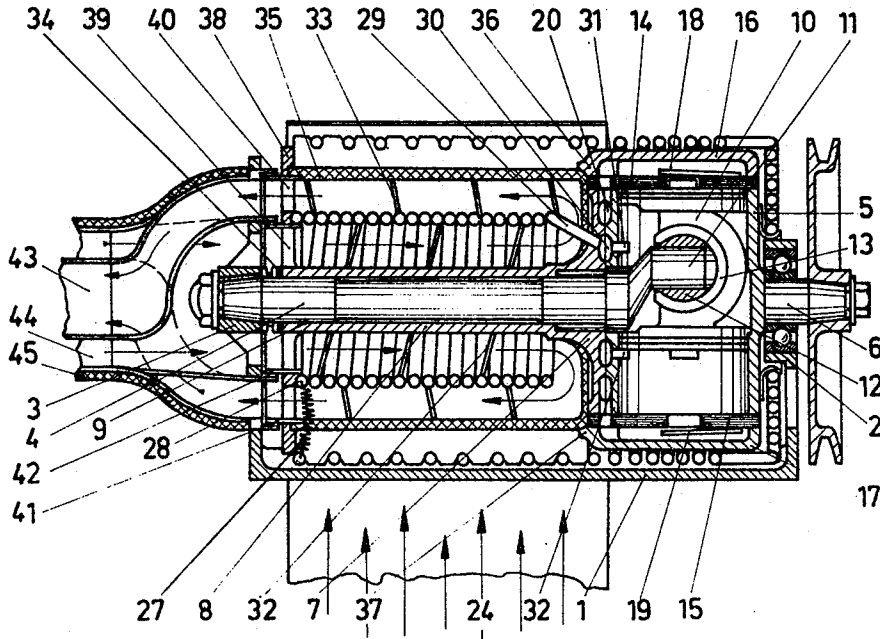
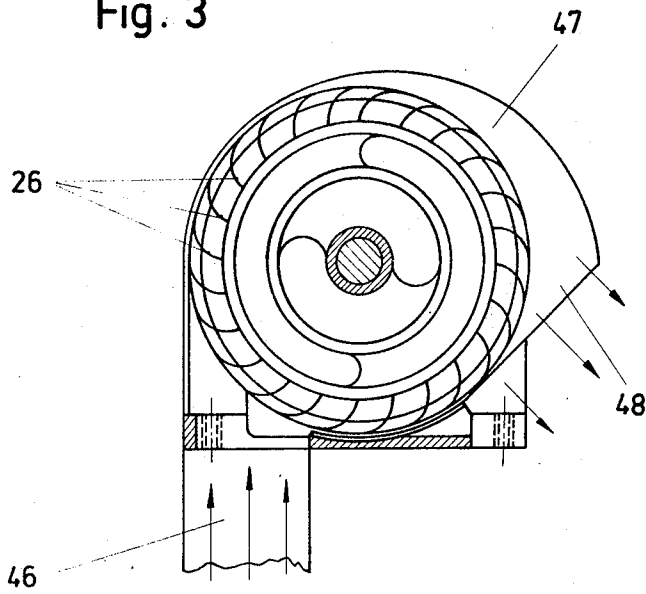



Fig. 3



## COOLING UNIT WITH ROTATING COMPRESSOR-CONDENSOR EVAPORATOR-COMBINATION

The present invention relates to refrigeration units. More particularly, the present invention relates to refrigeration units of the type which are used as air conditioners in motorcars, for example.

When installing automotive air conditioners in motorcars, it is known to separately mount the three main units of the system, the compressor, the condenser and the evaporator. The compressor is mounted near the belt drive for the radiator fan blade, the condenser in front of the radiator and the evaporator itself inside the car near the dashboard. These three main units are connected together by hoses, suited for high pressure refrigerant and oil.

This arrangement needs not only three long hoses with at least six gastight connections, but it requires a substantial degree of assembly skill, contrary to the industrial assembling of hermetically sealed refrigeration units, for example. Therefore the assembling of standard automotive airconditioning units is not only expensive, but also less safe than it could be if the three main units were combined to only one compact unit, containing all necessary parts in itself.

It is one object of the present invention to overcome the disadvantages of the standard automotive airconditioning units and to provide a compact and complete unit, which aspirates warm air out of the car and returns it in cooled condition.

It is another object of the present invention to provide an allrotating airconditioning unit, in which the compressor, the condenser and the evaporator rotate around a stationary crankshaft, the piston being forced to rotate with the cylinder but around the crank pin. This rotating around different centers results in a compressor action.

It is a further object of the present invention to provide symmetrical compressor- and heat exchanger parts, rotating around their center of gravity.

It is another object of the present invention to eliminate all hoses and their connections by providing short tube connections.

An additional object of the present invention is to provide a structure of the rotating heat exchanger fins capable of acting as blades of a blower, so that the condensing and the evaporating parts of the all rotating system have a self-ventilating action.

With the above objects in view, the present invention utilizes a double action single cylinder compressor with symmetrical design of all parts, rotating around their centers of gravity. Because two different centers exist with a distance of half the stroke, a relative movement of the piston in the cylinder takes place, resulting in a compressor action. Instead of reciprocating like stationary compressors, only a relative rotation around different centers will happen and therefore no counterweight and practically no balancing is needed and if any imbalance is found it may be removed like balancing a wheel of a motorcar.

With the symmetrical compressor also the heat exchangers are formed to symmetrical rotational cylinders, rotating around the same center which is represented by the crankshaft. Between the condenser and the evaporator an expansion device of standard design is inserted. The fins of the condenser are formed to blades and act as a blower wheel, which may be sur-

rounded by a blower housing. The evaporator tube spiral with its supporting helical spiral pump takes in the warmed air, cooling it and exhausting it through the inside passage of a double walled airhose, the other passage of which will conduct the warmed air from the car to the cooling unit. This prevents the cooled air from becoming warmed up by the hot air, for example in the engine compartment. Suitable insulation prevents any temperature exchange between the evaporator and the condenser.

Besides the self-ventilating action of the condenser and the evaporator design, additional electrical blowers may help to transport the air.

As a result of the all rotating action of the unit and the absence of vibration, the operational speed may be raised and with that the refrigeration capacity enlarged, and at the same time also the heat exchanging value. As in standard stationary compressors, a rotary seal is used to secure tightness between the stationary and the rotating parts of the unit. Also as in standard airconditioning units in motorcars, a magnetic clutch may engage the all rotating unit, directed by a thermostat.

The novel features which are considered as characteristic for the invention are set forth in particular in the appended claims. The invention itself, however, both to its construction and its method of operation, together with additional objects and advantages thereof, will be best understood from the following description of specific embodiments when read in connection with the accompanying drawing in which:

FIG. 1 shows a longitudinal sectional view of a preferred embodiment of the present invention;

FIG. 2 is a top view of FIG. 1; and

FIG. 3 is an end view, showing primarily the blower arrangement.

Referring now to the drawing and in particular to FIG. 1, it will be seen that a frame 1 has a bearing 2 on the driving side and at the opposite end a mount 3 for the stationary crankshaft 4. In the bearing 2 is arranged the pivot 6, which is a part of the compressor cylinder 5. On the opposite side of this cylinder is provided a flange 7, the tubular extension 8 of which surrounds the crankshaft 4, forming a bearing 9 and a needle roller bearing at 7.

While the cylinder 5 is able to rotate with the pivot 6 within the bearing 2 and at its opposite side in the bearing 9 (note the seal 34) around the crankshaft 4, the piston 10 rotates around another center, formed by the crankpin 11. Thus the reciprocating motion of a piston within a conventional stationary compressor is replaced in this rotating design of the present invention by an only relative rotating motion of both parts around different centers. This relative motion is induced by the sliding block 12, sliding in the guide 13 of the piston 10. The sliding block is also symmetrical and rotates around the crankpin 11; therefore no counterweight is needed.

Despite the fact that only one cylinder and only one piston is in use, the construction is symmetrical and the cylinder terminated at both ends with the same valve plates 14 and 15 and also the same valve covers 16 and 17 this, and the fact that these parts are of the same weight and spaced the same distance from the center of the crankshaft, will secure the theoretic and practical balance of the rotating compressor parts. The same is

true for the piston, which is also symmetric in design and weight.

The relief valves 18 and 19 will guide the compressed refrigerant into the concentric distributor 20 and through a notillustrated muffler on the outlet 21 out of the compressor into the concentric tube windings 22 and 23, where the gas is able to dissipate its overheat and will then enter the condenser tube 24, which is coiled around the finned body 25, the fins of which are formed as blades 26, resulting in a blower wheel which rotates within the blower housing 47 and takes in the cooling air through the duct 46, blowing it out through the other duct 48.

The entrance of this cooling air may take place outside of the engine compartment, where the air is not yet warmed up.

Between the end of the condenser and the beginning of the evaporator coil an expansion device 27 of known design is provided, a capillary tube for example, which will transfer the refrigeration fluid to the also coiled rotating evaporator 28, where the fluid will evaporate. After passing the evaporator coil 28 the gas enters through the tube 29 into the ring-shaped distributor 30.

Out of this distributor the gas will pass via the slot-ports 31 and 32 and then enter the cylinder, beginning a new cycle. The coiled evaporator tube 28 is supported on the tubular extension 8 by spiral fins 32, which will suck in the warmed air coming out of the passenger compartment, while the outer fins 33 in the opposite direction will press the cooled air over the outside of the evaporator 28 into the inside of the double walled air hose 43. The insulation tube 35, separating the evaporator chamber from the condenser part of the rotating heat exchanges, is suspended by the centering webs 36 and 37 at its cylinder front and on the opposite side by the end flange 38, which is a part of the tubular extension 8. This flange 38 has the inlets 39 for the incoming warmed air and the outlets 40 for the outgoing cooled air.

The rotating flange 38 separates the warmed air from the cooled air via the seals 41 and 42, while insulation 45 prevents heat exchange between any outside hot air and the double walled air hose 43 and 44.

It will be understood that this invention, which has in view more compact automotive airconditioning units, comprehending the till now separated compressor, condenser and evaporator devices in form of only one unit which is self-ventilated, uses also many elements of already known design besides the described improvements to make the complete airconditioner. The arrangement of the heat exchangers may be changed with regard to the air guide, for example side by side instead of the described telescopic design, if the all rotating design of the compressor, the condenser and the evaporator is maintained. Also the self-ventilation may be assisted by additional electric blowers, controlled by thermostats.

I claim:

1. In an airconditioning unit, in combination, a stationary crankshaft having two axially arrayed sections; a compressor casing mounted for rotation about said crankshaft coaxially therewith, said casing having a

first portion surrounding one of said sections and a second portion surrounding the other of said sections and being configured as a symmetrical doubleacting cylinder elongated transversely of the longitudinal axis of said crankshaft, said cylinder having opposite end-ports of identical weight and spaced at identical distances from said longitudinal axis; a piston mounted in said cylinder connected with said other section of said crankshaft; heat exchange means fixedly surrounding and rotatable with said first portion about said one section and communicating with said cylinder for receiving a fluid stream issuing therefrom, said heat exchange means including a condenser and an operatively associated evaporator one of which is located within the confines of the other, and a separator of thermally insulating material interposed between said evaporator and condenser; and a plurality of blades provided on said heat exchange means for effecting movement of ambient air relative to said heat exchange means in response to rotation of the latter and for heat exchange between the moving air and said fluid stream.

2. In an airconditioning unit as defined in claim 1, wherein said piston is mounted for turning movement about an additional axis laterally offset from said longitudinal axis, said piston being symmetrical in its weight and configuration with reference to said additional axis.

3. In an airconditioning unit as defined in claim 2, further comprising motion-transmitting means operatively associated with said piston for converting the rotary motion of the same about said additional axis into a reciprocatory motion relative to said cylinder which rotates about said longitudinal axis.

4. In an airconditioning unit as defined in claim 1, said condenser being configured as a body of rotation and having a circumference provided with some of said blades which together constitute an impeller.

5. In an airconditioning unit as defined in claim 1, said evaporator being located within the confines of said condenser and said separator being a sleeve.

6. In an airconditioning unit as defined in claim 5, said evaporator being of tubular configuration and surrounding said first portion with clearance; and further comprising helical supporting web means in said clearance, supporting said evaporator on said first portion for rotation with both and operative for effecting aspiration and movement of air in one axial direction of said clearance.

7. In an airconditioning unit as defined in claim 6, said condenser surrounding said evaporator and defining with the same an annular space; and further comprising additional helical supporting web means in said space, supporting said condenser on said evaporator and being operative for effecting aspiration and movement of air through said space in an axial direction opposite to said one direction.

8. In an airconditioning unit as defined in claim 7; further comprising a double-walled conduit having a pair of concentric air passages one of which communicates with said clearance and the other of which communicates with said space.

\* \* \* \* \*