

A. G. MOWBRAY.
 Improvement in Feed-Regulators for Middling-Separators.

No. 131,625. Patented Sep. 24, 1872.

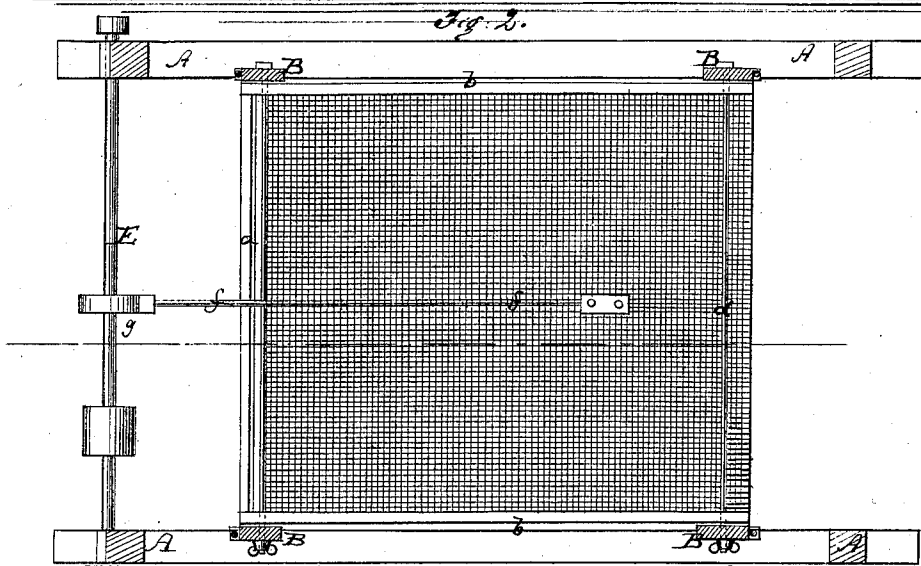
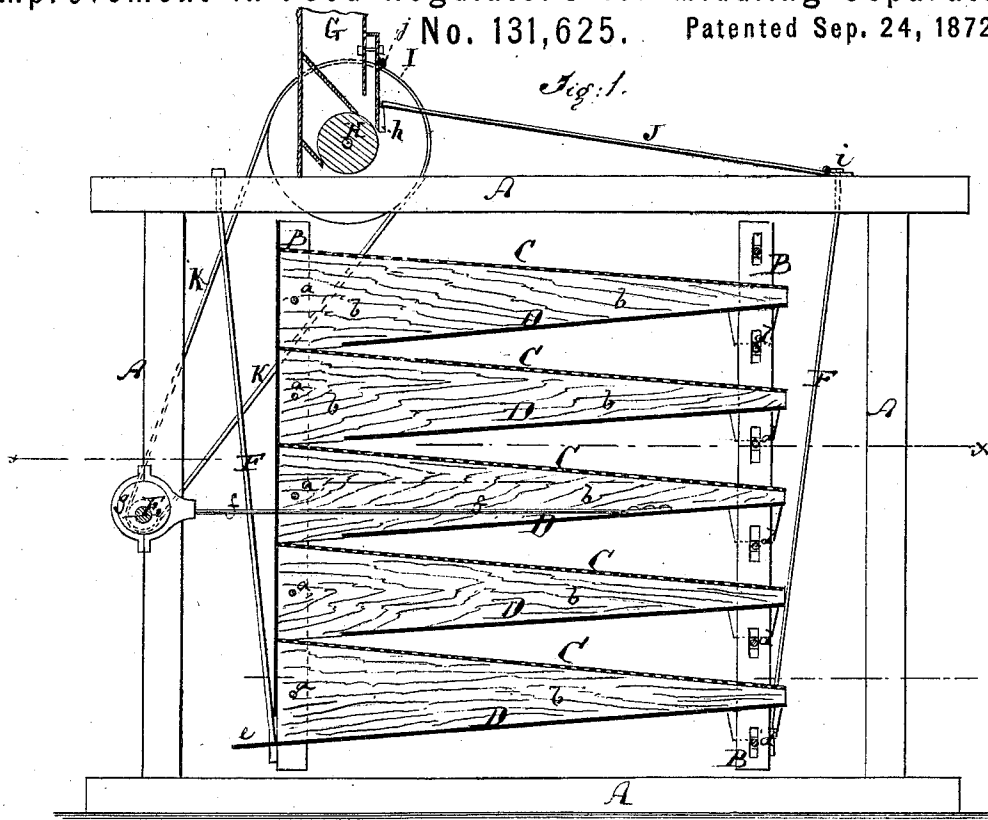

Witnesses:

Chas. Nida
H. A. Graham

Inventor:

A. G. Mowbray
 PER *Munnell*
 Attorneys.

UNITED STATES PATENT OFFICE.

ALFRED G. MOWBRAY, OF STOCKTON, MINNESOTA.

IMPROVEMENT IN FEED-REGULATORS FOR MIDLINGS-SEPARATORS.

Specification forming part of Letters Patent No. 131,625, dated September 24, 1872.

To all whom it may concern:

Be it known that I, ALFRED G. MOWBRAY, of Stockton, in the county of Winona and State of Minnesota, have invented a new and Improved Middlings-Separator, of which the following is a specification:

Figure 1 represents a vertical longitudinal section of my improved middlings-separator. Fig. 2 is a horizontal section of the same.

Similar letters of reference indicate corresponding parts.

This invention relates to an improved apparatus for separating middlings from bran; and consists in the construction and arrangement of certain parts hereinafter claimed, and which I will proceed to describe in connection with other parts necessary to form a complete or operative machine.

A in the drawing represents the stationary supporting-frame of my improved separator. B B are the upright posts of the movable frame, in which five, more or less, sieves, C C, are secured. Each of these sieves is inclined, and all are nearly or entirely parallel with each other, as shown, and are secured at one side to the uprights B B by bolts *a a*, which pass through the pendent sides *b b* of the sieves, while their other lower ends rest on bolts *d d*, as is clearly indicated in Fig. 1. The sieves can be more or less inclined by letting the bolts *d* move down or up in the slots, through which they pass in the uprights. While being thus regulated as to inclination the sieves swing on the bolts *a*. Under each sieve is a plate, D, inclined in an opposite direction to the sieve, and terminating before reaching the sieve below, except the lowermost plate D, which may be extended, as shown, to constitute the final discharge-spout *e* for the mid-

dlings. By a rod, *f*, connecting with one of the plates D, the frame B with its sieves is subjected to the action of an eccentric, *g*, mounted on a shaft, E, that hangs on the frame A. When the shaft E is rapidly revolved the sieves are all moved back and forth to shake the material on them and cause the desired separation of coarse from fine matter. Springs F, connecting with the uprights B at opposite sides of the sieves, tend to balance the moving frame and hold it suspended from the top of the frame A, and aid in making the shaking motion sudden. The hopper G, in which the middlings are placed to be delivered to the sieves, has a bottom formed by a revolving shaft, H. J is a bar hinged to the frame A at *i*, and resting at its free end against the inclined or wedge-shaped block *h* attached to the side I of the hopper, which is hinged at *j*. This free end of said bar being vertically adjustable, the width of the opening between the side I and the roller H may be easily controlled, so as to correspondingly regulate the delivery of the material to be screened or separated.

It will be understood that the weight of the material in the hopper serves to hold the side I open sufficiently to allow the escape of the middlings, and when no more remains in the hopper the bar J will close the side I.

Having thus described my invention, I claim as new and desire to secure by Letters Patent—

The combination of the hinged bar J with the hinged side I *h* of the hopper, as shown and described.

ALFRED G. MOWBRAY.

Witnesses:

JAMES H. LOCKE,
H. W. MOWBRAY.