

(No Model.)

J. E. GILLESPIE.

STEAM GENERATOR.

No. 368,332.

Patented Aug. 16, 1887.

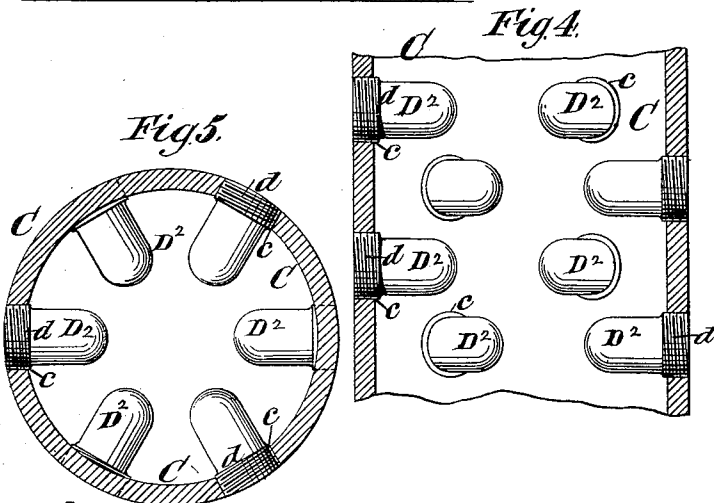
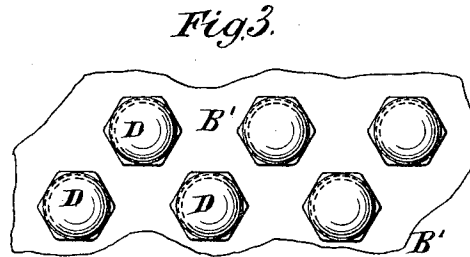
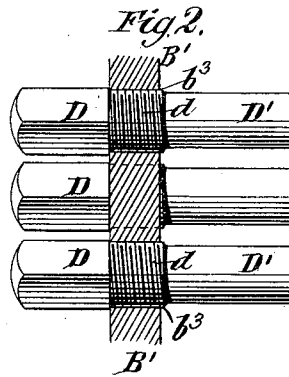
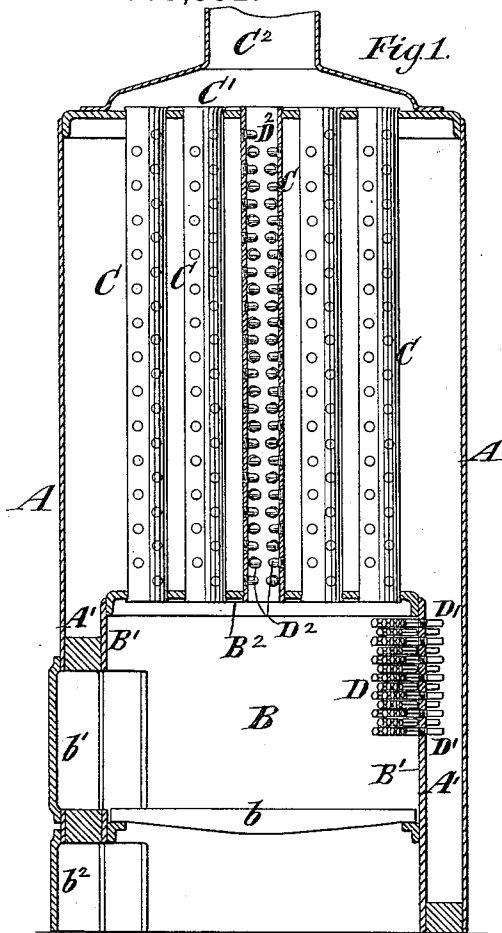

Witnesses:
O. Sundgren
Emil Hertor

Inventor:
James E. Gillespie
 by his Attys
Brown & Hall

UNITED STATES PATENT OFFICE.

JAMES E. GILLESPIE, OF WARWICK, NEW YORK.

STEAM-GENERATOR.

SPECIFICATION forming part of Letters Patent No. 368,332, dated August 16, 1887.

Application filed December 16, 1886. Serial No. 221,703. (No model.)

To all whom it may concern:

Be it known that I, JAMES E. GILLESPIE, of Warwick, in the county of Orange and State of New York, have invented a new and useful Improvement in Steam-Generators, of which the following is a specification.

The invention is more particularly intended for generators of steam fire-engines, but may be advantageously employed for generators for other purposes.

It is well known that flame and hot gases will not make intimate contact with cold iron, but will be separated therefrom by a thin layer or stratum of air, and hence iron will not receive the full benefit or transmit the full effect of the hot gases until it has become heated to such a degree that it will not repel but will permit their intimate contact with it. Where the furnace plates, tubes, or other heating-surfaces of a steam-generator are exposed on one side to water, a considerable time elapses before the iron becomes heated to such a degree as will permit the flame and hot gases to make intimate contact with it.

The object of my invention is to increase the efficiency or evaporating power of a tubular steam-generator of given size by providing heat-conductors in the tubes, on which the flame and hot gases will act more effectively than on the ordinary tube surfaces.

The invention consists in the combination, with a heating-tube for a steam-generator, of solid radial pins inserted thereinto, projecting inward from the inner surface thereof, and having their outer ends flush with the exterior of the tube and destitute of any projection beyond the circular exterior of the tube, so as to permit of the introduction and securing of the tubes in the usual way in tube-holes in the tube-sheets.

The invention also consists in the combination, with a heating-tube for a steam-generator, of solid radial pins inserted thereinto, projecting inward from the inner surface thereof, and having their outer ends flush with the exterior of the tube and destitute of any projection beyond the circular exterior of the tube, said pins being arranged in rows lengthwise of the tube, leaving continuous spaces between the pins for the passage of the wings of a flue-brush.

In the accompanying drawings, Figure 1 is a vertical section of an upright tubular steam generator or boiler embodying my invention. Fig. 2 is a sectional view of a portion of the vertical plate forming the fire-box of the boiler. Fig. 3 is a face view of a portion of such plate, and Figs. 4 and 5 are respectively a vertical section and a transverse section of a portion of one of the fire-tubes of the boiler or generator. Figs. 2, 3, 4, and 5 are upon a much larger scale than Fig. 1, and are, indeed, drawn about full size.

Similar letters of reference designate corresponding parts in all the figures.

A designates the outer shell or cylinder of an ordinary upright tubular boiler, having within its lower end a furnace or fire-box, B, provided with the usual grate, *b*, and fire and ash-pit doors *b'* *b''*.

The furnace B is surrounded by an annular water-leg, A', the outer wall of which is formed by the shell or cylinder A, and the inner wall of which is formed by the upright plates B'. The furnace B is completed by the crown-sheet B², from which the fire tubes or flues C extend to the top of the boiler. The products of combustion from the furnace B pass through the tubes C and are collected by a cowl or hood, C', and conducted away by a smoke-pipe, C².

In order to increase the efficiency of the tubes C, I supply them with pins or projections D², which are radial to the tubes, as shown best in Fig. 5, and are secured by screw-threads *d* within threaded holes or sockets *c* formed in the tubes. The pins D² in the tubes have not any outward projection whatever beyond the exterior of the tubes, as, if they had, they would prevent the insertion of the tubes through the tube-holes provided for them in the tube-plates. The pins D² may therefore be screwed into the tubes from the outer side thereof, and may then be cut off flush with the circular exterior of the tubes.

The pins D² serve to increase the heating-surface of the tubes and have great value and effectiveness as compared with the heating-surface of ordinary tubes. The very thin metal of which the tubes are made prevents them when exposed to water on the opposite side from soon becoming heated to a degree

which will permit the hot gases to make direct contact with their inner surfaces, but the pins soon become highly heated and serve as excellent conductors of heat.

5 In order that the tubes may be readily cleaned by a brush in the usual manner, I arrange the pins D^2 in lines or rows which extend lengthwise of the tubes, and they will then afford provision for cleaning the tubes by a
10 brush having its wings or operative portions suitably arranged with relation to lines or rows of pins D^2 .

In addition to the pins D^2 in the tubes, I may also insert similar pins, D , into the furnace-plates B' , save that such pins also form
15 projections extending into the water-space; but these latter pins are not included in my invention.

I am aware that it has been proposed to insert in the plates of boilers pins similar to the pins D , before described, and having about
20 equal projection on each side of the plates, and that where the structure in which the pins are is intended for evaporating substances to dryness or such other use as would render the
25 projections on the side of the plate opposite the fire objectionable it has been proposed to secure the pins in place by inserting them in holes in the plate and riveting over their ends.

30 Where the pins are inserted in the interior of a heating-tube, any projection whatever, even that formed by riveting over the end of the pins on the exterior of the tube, would render

it impossible to insert the tube through the ordinary tube-holes in the tube-plates, and I
35 therefore, after inserting the pins D^2 , cut off their outer ends flush with the circular exterior of the tube, leaving absolutely no projections on the exterior surface of the tube.

What I claim as my invention, and desire
40 to secure by Letters Patent, is—

1. The combination, with a heating-tube for a steam-generator, of solid radial pins inserted thereinto and projecting inward from the inner surface thereof, but having their outer
45 ends flush with the exterior of the tube and destitute of any projection beyond the circular exterior of the tube, so as to permit of the introduction and securing of the tube in the usual way in tube-holes formed in the tube-
50 sheets, substantially as herein described.

2. The combination, with a heating-tube for a steam-generator, of solid radial pins inserted thereinto and projecting inward from the inner surface thereof, but having their outer
55 ends flush with the exterior of the tube and destitute of any projection beyond the circular exterior of the tube, the said pins being arranged in rows lengthwise of the tube, leaving spaces between the pins for the passage of the
60 wings of a flue-brush, substantially as herein described.

JAMES E. GILLESPIE.

Witnesses:

FREDK. HAYNES,
HENRY J. MCBRIDE.