

Dec. 8, 1931.

L. O. PARKER

1,835,239

SIGNAL DEVICE

Filed Feb. 3, 1927

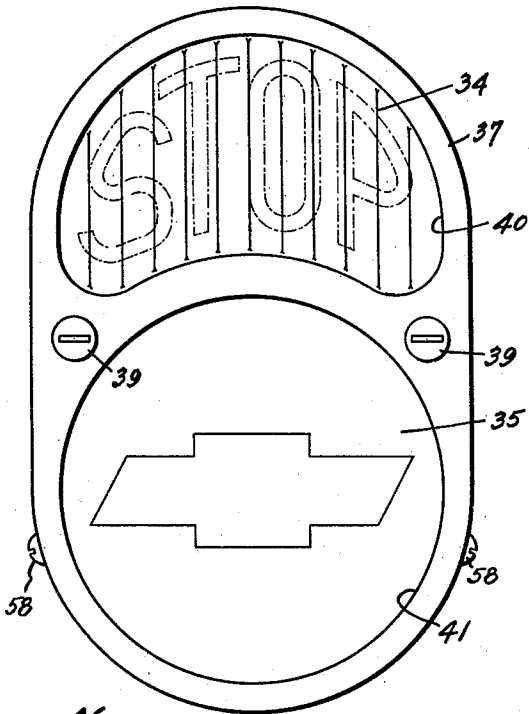

Fig. 1

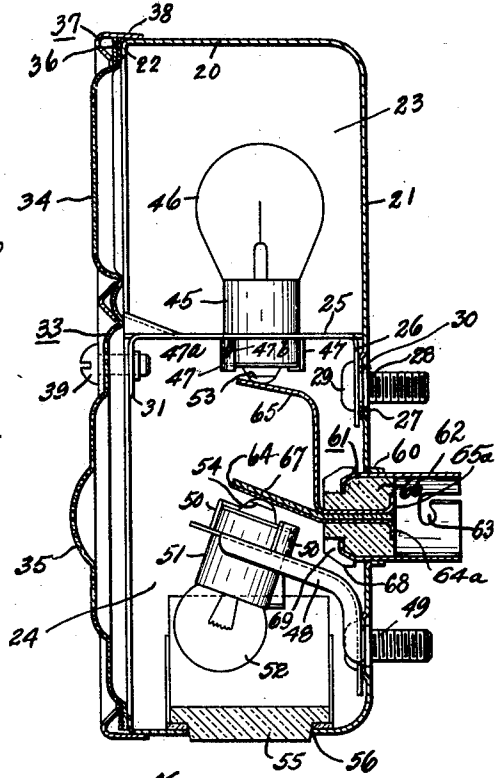

Fig. 3.

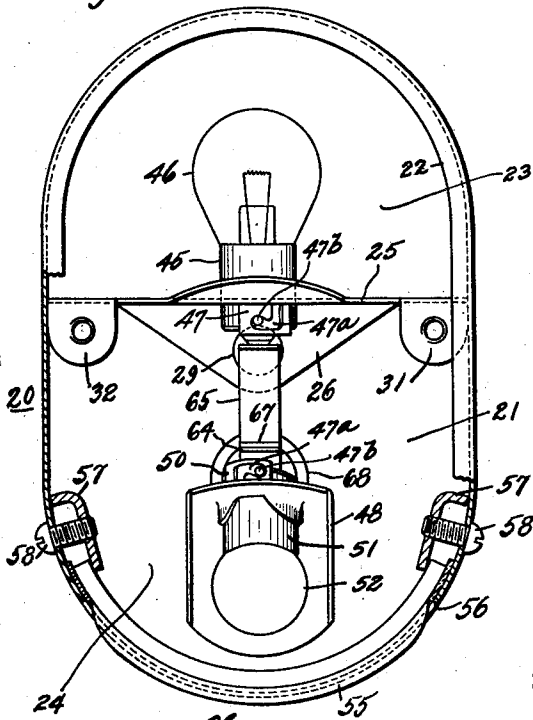

Fig. 2

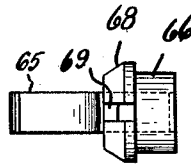

Fig. 4

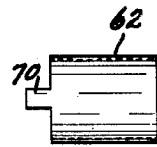

Fig. 5

Inventor

Lisle O. Parker

Spencer Hardman & Fisher
his Attorneys

UNITED STATES PATENT OFFICE

LESLIE O. PARKER, OF ANDERSON, INDIANA, ASSIGNOR TO DELCO-REMY CORPORATION,
OF ANDERSON, INDIANA, A CORPORATION OF DELAWARE

SIGNAL DEVICE

Application filed February 3, 1927. Serial No. 165,516.

This invention relates to improvements in signal devices, and more particularly to signal devices used in connection with motor vehicles.

5 It is among the objects of the present invention to provide a combined tail lamp and stop signal of simple structure and design, which may be produced at comparatively low cost and which may readily be assembled or disassembled to replace parts thereof.

10 Further objects and advantages of the present invention will be apparent from the following description, reference being had to the accompanying drawings wherein a preferred embodiment of one form of the present invention is clearly shown.

In the drawings:

Fig. 1 is a front elevation of the signal device;

20 Fig. 2 is a view similar to Fig. 1 with the cover and frame removed, certain portions being shown in section for the sake of clearness;

25 Fig. 3 is a vertical section of the signal device; and

Figs. 4 and 5 are detail views of the connector plug.

30 Referring to the drawings, the signal device comprises a case 20 having a back wall 21, the outer or open edge of the case being provided with an inwardly extending flange 22. The case is divided into two compartments 23 and 24 by a partition 25, said partition having a depending flange 26 which lies adjacent to and engages the depressed portion 27 in the rear wall 21. The flange 26 and the depressed portion 27 are provided with apertures, in alignment when the partition is in position in the case. The shank portion 28 of a headed screw 29 extends through said aligned apertures and is upset over the rear wall as at 30 rigidly to secure the partition to said rear wall. This shank portion 28 extends beyond the rear surface of the wall and provides a mounting stud for the signal device. The partition is provided with two depending ears 31 and 32, having screw threaded apertures, and lying in the plane of the casing flange 22.

50 A translucent cover 33 having lens por-

tions 34 and 35 of different type, closes the open end of the casing 20 so that the lense 34 provides a cover for compartment 23 and the lense 35 a cover for the compartment 24. A gasket 36 fits about the outer surface of the cover 33, said gasket being engaged by the inner edge of a frame 37, which has a flange 38 adapted to fit about the casing 20. The frame 37 is provided with two apertures aligning with the apertures in the ears 31 and 32 when the frame is in position on the casing, screws 39 extending through said apertures in the frame and screwing into the apertures in the ears 31 and 32 to hold said frame securely in position on the casing. Two openings 40 and 41 are provided in the frame, the opening 40 fitting about the lense 34, while the opening 41 fits about the lense 35 of the cover 33. From this it may be seen that the frame 37 holds the cover 33 in position on the case, said frame in turn being secured to the case by means of screws which engage the ears of partition 25.

Partition 25 has an aperture for receiving the base 45 of lamp 46, said partition supporting the lamp so that it will be positioned in the compartment 23 in direct alignment with the lens 34 of the cover. Adjacent the edge of the aperture which receives the lamp base 45, the partition 25 is provided with downwardly extending lug portions 47, slotted as at 47a, for receiving the laterally extending pins 47b with which electric lamps are usually provided.

Within the compartment 24 of the case there is provided an angular bracket 48 secured to the rear wall 21 of the casing by a stud 49, in a similar manner in which the ear 26 of the partition is secured to the rear wall of the case. The extending portion of the shank 49 provides additional mounting studs for the signal device. The bracket 48 like partition 25 is provided with extending lug portions 50 forming a socket for receiving the base 51 of the lamp 52.

In Fig. 3 it will be seen that the lamps 46 and 52 are so supported on the partition and bracket respectively that their terminals 53 and 54 extend toward each other within the compartment 24. A clear glass lens 55 cov-

55

60

65

70

75

80

85

90

95

100

ers an aperture 56 in the bottom wall of the casing, said glass being secured to the bottom of the casing by means of clamps 57 held in position by screws 58. This clear glass lens is adjacent the lamp 52 so that the rays thereof may project through said lens onto the license plate, mounted directly beneath the signal device.

An aperture surrounded by a flange 60 is provided in the rear wall 21 of the case. Said aperture receives the connector 61 which includes a metal sleeve 62 for receiving a double terminal plug (not shown) having a laterally extending pin for engaging a bayonet slot 63. The sleeve 62 is joined by welding to the flange 60 and supports a non-conducting core 66 carrying spring contacts 64 and 65 insulated by a non-conducting strip 67. The ends 64a and 65a of these contacts provide terminals for receiving the two terminals of the double terminal plug referred to. The contacts 64 and 65 engage lamp terminals 54 and 53 respectively when lamps 52 and 46 are assembled as shown.

The core 66 has an enlarged head portion 68 provided with slots 69 for receiving the tongue portions 70 of the sleeve 62. The tongues 70 are forced into the slots 68 and are to secure core 66 to the sleeve 62.

From the foregoing description it may be seen that the lamps, if burned out, may be readily replaced by the removal of the screws 39 which permits removal of the cover and frame, thus making the lamps accessible.

The connector core 66 may be removed from the sleeve 62 after prying the tongues 70 away from the head 68 of the core 66.

The plane of the filament of lamp 46 should be parallel with the plane of lens 34 for best illumination.

Substantially all parts of the device may be produced by the stamping process, thus maintaining the cost of production at a minimum.

While the form of embodiment of the present invention as herein disclosed, constitutes a preferred form, it is to be understood that other forms might be adopted, all coming within the scope of the claims which follow.

What is claimed is as follows:

1. A tail and signal lamp comprising a casing, a partition in the casing dividing it into upper and lower compartments, said partition being provided with integral lamp socket holding means, ears on the front portion thereof, and a single broad-based, substantially triangular, ear on the rear portion, a bolt passing through the latter ear and the rear of the casing with its threaded portion outside of the casing and including means for rigidly fastening the partition and casing together.

2. The structure as set forth in claim 1 with a lamp supporting bracket in the lower com-

partment having a base portion engaging the rear of the casing and an arm portion provided with an integral lamp holding means, a second bolt extending through the bracket base and the casing with its screw threaded portion outside of the casing and including means for rigidly fastening the bracket to the casing, the bolts being located substantially in the median vertical plane of the casing, and means including a socket portion in the casing between the bolts, for making detachable connection for the center contacts of lamps when located in said holders.

In testimony whereof I hereto affix my signature.

LESLIE O. PARKER.