

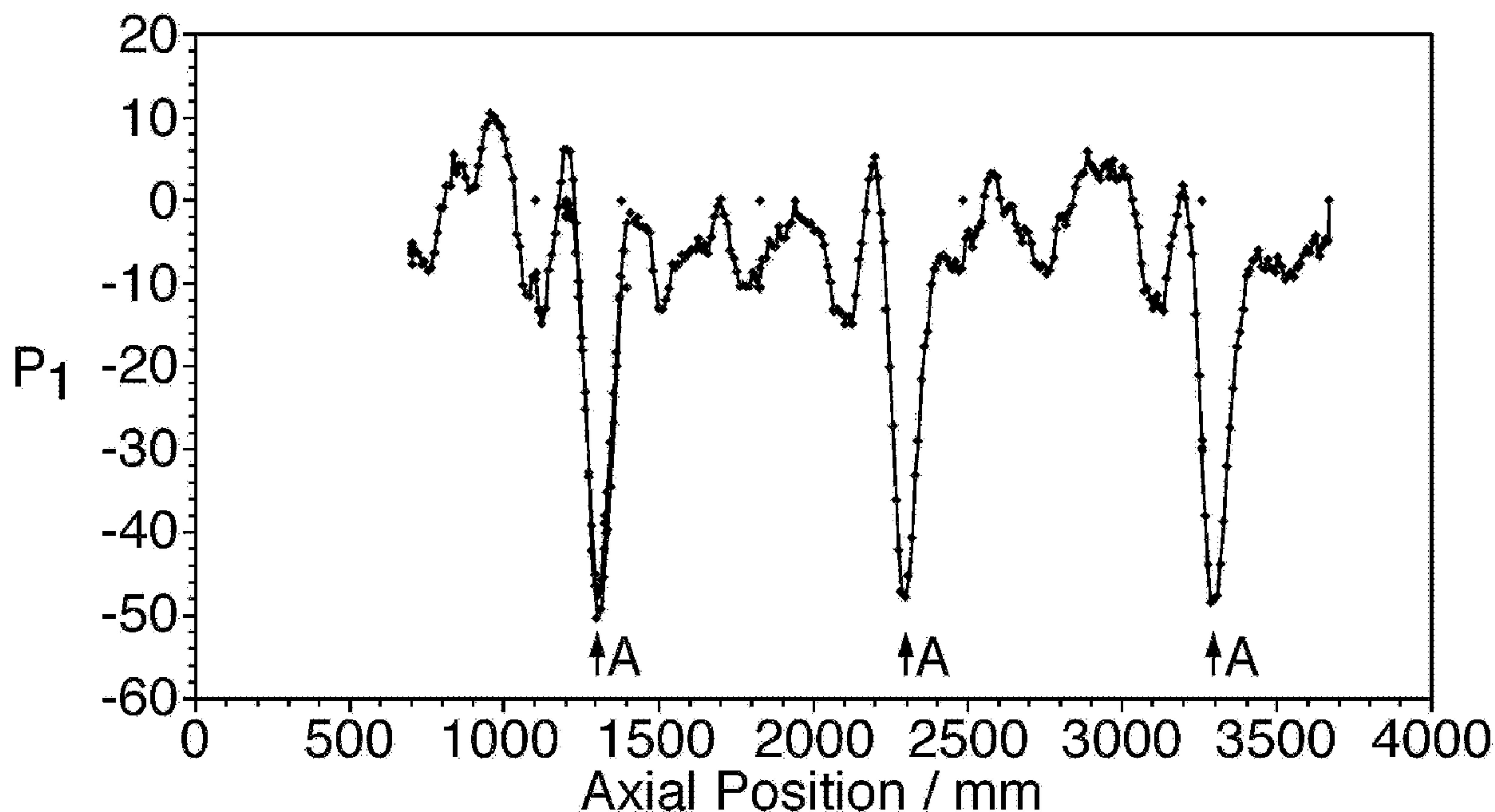

(86) Date de dépôt PCT/PCT Filing Date: 2005/12/14
 (87) Date publication PCT/PCT Publication Date: 2006/06/29
 (85) Entrée phase nationale/National Entry: 2007/05/17
 (86) N° demande PCT/PCT Application No.: GB 2005/050248
 (87) N° publication PCT/PCT Publication No.: 2006/067524
 (30) Priorité/Priority: 2004/12/23 (GB0428138.2)

(51) Cl.Int./Int.Cl. *G01N 27/83* (2006.01),
G01N 27/90 (2006.01)
 (71) Demandeur/Applicant:
ESR TECHNOLOGY LIMITED, GB
 (72) Inventeurs/Inventors:
BUTTLE, DAVID JOHN, GB;
DALZELL, WILLIAM, GB
 (74) Agent: GOWLING LAFLEUR HENDERSON LLP

(54) Titre : DETECTION DE DEFAUTS DANS DES STRUCTURES EN ACIER MULTIFIL SOUPLES
 (54) Title: DETECTING FAILURES IN FLEXIBLE MULTISTRAND STEEL STRUCTURES



(57) **Abrégé/Abstract:**

A flexible elongate structure, such as a flexible riser (10) for connecting oil and gas wells to floating production platforms, comprising at least one layer (20) of steel wires near the surface which extend at least partly along the length of the structure, can be monitored by inducing a magnetic field in the steel wires using an electromagnetic coil, and monitoring the magnetic flux density near the surface of the structure so as to detect if any wires have broken. Measurements are made at two different frequencies, the lower frequency giving an output dependent both on stresses and on the number of adjacent wires in the layer (20), and the higher frequency giving an output primarily dependent on the number of these wires. By comparing these two measurements a corrected output parameter (P) may be obtained that is indicative only of stress. A break in a wire can be expected to change the stress in that and adjacent wires.

(12) INTERNATIONAL APPLICATION PUBLISHED UNDER THE PATENT COOPERATION TREATY (PCT)

(19) World Intellectual Property Organization
International Bureau



(43) International Publication Date
29 June 2006 (29.06.2006)

PCT

(10) International Publication Number
WO 2006/067524 A1

(51) International Patent Classification:

G01N 27/83 (2006.01) G01N 27/90 (2006.01)

(21) International Application Number:

PCT/GB2005/050248

(22) International Filing Date:

14 December 2005 (14.12.2005)

(25) Filing Language:

English

(26) Publication Language:

English

(30) Priority Data:

0428138.2 23 December 2004 (23.12.2004) GB

(71) Applicant (for all designated States except US): **ESR TECHNOLOGY LIMITED** [GB/GB]; Whittle House, 410 The Quadrant, Birchwood Park, Warrington Cheshire WA3 6FW (GB).

(72) Inventors; and

(75) Inventors/Applicants (for US only): **BUTTLE, David John** [GB/GB]; 29, Upthorpe Road, Wantage Oxfordshire OX12 7DF (GB). **DALZELL, William** [GB/GB]; 21, St. Catherine's Road, Winchester Hampshire SO23 0PP (GB).

(74) Agent: **MANSFIELD, Peter Turquand**; ipsolutions, 329 Harwell Business Centre, Didcot Oxfordshire OX11 0QJ (GB).

(81) Designated States (unless otherwise indicated, for every kind of national protection available): AE, AG, AL, AM, AT, AU, AZ, BA, BB, BG, BR, BW, BY, BZ, CA, CH, CN, CO, CR, CU, CZ, DE, DK, DM, DZ, EC, EE, EG, ES, FI, GB, GD, GE, GH, GM, HR, HU, ID, IL, IN, IS, JP, KE, KG, KM, KN, KP, KR, KZ, LC, LK, LR, LS, LT, LU, LV, LY, MA, MD, MG, MK, MN, MW, MX, MZ, NA, NG, NI, NO, NZ, OM, PG, PH, PL, PT, RO, RU, SC, SD, SE, SG, SK, SL, SM, SY, TJ, TM, TN, TR, TT, TZ, UA, UG, US, UZ, VC, VN, YU, ZA, ZM, ZW.

(84) Designated States (unless otherwise indicated, for every kind of regional protection available): ARIPO (BW, GH, GM, KE, LS, MW, MZ, NA, SD, SL, SZ, TZ, UG, ZM, ZW), Eurasian (AM, AZ, BY, KG, KZ, MD, RU, TJ, TM), European (AT, BE, BG, CH, CY, CZ, DE, DK, EE, ES, FI, FR, GB, GR, HU, IE, IS, IT, LT, LU, LV, MC, NL, PL, PT, RO, SE, SI, SK, TR), OAPI (BF, BJ, CF, CG, CI, CM, GA, GN, GQ, GW, ML, MR, NE, SN, TD, TG).

Declarations under Rule 4.17:

- as to applicant's entitlement to apply for and be granted a patent (Rule 4.17(ii))
- as to the applicant's entitlement to claim the priority of the earlier application (Rule 4.17(iii))

Published:

- with international search report

For two-letter codes and other abbreviations, refer to the "Guidance Notes on Codes and Abbreviations" appearing at the beginning of each regular issue of the PCT Gazette.

(54) Title: DETECTING FAILURES IN FLEXIBLE MULTISTRAND STEEL STRUCTURES

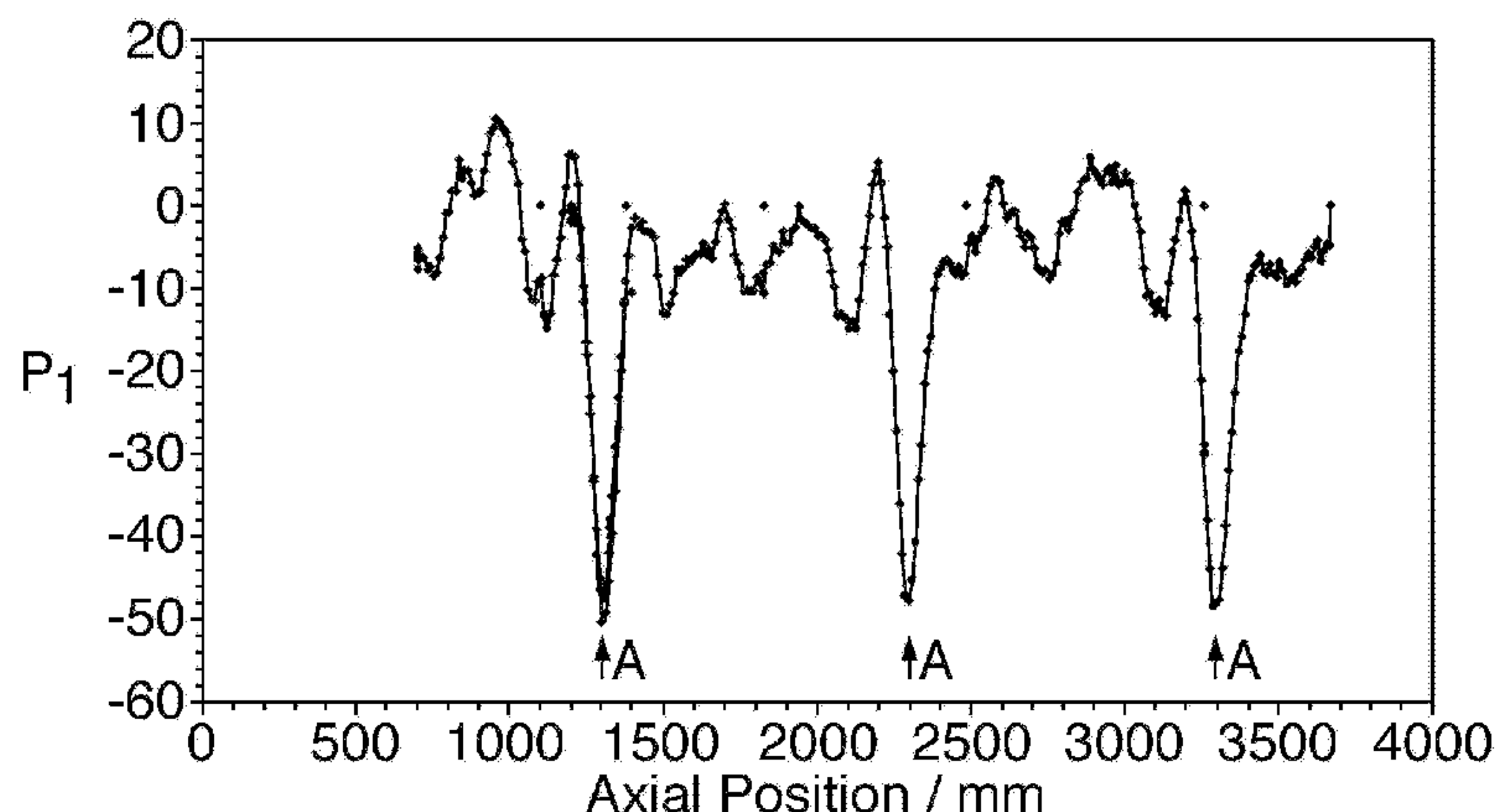

(57) Abstract: A flexible elongate structure, such as a flexible riser (10) for connecting oil and gas wells to floating production platforms, comprising at least one layer (20) of steel wires near the surface which extend at least partly along the length of the structure, can be monitored by inducing a magnetic field in the steel wires using an electromagnetic coil, and monitoring the magnetic flux density near the surface of the structure so as to detect if any wires have broken. Measurements are made at two different frequencies, the lower frequency giving an output dependent both on stresses and on the number of adjacent wires in the layer (20), and the higher frequency giving an output primarily dependent on the number of these wires. By comparing these two measurements a corrected output parameter (P) may be obtained that is indicative only of stress. A break in a wire can be expected to change the stress in that and adjacent wires.

WO 2006/067524 A1

- 1 -

Detecting Failures in Flexible Multistrand Steel Structures

This invention relates to a method and apparatus for
5 monitoring flexible multistrand steel structures such as
cables, hoses or risers, for detecting failures.

Flexible risers are used to connect oil and gas
wells to floating production platforms, the flexible
10 riser being a steel-wire-reinforced flexible hose.
Typically such a riser is connected to a turret on the
floating platform, the turret providing some degree of
rotation, and the flexible riser is typically hundreds or
thousands of metres long. Failure in such a flexible
15 riser can lead to significant quantities of oil leaking
into the environment. It has been found that such risers
typically fail close to the point at which the riser is
connected to the turret, or to a support point along its
length, this failure being due to the fatigue loading
20 endured by the riser at the point where the forces are
greatest due to wave motion and rotation of the floating
platform. This failure mode is recognised, but there
exists no technology capable of inspection of such risers
to warn of catastrophic failure, particularly with the
25 flexible riser in situ connected to the turret and
carrying a product.

An electromagnetic probe may be used to detect
stress in the reinforcing wires or ligaments, but the
30 measurements are complicated by the gaps between adjacent
ligaments, which are typically not uniform and may vary
during use.

According to present invention various provided a
35 method for monitoring a flexible elongate structure with
a generally cylindrical surface, the structure comprising

- 2 -

at least one layer of steel ligaments near the cylindrical surface, the steel ligaments extending at least partly along the length of the structure, the method comprising inducing an alternating magnetic field less than saturation in the steel ligaments using an electromagnet with spaced-apart poles adjacent to the cylindrical surface and monitoring the alternating magnetic flux density near the said cylindrical surface in the vicinity of the said electromagnet, from the detected flux density determining a parameter sensitive to stress in the ligaments, and from any variation of the said parameter as measured adjacent to different ligaments detecting if any ligamentous have broken or are over-stressed, wherein the alternating magnetic field is induced at at least two different frequencies at every measurement location, and the said parameter is determined from the values of flux density detected at those different frequencies.

Preferably a lower frequency is selected so as to provide a skin depth in the steel that is between an eighth of and twice the thickness of a wire or ligament. More preferably a lower frequency provides a skin depth substantially equal to a quarter of the thickness of a wire or ligament. Preferably a higher frequency is between 2 and 8 times greater than a lower frequency, more preferably between 3 and 5 times greater, and most preferably about 4 times greater; this latter case provides a skin depth half the previous value.

Measurements taken at different frequencies enable variations in the number of wires or ligaments in the vicinity of a probe to be distinguished from variations in the stress in the wires or ligaments. Measurements may be taken adjacent to different ligaments either by using an array of such probes adjacent to different ligaments,

- 3 -

or using a single such probe and scanning it circumferentially or longitudinally so that it passes adjacent to the ligaments in succession.

5 Preferably the magnetic field is in a direction that is not parallel to the longitudinal axes of the ligaments. With some steels, in which longitudinal stress has a significant effect of the transverse magnetic permeability, the magnetic field is preferably
10 in a direction perpendicular to the ligaments; with other steels the magnetic field is preferably in a direction between 30° and 60°, more preferably about 45°, to the direction of the ligaments. The magnetic field should be less than 0.9 times the value required for saturation,
15 preferably less than 0.5 times and more preferably less than 0.2 times, for example 0.15 or 0.10 times that value.

Flexible risers include a helically-wound steel wire
20 layer to provide tensile strength near the outer surface of the riser, and may in fact include two such steel wire layers. The failure mode typically involves fatigue fracture of one of the outer steel reinforcing wires or ligaments. When a wire fails in this way, the remaining
25 intact wires must take the extra load, and therefore their total stress increases. By arranging an array of electromagnetic stress sensing probes around the circumference of the riser or scanning such a probe around the circumference, the failure of one or more
30 wires or ligaments will result in a variation of the measured stress around the circumference. An increase in stress in one region indicates the failure of a ligament in a nearby region, or at least an impending failure where a fatigue crack has propagated through a
35 significant proportion of the cross-section of a ligament.

- 4 -

The preferred stress-measurement method involves resolving signals from the sensor that monitors the alternating magnetic flux density into an in-phase component and a quadrature component; and hence deducing
5 a stress-dependent parameter which is substantially unaffected by lift-off. This requires a preliminary calibration, with a specimen of the material, to determine how the in-phase and quadrature components of the signal vary with lift-off (at a constant stress). For
10 example the stress-dependent parameter may be calculated by resolving the signals from the sensor in a direction orthogonal to the lift-off line in the impedance plane.

Preferably the measurements are made using an
15 electromagnetic probe incorporating an electromagnet coil to induce the alternating magnetic field, the coil being wound onto an electromagnet core, the probe also incorporating one or more sensors to monitor the magnetic flux density near the cylindrical surface. One such
20 magnetic sensor may be arranged to sense the reluctance (or flux-linkage) of that part of the magnetic circuit between the poles of the electromagnet. Alternatively the magnetic sensor may be a flux-leakage sensor between the poles arranged to sense magnetic flux density just above
25 the cylindrical surface in a direction parallel to the free space magnetic field. This second sensor detects flux leakage, which is influenced by changes in material properties, lift-off, and cracks. Another type of sensor has its axis perpendicular to the surface of the riser
30 (or other structure), and may be a flat coil such as a pancake winding. This type of sensor detects components of leakage flux in radial directions, giving signals of opposite polarity at each side of a ligament, and so enables the positions of the ligaments or wires to be
35 detected, but surprisingly its signals are also dependant on stress.

- 5 -

Thus the method enables failure or over-stressing of a ligament or wire to be detected, and also provides some spatial resolution as to the location of the failure. Greater resolution can be obtained by using smaller probes, but smaller probes are more affected by lift-off from the surface. A preferred arrangement uses probes that are of width between 30 mm and 90 mm, preferably about 60 mm, as such probes are not excessively affected by lift-off and nevertheless provide adequate spatial resolution. When dealing with risers, the probe may be separated from the outermost ligaments by a considerable thickness of non-magnetic material (for example a polymer layer), and in this case a larger probe provides a greater signal to noise ratio, that is to say the signal variations arising from changes in stress are proportionately larger. However a larger probe, if monitoring flux linkage, will monitor a larger number of ligaments, so the sensitivity to a break of a single ligament is reduced. Hence in this context there may be benefits from using a larger probe, for example of width up to say 150 mm, for example 110 mm wide. It will also be appreciated that the face of the probe against the surface may be of any convenient shape, for example square or rectangular. Indeed, it may be feasible to operate with an electromagnet whose poles are separated by up to half the circumference of the riser. Particularly with a large electromagnet it may be appropriate to use flux leakage or pancake sensors, rather than flux linkage sensors, as these can be small enough to provide the necessary resolution.

The flux measurement signal from the or each probe may be backed-off, i.e. processed by first subtracting a signal equal to the signal from that sensor with the probe adjacent to a stress-free location. The backed-off

- 6 -

signal is then amplified so the small changes due to stress are easier to detect. This backing off is performed after resolving into in-phase and quadrature components but before deducing the stress-dependent
5 parameter. Preferably the signals from the or each probe are digitized initially, and the backing-off and resolution are performed by analysis of the digital signals.

When dealing with a flexible riser, or a similar
10 structure, the stresses in the wires or ligaments are almost exclusively along their lengths. It is also very difficult to obtain meaningful measurements by applying the alternating magnetic field parallel to the wires, because this generates eddy currents which flow around
15 the circumference of the individual wires, which overwhelm any effect due to changes in magnetic permeability.

The invention will now be further and more
20 particularly described, by way of example only, and with reference to the accompanying drawings, in which:

Figure 1 shows a perspective cut-away view of part
of a riser, to show its internal structure;

25

Figure 2 shows an end view of a probe array for monitoring a riser as shown in figure 1, by making measurements of stress;

30 Figure 3 shows a longitudinal sectional view of a probe for use in the array of figure 2;

Figure 4 shows graphically measurements made on a riser as shown in figure 1 using a probe as shown in
35 figure 3, in which a broken wire is evident; and

- 7 -

Figures 5a to 5c show measurements made with a probe as shown in figure 3, but with three different types of sensor.

5 Referring to figure 1, a flexible riser 10, which acts as a hose to carry a pressurised fluid, has several concentric layers. An innermost layer 12 of helically wound bent steel strip provides resistance against external pressures, and a similar helically wound steel
10 strip layer 14 provides hoop strength, and between these layers is a fluid barrier layer 16 of polymeric material. These are surrounded by two layers 18 and 20 of helically-wound steel ligaments or wires to provide tensile strength, separated from the steel strip layer 14
15 and from each other by respective anti-wear layers 17 and 19. A polymeric layer 22 provides an external sleeve and fluid barrier. As discussed above, the failure mode with such a riser 10 is typically the failure of one or more
20 ligaments in the outermost layer 20. But it will be appreciated that these ligaments cannot be observed directly, because they are enclosed within the outer layer 22.

Referring now to figure 2, the stresses in the
25 outermost layer 20 of steel ligaments of a riser 10 as shown in figure 1 may be monitored using an array of electromagnetic stress-measuring probes 24 in an annular frame 25. The frame 25 is in two generally semicircular halves which are hinged together at a pivot pin 26 and
30 locked into an annular form by a securing pin 28. Hence in use the frame 25 can be clamped so as to surround the riser 10, there being a clearance of no more than 2 mm between the inside of the frame 25 and the outer surface of the riser 10. The frame 25 is shown as carrying only
35 six electromagnetic probes 24, although it will be appreciated that it might support a different number, and

- 8 -

indeed it would be preferable to have the separation between adjacent probes 24 similar to the width of each probe 24. (If probes are close to each other, they should not be energised at the same time.) If greater
5 spatial resolution is required, there might be a second such array of probes 24 axially displaced and staggered in position relative to those shown.

Alternatively the stresses might be monitored using
10 a single such probe 24 that is scanned around the circumference, measurements being taken at a multiplicity of successive locations.

Referring now to figure 3, each probe 24 includes a
15 U-core 32 of silicon iron which defines two rectangular poles 34 in a common plane, each pole being 60 mm by 12 mm, and the space between the poles being 60 mm by 36 mm. The faces of the poles 34 are slightly curved to match the curvature of the outer surface of the riser 10.
20 Around the upper end of the U-core 32 is a former on which are wound two superimposed coils 36 and 36a. One coil 36 has 145 turns, and in use is supplied with an AC current of 0.6 A; this is the energising coil 36. When energized, this generates an alternating magnetic field
25 in the U-core 32 and in the adjacent helically-wound steel ligaments of the layer 20 in the riser 10, this magnetic field being small compared to the saturation field for the steel. The orientation of the probes 24 is such that the free space magnetic field is in a direction
30 at 90° to the orientation of the steel ligaments in the layer 20. The other coil 36a is a sensing coil which provides the reluctance signals.

The probes 24 may also include other magnetic
35 sensors, for example there may be a coil 40 between the poles whose longitudinal axis is parallel to the free-

- 9 -

space magnetic field direction, supported on a non-magnetic plate 38 fixed between the arms of the U-core 32. This coil 40 detects leakage flux. The signals from the sensing coil 36a and from the leakage flux coil 40 (if provided) are amplified by a head amplifier before further processing.

In operation, with the probes 24 clamped around the riser 10, the alternating current is supplied to the drive coils 36. The in-phase and quadrature components of the flux linkage signal (i.e. the component in phase with the drive current, and the component differing in phase by 90°) received from the sensing coil 36a are each backed off to zero, and the backing off values are then fixed. During all subsequent measurements the flux linkage components are backed off by these same amounts (i.e. subtracting a signal equal to the component observed at a stress-free location or at any rate a location of uniform stress). Preferably the signals are digitised before backing off.

A parameter indicative of the stress in the layer in the longitudinal direction can be determined from the experimental measurements of flux linkage, once the measurements have been compensated for lift-off. This requires calibration of the probe 24. As explained in WO 03/034054, such a compensation may be carried out graphically, the backed-off in-phase and quadrature components of the reluctance signal from the coil 36a being plotted on a graph, measurements being obtained first with varying lift-off and then with varying stress. Alternatively such corrections may be carried out algebraically for example as described in WO 2005/001466. However in the present situation it is only necessary to compensate for any changes in lift-off, and this can be achieved by a calibration using one such probe 24, taking

- 10 -

measurements at progressively larger values of lift-off from the surface of the riser 10. This gives a changing-lift-off contour in the impedance plane.

5 Subsequently, measurements can be compensated for lift-off by determining the component in the direction orthogonal (in the impedance plane) to the direction of the changing-lift-off contour. This orthogonal component is the output parameter, and is dependent upon stress.

10

In this example the ligaments in the layer 20 are rectangular in cross-section, each 4 mm thick and 12 mm wide. Measurements are made with each probe 24 in the array (or with a single probe 24 that is scanned around
15 the circumference), at any one position measurements being taken at 70 Hz and then at 280 Hz. These measurements might for example be taken successively within 1 s of each other (so that the ligaments will not have moved between the measurements), preferably within
20 0.3 s of each other, for example after 0.2 s. At 70 Hz the skin depth in steel is about 1.2 mm. The value of the output parameter obtained at 70 Hz is dependent upon the stress in the wires, but is also affected by the number of wires in the immediate vicinity of the probe 24, and
25 this number will not only vary between different locations around the circumference, but will also vary as the longitudinal stress in the riser 10 varies. At 280 Hz the skin depth is only about 0.6 mm, and the value of the output parameter is primarily determined by the
30 number of ligaments in the immediate vicinity of the probe 24. By comparing the values of the output parameter at at least two different frequencies, the variations in the number of ligaments can be eliminated, so providing a corrected output parameter dependent only
35 on the stress in the ligaments.

- 11 -

The two values are preferably normalised so that with unstressed (or uniformly stressed) ligaments the values are equal; then the difference between the normalised values may be taken as the corrected output value, P. The appropriate amplification for normalisation can be determined by scanning a section of riser at the one frequency, and then at the other; this produces signals which display peaks and troughs (caused by the geometrical arrangement of the ligaments), and the two signals are scaled so that they have equal ranges between peaks and troughs, that is to say equal sensitivity to ligament separations; they may also be adjusted so that the signals in each case range between the same values (say 0 and 1). In the latter case, the ratio between the two normalised values of the output parameter at these two different frequencies might instead be taken as the output value.

Referring now to figure 4 there is shown graphically the corrected output parameter P obtained in this way using a single probe scanned around the circumference of a riser, in which one ligament had been cut, in an experimental setup in which the riser was subjected to internal hydrostatic pressure so that the ligaments are under longitudinal stress. In this case the signals had been normalised with an unstressed riser, and the output parameter P is the difference between the normalised values. It can be seen that for most of the circumference the output parameter is small and positive (indicating the longitudinal stress), but at the position marked X one of the ligaments is clearly under a markedly smaller stress than the others. This is indicative of there being a cut in that ligament.

Referring now to figure 5 the experimental results are shown for measurements made scanning a single probe

- 12 -

longitudinally along a section of riser subjected to a longitudinal stress, in which three adjacent ligaments in the outer layer were cut at a position 103 mm from the end. Measurements were made using three different sensor coils: a flux linkage sensing coil 36a, a flux leakage-sensing coil 40, and a flat "pancake" coil (not shown) whose axis is perpendicular to the surface of the riser. In each case the probe was arranged with the magnetic field direction approximately at right angles to the orientation of the ligaments in the outer layer, and the signals measured at each frequency, after being corrected for liftoff as described above, were normalised to provide equal values for ligament separation sensitivity, and the difference between the normalised signals at the two frequencies was taken as the stress parameter, P. The measurements were taken as the probe was scanned along the section of riser, starting at about 700 mm and ending up at about 3800 mm from the end. Because the ligaments are wound helically, the probe crosses over the cut ligaments at intervals of about 880 mm.

Figure 5a shows the variation in the stress parameter P1 measured using the flux linkage sensing coil 36a. It will be observed that the stress parameter P1 provides a large negative signal on the three occasions that the probe passes over the cut ligaments. The magnitude of the peak decreases slightly between the first and second occasions that the probe passes over the ligaments, but it is clear that even at a distance of over 3 m from the position of the cut, the peak indicating decreased stress is clearly distinguishable from the background variation between other ligaments.

Figure 5b shows the variation in the stress parameter P2 measured using the flux leakage sensing coil

- 13 -

40. In this case the stress parameter P2 provides a large positive signal whenever the probe passes over the ligaments that had been cut. The magnitude of the peak decreases with distance from the position of the cut.

5

Figure 5c shows the variation in the stress parameter P3 measured using the flat "pancake" coil. In this case the stress parameter P3 is zero as the probe is directly above the ligaments that have been cut, but
10 provides a large positive signal just before the cut ligaments and a large negative signal just after the cut ligaments. Again the magnitude of the peaks decreases slightly with distance from the position of the cut, but as with the other sensors, the peak is clearly
15 distinguishable from background variations even at over 3 m from the position of the cut. These measurements suggest that the cut ligaments could be detected at a distance of some metres, possibly as far as 10 m.

20 With a riser 10, a break in a ligament within the outer layer 20 locally reduces the stress in that ligament to near zero and slightly increases the stresses in all the other ligaments. Over a length of several metres the resulting non-uniformities in stress even out,
25 as stresses are transmitted between adjacent ligaments. However, it has been found that such a break in a steel ligament almost always occurs near an end of the riser 10, within the connection to an end-fitting. Hence as long as the probe 24 (or the array of probes 24) is
30 arranged to monitor stresses within a few metres of an end of the riser, the ligament failure can be detected from the consequential stress differences. The measurements are preferably made no more than 6 m from the end-fitting, and more preferably no more than 4 m
35 from the end-fitting.

From the description above it will be appreciated

- 14 -

that when inspecting a riser that incorporates smaller wires or ligaments, it would be appropriate to use higher frequencies, so that the skin depth is matched to the size of the wires. For example if the riser contained an
5 outer layer of wires of diameter 2 mm, then suitable frequencies would be four times greater, i.e. 280 Hz and 1120 Hz. It will also be appreciated that these frequencies are given by way of example only, and that the inspection might use somewhat different frequencies,
10 for example 250 Hz and 1200 Hz, as the higher frequency might be a different multiple of the lower frequency.

An inspection apparatus as described in relation to figure 2 might for example be installed on a riser in the
15 vicinity of an end-fitting to monitor for any breaks in the ligaments, and may be installed temporarily (to carry out occasional inspections) or permanently. Alternatively it might be scanned along the length of a hose or riser, so that failure of wires along the entire length can be
20 detected; if a localised area of increased stress is detected, this may be due to a failure in the inner hoop windings 12.

- 15 -

Claims

1. A method for monitoring a flexible elongate structure with a generally cylindrical surface, the structure
5 comprising at least one layer of steel ligaments near the cylindrical surface, the steel ligaments extending at least partly along the length of the structure, the method comprising inducing an alternating magnetic field less than saturation in the steel ligaments using an
10 electromagnet with spaced-apart poles adjacent to the cylindrical surface, and monitoring the alternating magnetic flux density near the said cylindrical surface in the vicinity of the said electromagnet, from the detected flux density determining a parameter sensitive
15 to stress in the ligaments, and from any variation of the said parameter as measured adjacent to different ligaments detecting if any ligaments have broken, wherein the alternating magnetic field is induced at at least two different frequencies at every measurement location, and
20 the said parameter is determined from the values of flux density detected at those different frequencies.

2. A method as claimed in claim 1 wherein a lower frequency is selected so as to provide a skin depth in
25 the steel of the ligaments that is between an eighth of and twice the thickness of a ligament.

3. A method as claimed in claim 2 wherein the lower frequency provides a skin depth substantially equal to a
30 quarter of the thickness of a ligament.

4. A method as claimed in any one of the preceding claims wherein a higher frequency is at least twice a lower frequency.

35

5. A method as claimed in claim 4 wherein the higher

- 16 -

frequency is between 3 and 5 times greater than the lower frequency.

6. A method as claimed in any one of the preceding claims
5 wherein the magnetic field is in a direction that is not parallel to the longitudinal axes of the ligaments.

7. A method as claimed in any one of the preceding
10 claims wherein the measurements are made using an electromagnetic probe incorporating an electromagnet coil to induce the alternating magnetic field, the coil being wound onto an electromagnet core, the probe also incorporating one or more sensors to monitor the magnetic flux density near the cylindrical surface.

15

8. A method as claimed in any one of the preceding
claims wherein signals from the sensor that monitors the alternating magnetic flux density are resolved into an in-phase component and a quadrature component, from which
20 a stress-dependent parameter which is substantially unaffected by lift-off is determined.

9. A method as claimed in claim 8 wherein a stress-
dependent parameter is calculated by resolving the
25 signals from the sensor in a direction orthogonal to the lift-off line in the impedance plane at each of the frequencies, and comparing the resolved signals.

10. A method as claimed in claim 9 wherein the resolved
30 signals are normalised, and then the difference between the normalised values is taken as the stress-dependent parameter.

11. A method as claimed in any one of the preceding
35 claims, the method using an array of probes in an annular support frame around the circumference of the riser.

1/3

Fig.1.

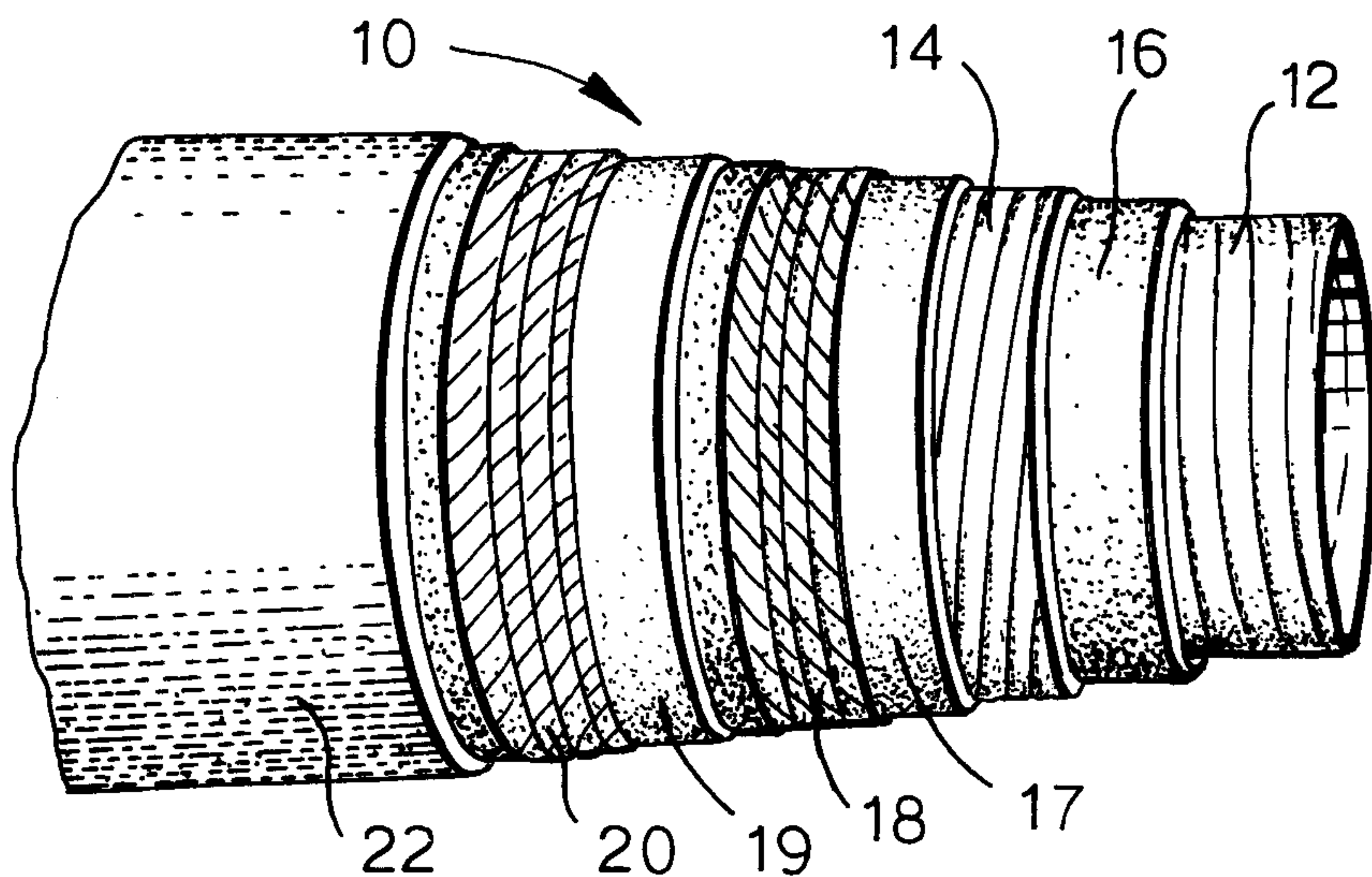

Fig.2.

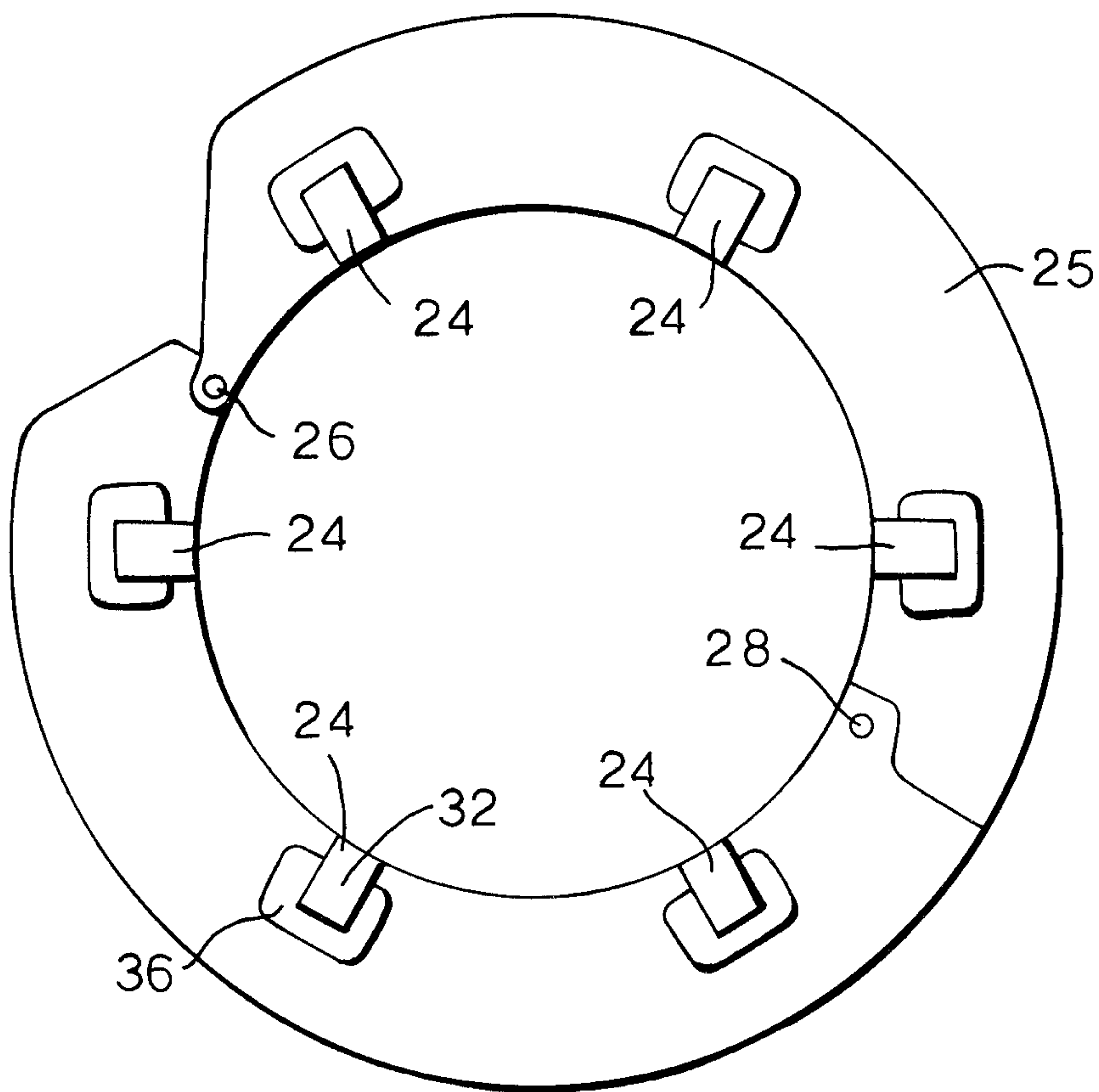
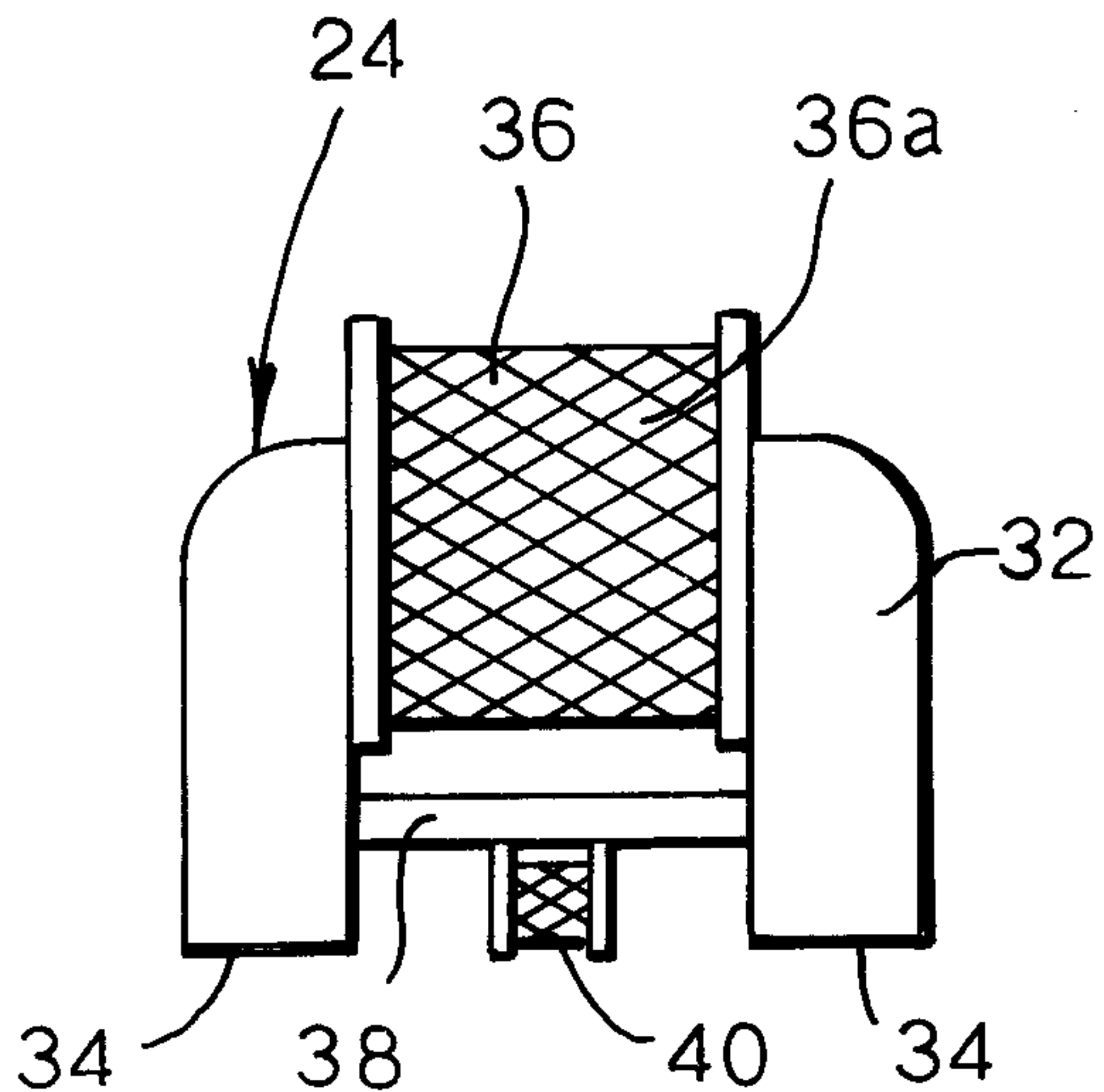
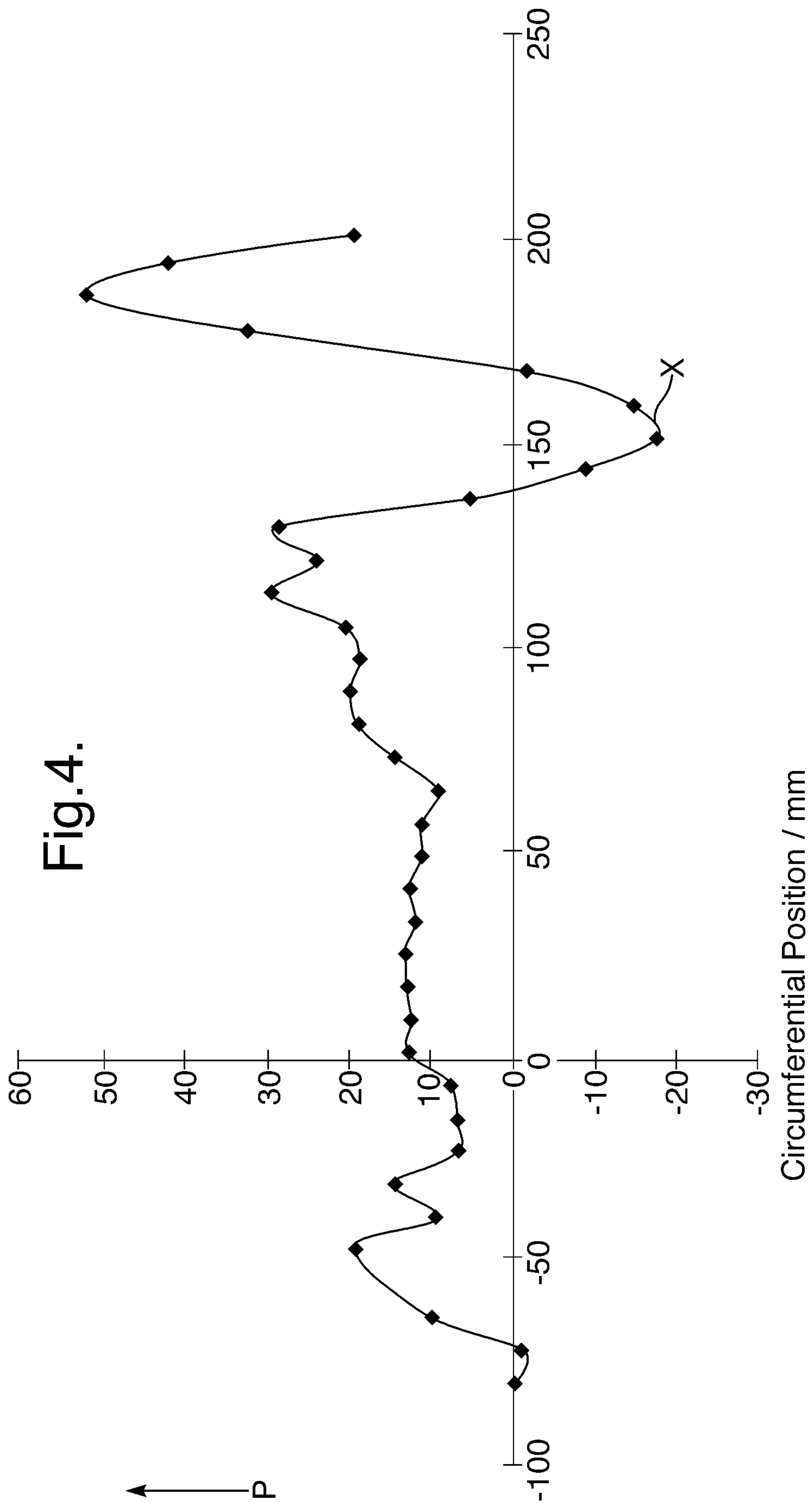

Fig.3.



2/3



3/3

Fig.5a.

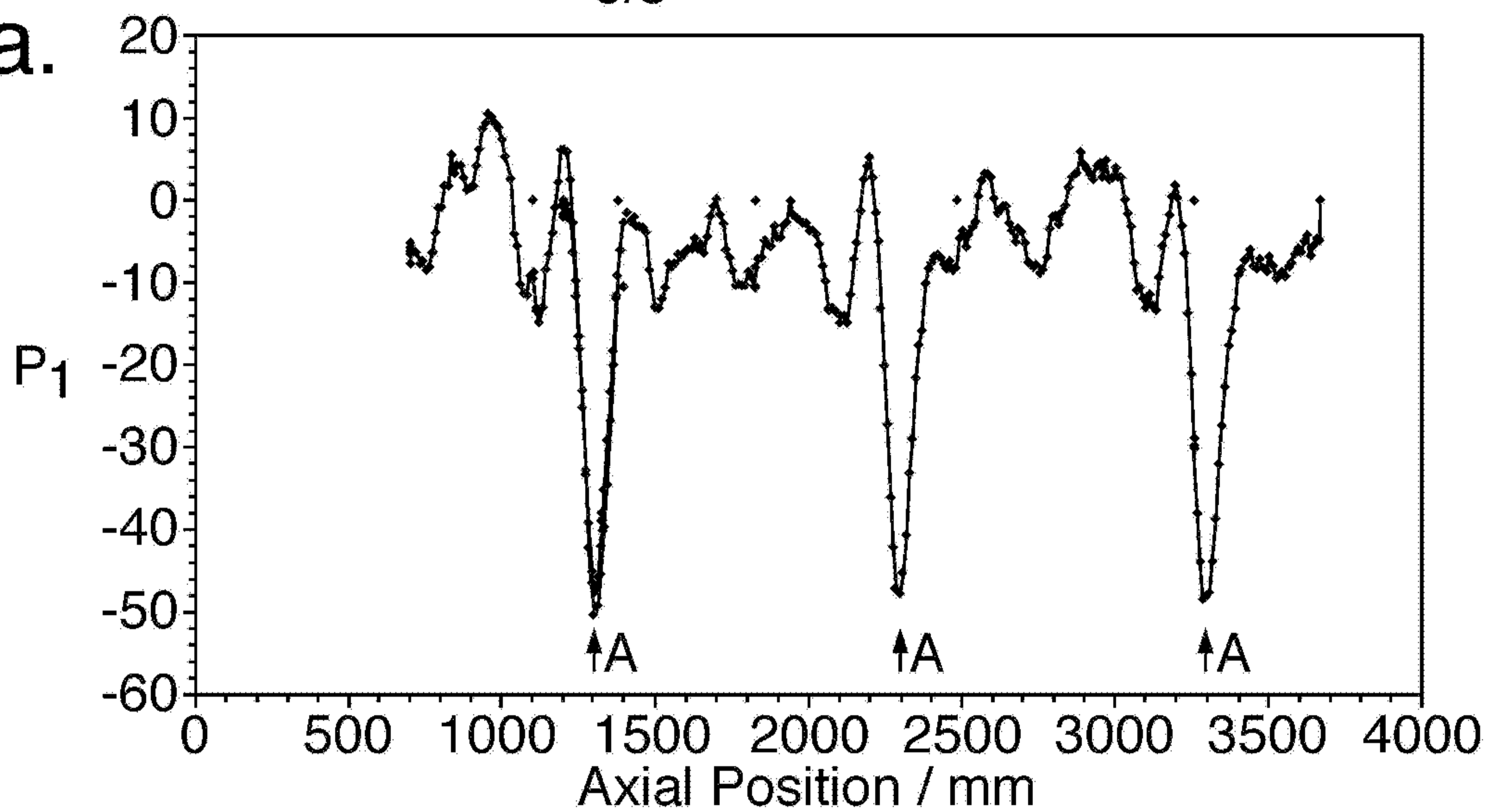

Fig.5b.

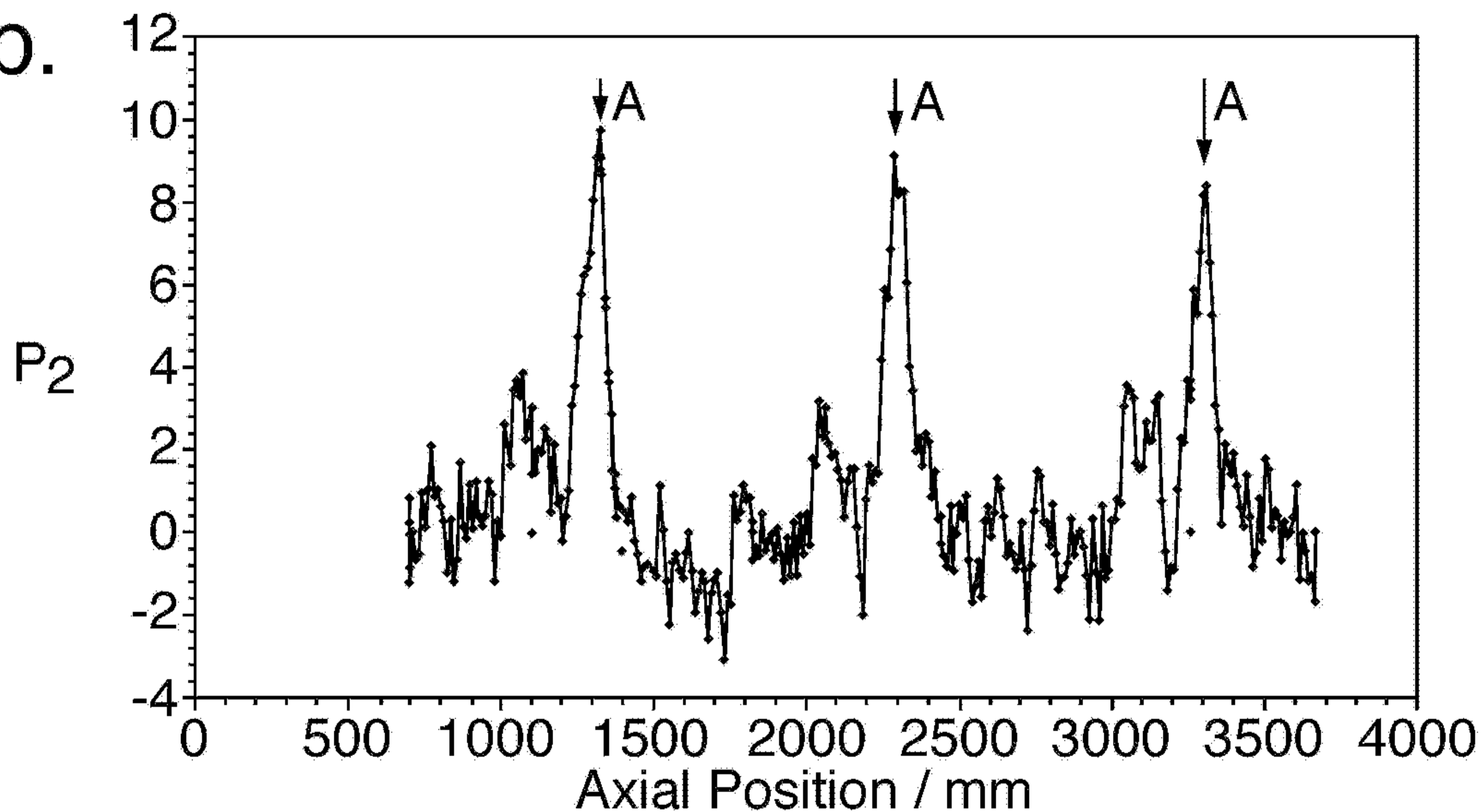

Fig.5c.

