

No. 639,701.

Patented Dec. 26, 1899.

**A. BASENER.  
CHILLER GRINDER.**

(Application filed Aug. 12, 1899.)

(No Model.)

*FIG. 1*

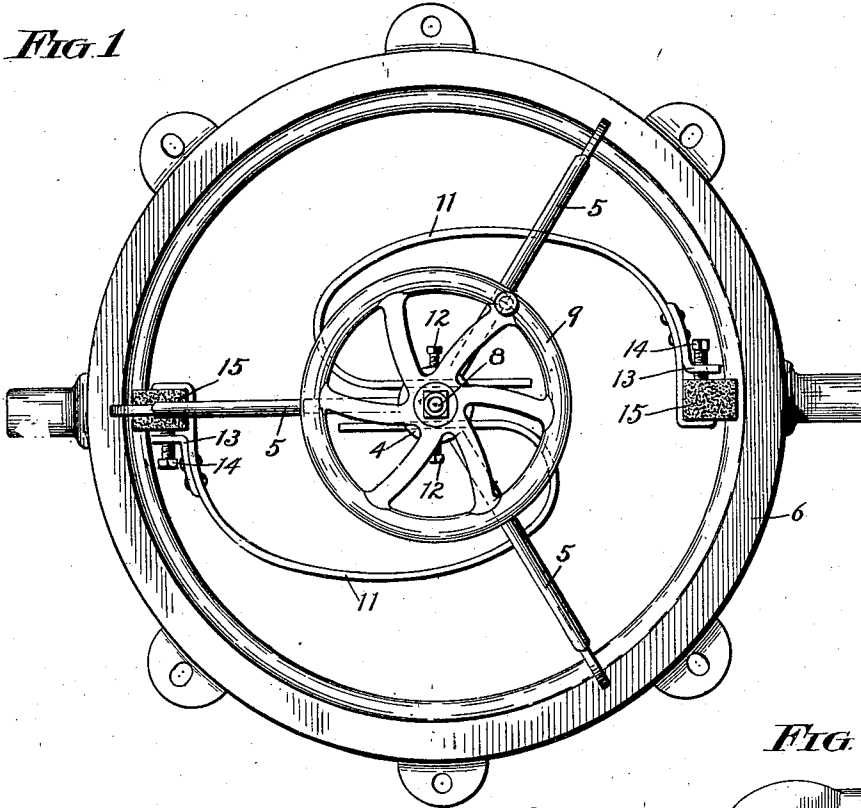

*FIG. 2*

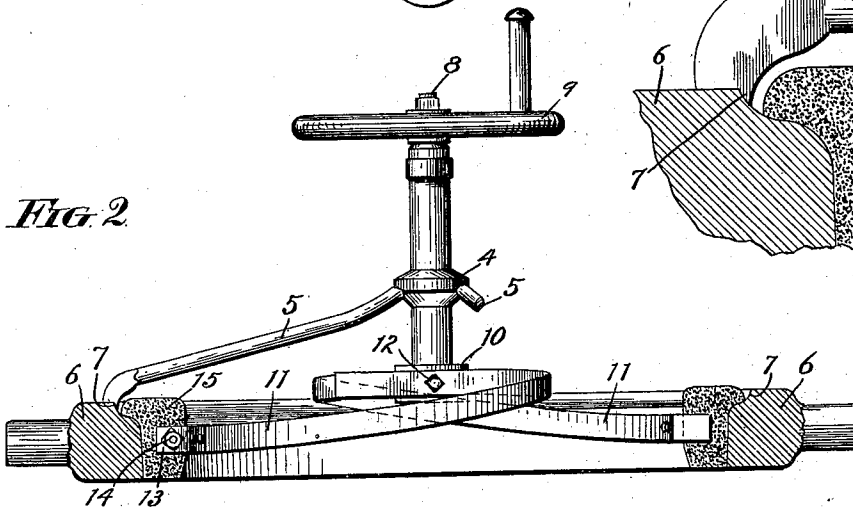

*FIG. 3*

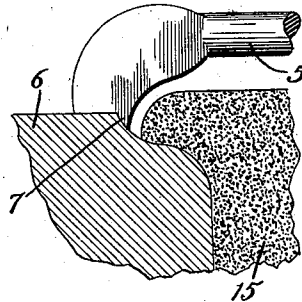

*Witnesses:*  
*Ira D. Perry,*  
*J. B. Weir,*

*Inventor:*  
*Anselm Basener*  
*by atty.*  
*Paul Synnestvedt*

# UNITED STATES PATENT OFFICE.

ANSELM BASENER, OF CHICAGO, ILLINOIS, ASSIGNOR TO THE GRIFFIN WHEEL COMPANY, OF SAME PLACE.

## CHILLER-GRINDER.

SPECIFICATION forming part of Letters Patent No. 639,701, dated December 26, 1899.

Application filed August 12, 1899. Serial No. 727,007. (No model.)

*To all whom it may concern:*

Be it known that I, ANSELM BASENER, a citizen of the United States, residing in Chicago, Cook county, Illinois, have invented a new and useful Improvement in Chiller-Grinders, of which the following, taken in connection with the accompanying drawings, is a specification.

My invention has for its object the improvement of that type of chiller-grinders which employs, in combination with a chiller-ring, a frame adjacent thereto carrying a plurality of arms revolubly mounted in the frame, grinding-pieces carried by the arms, and means for yieldingly holding the grinding-pieces against the inner face of the chiller-ring.

More specifically, my invention has for its object the construction of a chiller-grinder of the type above described, in which the frame shall be mounted upon and centered by the chiller instead of as has been heretofore the practice having it mounted upon the cope. In the use of such prior construction some difficulty has been encountered in any case where the cope and the chiller-ring happened to be a little out of center, because in such case the yielding force holding the grinding-pieces against the inner face of the chiller-ring would be greater at one part of the ring than at another, resulting in an uneven grinding effect, besides causing the machine to work harder.

Another object of my invention is the provision of long spiral spring-arms in the place of the rigid ones heretofore used, which had sockets for the projecting grinders and employed coiled springs mounted in recesses within the rigid arms. By this improved construction I find more satisfactory results can be obtained, because there is secured thereby a more even pressure upon the grinding-pieces and the arms can be more readily provided with adjustable devices such as are necessary to compensate for wear of the grinding-pieces and to change the apparatus for different sizes of chiller-ring.

The above, as well as such other objects as may hereinafter appear, I attain by means of a construction which I have illustrated in preferred form in the accompanying drawings, in which—

Figure 1 is a plan view showing a chiller-

ring with my improved grinder applied thereto. Fig. 2 is a side elevation, partly in section, of the same; and Fig. 3 is an enlarged view showing the manner in which the supporting-arms which carry the frame are mounted upon the chiller-ring.

In the construction of my improved grinder I provide, first, a frame 4, having three supporting-arms 5, extending out to a point over the chiller-ring 6 and by the projecting finger 7 engaging that part of the ring which forms the flange of the wheel. (See Fig. 3.) Within the frame 4 is a revoluble shaft 8, carrying an operating hand-wheel 9 upon its upper end. At the lower end of the shaft 8 is secured a block 10, to which are attached two spring-arms 11, the same being secured adjustably in position by means of the set-screws 12 in a manner which will be clearly shown on an examination of the drawings, especially Fig. 1 thereof. Upon the outer ends of the spring-arms 11 I provide a forked projection 13, within which, by means of the set-screws 14, I secure a couple of grinding-pieces 15, made to fit the inner face of the chiller-ring.

The operation of my invention is as follows: The frame having been properly mounted upon the chiller-ring, the grinding-pieces are inserted in place and the arms 11 adjusted by means of the set-screws 12, so as to have just the proper amount of pressure against the inner face of the chiller-ring. The operator then by rotation of the wheel 9 causes the grinding-pieces to travel around upon the inside face of the chiller-ring and grind off the uneven ridges or projections which are formed by the fire-cracks produced from the action of the heat. The tension of the arms 11 is adjusted so that it is sufficient to cause the grinding-pieces to rapidly dress off the objectionable projections or ridges, but not to have any appreciable effect in wearing or grinding the inner face of the ring itself during the operation.

Having thus described my invention, what I claim as new, and desire to secure by Letters Patent, is—

1. A chiller-grinder comprising the combination with a chiller-ring of a frame adjacent thereto, means for mounting said frame upon

said chiller-ring, a plurality of arms revolubly mounted in said frame, grinding-pieces carried by said arms, means for yieldingly holding said grinding-pieces against the inner face of said chiller-ring, and means for revolving said arms.

2. A chiller-grinder comprising the combination with a chiller-ring of a frame adjacent thereto, a plurality of spring-arms revolubly mounted in said frame, grinding-pieces carried by said arms and yieldingly held thereby against the inner face of said chiller-ring, and means for revolving said arms.

3. A chiller-grinder comprising the combination with a chiller-ring of a frame adjacent

thereto, a plurality of arms whereby said frame is supported upon said ring, projections upon said arms engaging that portion of the ring which contacts with the flange of the casting whereby to hold said frame in central position relative to said chiller-ring, a plurality of arms revolubly mounted in said frame, grinding-pieces carried by said arms, means for yieldingly holding said grinding-pieces against the inner face of said chiller-ring, and means for revolving said arms.

ANSELM BASENER.

Witnesses:

PAUL CARPENTER,  
E. M. KATCHER.