

June 17, 1924.

1,497,982

P. H. MA GIRL

WARM AIR HEATER

Filed Jan. 11, 1923

4 Sheets-Sheet 1

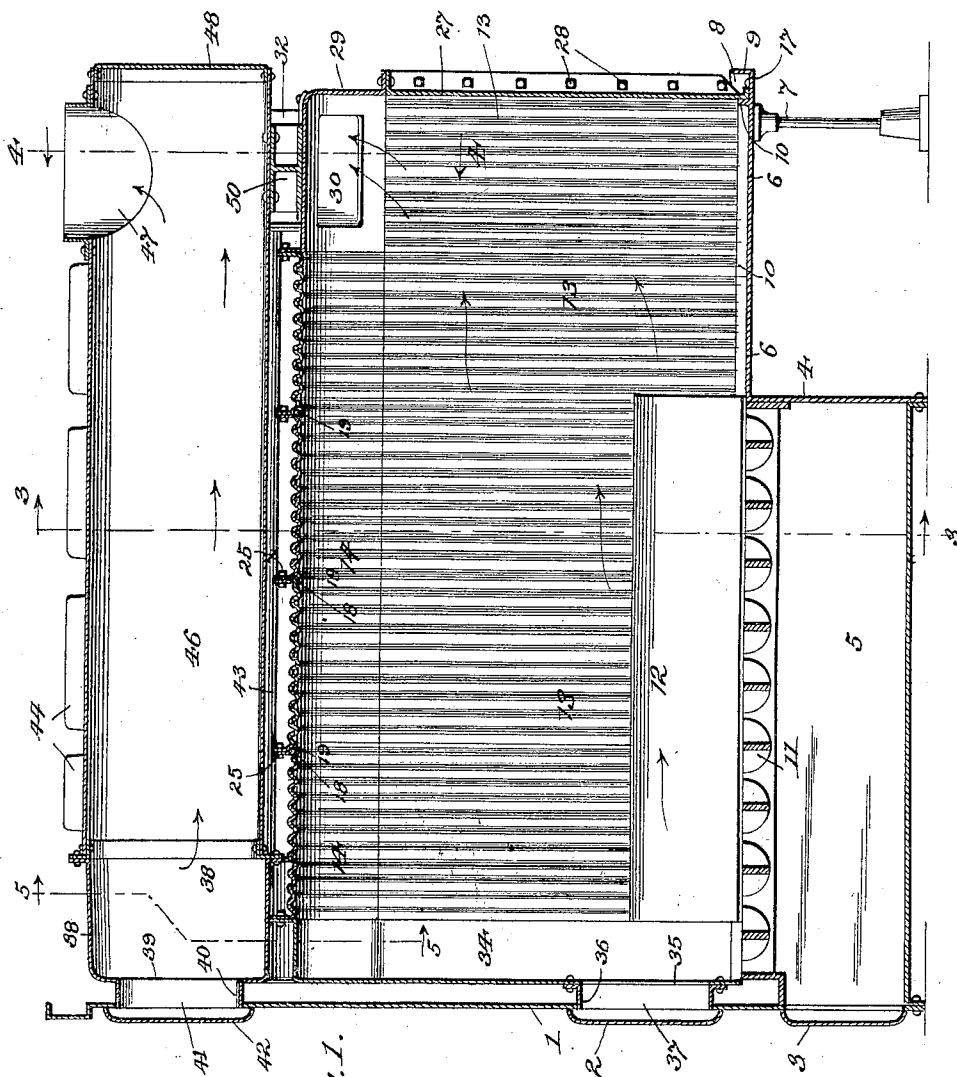

Fig. 1.

Inventor
Patrick H. McGill, Deceased
James D. McGill,
Ida E. Dalton,
Gertrude A. Johnston
Executors,

By *Rodge & Sons* Attorneys.

June 17, 1924.

P. H. MA GIRL
WARM AIR HEATER

1,497,982

Filed Jan. 11, 1923

4 Sheets-Sheet 2

Fig. 2.

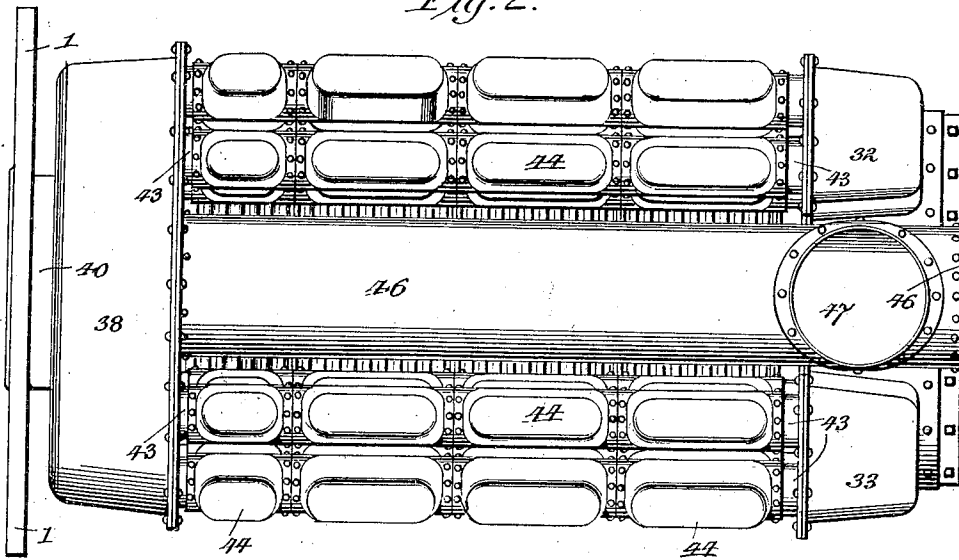

Fig. 4.

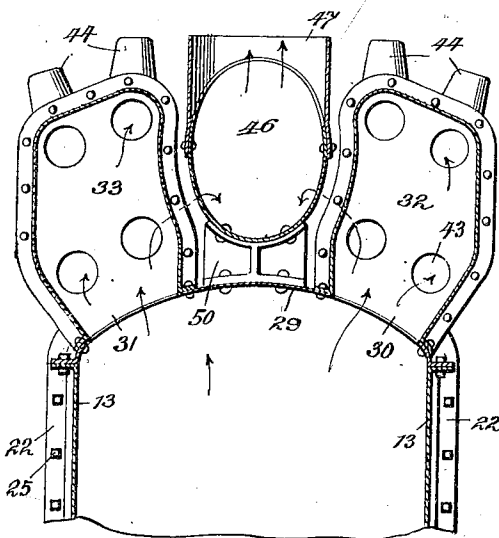
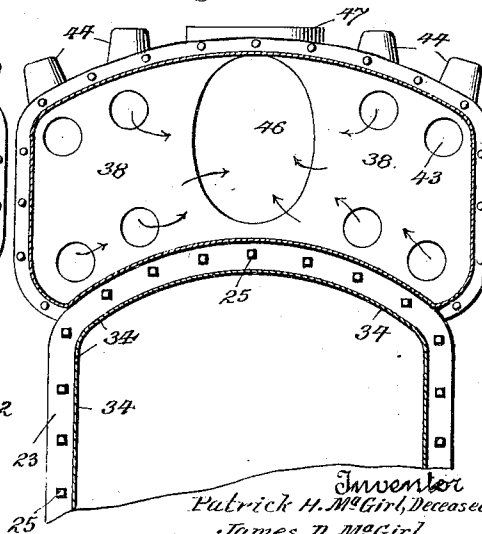

Fig. 5.



Inventor
Patrick H. McGirl, Deceased,
James D. McGirl,
Ida E. Dalton,
Gertrude H. Johnston,
Executors,
By *Dodys and Sons* Attorneys.

June 17, 1924.

1,497,982

P. H. MA GIRL

WARM AIR HEATER

Filed Jan. 11, 1923

4 Sheets-Sheet 3

Fig. 3.

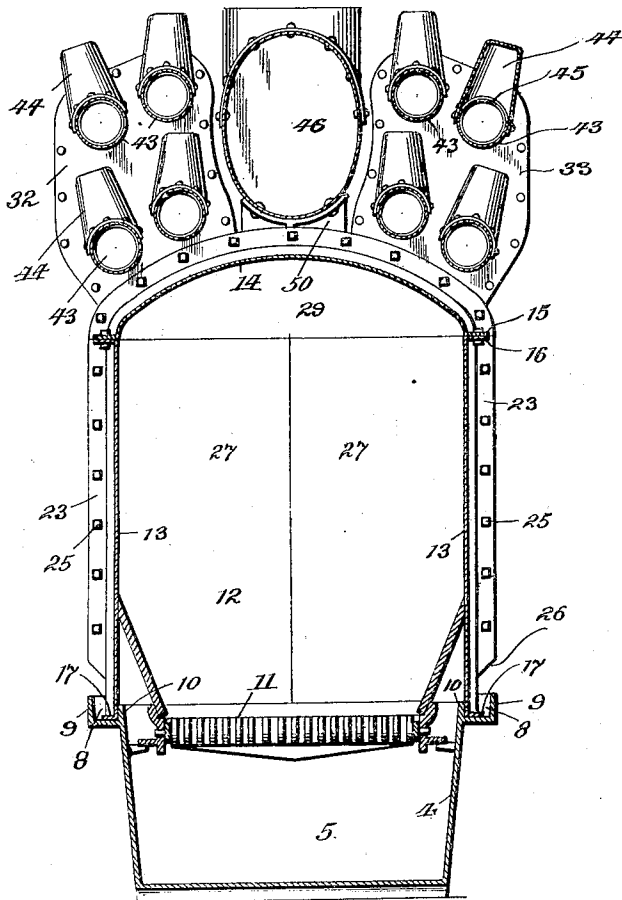

Inventor
Patrick H. McGill, Deceased,
James D. McGill,
Ida Dalton,
Gertrude H. Johnston,
Executors,
By *Dodys* *and* *Dino* Attorneys.

June 17, 1924.

1,497,982

P. H. MA GIRL
WARM AIR HEATER

Filed Jan. 11, 1923 . 4 Sheets-Sheet 4

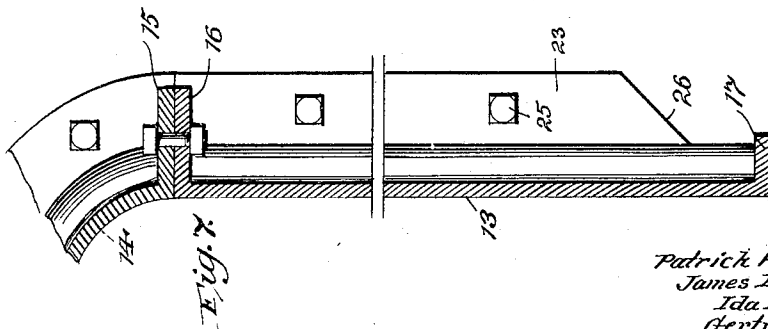
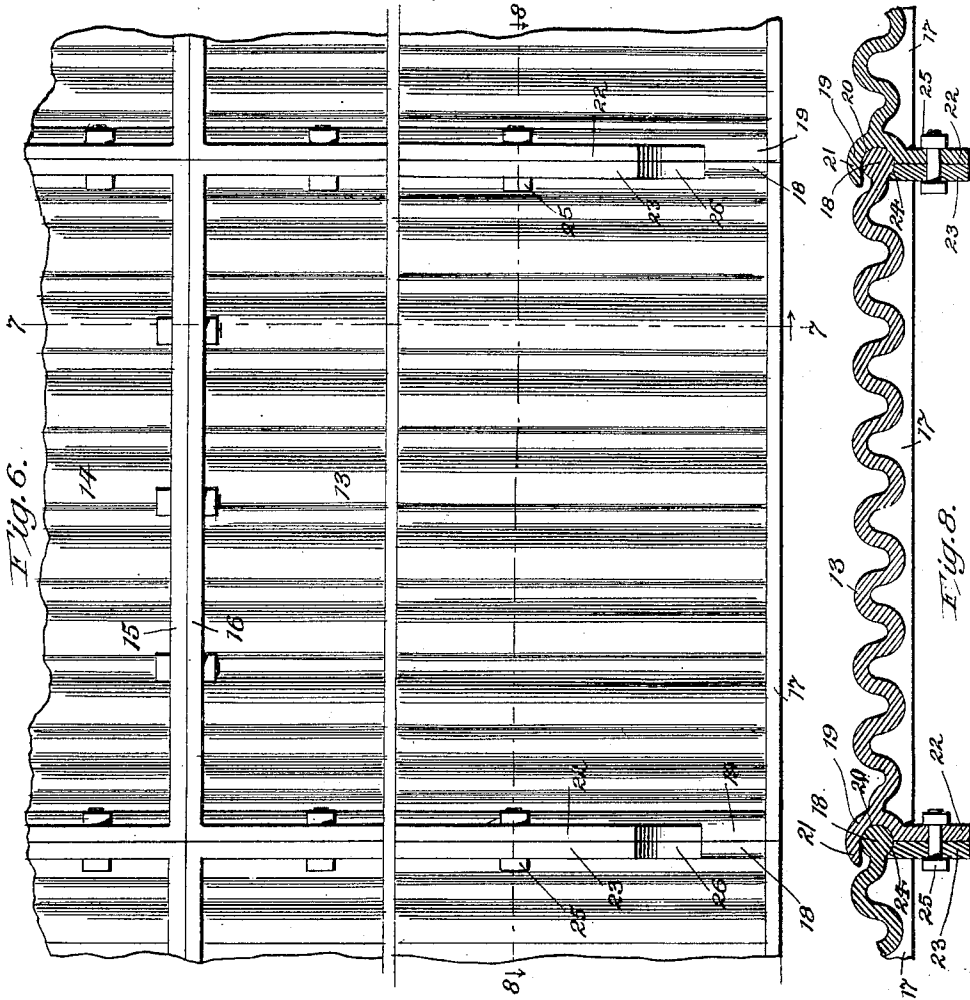

Inventor
Patrick H. McGill, Deceased,
James D. McGill,
Ida E. Dalton,
Gertrude A. Johnston,
Executors.
BY *Boyle and Moore* Attorneys.

UNITED STATES PATENT OFFICE.

PATRICK H. MA GIRL, DECEASED, LATE OF BLOOMINGTON, ILLINOIS; BY JAMES D. MA GIRL, IDA E. DALTON, AND GERTRUDE A. JOHNSTON, EXECUTORS, OF BLOOMINGTON, ILLINOIS.

WARM-AIR HEATER.

Application filed January 11, 1923. Serial No. 612,072.

To all whom it may concern:

Be it known that JAMES D. MA GIRL, IDA E. DALTON, and GERTRUDE A. JOHNSTON, citizens of the United States, and residents of Bloomington, in the county of McClean and State of Illinois, executors of the estate of Patrick H. Ma Girl, late a citizen of the United States, and a resident of Bloomington, in the county of McClean and State of Illinois, have knowledge that the said Patrick H. Ma Girl did invent certain new and useful Improvements in Warm-Air Heaters, of which the following is a specification.

This invention relates to warm air heaters and is intended to provide an improved construction over that covered by Letters Patent No. 1,163,676 issued to Patrick H. Ma Girl under date of December 14, 1915.

The more prominent features of novelty in the construction and operation of the present furnace, which contribute to a decided increase in efficiency over former heaters of this type, comprise fire-box sections provided with a special form of interlock for connecting the sections together so as to render the joints gas and dust-proof; the provision of self-cleaning pockets or recesses in the horizontal, heat-radiating flues or tubes which conduct the products of combustion from the rear breeching to the front breeching, the flow of the products of combustion being somewhat retarded by these pockets into and out of which a portion of the products pass to make use of the increased radiating surface furnished by the walls of the pockets; extensions on the front breeching and fire-box which pass freely through suitable openings therefor in the ornamental front of the furnace so as to permit expansion of the furnace without disturbing the ornamental front which is encased in masonry; and the arrangement of the back breechings directly over the rear of the fire-box and supported by the lower sections thereof, whereby the rear breechings present prime radiating surface to the fire at all times and are self-cleaning, the soot from the breechings falling into the fire-box.

The present heater is more particularly intended for installation in schools, churches, factories and other public buildings in one

or more units located in brick, asbestos-lined, sheet-metal or the like casings.

Other objects and advantages of the improved construction will be apparent from the following detailed description and the accompanying drawings in which the same numerals indicate like parts throughout the several views, and wherein—

Figure 1 represents a longitudinal vertical section taken centrally of the improved furnace;

Fig. 2, a plan view of the furnace;

Fig. 3, a vertical transverse section taken on line 3—3 of Fig. 1, looking towards the rear of the furnace;

Fig. 4, a vertical transverse section taken on line 4—4 of Fig. 1, looking towards the front of the furnace;

Fig. 5, a similar section taken on line 5—5 of Fig. 1, looking towards the rear of the furnace;

Fig. 6, an enlarged fragmentary side elevation showing the manner in which the fire-box sections are connected together;

Fig. 7, a vertical transverse section taken on line 7—7 of Fig. 6; and

Fig. 8, a horizontal section taken on line 8—8 of Fig. 6, looking downwardly, the joints between the fire-box sections being clearly shown.

It is intended that the present furnace structure be enclosed in the usual masonry casing which serves to confine the air to be heated and causes it to flow in contact with the fire-box and flues, and, as such casings are common in the art, it is unnecessary to illustrate this part of the completed heater.

The furnace structure includes the usual cast-iron front 1 provided with a fuel-door 2 and an ash-pit door 3. The casting 4, which forms the ash-pit 5, is bolted to the front 1 and, at its rear upper edge, is provided with an extension or shelf 6. Extension 6 together with the parts carried thereby is maintained in proper horizontal position by suitable adjustable supporting means engaging the outer end of the extension, as shown at 7, Fig. 1. The casting 4, forming ash-pit 5 and extension 6, is provided with a peripheral groove or channel 8 extending along the upper side and rear edges thereof, this channel being preferably formed by integral

upstanding flanges 9 and 10 provided on the casting. Suitably mounted in the upper part of the ash-pit 5 is the grate 11 above which is the fire-box 12.

5 The sides and most of the top of fire-box 12 are formed of flat sections 13 and arched sections 14 which are preferably corrugated in cross-section, as shown in Figs. 1 and 8, to increase their surface. The lower edges of the arched sections 14 are provided with perforated flanges 15 adapted to cooperate with similar flanges 16 provided on the upper edges of sections 13 for bolting the sections together, as shown in detail in Figs. 6 and 7. Outstanding flanges 17 are formed on the lower edges of sections 13 in order to reinforce them and provide a greater bearing surface for the sections which rest in channel 8 on the upper edges of casting 4, whereby the latter supports the entire fire-box structure. Flanges 17, however, are made sufficiently narrow so as to leave a clearance between the lower edges of sections 13 and the flanges 9 and 10 forming channel 8 to allow for expansion and contraction of the fire-box structure.

A specially designed joint is provided between the vertically abutting edges of the fire-box sections 13 and 14, in order to guard against any leakage of the products of combustion through the walls of the fire-box. This joint is shown most clearly in Figs. 6, 7 and 8. Each fire-box section 13 and 14 has formed along one vertical edge a continuous integral bead or enlargement 18, circular in cross-section as shown in Fig. 8. Each bead 18 is adapted to be received snugly by a corresponding continuous socket enlargement 19 integrally formed on the adjoining edge of the next fire-box section. Each enlargement 19 has a groove 20, semi-circular in cross-section, which receives bead 18, the maximum depth of this groove being substantially one-half the diameter of bead 18. Inside of fire-box 12, each socket enlargement 19 is formed with a continuous integral lip 21 projecting from one of the edges of groove 20 and parallel with the face of the fire-box section. At the opposite or outside edge of groove 20, socket-enlargement 19 takes the form of a flange 22 which projects substantially at right angles to the face of the fire-box section. Bead 18 of one fire-box section having been located within groove 20 of the adjoining section, lip 21 serving as a guide and retainer for this purpose, the two sections are permanently connected to form a gas and dust-proof joint by means of a metal strip 23 having one side of its inner edge transversely curved at 24 to conform to the curvature of bead 18. Thus, it will be seen that, when strip 23 is secured in place on the outer face of flange 22 by means of bolts 25 located in corresponding open-

ings in the parts, the adjoining fire-box sections will be securely connected along their abutting edges, the curved edge 24 of strip 23 serving not only to prevent the removal of bead 18 from groove 20 but also to firmly bind or clamp the bead in the groove. Flanges 22 on the fire-box sections 13 do not extend to the lower edges of the sections but, together with strips 23, are cut off obliquely at 26 so as to preclude any possibility of interference therewith of flange 9 on ash-pit 5, which might prevent freedom of movement of the parts when the fire-box expands under heat.

The rear wall of the fire-box 12 is formed by plates or sections 27 bolted together at 28 through suitable flanges provided thereon, while at their outer edges sections 27 are suitably connected to the adjoining edges of the rearmost fire-box sections 13. Sections 27 rest, as do sections 13, in the groove 8 provided on ash-pit 5. The top edges of rearmost sections 13, the rear edge of rearmost top section 14 and the upper edges of rear sections 27 are also flanged to provide for bolting thereto member 29 which is correspondingly flanged on its adjoining edges for this purpose. Member 29 has two openings 30, 31 in its upper wall which lead respectively into the lower open ends of rear breechings 32, 33 attached to the upper surface of member 29 over these openings. Breechings 32, 33 present prime radiating surface to the fire at all times and, as they open directly into the rear end or extension of fire-box 12, they are self-cleaning, the soot falling down into and being consumed in the fire-box 12.

The front end of fire-box 12 is formed by a member 34 flanged on its rear edge for bolting to the front edges of the foremost fire-box sections 13 and 14 which are also flanged for this purpose. Extending forwardly from the outer face of member 34 and secured thereto about the fuel-opening 35 is an extension or flange 36 which projects freely through the corresponding fuel door opening 37 in the ornamental front 1.

Above front fire-box member 34 and the foremost fire-box sections 13 and 14, is located the front breeching 38 which is curved transversely to conform to and rest on the top of the fire-box 12. The front wall of breeching 38 has an opening 39 therein which is surrounded by an outstanding flange or extension 40, similar to extension 37 on member 34, which projects freely through an opening 41 provided therefor in the upper part of ornamental front 1, there also being provided a door 42 on ornamental front 1 which normally closes this opening.

With the improved front construction just described, it will be seen that the expansion of the furnace may take place without in

any wise disturbing ornamental front 1 which, as stated, is set up in masonry. Door 42 also provides for ready access to the breeching 38 and its connected parts for
5 cleaning purposes.

Each of rear breeching 32 and 33 and the corresponding side of front breeching 38 is connected together by a group of specially designed horizontal radiator tubes or flues
10 43. Tubes 43 have suitably attached thereto or formed thereon longitudinally-spaced, upstanding casings 44 which are imperforate except for their lower open ends which register with corresponding openings 45 provided
15 in the upper portions of tubes 43. The upper edges of casings 44 are rounded to avoid any angles within the members in which soot might accumulate, thereby rendering them self-cleaning. Members 44
20 form pockets or recesses in flues or tubes 43 which not only increase the heat-radiating surface of the latter, but also tend to retard the flow of the products of combustion through the flues and thereby utilize more
25 efficiently the heat present therein.

A horizontal smoke pipe 46 leads centrally from the front breeching or smoke box 38 between the two groups of radiator flues 43 to the uptake 47 at the rear of the furnace,
30 the rear end of the smoke pipe 46 being closed by a plate 48 secured therein. A suitable bracket 50 located on top of member 29 receives and supports the rear end of smoke-pipe 46 in proper position.

The course of the products of combustion during the operation of the furnace is clearly indicated by the arrows in the several figures of the drawings. The products pass from the fire on grate 11 rearwardly into the rear
40 extension of the fire-box 12 and then upwardly through openings 30 and 31 in member 29 into rear-breechings 32, 33. Thence they move to the front breeching or smoke-box 38 through the two groups of horizontal radiator tubes or flues 43 in which latter, as
45 stated before, their flow is retarded somewhat due to the presence of the upstanding pockets or recesses formed by casings 44 into and out of which more or less of the products flow during their forward course to
50 front breeching 38 thereby increasing the heat radiation of the furnace. As the only opening in front breeching 38 is that into smoke-pipe 46, and as the latter at its rear end leads to the uptake 47, the products of
55 combustion and gases will pass rapidly out of breeching 38 and through smoke-pipe 46 to up-take 47.

In the construction described, efficient gas and dust-proof joints are provided at vital
60 points in the structure, the arrangement of the various parts is simplified and ample provision made for replacement of parts. Expansion and contraction of the fire-box
65 and connected parts are provided for and

the maximum heat-radiating capacity of a furnace of this type fully and completely utilized.

What is claimed is:

1. In a furnace of the character described, 70 the combination of a fire-box; a front breeching located above the fire-box; a rear breeching located above and communicating with the rear of the fire-box; heat-radiating flues connecting said front and rear breechings, 75 said flues being provided with outwardly projecting pockets opening into the flues for retarding the flow of products of combustion therethrough and increasing the heat-radiation thereof; a smoke-pipe extending rear- 80 wardly of the furnace from said front breeching; and an up-take for said smoke-pipe.

2. In a furnace, the combination of a fire- 85 box having a pair of openings in the rear portion of its upper wall; a pair of rear breechings mounted on the rear end of the fire-box and having their lower open ends in registry with said pair of openings in the fire-box to provide unobstructed upright 90 passageways between the rear breechings and the fire-box; a front breeching located above the fire-box; a pair of groups of heat-radiating tubes connecting the rear breechings with the corresponding sides of the front 95 breeching; a smoke-pipe extending rearwardly of the furnace from said front breeching and between the pair of groups of heat-radiating tubes; and an up-take extending from the smoke-pipe between said 100 pair of rear breechings.

3. In a furnace, the combination of a fire- 105 box formed of sections, said sections being provided on their abutting edges with continuous integral beads, circular in cross-section, and continuous, integral sockets to receive said beads; strips coextensive with said beads for clamping the beads in their corresponding sockets; means for detachably securing said strips in place; a pair of rear 110 breechings located above the fire-box, said breechings being open at their lower ends and communicating with the rear of the fire-box through corresponding openings provided in the upper wall thereof; a front 115 breeching located above the fire-box; a pair of groups of heat-radiating flues connecting said pair of breechings with the corresponding sides of the front breeching, said flues being provided with outwardly projecting pockets opening therein for retard- 120 ing the flow of the products of combustion through the flues to increase the heat-radiation thereof; a smoke-pipe extending rearwardly of the furnace from the front 125 breeching; and an up-take connected to the smoke-pipe between the pair of rear breechings.

4. In a furnace, the combination of a fur- 130 nace front having upper and lower openings

therein; a fire-box having a fuel opening in its front wall; a tubular extension on the fire-box about said fuel opening and projecting freely through said lower opening in the furnace front; a rear breeching open at its lower end and registering with a corresponding opening in the top of the rear of the fire-box so as to provide an unobstructed upright passageway; a front breeching having an opening in its front wall; a tubular extension on the front breeching about said opening and projecting freely through said upper opening in the furnace front; heat-radiating flues connecting said front and rear breechings, said flues being provided with outwardly projecting pockets opening into the flues for retarding the flow of products of combustion therethrough; a smoke-pipe extending rearwardly of the furnace from the front breeching; and an up-take for said smoke-pipe.

5. In a furnace, the combination of a fire box open at the upper portion of its rear end; a rear breeching mounted on the rear end of the fire box and having its lower open end in registry with the open end of the fire box to provide an unobstructed upright passage way between the rear breeching and the rear end of the fire box; a front breeching; a pair of groups of heat radiating tubes connecting the rear breeching with the front breeching; a smoke pipe extending rearwardly of the furnace from said front

breeching, between the pair of groups of heat radiating tubes, and supported at its rear end by the top of the fire box; and an uptake extending from the rear end of the furnace pipe.

6. In a furnace, the combination of a one-piece, metallic front having upper and lower openings therein; a closure for said upper opening; a closure for said lower opening; an ash pit structure connected to said front; a fire box supported by said ash pit structure and adapted for relative movement therewith to permit expansion and contraction of the parts, said fire box having a fuel opening in its front wall; a tubular extension on the fire box about said fuel opening, said extension projecting freely through the lower opening in the front; a rear breeching supported by said fire box; a front breeching having an opening in the front wall thereof; a tubular extension on the front breeching about said opening, said extension projecting freely through the upper opening in the front; heat radiating flues connecting said front and rear breeching; a smoke pipe extending rearwardly of the furnace from the front breeching; and an uptake connected to the rear end of the smoke pipe.

PATRICK H. MA GIRL, DECEASED,
By JAMES D. MA GIRL,
IDA E. DALTON,
GERTRUDE A. JOHNSTON,
Executors.