

(No Model.)

4 Sheets—Sheet 1.

W. M. DUNAWAY.

COMBINATION COUPON TICKET STAMP AND PUNCH.

No. 401,420.

Patented Apr. 16, 1889.

Fig. 1.

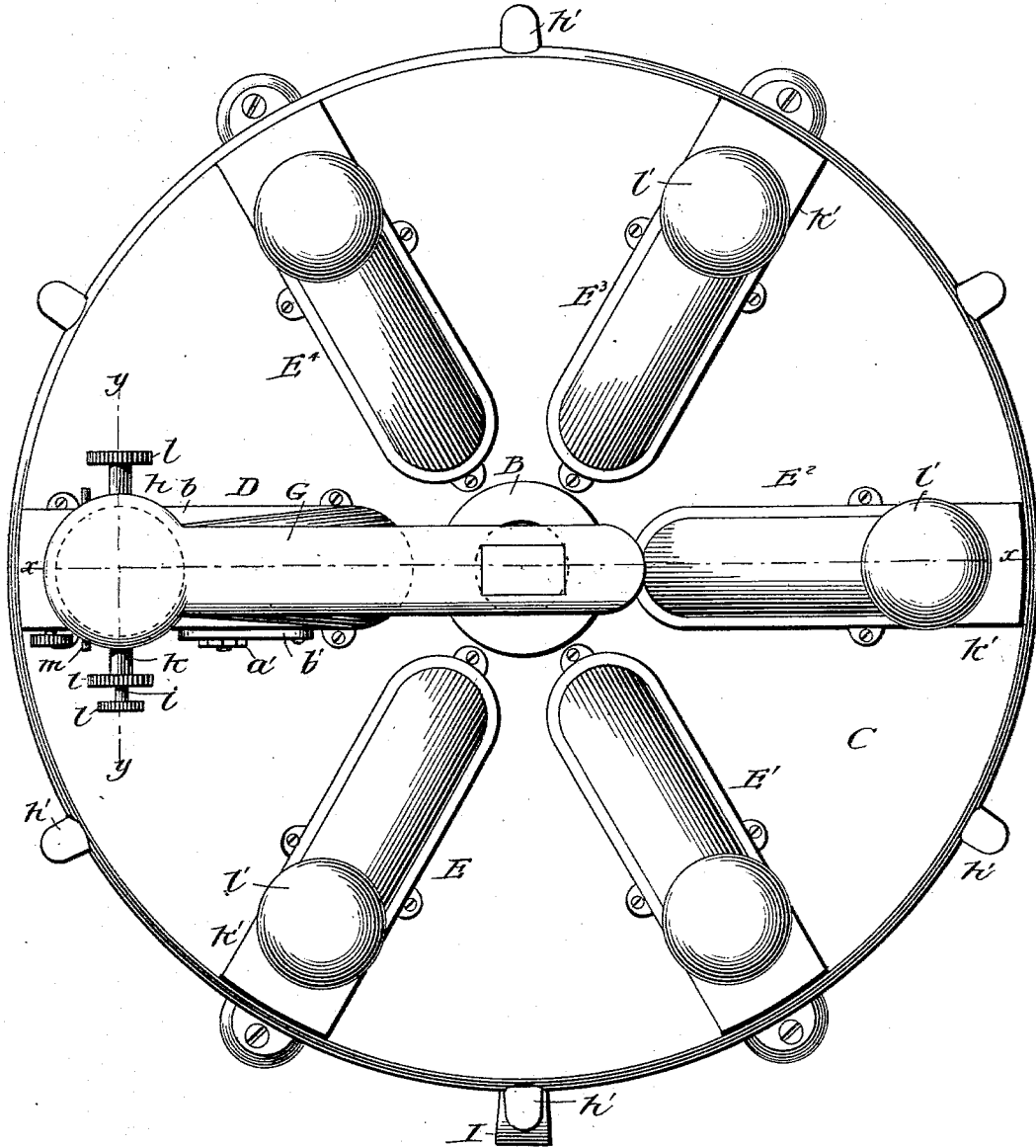

WITNESSES:

J. Clark
W. Sedgwick

INVENTOR.

W. M. Dunaway

BY

Munn & Co

ATTORNEYS.

(No Model.)

4 Sheets—Sheet 2.

W. M. DUNAWAY.

COMBINATION COUPON TICKET STAMP AND PUNCH.

No. 401,420.

Patented Apr. 16, 1889.

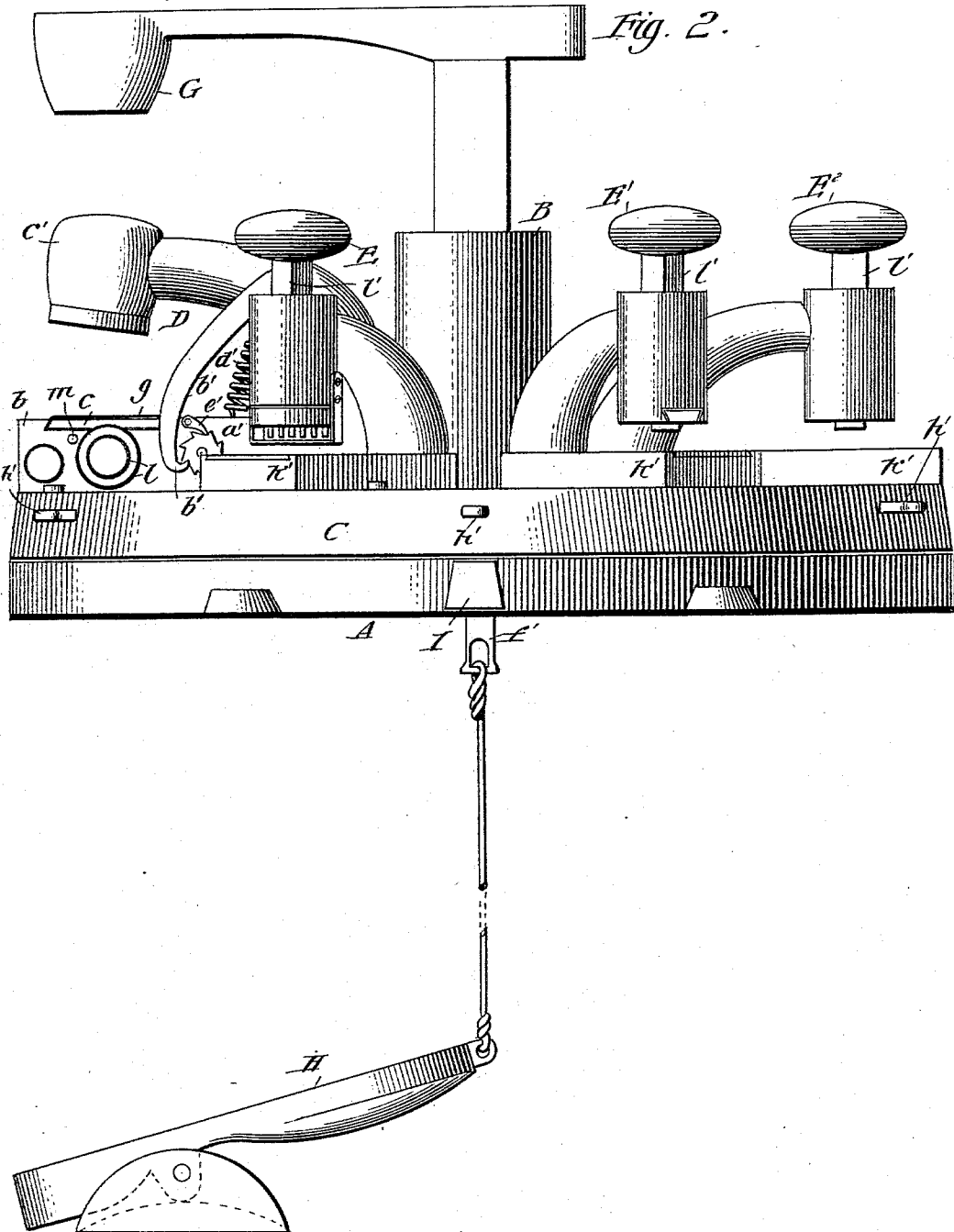

WITNESSES:

J. Clark
W. Bedgwick

INVENTOR.

W. M. Dunaway

BY

Munn & Co

ATTORNEYS.

(No Model.)

4 Sheets—Sheet 3.

W. M. DUNAWAY.

COMBINATION COUPON TICKET STAMP AND PUNCH.

No. 401,420.

Patented Apr. 16, 1889.

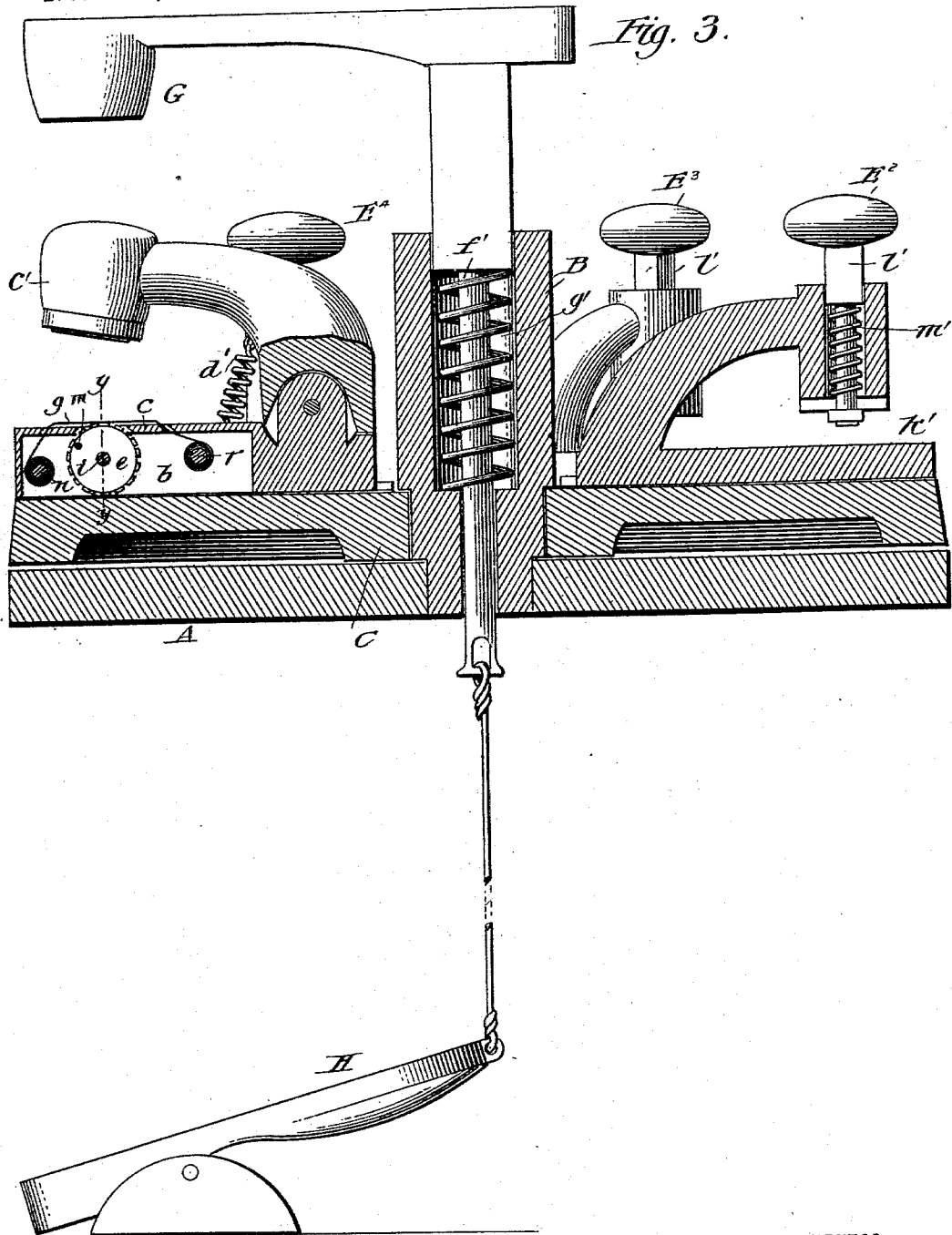

WITNESSES:

J. Clark
G. Betzwick

INVENTOR.

W. M. Dunaway
 BY *Munn & Co*
 ATTORNEYS.

(No Model.)

4 Sheets—Sheet 4.

W. M. DUNAWAY.

COMBINATION COUPON TICKET STAMP AND PUNCH.

No. 401,420.

Patented Apr. 16, 1889.

Fig. 4.

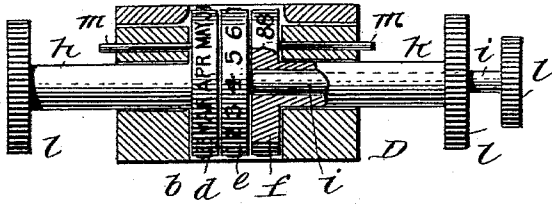

Fig. 5.

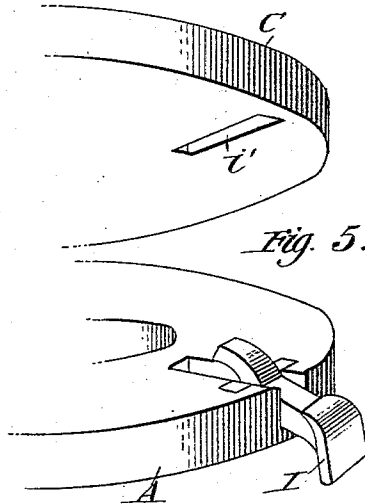
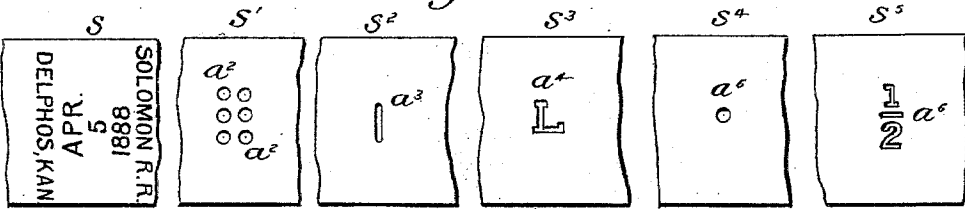

Fig. 6.



WITNESSES:

J. Clark
L. Sedgwick

INVENTOR.

W. M. Dunaway
 BY *Munn & Co.*

ATTORNEYS.

UNITED STATES PATENT OFFICE.

WILSON M. DUNAWAY, OF DELPHOS, KANSAS.

COMBINATION COUPON-TICKET STAMP AND PUNCH.

SPECIFICATION forming part of Letters Patent No. 401,420, dated April 16, 1889.

Application filed May 22, 1888. Serial No. 274,732. (No model.)

To all whom it may concern:

Be it known that I, WILSON M. DUNAWAY, of Delphos, in the county of Ottawa and State of Kansas, have invented a new and improved Combination Coupon-Ticket Stamp and Punches, of which the following is a full, clear, and exact description.

This invention consists in an apparatus of novel construction mainly for the use of railroad-ticket agents, in which a coupon-ticket stamp and punches are combined for indicating on or in the ticket the date of the ticket, the destination for which the ticket is issued, and other particulars, restrictions, or limitations, the whole devices for these different purposes being mounted upon an adjustable revolving table controlled by a suitable catch for bringing the stamp and punches respectively and successively under a hammer or striker common to them all and operated by a foot-treadle, which leaves the hands of the operator at liberty to turn or adjust the revolving table as required, and to manipulate the ticket as needed, substantially as hereinafter described, and pointed out in the claims.

Reference is to be had to the accompanying drawings, forming a part of this specification, in which similar letters of reference indicate corresponding parts in all the figures.

Figure 1 represents a plan view of a combined coupon-ticket stamp and punch embodying my invention. Fig. 2 is a side elevation of the same; Fig. 3, a vertical section thereof, mainly upon the line *x x* in Fig. 1; Fig. 4, a transverse vertical section through the ticket-stamp, mainly upon the lines *y y* in Figs. 1 and 3. Fig. 5 is a view in perspective of the under side of the revolving table in part and of the stand or base in part, upon or over which said table revolves, together with an attached catch that engages with the table. Fig. 6 is a face view of the tickets in part, in illustration of the work done by the apparatus.

A indicates the base or stand, having a hollow central upright, B, upon or around the lower portion of which the table C is fitted to revolve immediately above the base A. Upon and around this table C are arranged at equal distances apart a stamping device,

D, and a series of punching devices, E, E', E², E³, and E⁴.

The stamping device D is what I term the "ticket-stamp," which resembles somewhat other dating devices by printing through a ribbon on the ticket, but which combines with it certain details having a special operation. Thus *b* is the hollow base-piece of the ticket-stamp, having an opening in its top, which is closed by an apertured slide-plate, *c*, secured by set-screws, and that has upon its upper surface the name of the particular railroad and of the town and State in which the ticket is issued. Arranged within the hollow base-piece *b* are three type-wheels, *d e f*, placed side by side and projecting up within the aperture of the plate *c*, over which the marking or printing ribbon *g* works. These wheels are capable of independent adjustment by means of separate spindles *h i k*, having separate operating thumb disks or heads *l*. The one outer one, *d*, of these wheels has on it the months of the year, the other outer one, *f*, has on it a series of years beginning with the current one, and the middle wheel, *e*, numbers indicating days of the month from 1 to 31. These several wheels after being adjusted or set for a particular date—that is, month, day of the month, and year, as exposed through the aperture in the plate *c*—are held to their position by spring or other locking-pins *m m*, arranged to bear against the two outside wheels, *d f*; but upon drawing outward on these pins the several wheels *d e f* may be independently turned whenever a change of dates or periods is required.

The ribbon *g* is automatic in its action, the same being attached at its one end to a delivery-roller, *n*, which may be turned, when required, by an exterior thumb-wheel when necessary to return the ribbon after it has run its full length, and its other end being attached to a take-up roller, *r*, upon the spindle of which is a ratchet, *a'*, with which a pawl, *b'*, engages and operates every time the lever stamping arm or head *c'* rises after the required impression has been made upon the ticket by the descent or blow of the stamping-arm upon the ticket as the latter is placed on the ribbon *g* and over the plate *c* and wheels

d e f. A spring, d' , serves to throw up the stamping-arm after the impression has been made and to supply fresh ribbon surface for a succeeding impression, a pawl, e' , holding the take-up roller r against back action. The whole ticket-stamp D may either be permanently or removably secured upon the rotating table C, and the stamping-arm c' is brought down when required to make an impression by causing a hammer or striker, G, to bear rapidly or forcedly down upon the head of the stamping-arm c' through the instrumentality of a treadle, H, to which the operator's foot is applied, and which is connected to a vertically-sliding rod, f' , carrying the striker G and fitted to work up through the hollow central upright, B, within which is a spring, g' , that lifts said rod and treadle after they have been depressed and gives a lively action to the treadle motion.

The table C, it should be remembered, is a rotatable one, and may be turned as required—as, for instance, by means of finger-pieces h' on its periphery—to bring either the ticket-stamp D or any one of the punching devices E, E' , E^2 , E^3 , and E^4 directly under the hammer or striker G. To stop the table automatically at its proper point for the hammer or striker G to act upon either the ticket-stamp or any one of the punching devices and to hold the table when so adjusted, the base A is fitted with a weighted pivoted catch, I, made to engage automatically with any one of a series of suitably-arranged notches in the under side of the rotating table, said notches corresponding to the distances apart of the ticket-stamp and punching devices. The drawing Fig. 5 only shows one of these notches i' ; but it will be understood that there are the same number of notches as there are devices to be operated by the hammer or striker G. To disconnect the table C from its lock with the base A when it is required to turn or adjust the table, the catch I is raised by applying the finger to its outer end.

The several punches E, E' , E^2 , E^3 , and E^4 are mainly each composed of a bed-piece, k' , and vertically-sliding punch-stocks l' , held or forced upward by a spring, m' , and having a head on their upper ends, upon which the hammer or striker G comes down to produce the required impressions or perforations by forcing downward the punch-stock l' . Like punches making different marks are in ordinary but separate use for similar purposes. The same, however, have not heretofore been combined upon a rotating table.

The bed-piece b of the ticket-stamp and the bed-pieces k' of the several punches are separate and independent from each other, and are detachably secured to the revoluble table by means of screws passed through laterally-projecting lugs or ears, as best shown in Fig. 1.

Fig. 6 of the drawings shows the work that may be done upon the ticket when placed upon the bed parts of the ticket stamp or

punches, and bringing the hammer or striker G down upon the ticket-stamp or either of the punches when adjusted into position for the purpose by rotating the table C. Thus the portion of the ticket indicated at s represents the work done by the ticket-stamp D. The punch E is what is called a "destination-punch," and is constructed to make rows of perforations a^2 , as shown, for the portion of ticket s' , the station appearing between said rows of perforations indicating the destination of the ticket. The punch E' is constructed to make any special-shaped aperture—as shown, for instance, at a^3 in the portion of ticket marked S^2 —to indicate the class of conveyance to which the ticket applies—such as first, second, or third class. The punch E^2 is what is termed the "limit-punch," and is constructed to make an L-shaped perforation in the ticket, as shown at a^4 , in the portion of ticket marked s^3 , to indicate that the ticket is a limited one. The punch E^3 is a "canceling" one or "dating" one, as it may be termed, and is constructed to make a hole, a^5 , as shown, in the portion of ticket marked s^4 , through a date or dates on the ticket, to indicate how many days the ticket is limited for. The punch E^4 is constructed to mark or punch out of the ticket the denominational symbol $\frac{1}{2}$, as shown at a^6 , in the portion of ticket marked s^5 , to indicate that the ticket is a half-fare one.

Of course only such of the punches may be used as occasion requires by suitably turning the table C to bring a particular punch under the hammer or striker.

The invention, although here only described in such connection, is not restricted to railroad ticket stamps and punches; but any other stamps, daters, and punches, with their pertaining devices, may be used upon the revolving table—as, for instance, such stamps and daters or punches as will be suitable for banking-houses, counting-houses, and other offices or places.

Having thus described my invention, what I claim as new, and desire to secure by Letters Patent, is—

1. A combined ticket stamp and punch consisting, essentially, in the stationary base A, revoluble table mounted thereon, a vertically-reciprocating hammer or striker above said table, a ticket-stamp, and a series of punches, each having a separate and independent bed-piece detachably secured to the upper side of the revoluble table, said punches and stamp being arranged to allow of their being brought under the hammer or striker, substantially as set forth.

2. The combination, with the stationary base having a tubular bearing, a circular revoluble base on said bearing, the vertically-reciprocating hammer having an operating-rod extending down through the tubular bearing, a spring throwing said rod upward, and a treadle connected with the lower end of the

rod, of the stamping device and punches on top of the table concentrically arranged with its axis, substantially as set forth.

5 3. The combination, with the stationary base having a catch, I, projecting at its inner end above the face thereof, and the vertically-reciprocating hammer, of the circular revoluble table having a stamping device and radial

punches concentrically arranged with its axis, and provided with a series of concentric notches, *i*, substantially as set forth.

WILSON M. DUNAWAY.

Witnesses:

PATRICK BRADY,
THOS. BROWN.