

B. E. ELDRED.
LIMEKILN.

APPLICATION FILED FEB. 18, 1901. RENEWED JUNE 28, 1905.

Fig. 2.

Fig. 1.

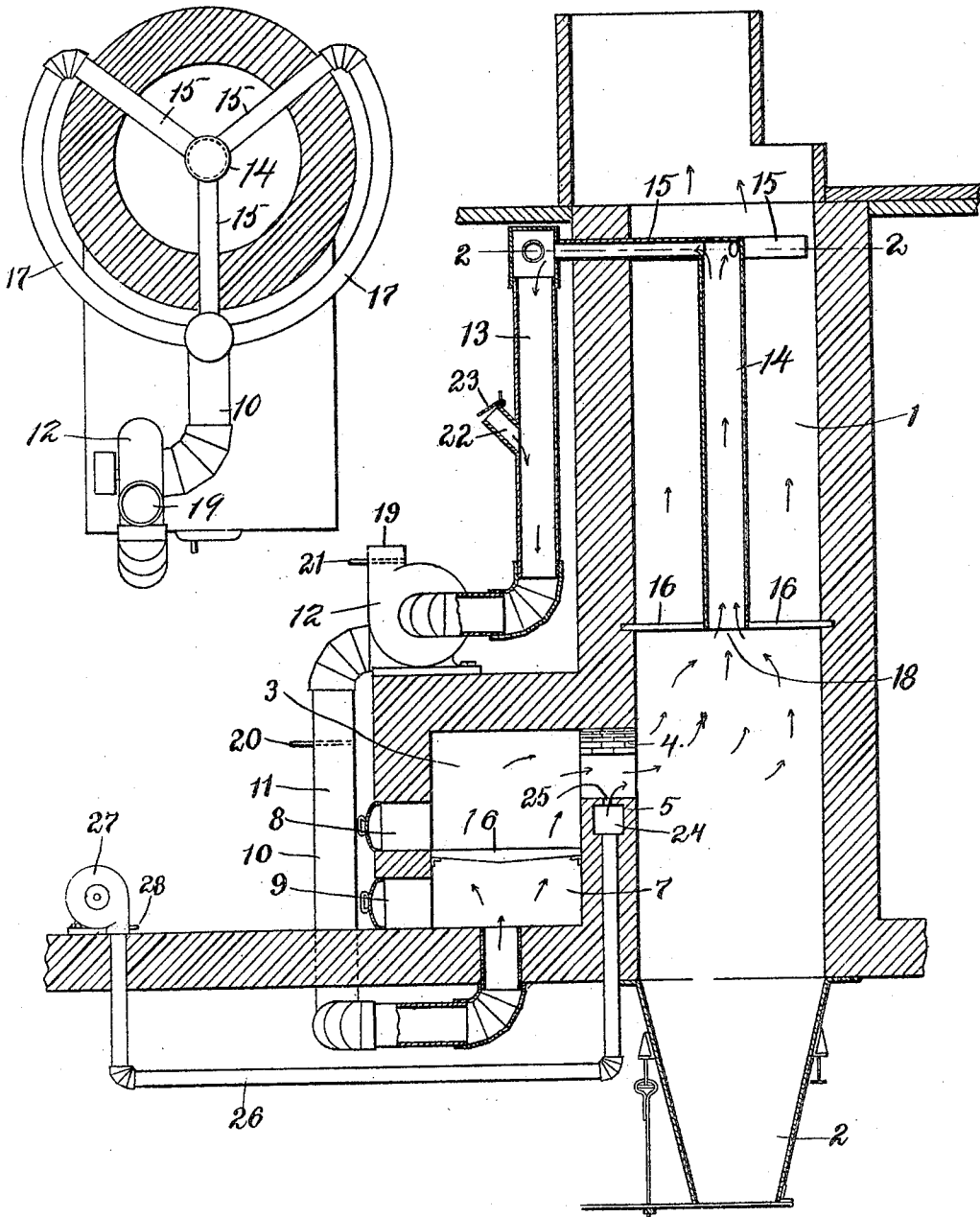

WITNESSES.

A. W. Pezzetti
E. B. Scheller

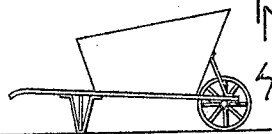

INVENTOR
B. E. Eldred
by *Wm. B. Brown*
attor

UNITED STATES PATENT OFFICE.

BYRON E. ELDRED, OF BROOKLINE, MASSACHUSETTS, ASSIGNOR TO
ELDRED PROCESS COMPANY, OF NEW YORK, N. Y., A CORPORA-
TION OF NEW YORK.

LIMEKILN.

No. 798,023.

Specification of Letters Patent.

Patented Aug. 22, 1905.

Application filed February 18, 1901. Renewed June 28, 1905. Serial No. 267,448.

To all whom it may concern:

Be it known that I, BYRON E. ELDRED, of Brookline, in the county of Norfolk and State of Massachusetts, have invented certain new and useful Improvements in Limekilns, of which the following is a specification.

The object of this invention is to control the temperature, volume, and duration of flame or combustion.

It consists in a means or apparatus whereby in place of the ordinary pure-air draft which it is customary to supply to a fire the combustion of the fuel is conducted by means of an artificially-accelerated draft composed of air and a neutral gaseous diluent. I am thereby enabled to greatly retard the liberation of the heat units of the fuel and to produce a long flame of large volume.

An important application of my invention is in the burning or calcining of lime, in which art or industry it effects great economies in the cost of the process and improvement in the quality of the product, and I have herein-after described my invention in connection with lime-burning, although I do not consider it as limited to this art.

The usual method of burning lime under the continuous process with external fires is by the use of wood as fuel. Wood has a comparatively low calorific power, yielding sufficient heat to effect the calcination of the lime-rock without overburning the lime; but its cost as a fuel is high in most localities as compared with that of coal, and the available supply is constantly diminishing. The employment of coal in place of wood as fuel with ordinary methods of conducting combustion results in overburning of the lime. The calorific power of coal being much higher than that of wood, the intense heat developed by its combustion results in the formation of a slag by the melting of fusible impurities in the lime-rock, and there is obtained a product which will not slake thoroughly or only after a long period, often slaking to some extent after it has been made up into plaster or mortar and applied to buildings or elsewhere, producing the very undesirable effect known as "pitting." The combustion of an ordinary coal fire in a kiln takes place mainly within the fire-box and is expended upon the fire-box walls rather than upon the lime-rock, causing rapid deterioration of linings and producing a short flame

of small volume, which is incapable of properly filling the cross-section of the kiln-body and burning the mass of rock uniformly throughout, but instead climbs the walls of the kiln, where the draft is strongest, and burns the lime at the sides more rapidly than at the center. Any artificial acceleration of a pure-air draft through a coal fire merely tends to intensify the combustion and increase the rapidity with which the heat units are evolved, and such an expedient has never, so far as I am aware, been resorted to in a limekiln without increasing the evils which arise from an already too intense supply of heat. My invention enables me to use coal without overburning the lime and to obtain practically perfect combustion from very inferior grades of coal.

In applying my invention to the burning of lime with external coal-fires I pass through the fire as a draft-current or draft under artificial acceleration furnished by any suitable means, such as a fan-blower, a mixture of air and a neutral gaseous diluent. The latter may conveniently be derived from the kiln itself in the form of the gaseous products of the calcination of the lime and the combustion of the fuel. The gas driven off by heating the limestone is carbon dioxide or carbonic acid, (CO₂), and the products of combustion are mainly free nitrogen and carbon dioxide, both of which are neutral as respects combustion—that is to say, they are non-combustible in oxygen and are non-supporters of combustion. They act as a diluent and carrier for the air. This artificially-accelerated draft when passed through the coal-bed on the grate maintains the combustion of the coal sufficiently to produce a rapid and abundant evolution of combustible gases; but on account of the dilution of the air in the draft by the kiln-gases, the expansion which it undergoes by being heated by these gases, and the speed of the draft combustion is incomplete within the fire-box and a considerable quantity of fuel-gases escapes into the body of the kiln. Here the heating agent—namely, the flaming draft or current which passes off from the fuel-bed—may be supplied with additional air to complete the combustion of the fuel-gases and obtain the maximum evolution of heat which they are capable of affording. The final evolution of heat from the fuel takes place within the body of lime-rock to a

far greater extent than when the fires are supplied with a pure-air draft. In other words, the heat of the fuel is evolved at the point where it is needed and where it can do direct work in calcining the lime and is not uselessly expended in overheating the fire-box walls and overburning the lime at the mouth of the fire-box. It naturally follows that this apparatus effects great economy in fuel.

Of the accompanying drawings, Figure 1 represents a vertical section of a kiln equipped with my improvement. Fig. 2 represents a horizontal section on the line 2-2 of Fig. 1.

The same reference characters indicate the same parts in both figures.

Referring to the drawings, 1 represents the cupola or calcining-chamber of the kiln, in which the material to be calcined is placed, the said cupola having an upper outlet to the atmosphere, and 2 represents a cooler at the lower end of the calcining-chamber. The broken stone or other fragmental material to be calcined is fed into the top of the cupola 1, and the burned lime is from time to time withdrawn from the cooler 2.

3 is a fire-box or burner, of which there may be more than one, communicating with the cupola 1 through an opening or arch 4 and having a bridge-wall 5, grate 6, and ash-pit 7 below the grate.

8 and 9 are the fire and ash-pit openings, provided with suitable doors.

10 is a draft pipe or conduit connecting at its upper end with a flue 14 in the cupola and at its lower end with the ash-pit 7 and having interposed in it a fan-blower 12. The part 13 of the conduit 10 above the fan 12 constitutes the suction-pipe of said fan, and the part 11 below the fan constitutes a delivery-pipe therefor. A gate or valve 20 controls this delivery-pipe. The fan has also an auxiliary outlet or delivery-pipe 19, controlled by a gate or valve 21, through which a portion of the kiln-gases may be disposed of without causing them to pass through the fire. At 22 the suction-pipe 13 is provided with an air-inlet controlled by a valve 23. By adjusting this valve the relative proportion of air and kiln-gases in the draft may be exactly controlled.

The flue 14 is placed vertically and centrally in the cupola, with an inlet-orifice 18 at its lower end, and is supported from the walls of the kiln by radial upper and lower arms 15 16. The upper arms 15 are hollow and in connection with outside pipes 17 17 form passages connecting the flue 14 with the upper end of draft-pipe 10. To prevent the flue from burning out, it may be constructed of refractory material or protected in any suitable manner. While the flue has a beneficial effect in drawing the flame into the center of the lime-rock, yet it is in no wise essential to the proper carrying out of my invention and

may be omitted and the kiln-gases drawn from any convenient point in the cupola.

The bridge-wall 5 is provided with a conduit 24, having outlets 25 along the crest of the wall and connected by a conduit 26 with an auxiliary fan-blower 27, the blast from which is regulated by means of a gate or valve 28 in the conduit. A supply of air capable of being accurately regulated is thereby added to the heating agent or outdraft from the burner 3 as this outdraft passes into the body of lime-rock in order to complete the combustion of the fuel-gases within said body of rock. The final air-supply may be added in any other suitable manner and at a different point or points, if desired, and furthermore I do not limit myself to supplying pure air or any additional air to effect final combustion. The whole amount of air necessary to support combustion may, if desired, be supplied in the main draft. These and other details I consider may be varied without departing from my invention, which I believe to be the first apparatus aiming to retard combustion by the use of waste stack-gases or similar diluent in the draft-current. Prior efforts at using stack-gases have uniformly been directed toward a large saving of waste heat units and at an increased intensity of combustion, whereas I succeed in substantially retarding the combustion and supply the stack-gases in such a condition as to effect a cooling or limiting of temperatures which would otherwise be much higher. These gases are somewhat cooled by the outside flue and by the lime-rock and are furthermore very rich in CO₂, which may have a substantial cooling effect on the fuel-bed under certain conditions. One of the results which I regard as important is that the fire-box or burner is kept relatively cool by the operation of this apparatus.

During the operation of the kiln the door covering the ash-pit opening 9 is kept closed, so that a forced draft may be obtained through the body of fuel on the grate, and the whole of the draft for the fire is supplied through the pipe 10. The fan 12 is run at such speed as to accelerate this draft to a considerable extent above the speed of the natural draft of the fire, and thereby to secure a vigorous expulsion of the flame and gases proceeding from the fuel-bed from the burner into the cupola. I thereby insure a direct penetration of the heating agent to the central portions of the lime-rock in the kiln which is unobtainable under a natural draft. Combustion itself takes place to a greatly-increased extent within the body of lime-rock, and the furnace is cooler than with a pure-air draft. One effect of the diluent kiln-gases is to attenuate the oxygen and the combustible gases evolved from the fuel-bed, so as to render it more difficult for each to find the other and combine. Combination eventually takes place and combustion is

very complete before the top of the cupola is reached; but having been retarded until the heating agent reaches the cupola it is effective to an increased degree. The visible effect of the diluted air-draft is a great increase in the volume of flame. Within the mass of lime-rock the body of diluent gases acts as an absorber and carrier of the heat of combustion, which distributes this heat uniformly throughout the mass and lowers the temperature of combustion.

In a limekiln the body of rock within the zone of calcination is raised to a state of incandescence and acquires a temperature amply sufficient and in excess of the temperature which is required to ignite a mixture of air and fuel gases. In other words, the body of lime-rock acts as a heat accumulator or storer. It will readily be seen that this is a condition conducive to perfect combustion and favorable to the existence of flame or combustion at a long distance from the seat of initial combustion or the source of the heating agent. The presence of a heat-retainer or other means to maintain ignition is a condition which should also be supplied in order to obtain the best results in applying my invention to other arts or processes.

In carrying out my invention I employ a draft mixture of air and neutral gaseous diluent in the proportion of about three or four volumes of air to one volume of the gases; but this proportion may be varied without departing from the invention, depending upon the conditions under which the process is carried out.

The herein-described method or process is separately claimed in my patent for method of calcining lime, &c., No. 692,257, dated February 4, 1902.

I claim—

1. In a kiln apparatus, the combination of a calcining-chamber provided with a burner for lateral firing, a conduit structure having connections for deriving a supply of air and a neutral diluent mixed therewith, entering the burner at a point anterior to the point of fuel support or supply, whereby combustion is retarded, means for impelling the mixture under artificial acceleration through the conduit structure and through the burning fuel, and means for varying the proportion of ingredients in the mixture.

2. In a kiln apparatus, the combination of a calcining-chamber having a burner, conduit structure having a connection with said chamber for deriving a neutral gas therefrom to cool the burner together with means for supplying air to said structure, said structure entering the burner at a point anterior to the point of fuel support or supply, means for artificially accelerating the gaseous mixture through said conduit structure and through the burning fuel, and means for varying the proportion of the ingredients in said mixture.

3. The combination of a kiln, a burner appurtenant thereto and having a seat of combustion and a draft-chamber antecedent to said seat and arranged for the maintenance of an artificially-accelerated draft, a draft-conduit connecting the interior of said kiln with said draft-chamber, draft-accelerating means in said conduit, and an air-inlet to said conduit on the suction side of said means, the arrangement being such as to promote cool combustion.

4. In a kiln apparatus, the combination of a calcining-chamber provided with a burner for lateral firing, a conduit structure having connections for deriving a supply of air and a neutral diluent, entering the burner at a point anterior to the point of fuel support or supply, means for impelling the mixed draft under artificial acceleration through the conduit structure and through the burning fuel, all so arranged as to substantially cool the burner, and means for supplying additional air to the outdraft from the burner at a point posterior to said point of fuel support or supply.

5. In combination, a furnace having its flame-passage of a refractory character and adapted for treatment of materials of a heat-retentive character whereby ignition of the flame in said furnace may be prolonged, a fuel-burner arranged to operate under forced draft, means to supply a forced-draft current to said burner, and means whereby a portion of the waste gases from said furnace is returned to the draft-supply passage of the burner in condition to retard the combustion of the burner fuel.

6. In combination, a fuel-burner adapted for the combustion of a bed of solid fuel, a source of diluent fixed gas, an air-inlet, and means whereby a draft-current composed of the air and the diluent gas is supplied in such condition as to substantially retard combustion and passed into the fuel-bed in said burner, the arrangement being such as to artificially accelerate the draft-current in the fuel-bed.

7. In combination, a limekiln furnishing carbon dioxide from the lime material, a burner adapted for the combustion of a bed of solid fuel, means to furnish a draft-current containing oxygen and kiln-gases to pass through the fuel-body, and means whereby said draft-current is passed into the fuel-body under forced draft.

8. In combination an upright-shaft limekiln, an external coal-burner for heating the same, means for supplying diluent fixed gas and air in predetermined proportions to the ash-pit of said burner, and means for maintaining a pressure above atmosphere in said ash-pit.

9. In combination, a limekiln, a burner for heating the same having means for supporting a bed of fuel, means for supplying beneath the fuel-bed air and a small portion of the waste

kiln-gases, and means for providing and maintaining a pressure above atmosphere beneath the fuel-bed.

10. The combination of an upright cupola-furnace adapted to contain and pass a body of the material to be treated, an external fuel-burner, means for supplying air and products of combustion to the burner to retard combustion, and means to artificially assist the passage of the draft-current through the fuel-bed.

11. The combination of an upright shaft or cupola-furnace having means for introducing the material at the upper end and withdrawing it at the lower end, a fire-box appurtenant thereto and adapted for burning coal, means for supplying air and a small portion of the waste furnace-gases to the fuel-bed, and means whereby the combustion is conducted under forced draft.

12. In combination, a furnace for supplying waste gases to be employed as a diluent, a fuel-burner having provision for conducting combustion under forced draft, and means for supplying and passing through the seat of combustion of said burner an accelerated air and waste-gas draft-current of a temperature and composition suited to substantially retard the said combustion.

13. In combination, a limekiln having a main outlet for the kiln-gases, an external fuel-burner to heat said kiln, a return-conduit branching from the kiln-chamber and leading to the draft-supply chamber of the burner, a fan-exhauster in said conduit, an air-inlet to the conduit on the suction side of the fan, whereby air and a small portion of waste kiln-gases in a desired ratio may be returned to the burner and passed through the fuel, and an adjustable valve in said conduit

on the discharge side of the fan for controlling the amount of draft-current admitted to the draft-chamber of the burner.

14. In combination, a limekiln, a coal-burner for heating the same having a closed ash-pit, a return-conduit for waste kiln-gases connecting with the ash-pit, a fan-exhauster in said conduit, an air-inlet to said conduit on the suction side of the fan, and means for effecting a predetermined adjustment of the ratios of air and waste gases admitted to the fan.

15. In combination, a coal-burner, a furnace-chamber connecting with said burner and having means for the introduction and removal of the materials under treatment, means for supplying to said burner for passage through the coal-bed a draft-current of air and products of combustion in condition to substantially retard the combustion, and means for adding air to the outdraft from the burner at its entrance into the furnace-chamber.

16. In combination a furnace having a combustion-chamber where the flame takes effect on the object to be heated, a coal-bed burner opening into said furnace, means for deriving and passing through the coal-bed in said burner a mixture of primary air and products of combustion in predetermined proportions in condition to substantially cool the burner, and means for supplying secondary air to the outdraft from the burner entering said combustion-chamber.

In testimony whereof I have affixed my signature in presence of two witnesses.

BYRON E. ELDRED.

Witnesses:

R. M. PIERSON,
H. L. ROBBINS.