

R. M. Dill.

Harness Tug.

N^o 106,037.

Patented Aug. 2, 1870.

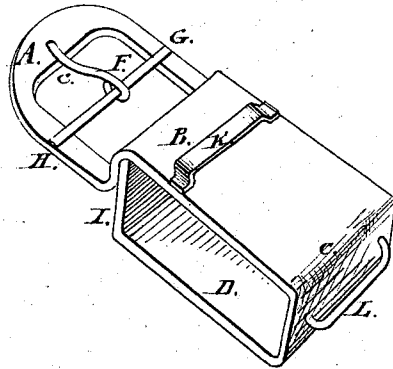

Witnesses:
Chas. Werbe
F. Hengsch

Inventor:
Richard M. Dill
per C. E. McDonald attorney.

United States Patent Office.

RICHARD M. DILL, OF MORGANTOWN, INDIANA.

Letters Patent No. 106,037, dated August 2, 1870.

IMPROVED TRACE-HOLDER FOR HARNESS.

The Schedule referred to in these Letters Patent and making part of the same.

To all whom it may concern:

Be it known that I, RICHARD M. DILL, of Morgantown, in the county of Morgan and State of Indiana, have invented an Improved Buckle; and I do hereby declare that the following is a full, clear, and exact description thereof, reference being had to the accompanying drawing and to the letters of reference marked thereon.

The nature of the invention consists in its construction of a buckle, in such a way that it will serve both as a buckle, a loop for the tug, and a loop in which to fasten the belly-band; said buckle to be made of iron or brass, or any other suitable and convenient material.

To enable others skilled in the art to make and use my said invention, I proceed to describe it more fully as follows:

A B C, of the accompanying drawing, is a perspective view of said buckle.

E F is the tongue.

A, the end plate on which the tongue rests.

G H, the cross-piece, on which the tongue is fastened.

K, the loop, through which the strap is slipped after being buckled.

L, the loop in which the belly-band is fastened

B C D, the loop through which the tug passes.

The whole frame of the buckle is cut out of a plain piece of sheet metal, and then bent up in the form represented in the drawing.

To use my said buckle, it is buckled at the breeching or the pad, in such a position that the tug will pass through it conveniently, thereby dispensing with

a common leather loop. If it be fastened to the pad, the belly-band is attached to it by the loop L, which will be found a very great improvement over the devices now in general use.

My improvement is designed chiefly as a combined buckle for the back or saddle-band, the belly-band, and a supporter for the trace or tug-strap, and is composed of a single plate bent into the form shown, into the buckle A of which the back or saddle-band is secured, and in the loop L the belly-band, while the trace or tug-strap passes through and is supported by the oblong loop D, in such manner as to allow it to move back and forth to accommodate itself to the motion of the whiffletree and the shoulders of the horse, and also serves as a means for holding up the traces when the horse is unhitched, thus avoiding the necessity of having to tie them up, and to prevent the traces from rubbing against and wearing the hair from the horse's sides.

Having described my invention,

I claim—

A buckle for the back or saddle-band, consisting of a single plate bent and formed as described, and adapted also as a loop, D, for the tug or trace, and a loop, L, for the belly-band, as herein shown and described.

In testimony that I claim the foregoing specification, I have hereunto set my hand this 19th day of January, 1869.

RICHARD M. DILL.

Witnesses:

WILL W. WALLACE,
CHAS. WERBE.