

J. B. OELKERS.
 EMBROIDERY FRAME.
 APPLICATION FILED JAN. 25, 1911.

999,847.

Patented Aug. 8, 1911.

2 SHEETS—SHEET 1.

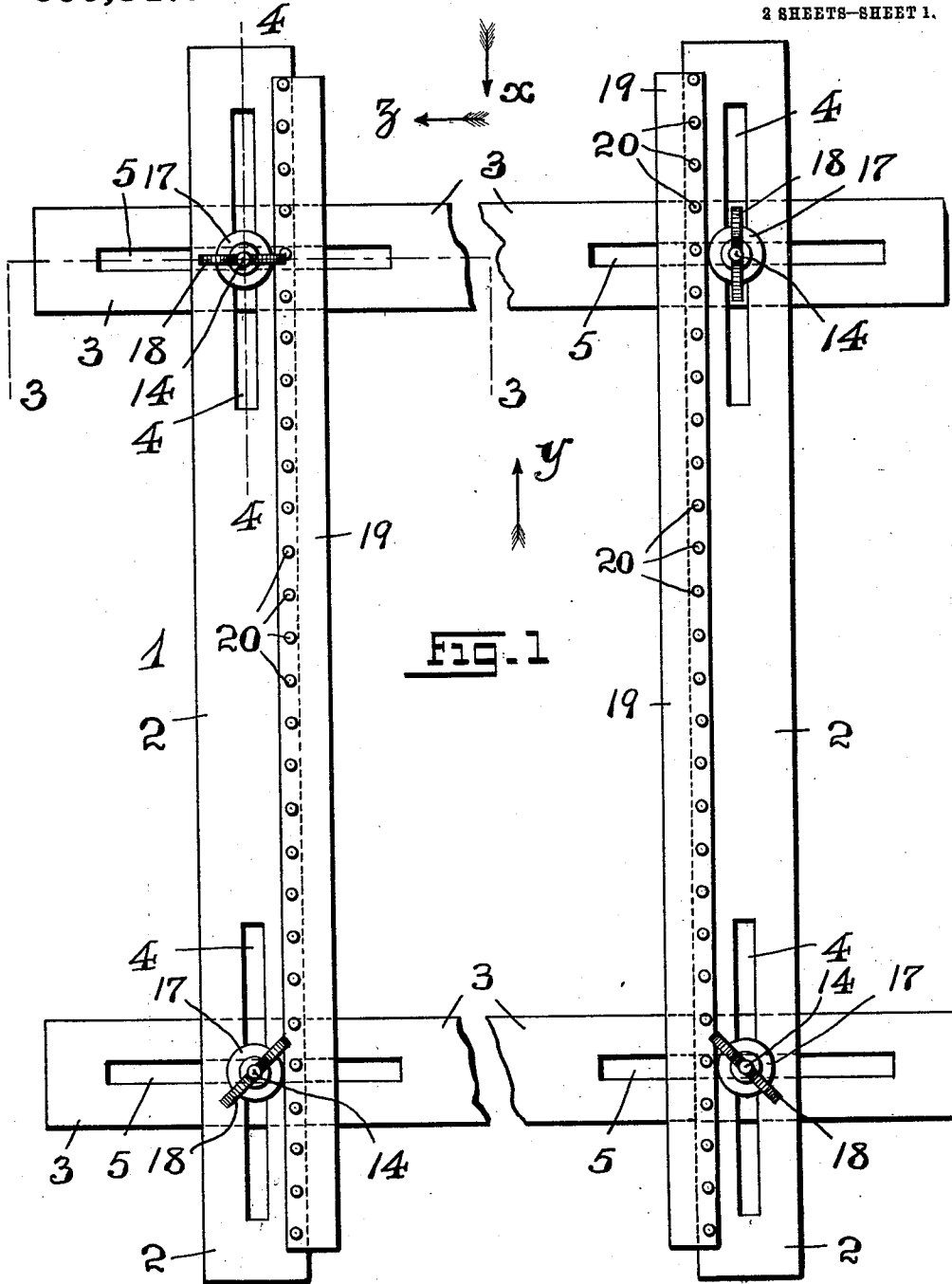

WITNESSES:
Harry C. Pfeiffer
Frank H. W. Fraumtzel

INVENTOR:
John B. Oelkers,
 BY
Fraumtzel and Richards,
 ATTORNEYS.

999,847.

Patented Aug. 8, 1911.

2 SHEETS—SHEET 2.

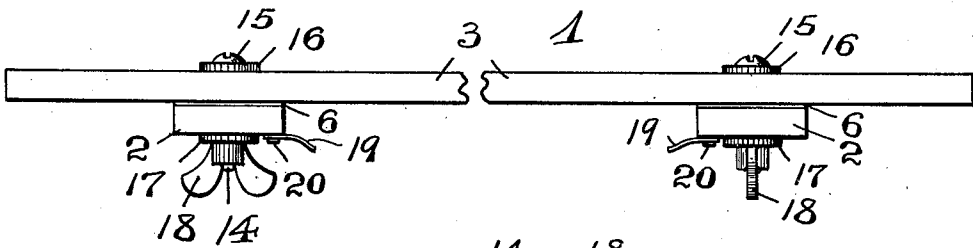

FIG. 2

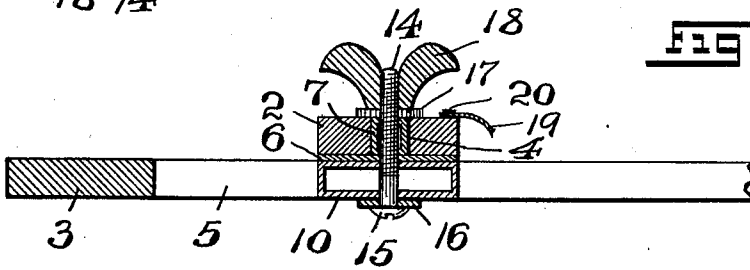

FIG. 3

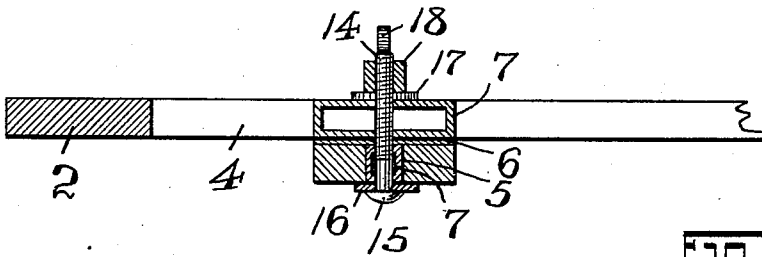

FIG. 4

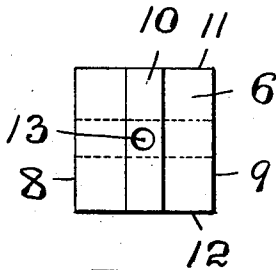

FIG. 5

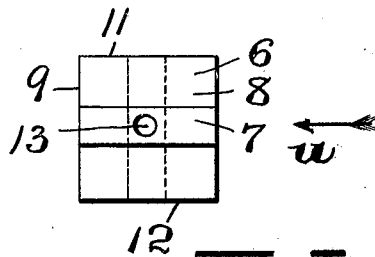

FIG. 6

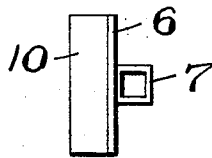

FIG. 7

WITNESSES:
Harry C. Pfeiffer
Ernest H. W. Brautzel

INVENTOR:
 John B. Oelkers,
 BY *Brautzel and Richards,*
 ATTORNEYS

UNITED STATES PATENT OFFICE.

JOHN B. OELKERS, OF NEWARK, NEW JERSEY.

EMBROIDERY-FRAME.

999,847.

Specification of Letters Patent.

Patented Aug. 8, 1911.

Application filed January 25, 1911. Serial No. 604,516.

To all whom it may concern.

Be it known that I, JOHN B. OELKERS, a citizen of the United States, residing at Newark, in the county of Essex and State of New Jersey, have invented certain new and useful Improvements in Embroidery-Frames; and I do hereby declare the following to be a full, clear, and exact description of the invention, such as will enable others skilled in the art to which it appertains to make and use the same, reference being had to the accompanying drawings, and to characters of reference marked thereon, which form a part of this specification.

This invention has reference, generally, to improvements in embroidery frames; and, the present invention relates, more particularly, to that class of embroidery frames comprising a series of adjustably connected frame-members provided with means for securing the said members after adjustment in their rigidly connected relation.

The invention has for its principal object to provide a novel and simply constructed embroidery frame comprising a series of adjustably connected frame-members or bars provided with a novel form of fastening means for securing the said frame-members or bars rigidly in their fixed relation and against any possible distortive movement.

The invention has for its further object to provide a hand-embroidery frame, the parts of which are readily assembled and secured in their rigidly fixed relations, the frame being very light so that it can be easily handled without undue exertion on the part of the person using the frame.

With these various objects in view, the present invention consists, primarily, in the novel embroidery frame hereinafter set forth; and, the invention consists, furthermore, in the novel arrangements and combinations of the various parts, as well as in the details of the construction of the same, all of which will be more fully described in the following specification, and then finally embodied in the clauses of the claim which are appended to and which form an essential part of this specification.

The invention is clearly illustrated in the accompanying drawings, in which:—

Figure 1 is a top or plan view of an embroidery frame showing one embodiment of the principles of the present invention; and Fig. 2 is an edge view of the parts repre-

sented in said Fig. 1, looking in the direction of the arrow *x*. Fig. 3 is a detail vertical section, said section being taken on line 3—3 in said Fig. 1, looking in the direction of the arrow *y*; and Fig. 4 is a similar section, taken on line 4—4 in said Fig. 1, looking in the direction of the arrow *z*. Figs. 5 and 6 are face views of the opposite sides of one of retaining blocks with which the fastening devices for adjusting the frame-members are used; and Fig. 7 is an edge view of the said block, looking in the direction of the arrow *u* in said Fig. 6.

Similar characters of reference are employed in all of the above described views, to indicate corresponding parts.

Referring now to the said figures of the drawings, the reference-character 1 indicates a complete hand-embroidery frame made according to and embodying the principles of the present invention, the said frame comprising two longitudinally extending frame-members or bars 2 and a pair of laterally extending frame-members or cross-bars 3. These several frame-members or bars are arranged in the manner generally represented in Figs. 1 to 4 inclusive, said bars being of any suitable and desired lengths and widths, the members or bars 2 being provided with suitably disposed slots or elongated openings 4, and the said members or bars 3 being provided with correspondingly placed slots or elongated openings 5, said openings 4 and 5 being of any desired length, so as to permit of any suitable adjustment of the frame-members, as will be clearly evident.

The slotted end-portions of the frame-members 2 and 3 are arranged at right angles, or approximately so, over each other, substantially in the manner shown, and the retaining device, for rigidly securing the crossed portions of the frame-members or bars 2 and 3 in their adjusted relations, consists of a plate-like element 6, upon the upper face of which is a projection or rib-like member 7 extending from the marginal edge-portion 8 and 9 of said plate-like element, and upon the opposite and lower face of which is a second projection or rib-like member 10, said last-mentioned projection or rib-like member extending from the marginal edge-portion 11 and 12 of said plate-like element 6, and at right angles to the direction of the said first-mentioned projection or rib-like member 7, all of which will be clearly

understood from an inspection of Figs. 3 to 7 inclusive of the drawings. The preferred conformation of the said projections or rib-like members is that herein shown, being
 5 rectangular in cross-section, and being preferably made hollow, as shown, although the said projections or rib-like members may be made solid, if desired. As shown, the said plate-like element 6, as well as the two pro-
 10 jections or rib-like members 7 and 10 are formed with a series of holes all in alignment with each other, see Figs. 3 and 4 of the drawings, the said registering holes all forming a bolt or screw-receiving opening
 15 13, as will be clearly evident.

In order to rigidly secure the crossed portions of the frame-members or bars 2 and 3 in the adjusted relations, the lower rib or projection 10 is slidably arranged in the
 20 elongated opening or slot 5 of the member or bar 3, with the plate 6 resting upon the upper face of said member or bar 3. The lower face of the other frame-member or bar 2 is then arranged upon the upper face
 25 of said plate 6 with the upwardly extending rib or projection 7 slidably disposed in the elongated opening or slot 4 of said member or bar 2. It will thus be evident, that the respective frame-members or bars 2 and 3
 30 are capable of independent adjustment, and that the said rectangularly shaped rib-like members or projections being disposed in the slots or elongated openings of the respective bars, in the manner hereinabove stated
 35 and as shown, will at all times cause the crossed end-portions of the bars 2 and 3 to maintain the same fixed angular relation to each other. To securely maintain the said crossed end-portions of the bars 2 and 3 in
 40 their fixed adjusted relations, and to permit of the said parts to be readjusted, a suitably formed screw or bolt, as 14, is placed in each screw-receiving opening 13, the head 15 of the screw or bolt resting against a washer 16
 45 which is placed upon the shank of the screw or bolt and against the lower face of the bar 3 and the exposed face of the projection or rib 10. The screw-threaded portion of the said screw or bolt 14 extends above
 50 the upper exposed face of the projection or rib 7, a washer 17 being arranged upon this portion of the screw or bolt, and the said washer being placed upon the upper exposed face of said projection or rib 7 and upon the
 55 upper face of the frame-member or bar 2. A suitable nut, preferably a thumb-nut, as 18, is screwed down upon the screw-threaded portion of the screw or bolt 14, until firmly screwed home upon the washer
 60 17, whereby the assembled parts are rigidly secured in their fixed relation, as will be clearly evident.

From an inspection of Fig. 1 of the drawings, it will be seen that the four corner-
 65 portions of the crossed frame-members or

bars 2 and 3 are thus connected and may be rigidly and adjustably secured with relation to each other in the manner hereinabove described; and, whereby the several frame-members or bars 2 and 3 are oper-
 70 atively connected so as to provide an embroidery frame, which will not become distorted when in use, the respective members or bars 2 and 3 always maintaining their fixed angular relation, so that they will not
 75 wobble with relation to each other.

As shown in Figs. 1, 2 and 3 of the drawings, the frame-members or bars 2 are provided upon their upper faces and along the longitudinally extending marginal edge-
 80 portion which are opposed to each other with strips of flexible fabric, as 19, which are secured in place by means of tacks 20, or other suitable fastening means, to which strips the piece of work which is to be emb-
 85 broidered is fastened by being sewed thereto, or in any other suitable and well-known manner.

I am aware that some changes may be made in the general arrangements and combinations of the several parts, as well as in the details of the construction of the same without departing from the scope of the present invention as set forth in the forego-
 90 ing specification and as defined in the claims which are appended thereto. Hence, I do not limit my present invention to the exact arrangements and combinations of the parts as described in the said specification, nor do I confine myself to the exact details of the
 95 construction of the said parts, as illustrated in the accompanying drawings. 100

I claim:—

1. An embroidery frame comprising a number of adjustably connected frame-
 105 members or bars having slotted end-portions, the slotted end-portions of said bars being angularly crossed, and means connected with the crossed end-portions of said bars for adjustably connecting said end-
 110 portions consisting of a plate-like element disposed between the crossed portions of said bars, projections projecting from the opposite faces of said plate-like element, each projection extending into the
 115 slotted part of the end-portions of said bars and being slidably disposed therein, said plate-like element and its projections being formed with a screw-receiving opening, a tightening screw in said opening, a head on
 120 one end-portion of said screw, and a tightening nut upon the screw-threaded shank of said screw for securing the assembled parts after adjustment in fixed relation.

2. An embroidery frame comprising a
 125 number of adjustably connected frame-members or bars having slotted end-portions, the slotted end-portions of said bars being angularly crossed, and means connected with the
 130 crossed end-portions of said bars for ad-

justably connecting said end-portions consisting of a plate-like element disposed between the crossed portions of said bars, rectangularly formed projections projecting
5 from the upper and lower faces of said plate-like element, said projections being arranged at right angles to each other, and each projection extending into the slotted part of the end-portions of said bars and being slidably
10 disposed therein, said plate-like element and its projections being formed with a screw-receiving opening, a tightening screw in said

opening, a head on one end-portion of said screw, and a tightening nut upon the screw-threaded shank of said screw for securing
15 the assembled parts after adjustment in fixed relation.

In testimony, that I claim the invention set forth above I have hereunto set my hand this 23rd day of January, 1911.

JOHN B. OELKERS.

Witnesses:

FREDK. C. FRAENTZEL,

FREDK. H. W. FRAENTZEL.

Copies of this patent may be obtained for five cents each, by addressing the "Commissioner of Patents, Washington, D. C."
