

F. S. CRABTREE.
 DOOR LOCKING DEVICE.
 APPLICATION FILED APR. 11, 1910.

975,122.

Patented Nov. 8, 1910.

Fig. 1.

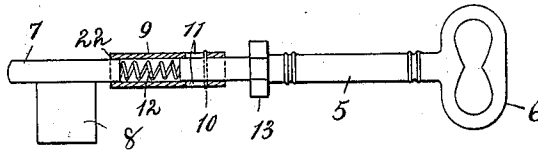

Fig. 2.

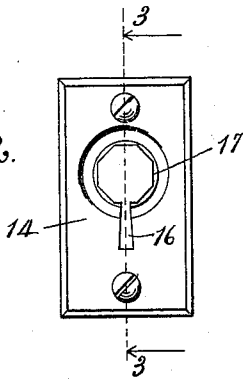

Fig. 3.

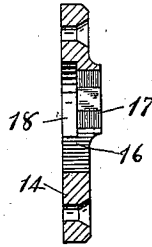
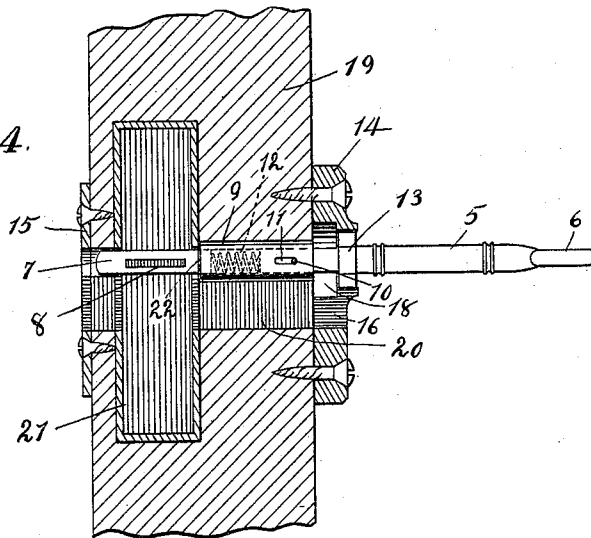

Fig. 4.



Witnesses
 Char. J. Bassett
 M. A. Milord

Inventor
F. S. Crabtree
 By *Jedediah P. Piquette*
 Attorney

UNITED STATES PATENT OFFICE.

FRANK S. CRABTREE, OF NORTH LEEDS, MAINE.

DOOR-LOCKING DEVICE.

975,122.

Specification of Letters Patent.

Patented Nov. 8, 1910.

Application filed April 11, 1910. Serial No. 554,657.

To all whom it may concern:

Be it known that I, FRANK S. CRABTREE, citizen of the United States, residing at North Leeds, in the county of Androscoggin and State of Maine, have invented certain new and useful Improvements in Door-Locking Devices, of which the following is a specification.

My invention relates to door locking devices and refers especially to means for preventing a lock key from being turned from the outside of the door when left in the lock, the particular parts to which the improvements constituting the subject matter of this application are directed, being the key and escutcheon plate, and the chief objects of said improvements are to provide a simple, efficient and practical means for locking the key in an inoperative position, thereby preventing it from being turned by the use of tools applied at or through the key hole upon the other side of the door, or removed from the lock by any manipulation from the side opposite to that of the insertion of the key.

In order to accomplish the desired results, I employ a key formed in two sections adapted to be relatively extended and retracted and normally retained in extended relation by a suitable spring arranged between said sections, and a cooperating escutcheon or key-hole plate of novel construction and adapted to be engaged by a squared portion of the key when the latter is in the lock.

The details of construction of my improved key-fastener are fully disclosed in the accompanying drawing which forms a part of this application, the views being as follows:—

Figure 1 is a side elevation of my improved key with the telescoping sleeve in section; Fig. 2 is an elevational view of the key cooperating escutcheon; Fig. 3 is a cross-sectional view on the line 3—3 of Fig. 2, and Fig. 4 is a vertical section through a door and lock showing the key in locked position, only a portion of the door and a lock-case being shown.

Referring to the details of the drawing, the numeral 5 indicates the stem of a key furnished with the usual handle or bow 6. The pin 7, carrying the bit 8, is separate from the said stem, but has a slidable connection therewith by a sleeve 9 suitably secured to the said pin, but adapted to have

a sliding fit upon the end of the stem to which it is secured by a retaining pin 10, fitting tightly in the stem and having both ends projecting into slots 11 in the sleeve to permit the required longitudinal movement while preventing any rotatory movement. A spring 12 is arranged in the said sleeve between the inner end of the stem 5 and the inner end of the pin 7, and holds the parts in extended relation as shown in Fig. 1. Upon the stem 5 of the key is mounted a fixed nut 13, preferably octagonal in shape as shown. A cooperating escutcheon or key-hole plate 14 is arranged upon the inner side of the door. This plate differs from the outside escutcheon 15 by being made comparatively heavier and furnished with a key-hole of special shape. The lower portion of the hole is made in the usual slot form to admit the bit 8, while the upper portion of the key hole which is usually round, is in this instance made octagonal as shown at 17, to correspond with the shape of the fixed nut 13 carried by the stem 5. The inner face of the plate 14 is provided with a circular recess 18, concentric with the octagonal hole 17 and of somewhat larger diameter. If the parts are properly fitted, the nut 13 will turn freely when in the said recess 18, but when engaging the walls of the octagonal hole 17, the escutcheon will act as a chuck or lock-nut to prevent the key from being turned. In Fig. 4 the door 19 is pierced with a key-way so furnished with a mortise lock 21, the casing only of which is shown, since the mechanism of the lock has no bearing upon the present invention.

The device is operated in the following manner: The key is placed in the key hole of the escutcheon 14 and slid through the key way 20 until the pin and bit enter the lock casing and the end or shoulder 22 of the connecting sleeve 9 engages the face of the lock-casing and prevents further longitudinal movement of the key. When the key is in this position the nut 13 will engage the squared hole or socket 17 and the key be locked against turning. By pressing the stem of the key inward, however, the stem 5 will slide in the sleeve 9, compressing the spring 12 and carrying the nut 13 into the recess 18. The key may now be turned freely and thus operate the lock, care being taken to continue sufficient pressure endwise upon the stem to prevent the said spring

from returning the nut to its engaging or locked position. As soon as the bit has been turned to aline with the key-way 20, the pressure may be removed from the stem, when the spring 12 will again extend the parts and as the bit lies in the key-way 16, the key may now be withdrawn if desired. It will be understood that when the key is inserted from the outside through the key hole plate 15, it may be used in the same manner as an ordinary key, since there will be no hindrance to the turning of the nut 13.

The foregoing description refers to the ordinary function of the key. In order to secure the key in the lock in such a way as to prevent any tampering therewith from the outside it is only necessary to insert the key through the escutcheon 14 until the bit enters the lock, as previously explained, press the stem inwardly as before to cause the nut to enter the recess 18. The key is now turned to the required position and the stem released, when the nut 13 will enter the octagonal socket under the action of the spring 12, as before, but as the bit 8 is turned to some position out of alinement with the key way, the key will be positively secured in the lock and can be released only by manipulation from the inside of the door.

Having thus described my invention what I claim as new is—

1. Key fastening means comprising a key formed in two sections, a spring normally holding said sections in extended relation, a sleeve embracing said sections, a squared member on one of the key sections, and an escutcheon plate adapted to engage said member when the key is in operative position without pressure and to release said

member when the key is subjected to pressure.

2. Key fastening means, comprising a key formed in two sections, a spring normally holding said sections in extended relation, means slidably connecting said sections, a squared portion on the key, a key-hole plate adapted to be attached to a door, and a socket in the plate adapted to engage the squared portion of the key when the latter is applied to the lock without pressure, and to release said portion when inward pressure is exerted on the key.

3. Key fastening means, comprising a key formed in two sections slidably connected, a spring normally holding the said sections extended, a fixed nut attached to one of the sections, and means engaging said nut to prevent the turning of the key.

4. Key fastening means, comprising a key made in two sections one of said sections having the bit, and the other the bow portion, a sleeve secured to one of said sections and slidably engaging the other section, a spring arranged in said sleeve and normally holding said sections in extended rotation, means for limiting the extensibility of sections, an escutcheon having an opening and a recess therein and means on said key adapted to normally engage said opening and thereby prevent the turning of the key, and to enter said recess and thereby permit the turning of the key.

In testimony whereof I affix my signature in the presence of two witnesses.

FRANK S. CRABTREE.

Witnesses:

OLIVER J. FOSS,
W. J. DAGGETT.