



(86) Date de dépôt PCT/PCT Filing Date: 2003/11/18
 (87) Date publication PCT/PCT Publication Date: 2004/06/03
 (45) Date de délivrance/Issue Date: 2013/01/15
 (85) Entrée phase nationale/National Entry: 2005/05/18
 (86) N° demande PCT/PCT Application No.: AU 2003/001638
 (87) N° publication PCT/PCT Publication No.: 2004/045875
 (30) Priorité/Priority: 2002/11/18 (AU2002 952 723)

(51) Cl.Int./Int.Cl. *B60C 23/04* (2006.01)
 (72) Inventeur/Inventor:
 COHEN, PHILLIP ALBERT, AU
 (73) Propriétaires/Owners:
 COHEN, PHILLIP ALBERT, AU;
 MANGAFAS, NICHOLAS, AU
 (74) Agent: GOWLING LAFLEUR HENDERSON LLP

(54) Titre : AMELIORATIONS APORTEES A DES SYSTEMES DE CONTROLE DES DONNEES DE PNEUMATIQUES
 (54) Title: IMPROVEMENTS IN TYRE DATA MONITORING SYSTEMS

SYSTEM BLOCK DIAGRAM

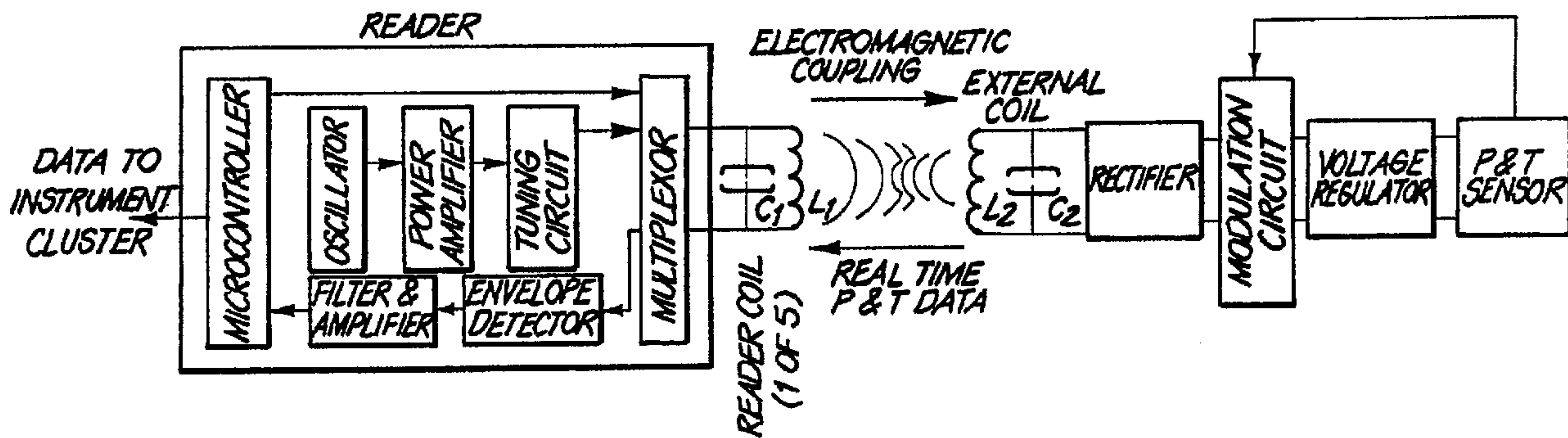

(57) **Abrégé/Abstract:**

A vehicle tyre data monitoring system has a wheel mounted sensor means that is adapted to transmit one or more of pressure, temperature, angular velocity, and force vector data for a tyre as a digital serial datagram through a two-wire communication channel to a chassis mounted reader means. The communication channel is adapted to simultaneously supply power to the sensor means and receive the data for processing and subsequent display to a user of the system.

(12) INTERNATIONAL APPLICATION PUBLISHED UNDER THE PATENT COOPERATION TREATY (PCT)

(19) World Intellectual Property
Organization
International Bureau



(43) International Publication Date
3 June 2004 (03.06.2004)

PCT

(10) International Publication Number
WO 2004/045875 A1

(51) International Patent Classification⁷: **B60C 23/04**

(21) International Application Number:
PCT/AU2003/001638

(22) International Filing Date:
18 November 2003 (18.11.2003)

(25) Filing Language: English

(26) Publication Language: English

(30) Priority Data:
2002 952 723 18 November 2002 (18.11.2002) AU

(71) Applicant and

(72) Inventor: **COHEN, Phillip, Albert** [AU/AU]; 8 Adair Place, Killara, New South Wales 2072 (AU).

(72) Inventor; and

(75) Inventor/Applicant (for US only): **MANGAFAS, Nicholas** [AU/AU]; Level 18, Pacific Power Building, 201 Elizabeth Street, Sydney, New South Wales 2000 (AU).

(74) Agent: **MAXWELL, Peter, Francis**; Peter Maxwell & Associates, Level 6, 60 Pitt Street, SYDNEY, New South Wales 2000 (AU).

(81) Designated States (*national*): AE, AG, AL, AM, AT, AU, AZ, BA, BB, BG, BR, BW, BY, BZ, CA, CH, CN, CO, CR, CU, CZ, DE, DK, DM, DZ, EC, EE, EG, ES, FI, GB, GD, GE, GH, GM, HR, HU, ID, IL, IN, IS, JP, KE, KG, KP, KR, KZ, LC, LK, LR, LS, LT, LU, LV, MA, MD, MG, MK, MN, MW, MX, MZ, NI, NO, NZ, OM, PG, PH, PL, PT, RO, RU, SC, SD, SE, SG, SK, SL, SY, TJ, TM, TN, TR, TT, TZ, UA, UG, US, UZ, VC, VN, YU, ZA, ZM, ZW.

(84) Designated States (*regional*): ARIPO patent (BW, GH, GM, KE, LS, MW, MZ, SD, SL, SZ, TZ, UG, ZM, ZW), Eurasian patent (AM, AZ, BY, KG, KZ, MD, RU, TJ, TM), European patent (AT, BE, BG, CH, CY, CZ, DE, DK, EE, ES, FI, FR, GB, GR, HU, IE, IT, LU, MC, NL, PT, RO, SE, SI, SK, TR), OAPI patent (BF, BJ, CF, CG, CI, CM, GA, GN, GQ, GW, ML, MR, NE, SN, TD, TG).

Published:

— with international search report

For two-letter codes and other abbreviations, refer to the "Guidance Notes on Codes and Abbreviations" appearing at the beginning of each regular issue of the PCT Gazette.

(54) Title: IMPROVEMENTS IN TYRE DATA MONITORING SYSTEMS

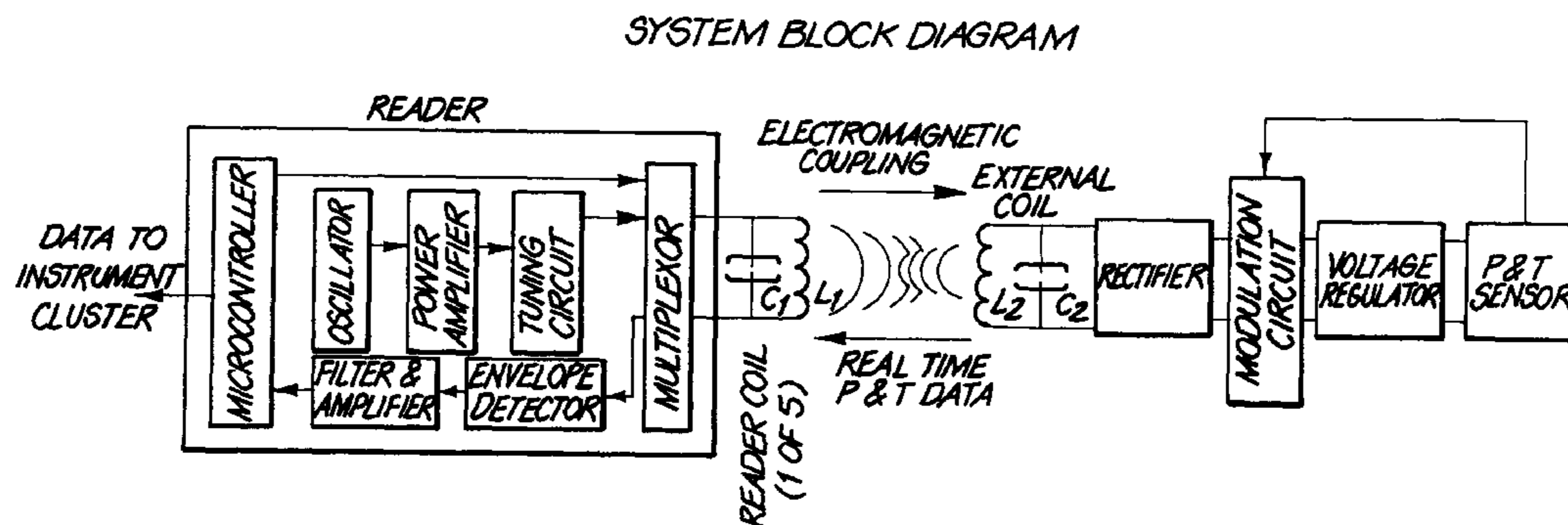

(57) Abstract: A vehicle tyre data monitoring system has a wheel mounted sensor means that is adapted to transmit one or more of pressure, temperature, angular velocity, and force vector data for a tyre as a digital serial datagram through a two-wire communication channel to a chassis mounted reader means. The communication channel is adapted to simultaneously supply power to the sensor means and receive the data for processing and subsequent display to a user of the system.

WO 2004/045875 A1

IMPROVEMENTS IN TYRE DATA MONITORING SYSTEMSFIELD OF THE INVENTION

The present invention relates to vehicle tyre data monitoring systems
5 and, more particularly, to a two-wire communication channel between a
vehicle's wheel mounted sensor means and chassis mounted reader or
receiving means.

BACKGROUND OF THE INVENTION

There are two types of tyre pressure monitoring systems (TPMS)
10 currently available which alert a vehicle's driver to abnormal tyre pressure
conditions: direct measurement systems and indirect measurement systems.
A direct measurement system measures tyre pressure directly with physical
pressure sensors. Indirect measurement systems measure something other
than actual tyre pressure, such as relative wheel angular velocities or axle to
15 road height changes.

The class of direct measurement systems can be further categorized
according to the means employed to provide power to the sensor and
implement the communication channel between a vehicle's wheel mounted
sensor means and chassis mounted receiving means. Notwithstanding power
20 supply difficulties, just getting the signals off electrical sensors that are
mounted inside the rotating wheels presents a serious problem. The prior art
approach typically involved wheel mounted, battery powered radio frequency
(RF) transmitter modules which continue to suffer from system limitations and
reliability problems.

25 Limitations of battery powered RF transmitter modules include:

- dependence on battery power sources inside the tyre (Once batteries are depleted, operation is compromised and replacement is costly);
- in order to conserve battery power, continuous monitoring is not possible, (Transmission of sensed information takes place only when a pressure activation floor is passed (non-deterministic transmission algorithm));
- difficulties identifying tyre positions after tyres undergo rotation schedules (Usually, tyre positions must be manually reprogrammed);
- cross-talk between other adjacent vehicles with active transmitters and receivers;
- the receiver's electronics being subject to deafening by spurious energy fields from external sources (e.g., television transmitters, garage door openers and CB radios etc.); and
- being affected adversely by the influence of metallic vehicle parts on energy field density patterns in the vicinity of the receiver antennae.

The performance of the aforementioned prior art approach varies greatly between vehicle models because every vehicle model has a different geometry that may interfere adversely with energy field densities.

In contrast, the present invention is based on the direct measurement TPMS approach which employs a two-wire communication channel between wheel mounted sensors and chassis mounted receiver electronics. Importantly, this approach obviates the need for sensor batteries inside the tyre, can use the minimum number of physical conductors (two), is economical and has a highly predictable and reliable performance.

The object of the present invention is to provide an economical and highly reliable system to alert the driver of a vehicle to any abnormal

pressures, temperatures, angular velocities or force vectors which may exist in any or all of the vehicle's tyres (including the spare tyre) under all driving or stationary conditions. The system is deterministic and is not affected by tyre replacement, tyre rotations, or deafening of the receiver
5 electronics by radio frequency interference.

SUMMARY OF THE INVENTION

The present invention is directed to a system that provides power to a wheel mounted sensor means so as to perform measurement of tyre pressure, temperature, angular velocity or force vector data. The system
10 provides the means for the subsequent transmission of this data to chassis mounted reader means comprising receiving means mounted on a non-rotating component of a hub for the wheel and to display subsystems. Normal and abnormal operating pressure and temperature information, for example, of a vehicle's pneumatic tyres are then available to a vehicle's
15 driver.

According to the invention, there is provided a vehicle tyre data monitoring system comprising a wheel mounted sensor means adapted to transmit one or more of pressure, temperature, angular velocity, and force vector data for a tyre as a digital serial datagram through a two-wire,
20 electromagnetically coupled, communication channel to a chassis mounted reader means, the communication channel comprising electromagnetic coupling means adapted to have constant mutual inductance and to simultaneously supply power to the sensor means and receive the data for processing and subsequent display to a user of the system.

25 Preferably, the sensor means comprises a three or more terminal sensor subsystem having at least separate ground, power and data connections which is converted to a two terminal sensor subsystem for transmitting the data

across the communication channel to the reader means, with a first terminal being for a ground reference connection and a second terminal being for a combined power and data connection.

It is preferred that the two-wire communication channel superimposes the transmission of the data on the power connection as a serial datagram that is received by the receiving means.

Also preferably, the datagram is decoded by the reader means to provide decoded information that is made available to a microprocessor system for analysis and display of the tyre data to a user of the system.

In a first form of the invention, there is provided a two-wire communication channel for a vehicle tyre data monitoring system, the channel including electromagnetic coupling means between a sensor means mounted on a wheel of the vehicle and a reader means mounted on a chassis of the vehicle, and being adapted to transmit one or more of pressure, temperature, angular velocity and force vector data for a tyre as a digital serial datagram from the sensor means to the reader means and to supply power from the reader means to the sensor means, the supply of power being simultaneous with the transmission and reception of the data, wherein the electromagnetic coupling means includes a first part mounted on a rotatable rim for the wheel and a second part mounted on a non-rotating component of a hub for the wheel, the first part and the second part being adapted to maintain a constant mutual inductance therebetween during complete rotation of the wheel, the first and second parts providing a non-contacting, two wire communication channel for the data monitoring system.

In accordance with the above first form of the invention, there is provided an electromagnetic coupling in a two-wire communication channel for a vehicle tyre data monitoring system, the electromagnetic coupling comprising

a first part mounted on a rotatable rim of a wheel of the vehicle, and a second part mounted on a non-rotating component of a hub for the wheel, the first part and the second part being adapted to maintain constant mutual inductance therebetween during complete rotation of the wheel for the transmission of
5 decodable data for the tyre from a sensor means mounted on the wheel to a reader means mounted on the chassis.

Further in accordance with the above first form of the invention, there is provided a vehicle wheel to hub electromagnetic coupling interconnection in a tyre data monitoring system for the transmission
10 thereacross of one or more of pressure, temperature, angular velocity and force vector data for a tyre mounted on the wheel, the electromagnetic coupling interconnection comprising a first part mounted on a rotatable rim of the wheel and adapted to receive the data from a sensor means, and a second part
15 mounted on a non-rotating component of a hub for the wheel, the second part being adapted to maintain a constant air gap distance with the first part when the wheel is mounted on the hub so as to maintain constant mutual inductance between the first part and the second part for allowing the data to be transmitted from the first part to the second part, the second part being further adapted to transmit the data to a reader means mounted on a chassis of the
20 vehicle for processing and subsequent display to a user of the system.

Preferably, the constant air gap distance between the first part and the second part is maintained after each mounting of the wheel on the hub.

In a preferred form of the invention, there is provided a two-wire communication channel for a vehicle tyre data monitoring system, the
25 channel including electromagnetic transforming means for communicating between a sensor means mounted on a wheel of the vehicle and a reader means mounted on a chassis of the vehicle, and being adapted to transmit

5a

one or more of pressure, temperature, angular velocity and force vector data for a tyre as a digital serial datagram from the sensor means to the reader means and to supply power from the reader means to the sensor

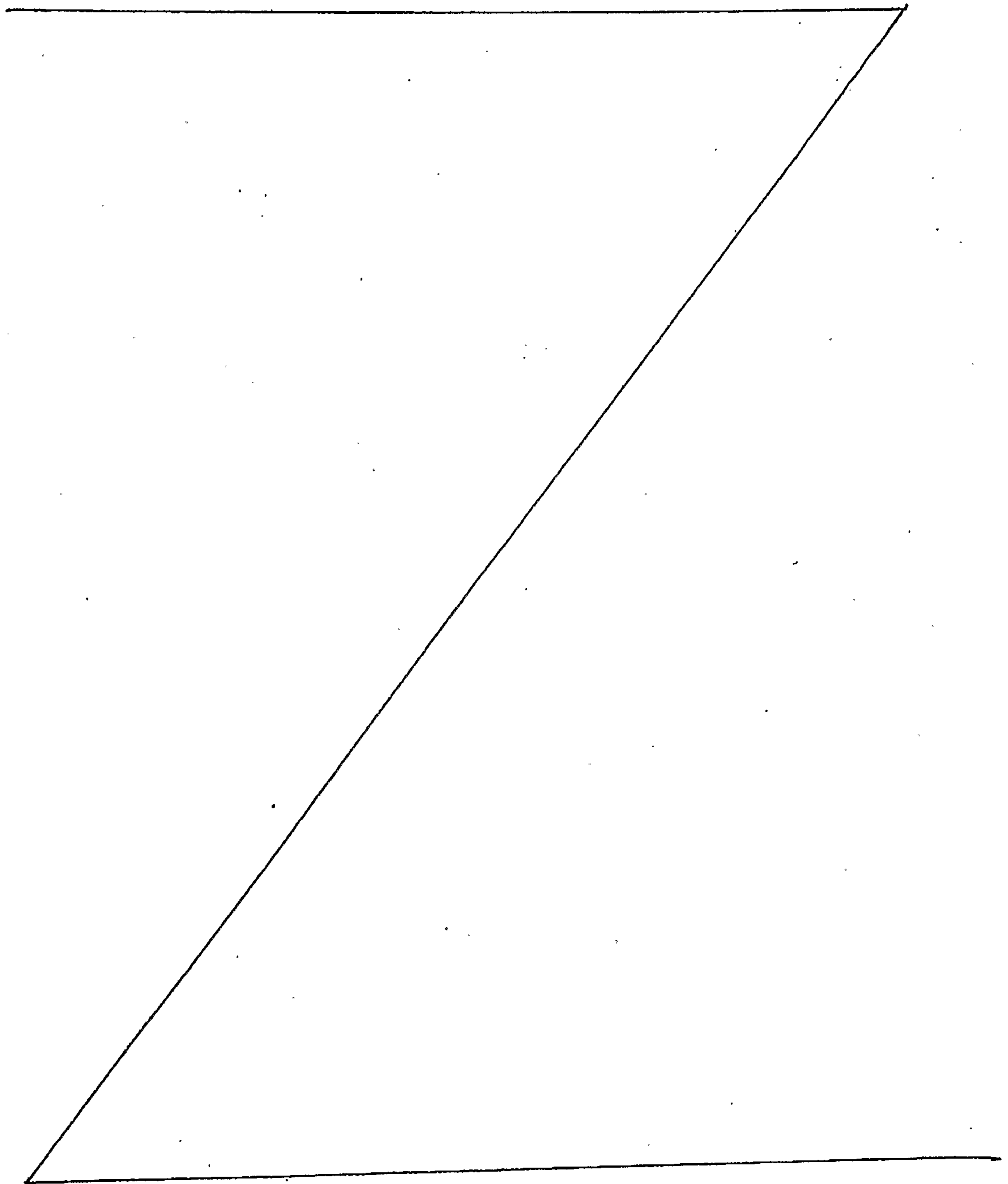

means, the supply of power being simultaneous with the transmission and reception of the data, wherein a first part of the electromagnetic transforming means is mounted annularly on a rim of the wheel and a second part of the electromagnetic transforming means is mounted on a non-rotating component of a hub for the wheel, the first and second parts being divided by an air gap and providing a non-contacting, constant mutual inductance, electromagnetically coupled, two wire communication channel for the data monitoring system.

Preferably, the second part comprises a receiver coil mounted on a non-rotating component of a hub for the wheel, such as on a mounting bracket for a brake caliper, and the first part comprises a sensor coil so mounted annularly on the rim of the wheel as to maintain a sufficiently proximate air gap distance to, and a constant mutual inductance with, the receiver coil during rotation of the wheel for electromagnetic induction to occur. Preferably, the air gap distance remains constant at all times whether stationary or during rotation of the wheel.

Preferably, the sensor coil includes a power supply circuit and derives power to operate the sensing and transmission of the data from an electromagnetic flux generated by the receiver coil serving as a power connection, the electromagnetic flux causing the power supply circuit of the sensor coil to develop sufficient DC voltage to enable the sensor means to be energised and to transmit the data to the reader means, the data being adapted to modulate the electromagnetic flux so as to superimpose the transmission of the data on the power connection as a serial datagram, the so modulated signal being detected, filtered, amplified and decoded by the reader means to enable the data to be processed and displayed to a user of the system.

Receiver interface electronics in the chassis mounted reader means extracts the power connection's superimposed serial data. The reader means includes an envelope detector, and a filter and amplifier means. A microprocessor system in the module analyses the recovered data for
5 abnormal conditions. The reader module preferably has further interface options that are suitable for connection to various known motor vehicle body electronics systems. These interface options include the Bosch™ Controller Area Network (CAN) bus, the General Motors™ LAN bus, RS232 serial port and "Tell Tale" warning light with audible alarm.

10 SUMMARY OF THE DRAWINGS

- Fig. 1 is a side view of a two-terminal sensor subsystem stud mounting encapsulation package used in a preferred embodiment of a first form of the invention,
Fig. 2 is a sectional view through 1-1 of the stud mounting
15 encapsulation package shown in Fig. 1,
Fig. 3 is a top view of the package shown in Fig. 1,
Fig. 4 is a bottom view of the package shown in Fig. 1,
Fig. 5 is a diagram of a tyre valve receptacle insulated electrode
used to connect a sensor to the external face of the wheel
20 rim in one embodiment of the invention,
Fig. 6 is a circuit diagram of an inductively coupled circuit that illustrates an underlying relationship of factors involved in mutual inductance,
Fig. 7 is a circuit diagram of an equivalent T-circuit that illustrates
25 another underlying relationship of factors involved in mutual inductance,

- Fig. 8 is a diagram of a preferred two-wire communication channel for a vehicle tyre data monitoring system according to one form of the invention, showing an arrangement of primary and secondary inductance coils,
- 5 Fig. 9 is a diagram of an electromagnetically coupled system according to a first preferred embodiment of the invention,
- Fig. 10 is a diagram of an electromagnetically coupled system according to a second preferred embodiment of the invention which uses the electrode of Fig 5,
- 10 Fig. 11 is a diagram showing the preferred angular and distance relationships between various system components of a preferred form of the invention,
- Fig. 12 is a summary block diagram of preferred circuit components of a preferred form of the invention,
- 15 Fig. 13 is a diagram of a circuit for a first preferred sensor means used in a preferred form of the invention,
- Fig. 14 is a diagram of a circuit for a second preferred sensor means used in a preferred form of the invention,
- Fig. 15 is a diagram showing signal waveforms typical of an electromagnetically coupled arrangement of a preferred form of the invention,
- 20 Fig. 16 is a diagram of a preferred electromagnetically coupled system according to a second form of the invention.
- Fig. 17 is a diagram showing a preferred arrangement for mounting a reader coil assembly on a brake caliper mounting bracket,
- 25

Fig. 18 is a side view of a two-terminal sensor subsystem stud mounting encapsulation package used in a preferred embodiment of the second form of the invention,

5 Fig. 19 is a section view through 18-18 of the stud mounting encapsulation package shown in Fig. 18, when mounted through the wheel rim,

Fig. 20 is a top view of the package shown in Fig. 18, and

Fig. 21 is a bottom view of the package shown in Fig. 18.

DETAILED DESCRIPTION OF PREFERRED EMBODIMENTS OF THE

10 INVENTION

1. **Sensor Subsystem Interface for Electromagnetically Coupled System.**

Industry standard three terminal (Ground, Power and Data) pressure sensor subsystems are available which have a digital asynchronous serial data transmission output. They have a recommended power supply of
15 between 2.5 and 3.6 Volts, a current consumption of typically 12 micro Amps, and operate over a temperature range of - 40 to + 125 degrees Centigrade.

Figs. 13 and 14 show three-terminal sensor subsystems having connections of Ground, Power (3.3Volts) and Asynchronous Serial Data
20 Output. Power is supplied to the sensor subsystems via a low noise, low voltage drop out, zero capacitor type voltage regulator ($V_{in} = 3.9 - 5.0$ Volts, $V_{out} = 3.3$ Volts) with specifications as follows:

25	Process:	CMOS
	Maximum Input Voltage:	5.5 V
	Output Voltage:	3.3 V
	Drop out voltage @ 50 mA:	55 mV
	Operating Current @ no-load:	85 μ A

10

	Operating Current @ 50 mA:	150 μ A
	Input Capacitor:	None
	Output Capacitor:	None
	Output noise @ 100 KHz:	30 μ Vrms
5	Accuracy:	2.0 %
	Line Regulation:	0.1 %/V max
	Load Regulation:	0.02 % max

2. Two-Wire Communication Channels for Electromagnetically Coupled System.

The two-wire communication channel described herein converts each three terminal (Ground, Power and Data) sensor subsystem to a two-terminal device requiring one connection to the sensor power supply electronics ground reference and the other connection to facilitate a simultaneous power with superimposed data signal to the chassis mounted electronics interface. Standard semiconductor foundry processes may be applied to replace the discrete electronics of the two-terminal sensor subsystem with a single monolithic integrated circuit encapsulated within an industry standard package, such as TO-220 standard or a stud design as shown in Figs 1 to 4.

The stud design of Figs 1 to 4 comprises a stainless steel case 12, thread 14 for a lock nut (with neoprene seal and washer), epoxy resin 16, air vent 18 to sensor diaphragm, a two-terminal monolithic integrated circuit pressure and temperature sensor subsystem 20, a ground connection 22 from the sensor subsystem 20 to the case 12, and a power/data electrode 24 from the sensor subsystem 20.

When a TO-220 case is used to encapsulate the two-terminal sensor (such as is shown in Fig. 5), its ground terminal is electrically connected to a suitable nut which is welded to the wheel rim's inside surface at a position of minimum diameter and adjacent to the valve stem receptacle.

5 Referring specifically to Fig. 5, the rubber valve stem receptacle 26 has an internal brass ferrule 28, to the top of which is connected a brass lock nut 30, a brass eyelet connector 32 to ground, and a valve extender 34 for receiving a metal dust cap 36. The power/data brass eyelet connector 38 of the two-terminal sensor subsystem 40 is electrically connected to the

10 bottom of the internal brass ferrule 28 of the valve stem receptacle 26 using an M4 threaded stainless steel cap screw 42, stainless steel locking washer 44 and cylindrical brass spacer 46. The M4 cap screw 42 has a 2mm diameter axial hole 48 to allow for the passage of air during inflation and deflation procedures. According to this arrangement, the valve

15 receptacle 26 now has dual functions of valve and insulated electrical terminal. The valve's ferrule electrically connects the wheel's internal two-terminal sensor subsystem's power/data signal to the wheel's outward facing external environment. An electrical connection between the valve receptacle's external brass ferrule 28 and the diode bridge (D2,D3) shown

20 in Fig. 14 is facilitated. The electrical connection may be made using a single insulated wire or a flexible mylar insulated single track printed circuit applied directly to the wheel rim. Electrical ground connection is via the metal of the wheel rim.

Alternately, when the stud design of Figs. 1 to 4 is used to

25 encapsulate the two-terminal sensor, it is mounted on the inside of the wheel rim via a hole located at a position of minimum wheel rim diameter. According to this arrangement, the wheel's internal two-terminal sensor

subsystem's power/data signal is made available to the wheel's inward facing external environment. An electrical connection between the stud's insulated Power / Data pin and a wheel to hub electrical mating system is facilitated. The electrical connection may be made using a single insulated
5 wire or a flexible mylar insulated single conductor track printed circuit applied directly to the wheel rim. Electrical ground connection is via the metal of the wheel rim.

The wheel to hub electromagnetically coupled system allows the wheels to be removed and replaced in the standard manner whilst
10 simultaneously providing a transmission path for the sensor subsystem's ground and power/data connections whilst *in situ*.

The use of a Cyclic Redundancy Checking (CRC) algorithm applied to the sensor subsystem's serial datagram enables the overall system to cope with any noise introduced into the communication channel.

15 **3. Electromagnetically Coupled System.**

A preferred tyre pressure monitoring system of the invention will now be described which is based on passive (no local battery) two terminal sensor elements and non-contact transmission of power and data across a vehicle's rotating wheel chassis boundary.

20 A magnetic field is employed to couple energy from a reader coil to electrically isolated sensor elements located within each wheel. This form of magnetic or inductive coupling is technically referred to as "an inductively coupled two port circuit" or in practical terms and more simply as a transformer. The reader coil is the transformer's primary winding and
25 the sensor coil is the secondary winding, both in close proximity and separated by a constant air gap. For purposes of analysis, all the conventional methods of transformer theory apply in terms of using mutual

and self inductance to determine the various current and voltage relationships. Referring to Fig 6 and Fig 7 there are three significant relationships that apply and are exploited by this invention:

- 1) The "primary" voltage is the sum of the $I_1 Z_1$ voltage drop and the voltage induced in the primary by the "secondary" current, I_2 .
- 2) The magnitude and sign of mutual inductance M depend on the proximity and the orientation of the primary and secondary coils with respect to one another but remain constant with fixed positions (position parameters are indicated in Fig 11).
- 3) At resonance the secondary impedance is a relatively low resistance but the impedance coupled into the primary as seen looking into the primary, is a relatively high resistance.

15

Referring to Fig 8, Fig 9, Fig 10 and Fig 11, the physical arrangement of primary and secondary coils maintains a constant relative position between the two coils at all times whether the wheel is rotating or stationary. This results in the transformer's flux linkage being constant at all times due to a constant air gap distance and thus a constant mutual inductance is maintained.

Referring specifically to Fig. 8, there is schematically shown a two-terminal reader coil assembly 70 (primary inductance coil) fixed with respect to a brake caliper mounting bracket, and a sensor coil 72 (secondary inductance coil) mounted on a wheel rim. The respective primary and secondary coils 70, 72 are separated by a constant air gap distance "d". The sensor coil 72 is part of a two-terminal sensor

25

subsystem 74 mounted on the wheel rim inside the tyre cavity. The direction of rotation of the wheel (and hence the sensor coil 72) is shown by arrow 76.

Referring specifically to Fig. 9, there is shown a wheel rim 80 to
5 which is connected a passive sensor 82 (rectifier and capacitor in package). The passive sensor 82 is not grounded to the rim 80 and is connected to a sensor coil 84 via an electrical connection that passes directly through the rim 80 and that includes insulated and sealed terminals 86. This is shown in detail in Fig 19. A reader coil inductor and capacitor
10 assembly 88 mounted to a disc brake caliper bracket 92 is separated from the sensor coil 84 by a constant air gap distance. There is a twisted pair connection 90 for both ground and power/data lines from the reader coil inductor and capacitor assembly 88 to a reader controller.

Referring specifically to Fig. 10, there is shown a wheel rim 94 to
15 which is connected a passive sensor 96 (rectifier and capacitor not in package). The passive sensor 96 has a ground connection 97 to the rim 94 and has an active electrical connection 98 via valve 100 to a sensor coil 102 (rectifier and capacitor inside plastic coil former) mounted on the rim 94. Fixed to the vehicle chassis is a mounting bracket 104 for a disc brake
20 caliper, to which is mounted a reader coil capacitor assembly 106. The reader coil capacitor assembly 106 is separated from the sensor coil 102 by a constant air gap distance. There is a twisted pair connection 108 for both ground and power/data lines from the reader coil capacitor assembly 106 to a reader controller.

25 Fig 11 shows the system's wheel rims and brake caliper mounts. The rim is equipped with the passive sensor and coil elements.

Specifically, Fig. 11 shows a sectioned wheel rim 110 to which is mounted a passive sensor 112 and a plastic former 114 housing a sensor coil. A reader coil assembly 116 is mounted on a disc brake caliper mounting bracket 118 fixed to the vehicle chassis. There is an insulated
5 twisted pair connection 120 from the reader coil assembly 116 to a chassis mounted reader module. It is believed that for most efficient performance, there is an optimal angle θ between the longitudinal axis of the reader coil assembly 116 and the portion of the wall of the rim 110 upon which the plastic former 114 is mounted, an optimal distance D1 between that
10 portion of the rim wall and the sensor coil, and an optimal distance D2 between the sensor coil and the reader coil assembly 116.

Fig 17 shows how each disc brake caliper mounting bracket 122 is equipped with a reader coil assembly 124 (packaged capacitor and inductor), as is the spare tyre position securing clamp. Each reader coil
15 assembly 124 comprises a printed circuit board 126 (PCB) on which is secured a reader coil 128, a capacitor 130 (as a parallel resonant circuit), the PCB 126 being mounted to the disc brake caliper mounting bracket 122 by a bolt assembly. The reader coil assembly 124 is connected to the chassis mounted reader unit or module via a two wire twisted pair
20 connection 132 that terminates in a water proof socket 134 adapted to mate with a plug from the reader module. The general arrangement is shown schematically in Fig 16.

Referring to the block diagram of Fig 12, the reader consists of power transmitter and data receiver sections as well as a microcontroller
25 for signal and data processing. The power transmitter section has a Sinusoidal Oscillator signal (frequency of 572 KHz chosen to be approximately 60 times the sensor element's transmitted data bit

frequency), power amplifier and tuned circuit with energizing coil. The data receiver section has envelope detector, filter and amplifier circuits. As would be well known to persons skilled in the art, the filter circuit rejects unwanted frequencies in the received data signal (i.e. noise) that may arise
5 from wheel eccentricity during rotation and from other sources of noise, the remaining frequencies in the received data signal then being amplified.

The reader's microprocessor program sequentially selects a tyre according to position. The selected tyre's energizing coil (one primary coil per tyre) is then driven by the power amplifier's sinusoidal output signal.
10 The sensor element of the selected tyre derives its power from the energy field generated by the reader coil's (primary) changing (sinusoidal) magnetic flux in close proximity to the sensor coil (secondary).

Referring to Fig 13 and Fig 14, this power is developed by rectifying the sensor coil's induced sinusoidal voltage. When the sensor's power
15 supply circuit (rectifier, capacitor and voltage regulator) develops sufficient DC voltage, the sensor transmits a serial 10 Kbps bit rate biphase encoded datagram containing pressure, temperature, angular velocity and force vector information. This serial datagram is used to drive the gate of a Field Effect Transistor (FET) Q1, effectively shunting the rectifier with the
20 resistor R1 in sympathy with the biphase encoded data. The shunt resistor R1 draws enough current to cause a damping of the oscillating field, also in sympathy with the biphase encoded data. This is seen as a change in amplitude of the field and the primary winding of the reader coil experiences a voltage drop in accordance with the transformer's mutual
25 inductance behaviour. The reader's envelope detector diode peak-detects the amplitude modulated primary voltage at approximately 60dB. This voltage, which represents the decoded tyre data information, is then

filtered and amplified and is now available as a digital serial bit stream to the microprocessor for further analysis. Fig. 15 shows the signal waveforms developed at different locations of the block diagram of Fig. 12. The reader's microprocessor program sequentially selects the next tyre
5 according to position and the cycle is repeated.

The primary and secondary coils are both configured with parallel capacitors having values to achieve parallel resonance at the oscillator's frequency of typically 572 KHz. At resonance, the input impedance is a pure resistance and the stored energy is transferred back and forth
10 between the magnetic field of the inductance and the electric field of the capacitance. At the circuit's resonant frequency, the impedance is small and the forced response is large.

Two methods of connecting the sensor coil to the sensor package are shown in Figures 9 and 10. Fig 9 shows connections via two insulated
15 and sealed electrodes directly through the wheel rim (see also Figs 18 to 21). In this case, the rectifier and tuning capacitor are encapsulated within the sensor package and both Ground and Data/Power connections are electrically insulated (by epoxy resin and rubber seals) from the wheel rim.

Referring specifically to Figs. 18 to 21, there is a stainless steel case
20 140, threaded portion 142 screwably mounted through the wheel rim 144, epoxy resin 146, rubber seal 148, air vent 150 to sensor diaphragm, a two-terminal monolithic integrated circuit pressure and temperature sensor subsystem 152 (with rectifier and tuning capacitor), a ground connection
154 from the sensor subsystem 152, and a power/data electrode 156 from
25 the sensor subsystem 152. There is an insulator 158 between the ground connection 154 and the power/data electrode 156.

In an alternative form, Fig 10 shows the sensor package Ground connection via the internal wheel rim and the active Data/Power connection to the coil made via the valve stem acting as an insulated electrode. This method obviates the need for any additional penetrations through the
5 wheel rim air cavity, however, the rectifier and tuning capacitor are housed in the plastic coil former along with the sensor coil. Importantly, both methods achieve two terminal sensor and coil assembly connections.

It will be appreciated by persons skilled in the art that numerous variations and/or modifications may be made to the invention as
10 represented in the specific embodiments described and depicted herein, without departing from the spirit or scope of the invention as broadly described. The present embodiments are, therefore, to be considered in all respects as illustrative and not restrictive.

CLAIMS

1. A vehicle tyre data monitoring system comprising a wheel mounted sensor means adapted to transmit one or more of pressure, temperature, angular velocity, and force vector data for a tyre as a digital serial datagram through a two-wire, electromagnetically coupled, communication channel to a chassis mounted reader means, the communication channel comprising an electromagnetic coupling means adapted to have constant mutual inductance for all stationary or rotating positions of the tyre and to simultaneously supply power to the sensor means and receive the data for processing and subsequent display to a user of the system,

wherein the sensor means includes a sensor coil that is mounted annularly on a rim of the wheel and is coiled around a first axis, and

wherein the reader means includes a receiver coil that is coiled around a second axis that is noncoincident with the first axis.

2. The vehicle tyre data monitoring system of claim 1 wherein the sensor means comprises a three or more terminal sensor subsystem having at least separate ground, power and data connections which is converted to a two terminal sensor subsystem for transmitting the data across the communication channel to the reader means, with a first terminal being for a ground connection and a second terminal being for a combined power and data connection.

3. The vehicle tyre data monitoring system of claim 2 wherein the two-wire communication channel superimposes the transmission of the data on the power connection as a serial datagram that is received by the receiving means.

4. The vehicle tyre data monitoring system of claim 3 wherein the datagram is decoded by the reader means to provide decoded information that is made available to a microprocessor system for analysis and display of the tyre data to a user of the system.

5. A two-wire communication channel for a vehicle tyre data monitoring system, the channel including electromagnetic coupling means for communicating between a sensor means mounted on a wheel of the vehicle and a reader means mounted on a chassis of the vehicle, and being adapted to transmit one or more of pressure, temperature, angular velocity and force vector data for a tyre as a digital serial datagram from the sensor means to the reader means and to supply power from the reader means to the sensor means, the supply of power being simultaneous with the transmission and reception of the data, wherein the electromagnetic coupling means includes a sensor coil mounted annularly on a rotatable rim for the wheel and a receiver coil mounted on a non-rotating component of a hub for the wheel, the sensor coil and the receiver coil being adapted to maintain a constant mutual inductance therebetween during a complete rotation of the wheel, the sensor and receiver coils providing a non-contacting, two wire communication channel for the data monitoring system,

wherein the sensor coil is coiled around a first axis and the receiver coil is coiled around a second axis that is noncoincident with the first axis.

6. A vehicle wheel to hub electromagnetic coupling interconnection in a tyre data monitoring system for the transmission thereacross of one or more of pressure, temperature, angular velocity and force vector data for a tyre mounted on the wheel, the electromagnetic coupling interconnection comprising a first part mounted on a rotatable rim of the wheel and adapted to receive the data from a sensor means, and a second part mounted on a non-rotating component of a hub for the wheel, the second part being adapted to maintain a constant air gap distance with the first part when the wheel is mounted on the hub so as to maintain constant mutual inductance between the first part and the second part for allowing the data to be transmitted from the first part to the second part, the second part being further adapted to transmit the data to a reader means mounted on a chassis of the vehicle for processing and subsequent display to a user of the system,

wherein the first part includes a sensor coil that is mounted annularly on the rim and that is coiled around a first axis, and

wherein the second part includes a receiver coil that is coiled around a second axis that is noncoincident with the first axis.

7. The vehicle wheel to hub electromagnetic coupling interconnection of claim 6 wherein the constant air gap distance between the first part and the second part is maintained after each mounting of the wheel on the hub.

8. An electromagnetic coupling in a two-wire communication channel for a vehicle tyre data monitoring system, the electromagnetic coupling comprising a first part mounted annularly on a rim of a wheel of the vehicle, and a second part mounted on a non-rotating component of a hub for the wheel, the first part and the second part being adapted to maintain electromagnetic induction therebetween during rotation of the wheel for the transmission of decodable data for the tyre from a sensor means mounted on the wheel to a reader means mounted on the chassis,

wherein the second part comprises a receiver coil mounted on the non-rotating component of the hub for the wheel, and the first part comprises a sensor coil so mounted annularly on the rim of the wheel as to maintain a constant and sufficiently proximate distance to the receiver coil during rotation of the wheel for electromagnetic induction to occur, and

wherein the sensor coil is coiled around a first axis and the receiver coil is coiled around a second axis that is noncoincident with the first axis.

9. The electromagnetic coupling of claim 8 wherein the sensor coil includes a power supply circuit and derives power to operate the sensing and transmission of the data from an electromagnetic flux generated by the receiver coil serving as a power connection, the electromagnetic flux causing the power supply circuit of the sensor coil to develop sufficient DC voltage to enable the sensor means to be energised and to transmit the data to the reader means, the data being adapted

to modulate the electromagnetic flux so as to superimpose the transmission of the data on the power connection as a serial datagram, the so modulated signal being detected and decoded by the reader means to enable the data to be processed and displayed to a user of the system.

1/14

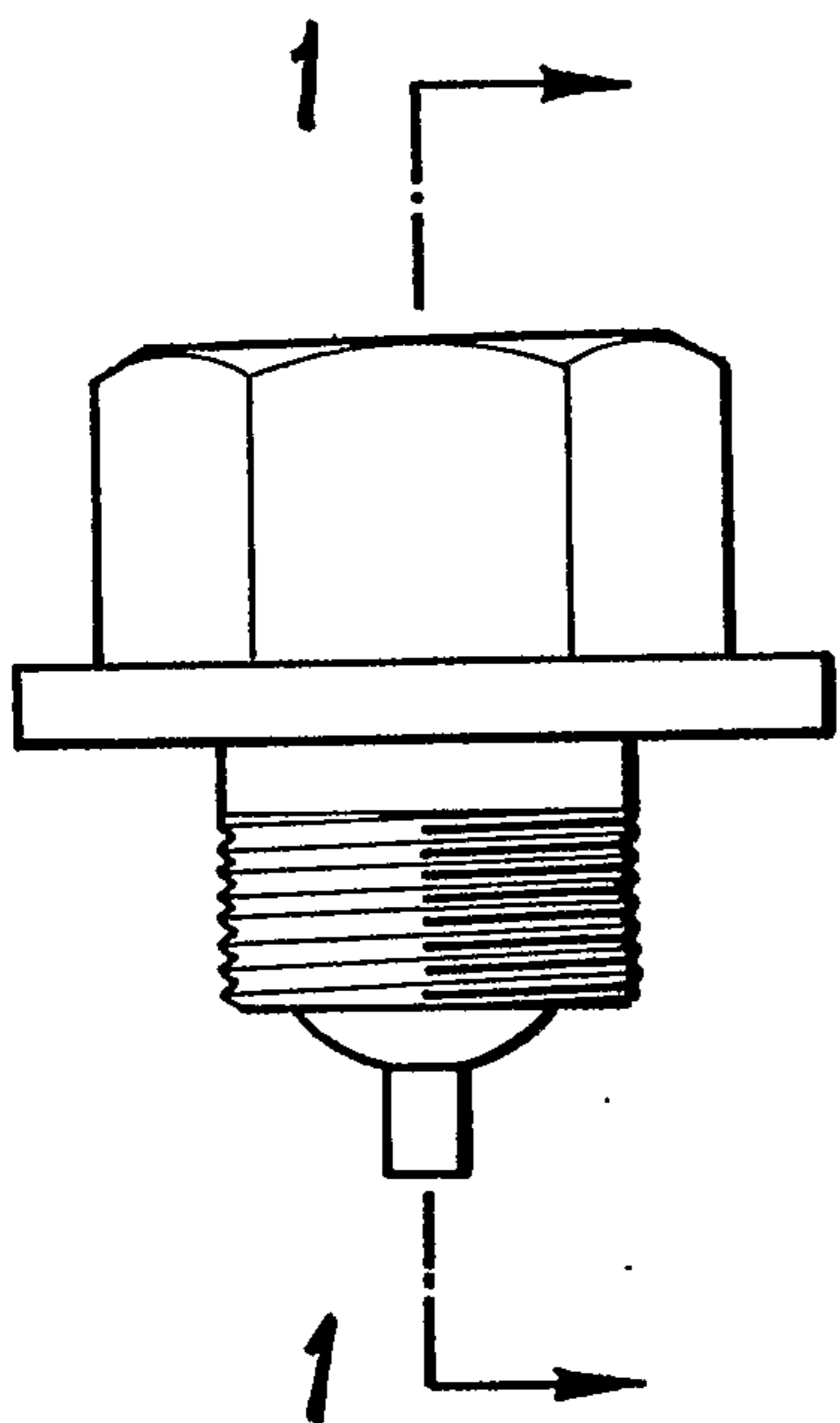

FIG. 1

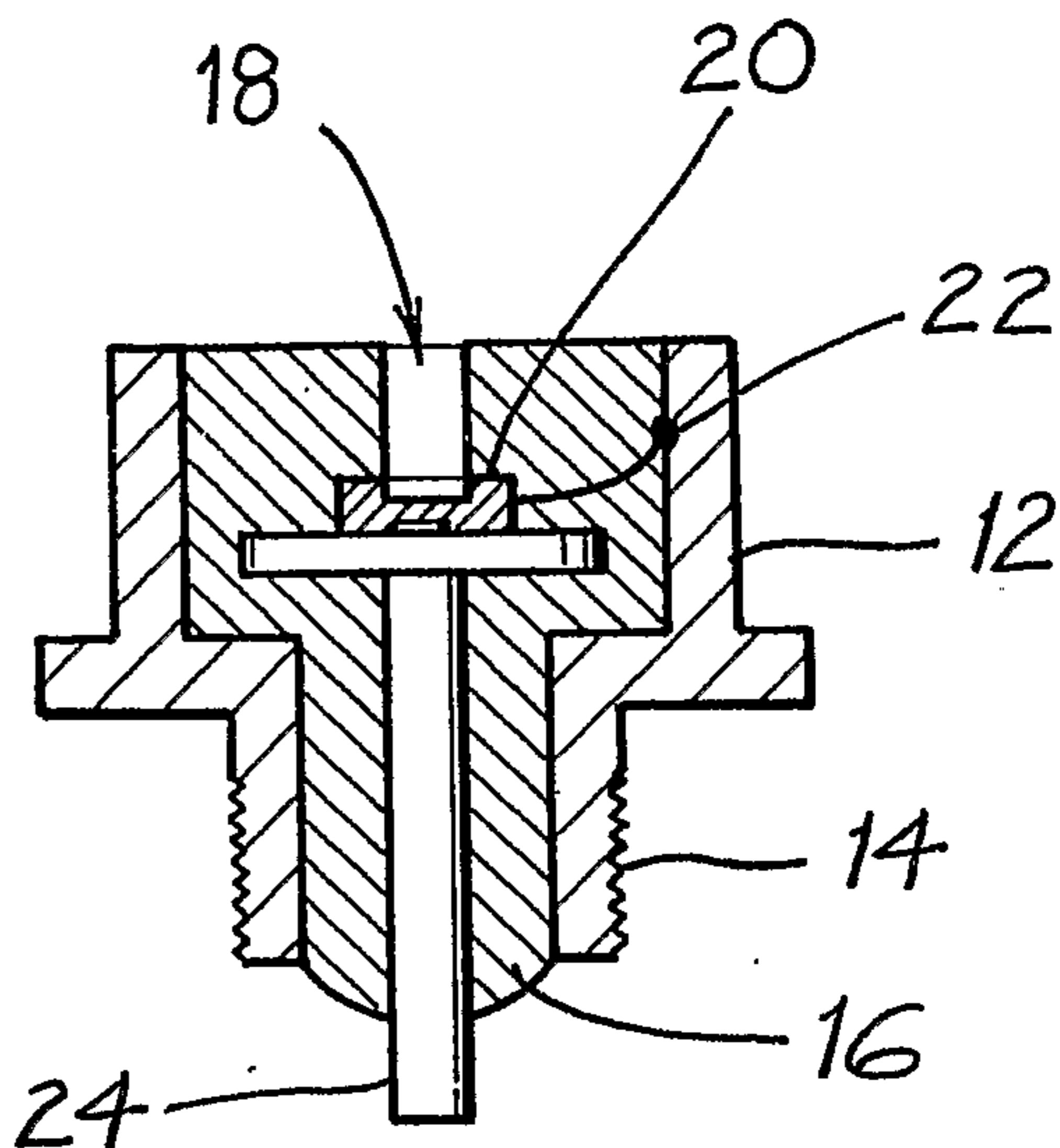

FIG. 2

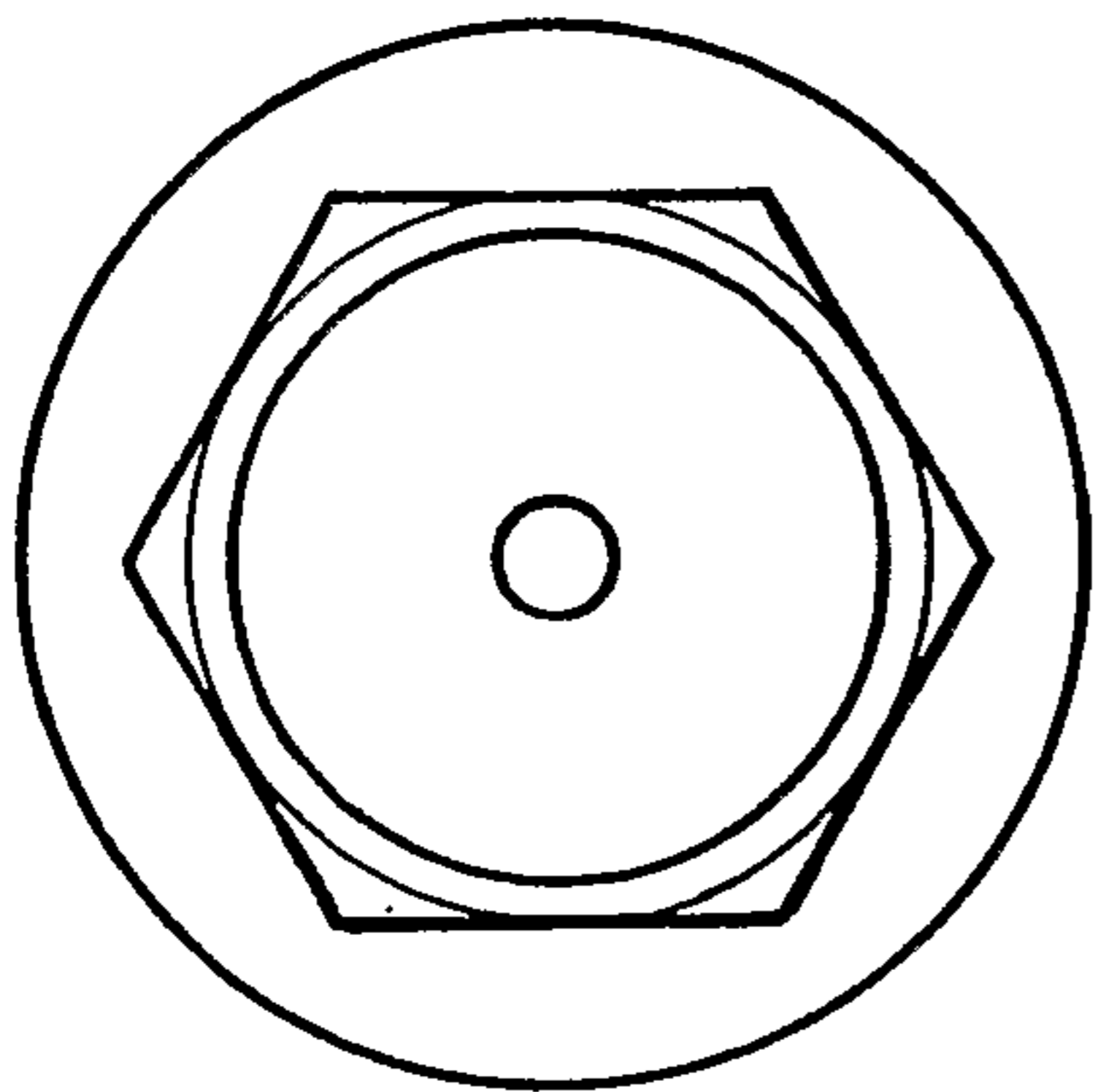

FIG. 3

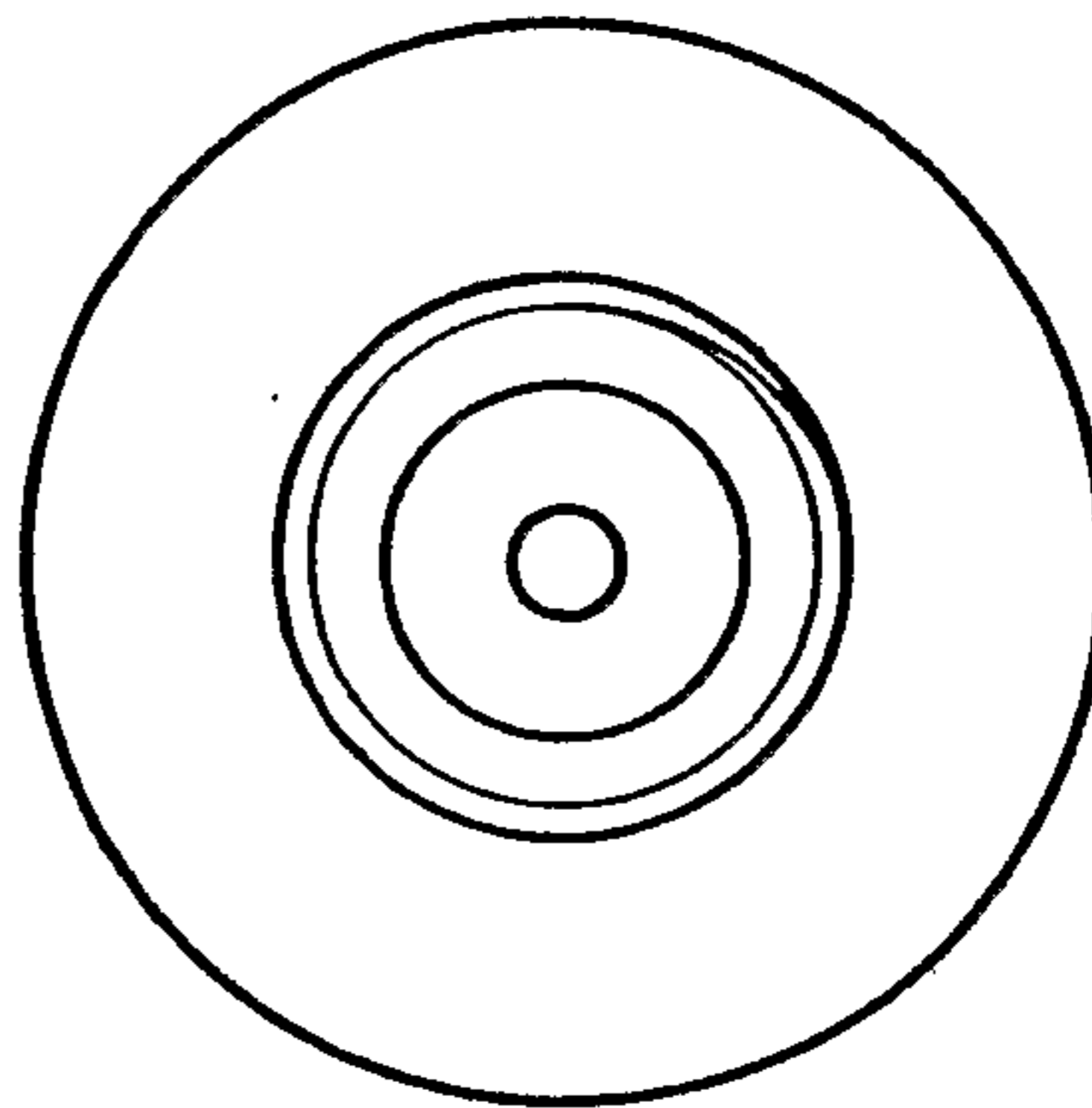

FIG. 4

2/14

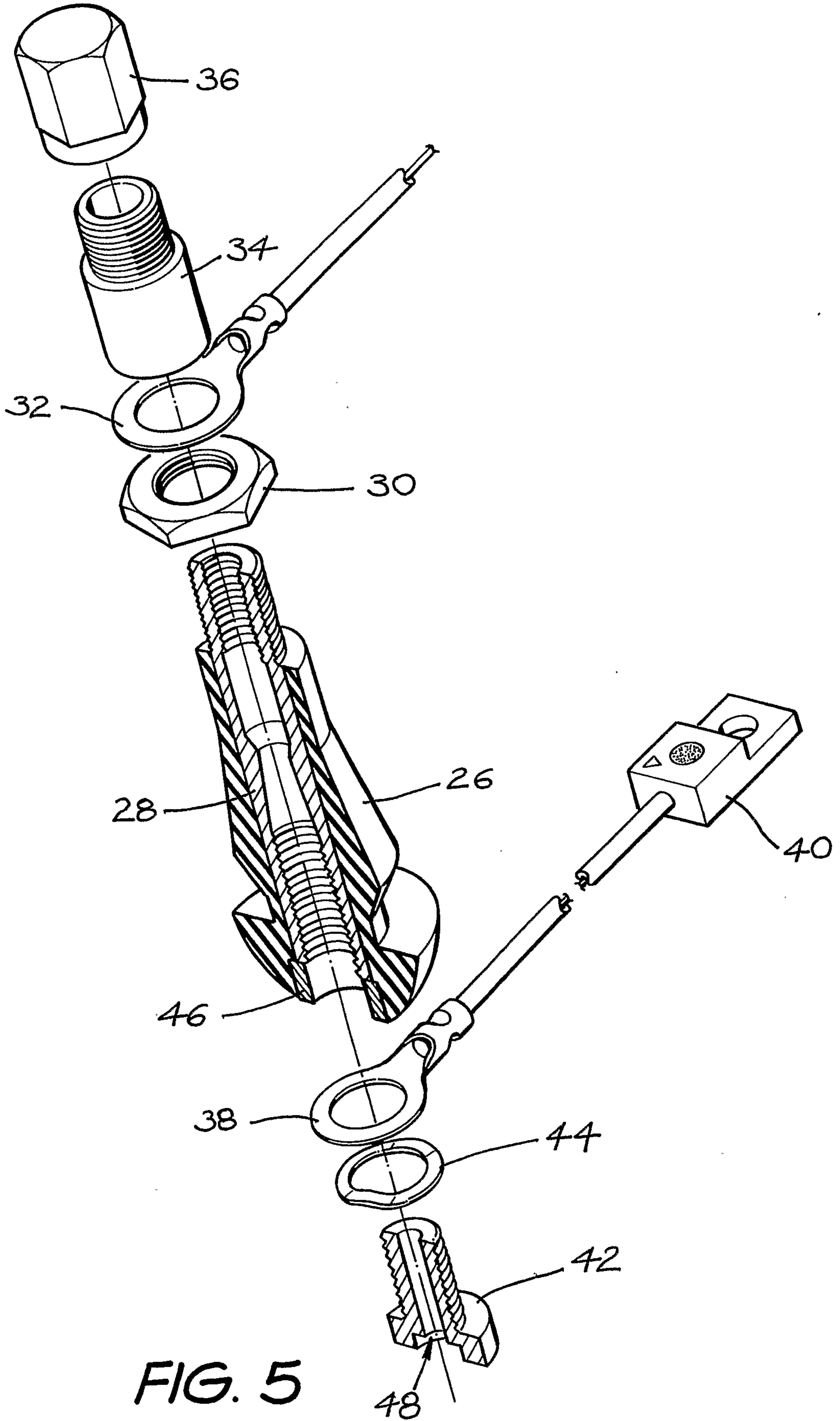
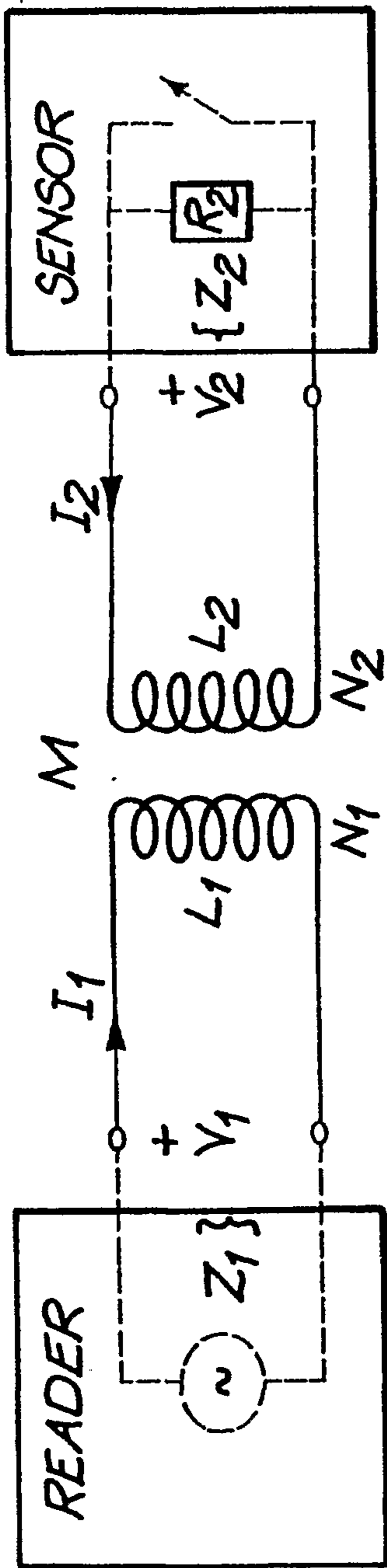

FIG. 5

3/14

INDUCTIVELY COUPLED CIRCUIT



$$V = N d\phi / dt = d\lambda / dt = L dI / dt$$

$$\text{FLUX } \phi = \phi_m \sin 2\pi ft$$

$$V_{RMS} = 4.44 N f \phi_m$$

$$V_2 = (N_2 / N_1) I_2$$

$$I_2 = (V_2 / R_1)$$

THE COMPONENT OF PRIMARY CURRENT DUE TO LOAD IS

$$I_1' = (N_2 / N_1) I_2$$

FIG. 6

4/14

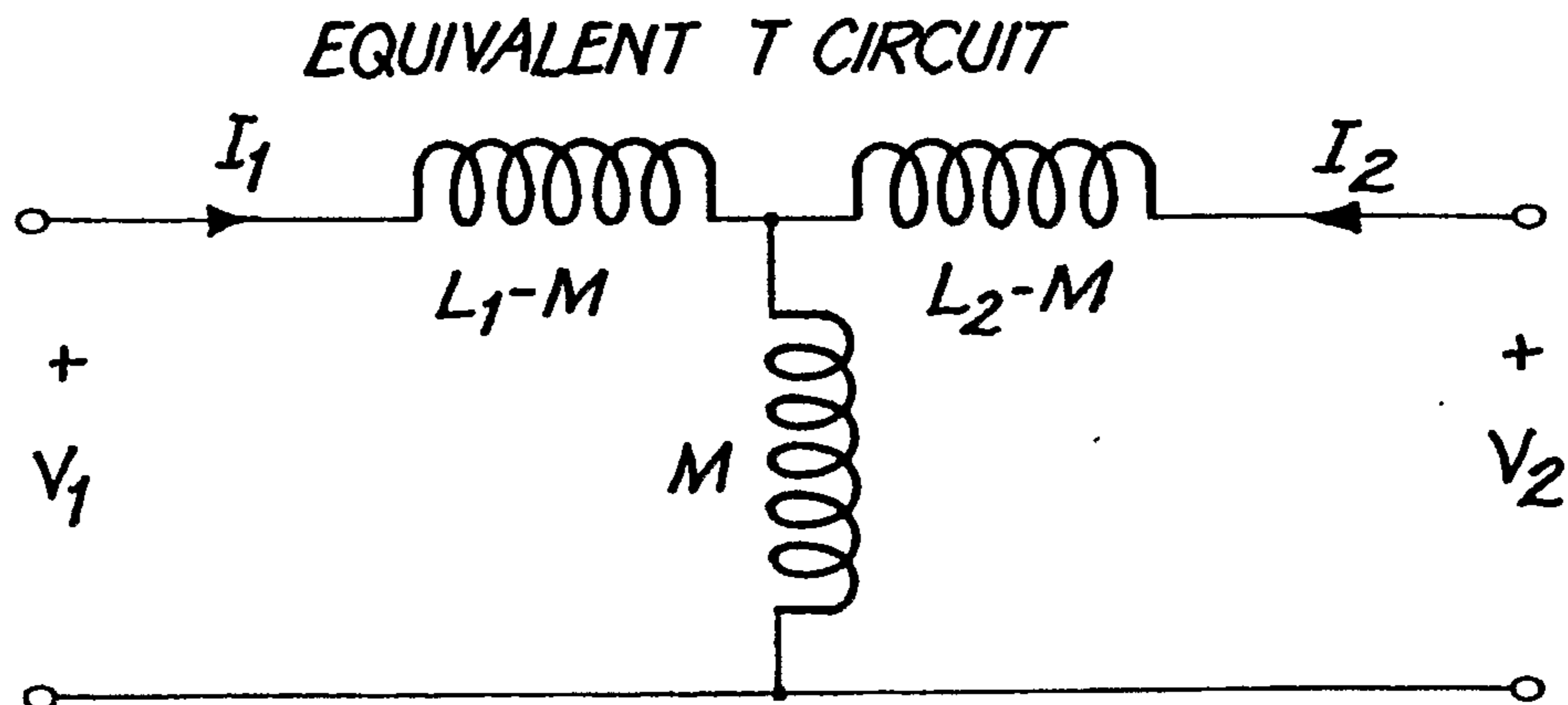

FOR SINUSOIDS, VOLTAGE V_{12} COUPLED INTO
THE INPUT BY A CURRENT I_2 IS $V_{12} = j\omega M_{12} I_2$

WHERE $Z_{12} = j\omega M_{12} =$ MUTUAL IMPEDANCE

IF $Z_{12} = Z_{21}$ OR $M_{12} = M_{21} = M$ USING RECIPROCALITY
FOR A BILATERAL NETWORK,

THEN $V_1 = j\omega L_1 I_1 + j\omega M I_2 = Z_{11} I_1 + Z_{12} I_2$

AND $V_2 = j\omega M I_1 + j\omega L_2 I_2 = Z_{21} I_1 + Z_{22} I_2$

FIG. 7

5/14

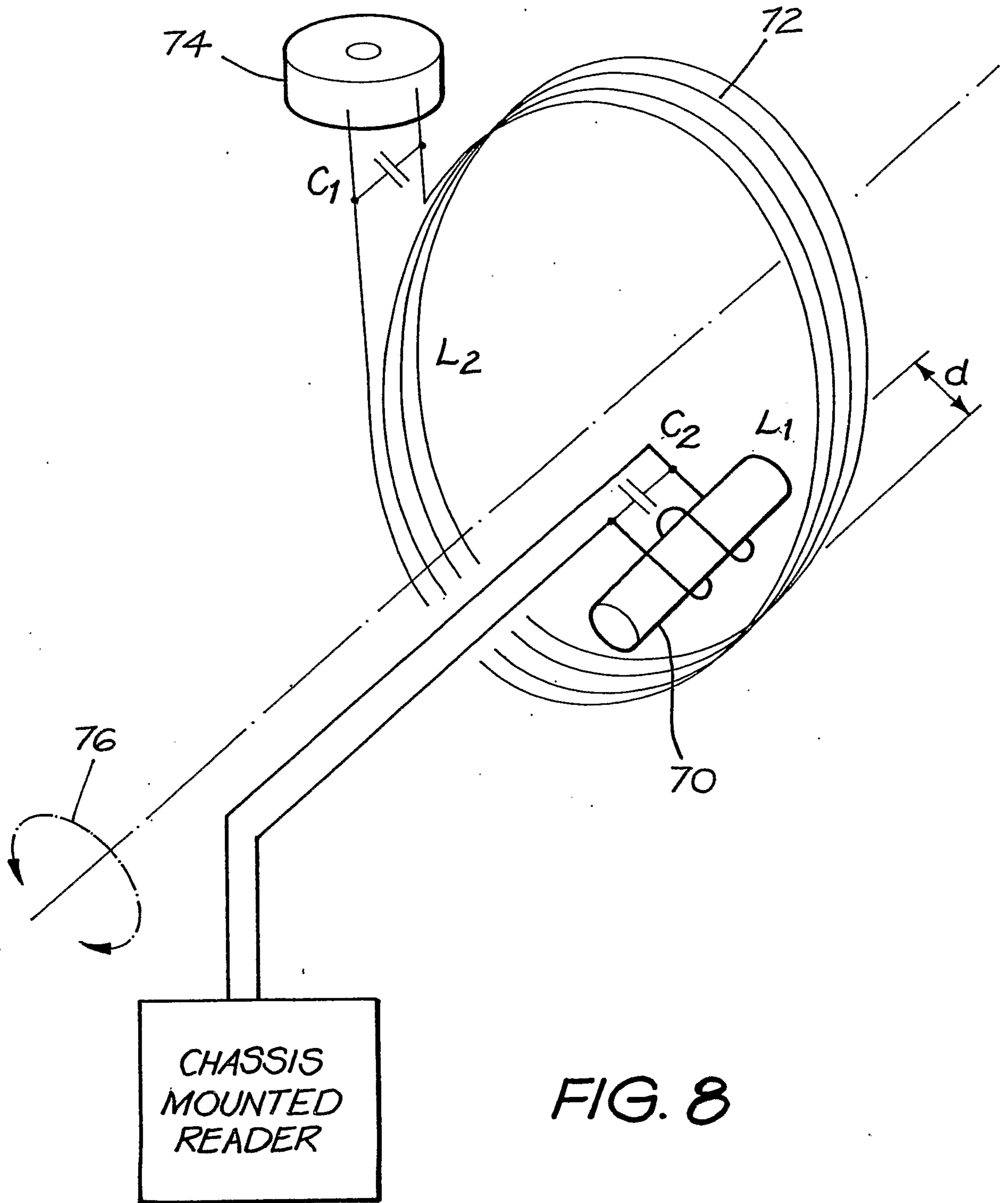

FIG. 8

6/14

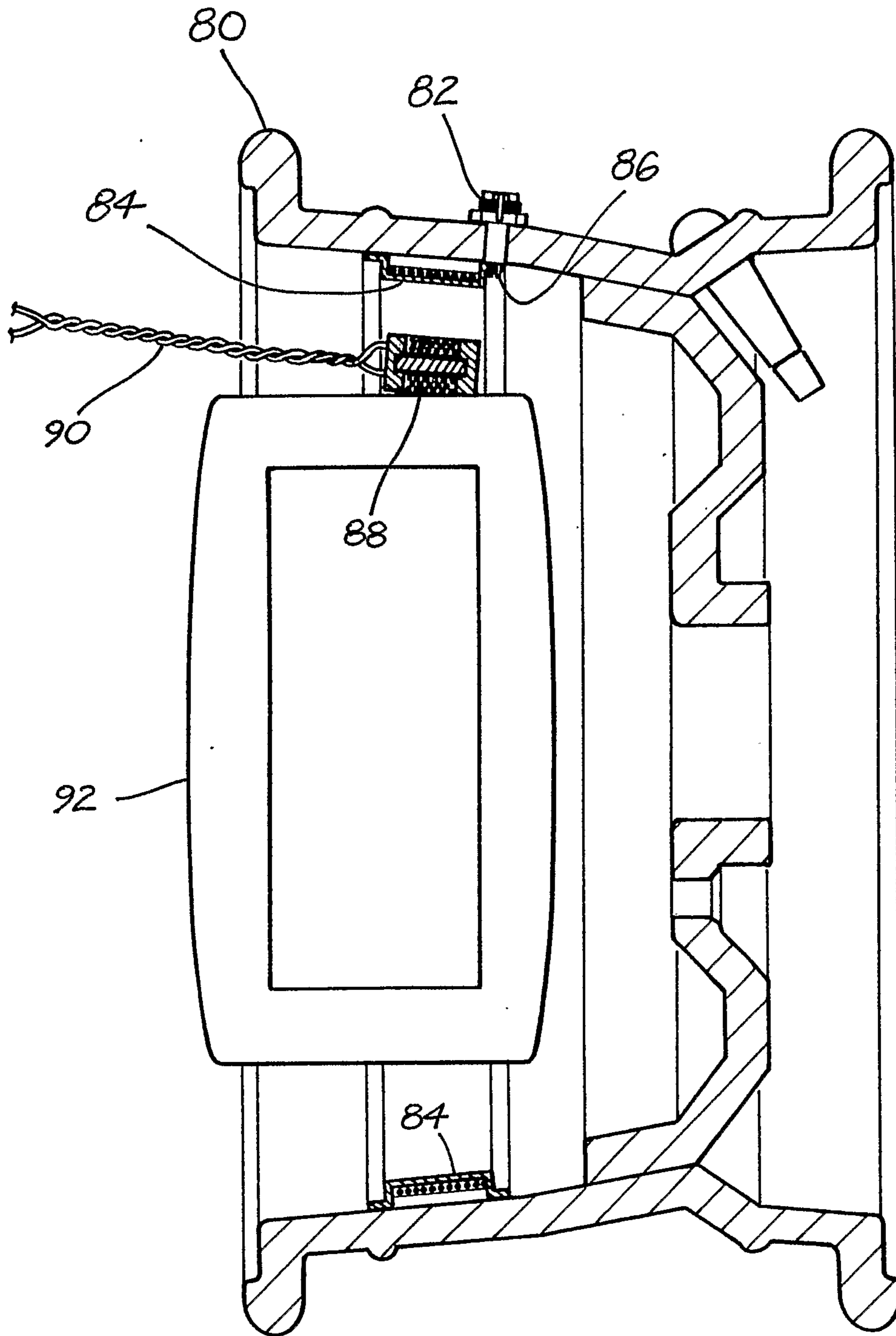

FIG. 9

7/14

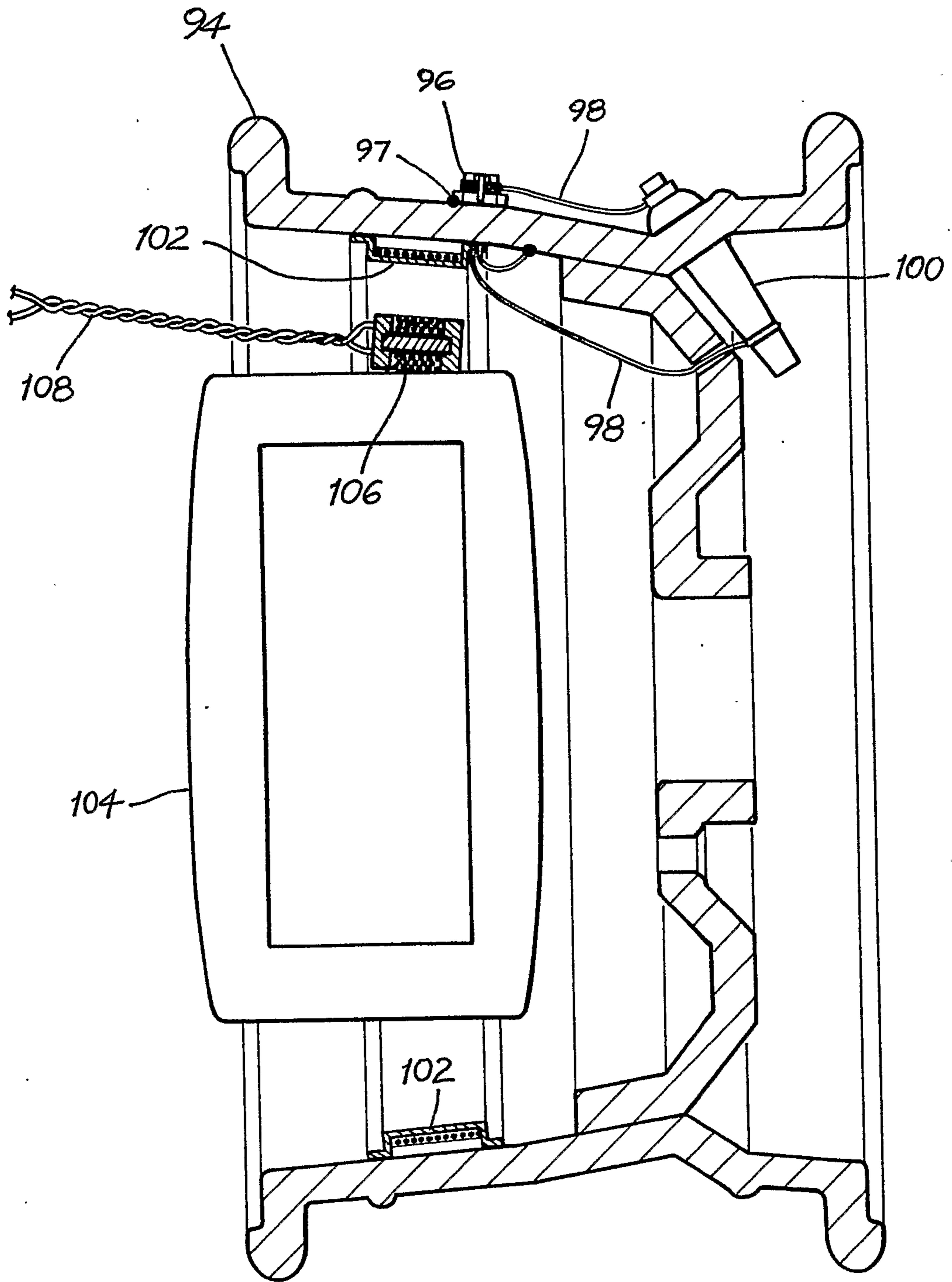

FIG. 10

8/14

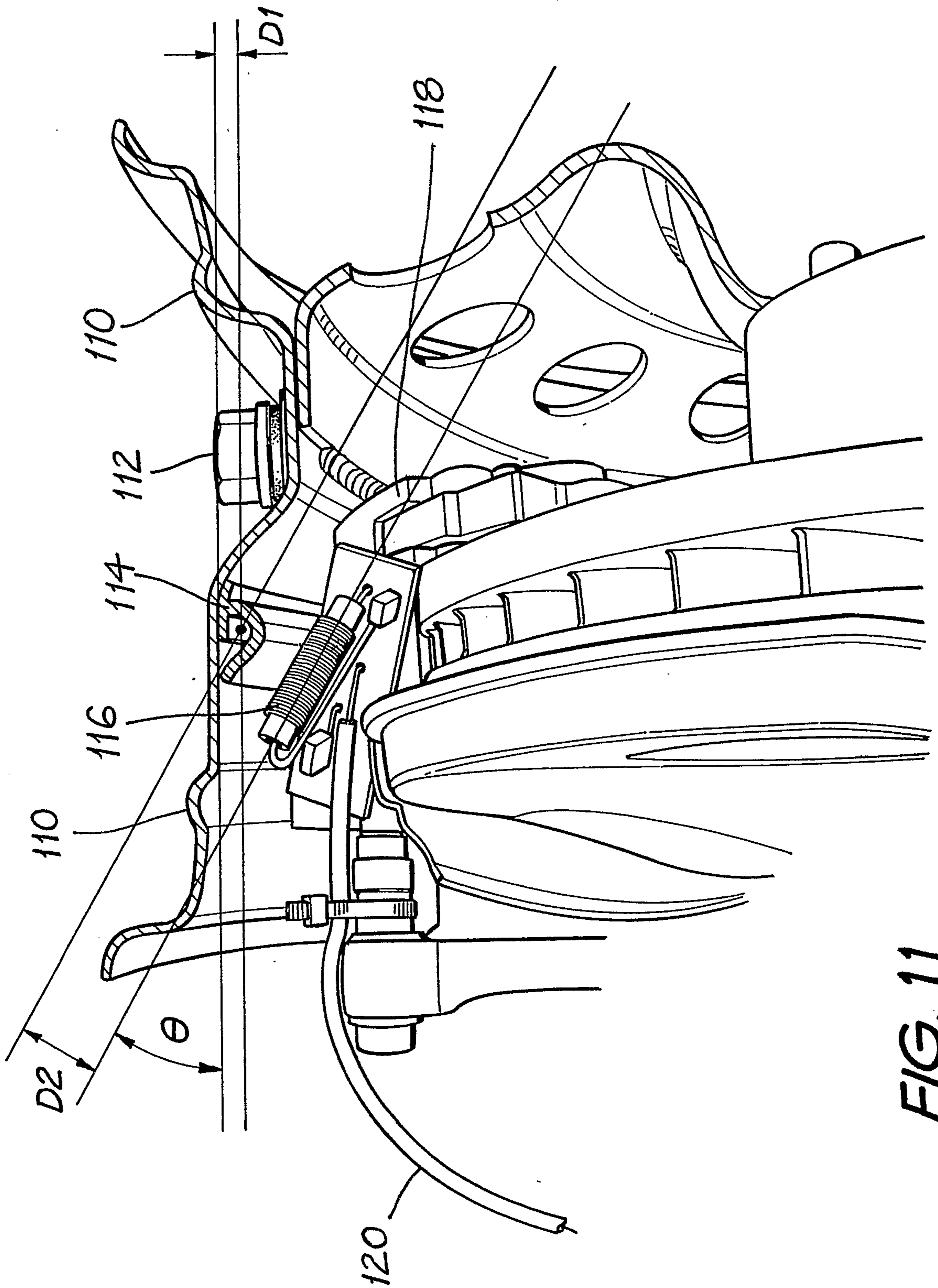

FIG. 11

9/14

SYSTEM BLOCK DIAGRAM

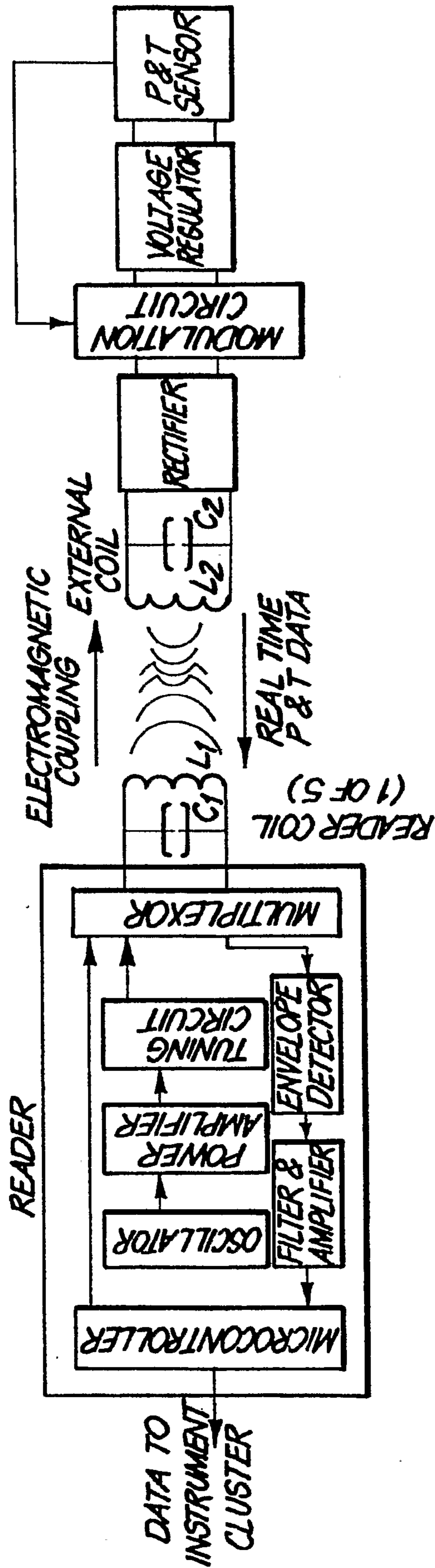

FIG. 12

10/14

EXTERNAL COIL & CAPACITOR -
ALL OTHER COMPONENTS IN SENSOR PACKAGE

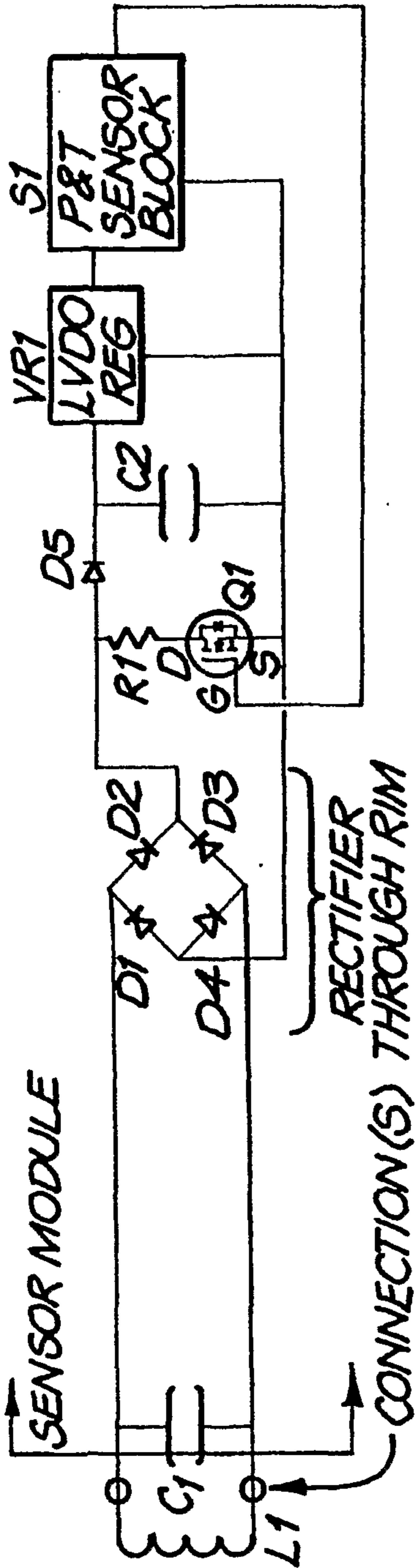

FIG. 13

EXTERNAL COIL, CAPACITOR & BRIDGE RECTIFIER

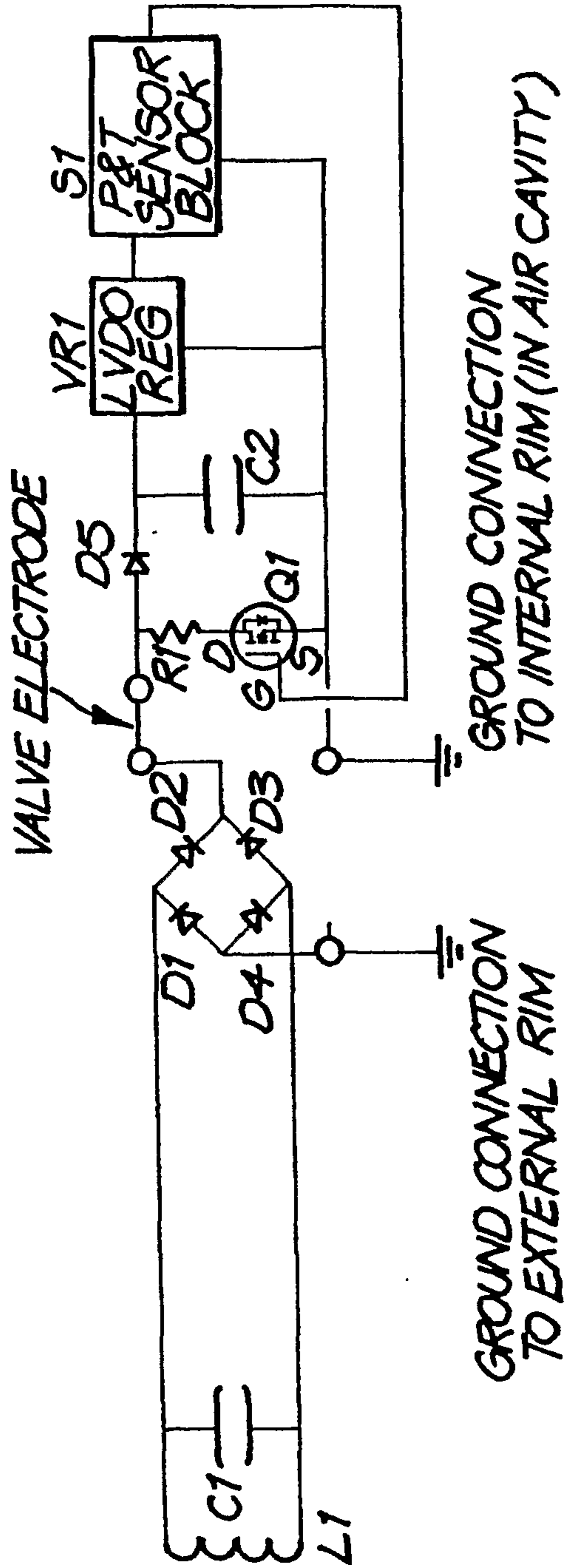

FIG. 14

11/14

ELECTROMAGNETIC COUPLING SIGNAL WAVEFORMS

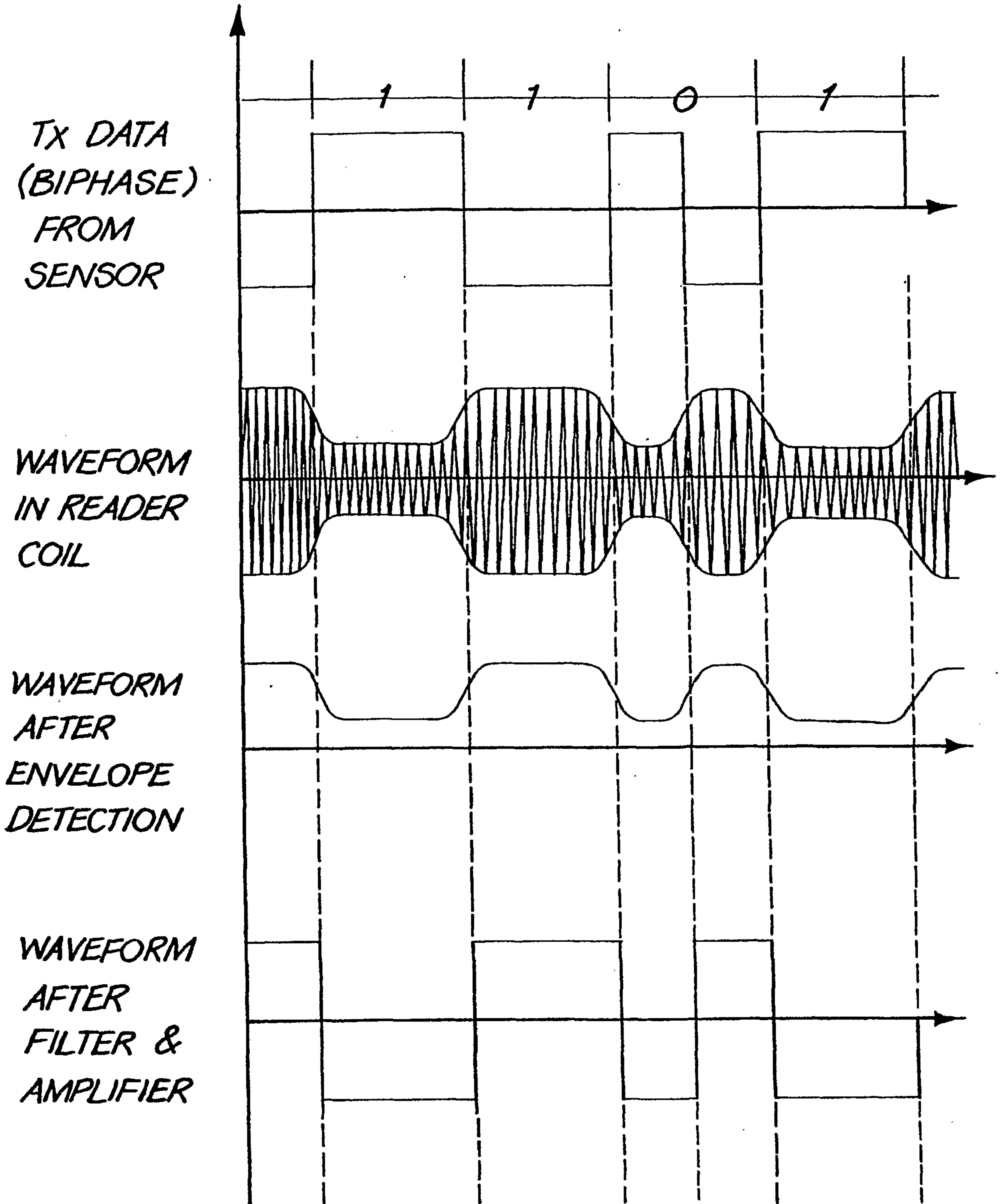

FIG. 15

12/14

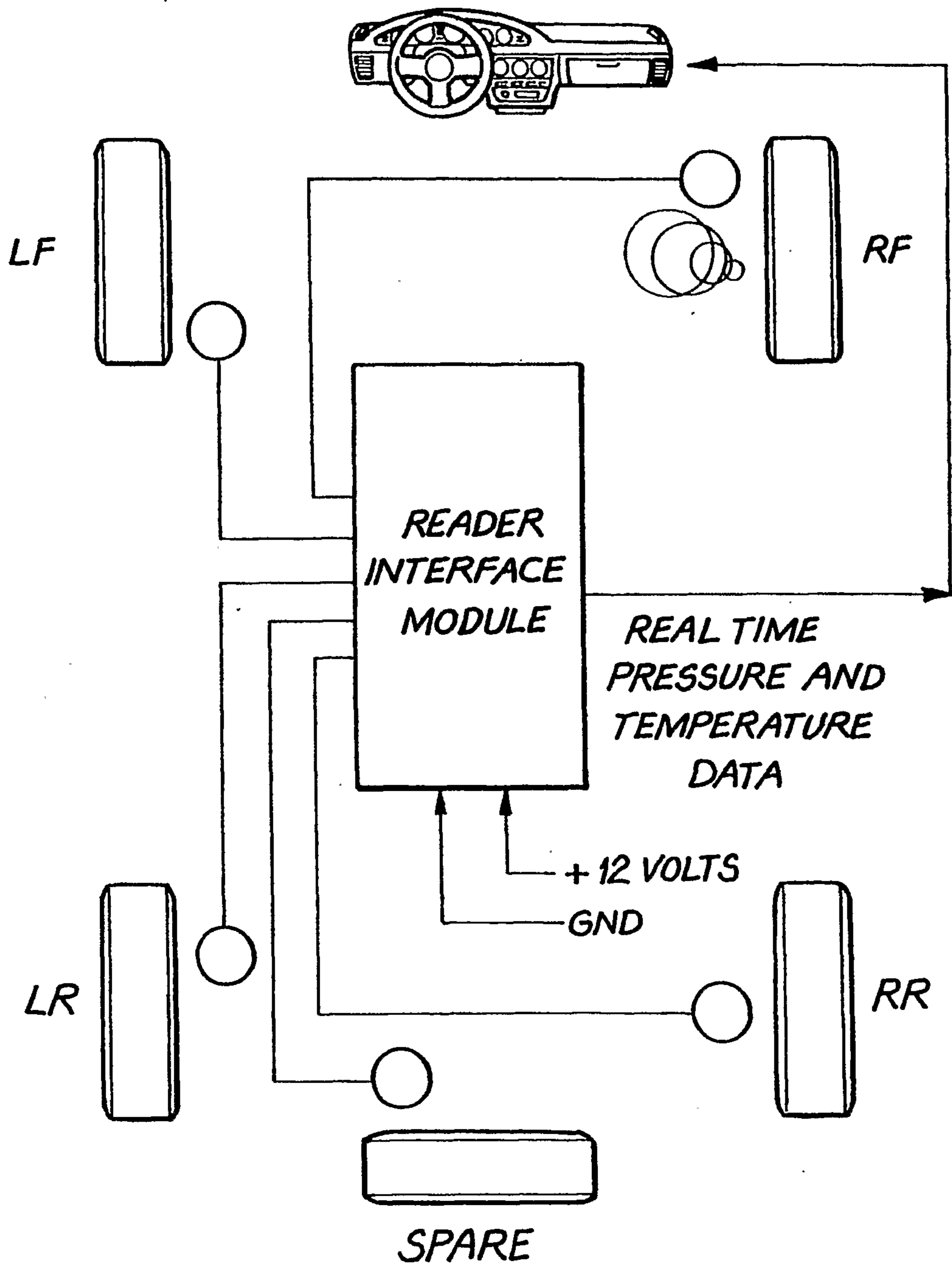

FIG. 16

13/14

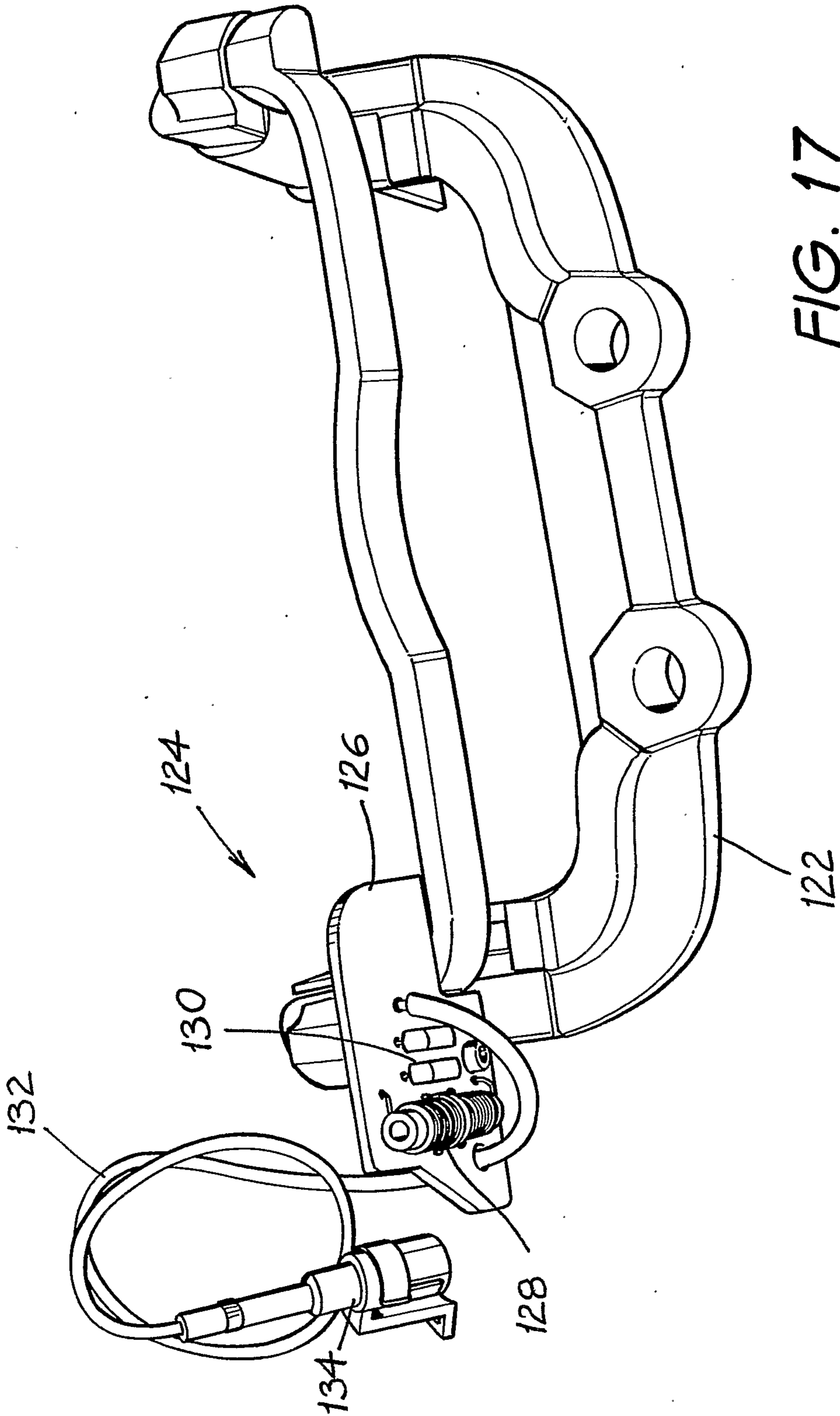

FIG. 17

14/14

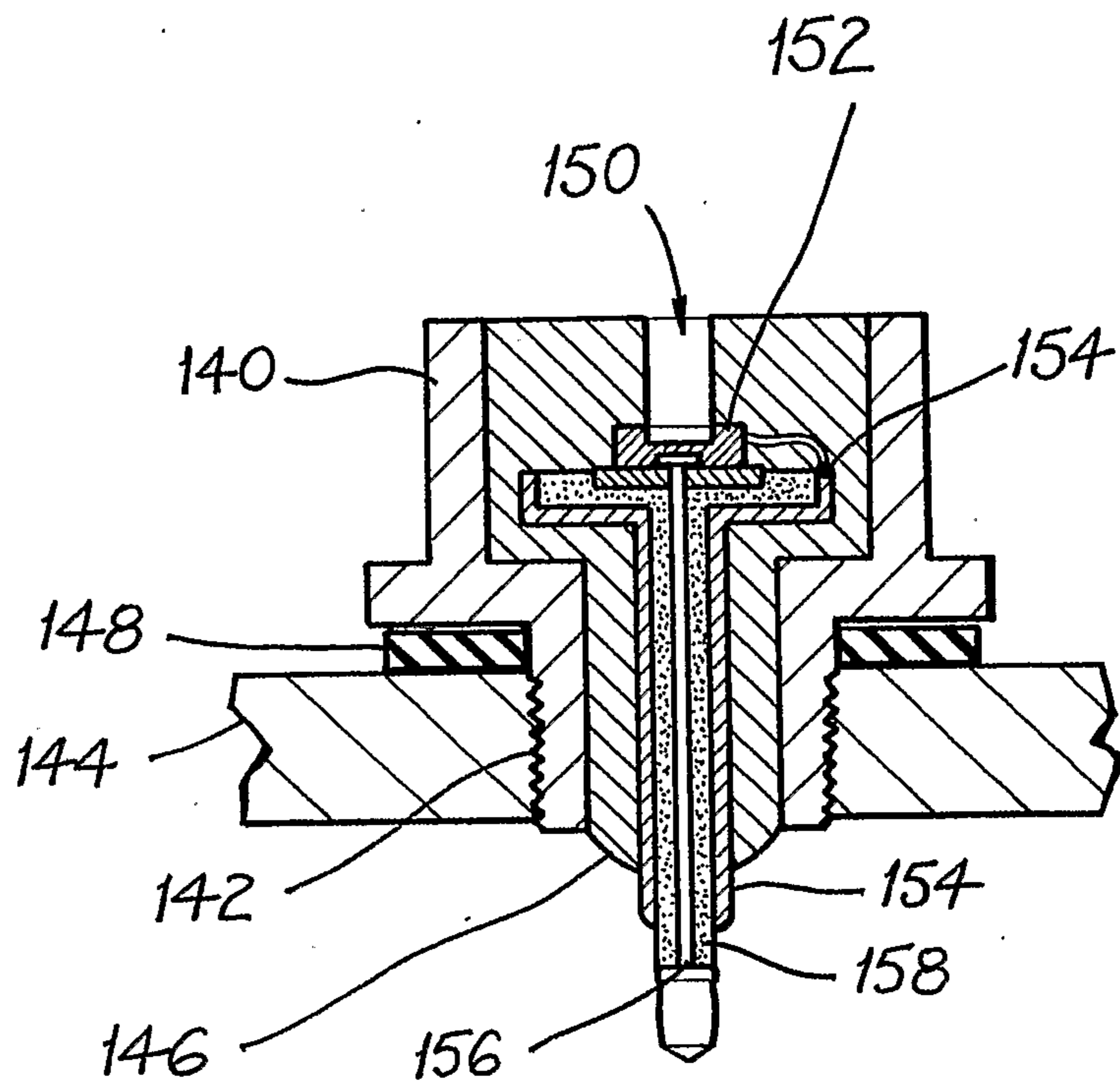
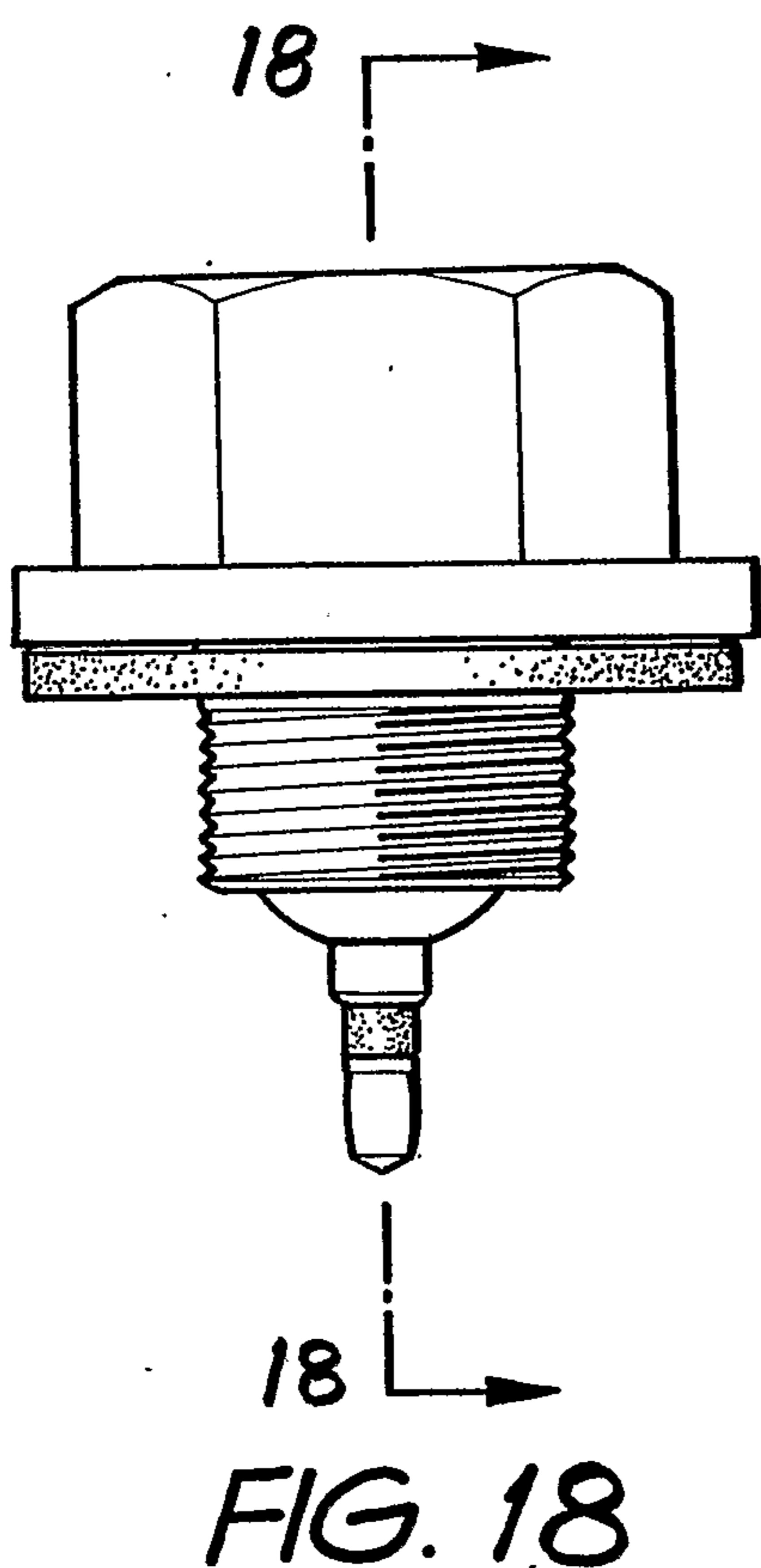

FIG. 19

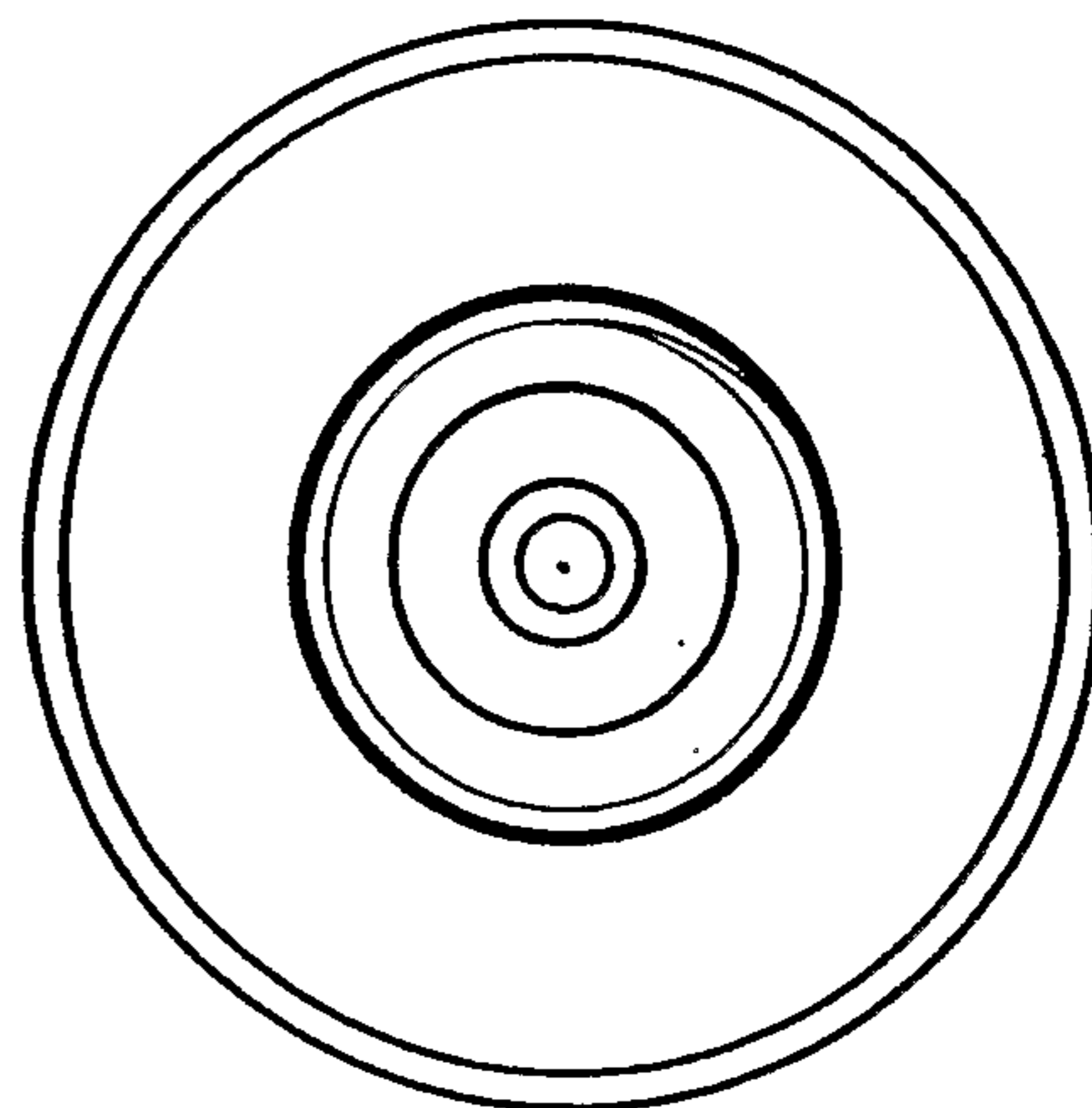
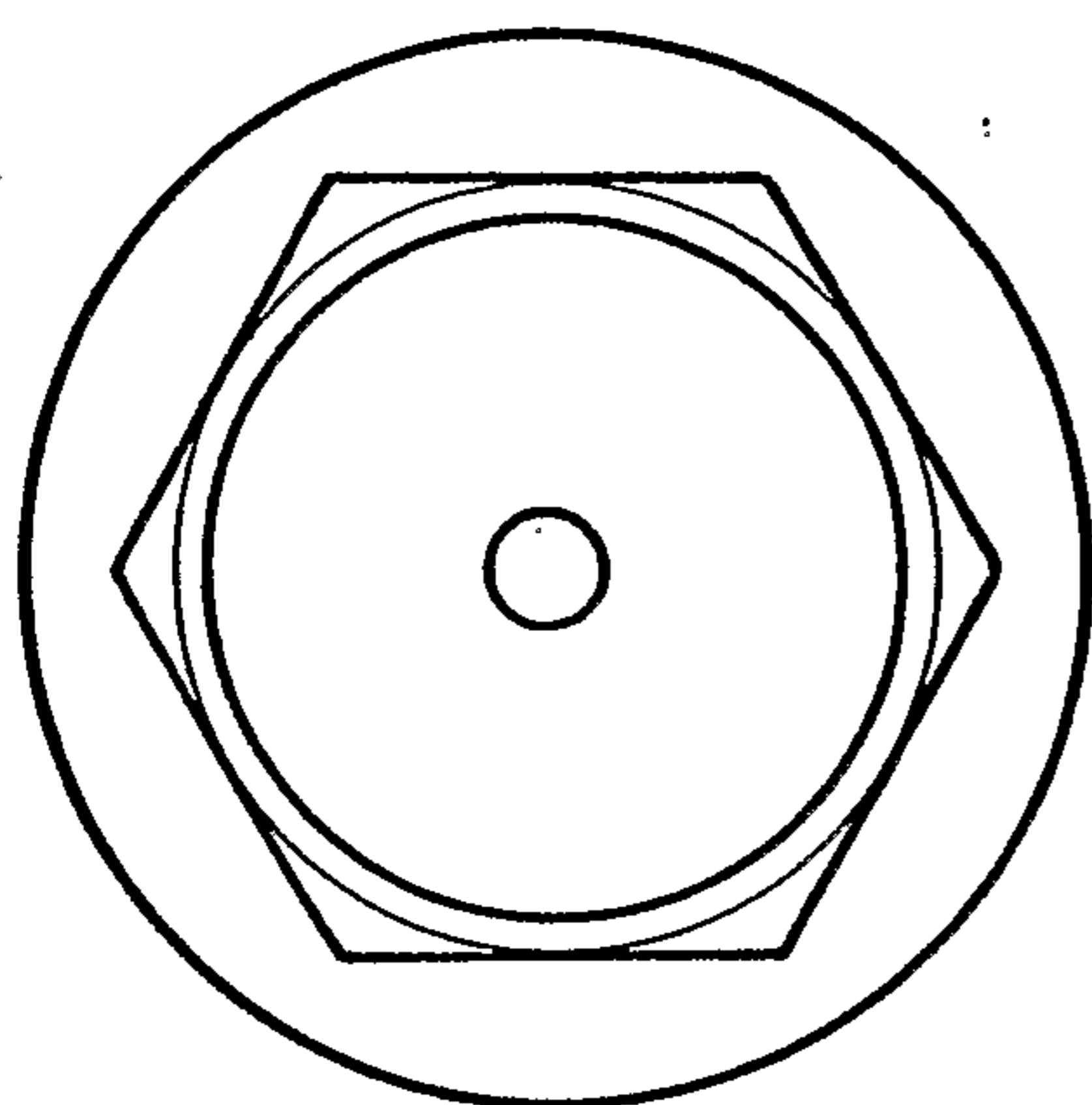

FIG. 20

FIG. 21

SYSTEM BLOCK DIAGRAM

