



(12) **DEMANDE DE BREVET CANADIEN  
CANADIAN PATENT APPLICATION**

(13) **A1**

(86) Date de dépôt PCT/PCT Filing Date: 2019/05/22  
(87) Date publication PCT/PCT Publication Date: 2020/11/26  
(85) Entrée phase nationale/National Entry: 2021/11/19  
(86) N° demande PCT/PCT Application No.: US 2019/033519  
(87) N° publication PCT/PCT Publication No.: 2020/236169

(51) Cl.Int./Int.Cl. *B22C 7/02* (2006.01),  
*B22C 9/10* (2006.01), *B22C 9/24* (2006.01)  
(71) Demandeur/Applicant:  
SIEMENS ENERGY GLOBAL GMBH & CO. KG, DE  
(72) Inventeurs/Inventors:  
MERRILL, GARY B., US;  
RODRIGUEZ, JOSE L., US;  
SCHAENZER, MEGAN, CA  
(74) Agent: SMART & BIGGAR LLP

(54) Titre : NOYAU DE MOULAGE DE PRECISION DOTE D'UN GUIDE D'ALIGNEMENT D'ORGANE DE REFROIDISSEMENT ET PROCEDES ASSOCIES  
(54) Title: INVESTMENT CASTING CORE WITH COOLING FEATURE ALIGNMENT GUIDE AND RELATED METHODS

**FIG. 6**

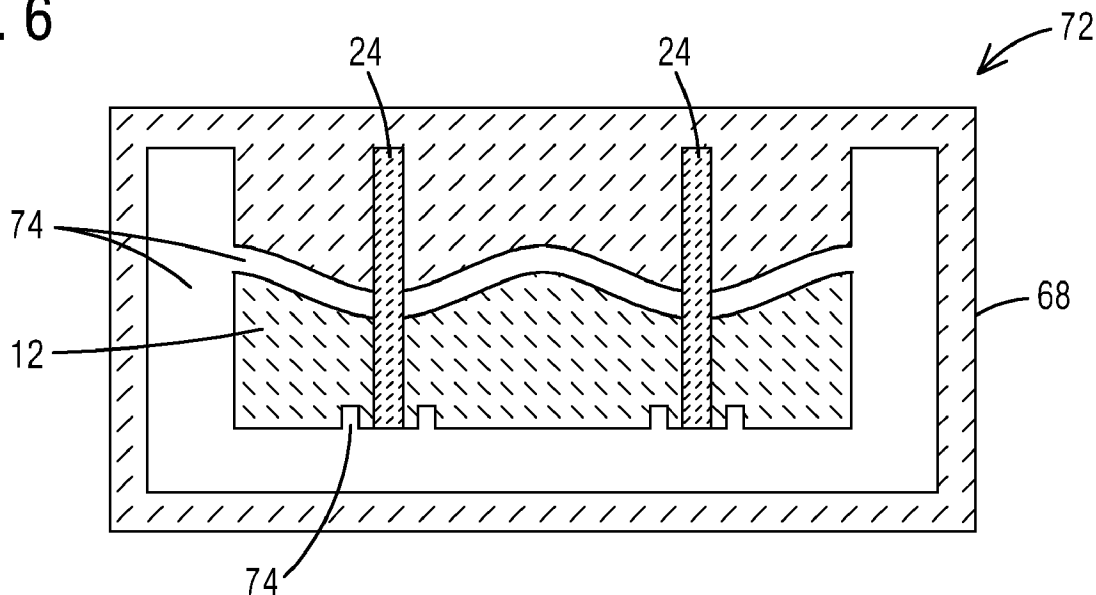

(57) **Abrégé/Abstract:**

An investment casting core (10) incorporates an alignment guide (24) extending through a body (12) of the core. The alignment guide (24) defines a coolant flow path (92) in a later-cast metal component (76) extending from a coolant outlet opening (90) in an impingement structure (88) to an impingement target area (86) of a cooling feature (84) formed on an impingement cooled surface (82) of the component (76). Methods of making the core (10) and using the core (10) in lost wax investment casting processes are also described.

## (12) INTERNATIONAL APPLICATION PUBLISHED UNDER THE PATENT COOPERATION TREATY (PCT)

(19) World Intellectual Property  
Organization  
International Bureau



(10) International Publication Number  
**WO 2020/236169 A1**

(43) International Publication Date  
26 November 2020 (26.11.2020)

- (51) **International Patent Classification:**  
*B22C 7/02* (2006.01)      *B22C 9/24* (2006.01)  
*B22C 9/10* (2006.01)
- (21) **International Application Number:**  
PCT/US2019/033519
- (22) **International Filing Date:**  
22 May 2019 (22.05.2019)
- (25) **Filing Language:** English
- (26) **Publication Language:** English
- (71) **Applicant:** **SIEMENS AKTIENGESELLSCHAFT** [DE/DE]; Werner-von-Siemens-Straße 1, 80333 München (DE).
- (71) **Applicant** (for *BW, GH, GM, KE, LR, LS, MW, MZ, NA, RW, SD, SL, ST, SZ, TZ, UG, ZM, ZW* only): **SIEMENS ENERGY, INC.** [US/US]; 4400 Alafaya Trail, Orlando, Florida 32826-2399 (US).
- (72) **Inventors:** **MERRILL, Gary B.**; 847 Post Lane, Orlando, Florida 32804 (US). **RODRIGUEZ, Jose L.**; 2012 Alaqua Lakes Boulevard, Longwood, Florida 32779 (US). **SCHAENZER, Megan**; 319 Rue St. Philippe, Montreal, Québec H4C2T9 (CA).
- (74) **Agent:** **MUSONE, John P.**; Siemens Corporation- Intellectual Property Dept., 3501 Quadrangle Blvd. Ste. 230, Orlando, Florida 32817 (US).
- (81) **Designated States** (unless otherwise indicated, for every kind of national protection available): AE, AG, AL, AM, AO, AT, AU, AZ, BA, BB, BG, BH, BN, BR, BW, BY, BZ, CA, CH, CL, CN, CO, CR, CU, CZ, DE, DJ, DK, DM, DO, DZ, EC, EE, EG, ES, FI, GB, GD, GE, GH, GM, GT, HN, HR, HU, ID, IL, IN, IR, IS, JO, JP, KE, KG, KH, KN, KP, KR, KW, KZ, LA, LC, LK, LR, LS, LU, LY, MA, MD, ME, MG, MK, MN, MW, MX, MY, MZ, NA, NG, NI, NO, NZ, OM, PA, PE, PG, PH, PL, PT, QA, RO, RS, RU, RW, SA, SC, SD, SE, SG, SK, SL, SM, ST, SV, SY, TH, TJ, TM, TN, TR, TT, TZ, UA, UG, US, UZ, VC, VN, ZA, ZM, ZW.
- (84) **Designated States** (unless otherwise indicated, for every kind of regional protection available): ARIPO (BW, GH, GM, KE, LR, LS, MW, MZ, NA, RW, SD, SL, ST, SZ, TZ, UG, ZM, ZW), Eurasian (AM, AZ, BY, KG, KZ, RU, TJ, TM), European (AL, AT, BE, BG, CH, CY, CZ, DE, DK, EE, ES, FI, FR, GB, GR, HR, HU, IE, IS, IT, LT, LU, LV, MC, MK, MT, NL, NO, PL, PT, RO, RS, SE, SI, SK, SM, TR), OAPI (BF, BJ, CF, CG, CI, CM, GA, GN, GQ, GW, KM, ML, MR, NE, SN, TD, TG).

(54) **Title:** INVESTMENT CASTING CORE WITH COOLING FEATURE ALIGNMENT GUIDE AND RELATED METHODS

FIG. 6

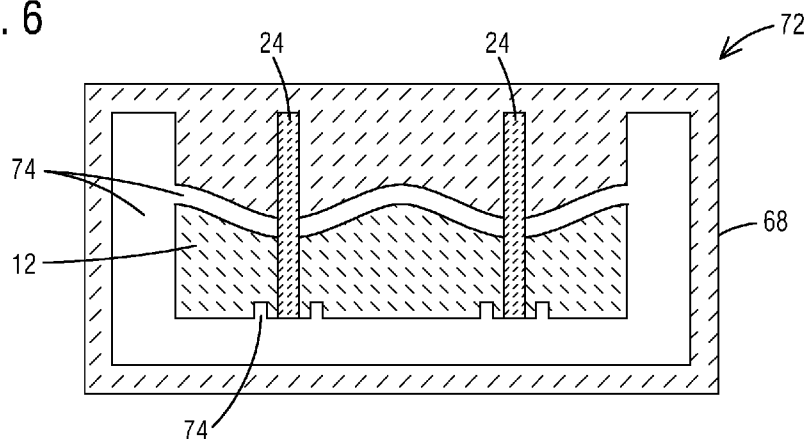

(57) **Abstract:** An investment casting core (10) incorporates an alignment guide (24) extending through a body (12) of the core. The alignment guide (24) defines a coolant flow path (92) in a later-cast metal component (76) extending from a coolant outlet opening (90) in an impingement structure (88) to an impingement target area (86) of a cooling feature (84) formed on an impingement cooled surface (82) of the component (76). Methods of making the core (10) and using the core (10) in lost wax investment casting processes are also described.

[Continued on next page]



WO 2020/236169 A1

**WO 2020/236169 A1** 

---

**Published:**

— *with international search report (Art. 21(3))*

## INVESTMENT CASTING CORE WITH COOLING FEATURE ALIGNMENT GUIDE AND RELATED METHODS

### BACKGROUND

#### 1. Field

5 [0001] The present invention relates generally to the field of investment casting, and more particularly to a method and apparatus for casting advanced cooling features such as are used in gas turbine engine components, and specifically in one embodiment to an investment casting core containing a cooling feature alignment guide.

#### 10 2. Description of the Related Art

[0002] Impingement cooling is often used to cool gas turbine engine components that are exposed to hot combustion gas, for example ring segment shrouds and airfoil leading and trailing edges. The backside of a component surface that is heated by the combustion gas is cooled by one or more jets of cooling fluid directed against the  
15 backside surface from holes formed in an impingement structure which is spaced apart from the backside surface. The impingement structure is typically a perforated plate that is manufactured separately and is later attached mechanically or brazed into position after the component is cast. However, problems can arise due to this complex and time consuming assembly process. United States patent 9,777,581 B2  
20 issued to the assignee of the present invention describes a self-locking impingement device which simplifies the installation of an impingement structure into a cast engine component.

[0003] Cooling fluid is provided in a gas turbine engine at the cost of efficiency. In order to increase engine efficiency, combustion firing temperatures are periodically  
25 increased as material technology and component cooling schemes continue to improve. In order to improve cooling and to minimize the amount of cooling fluid consumed, some modern component designs include the use of engineered cooling features formed on the backside cooled surface to more efficiently transfer heat from the metal surface to the jet of impinging coolant fluid. Further improvements in heat

transfer efficiency and reductions in manufacturing and assembly costs are desired.

## SUMMARY

[0004] The present inventors have recognized that the heat transfer efficiency of engineered impingement cooling features is heavily dependent upon the impinging jet of cooling fluid impacting the cooling feature at the intended impingement target location. The inventors have also recognized that manufacturing and assembly tolerances existing with prior art processes can result in functionally significant misalignment of the impingement structure relative to the associated cooling feature. Accordingly, the inventors disclose herein an investment casting core and related processes which produce the impingement structure in the same casting operation as the cooling feature. This is accomplished by utilizing a casting core incorporating a pre-positioned alignment guide which establishes alignment of a coolant outlet opening in the impingement structure with an associated target impingement area of the cooling feature.

## BRIEF DESCRIPTION OF THE DRAWINGS

[0005] The invention is explained in the following description in view of the drawings that show:

[0006] FIG. 1 is a sectional view of an investment casting core in accordance with an embodiment of the invention.

[0007] FIG. 2 is a sectional view of a mold used to cast the core of FIG. 1.

[0008] FIGs. 3-6 illustrate steps in a lost wax investment casting process utilizing the core of FIG. 1.

[0009] FIG. 7 is a sectional view of a cast metal component formed by the process illustrated in FIGs. 3-6.

25

## DETAILED DESCRIPTION

[0010] In the following detailed description of the preferred embodiment, reference is made to the accompanying drawings that form a part hereof, and in which is shown by way of illustration, and not by way of limitation, a specific embodiment in which the invention may be practiced. It is to be understood that other  
5 embodiments may be utilized and that changes may be made without departing from the spirit and scope of the present invention.

[0011] FIG. 1 is a cross-sectional view of an investment casting core 10 in accordance with an embodiment of the invention. The core 10 is used when casting a metal component such as the gas turbine engine component 76 of FIG. 7 in an  
10 investment casting process described more fully below with reference to FIGs. 3-6. The core 10 includes a body 12 having an impingement plate side 14 and an impingement surface side 16 opposed the impingement plate side 14. The impingement plate side 14 will define a surface of the impingement structure 88 in the later-cast metal component 76, and the impingement surface side 16 will define an  
15 impingement-cooled surface 82 in the later-cast component 76.

[0012] In order to increase the efficiency of the impingement cooling scheme of the later-cast component 76, a geometrically engineered cooling feature 84 may be formed on the impingement-cooled surface 82 of the component 76. The shape 18 of the impingement cooling feature 84 is formed on the impingement surface side 16 of  
20 core 10. The impingement cooling feature shape 18 is illustrated in FIG. 1 as two recesses 20 separated by an impingement target area 22. It will be recognized by one skilled in the art that the shape 18 in the core 10 is the same as, but a negative of, the shape of the corresponding cooling feature 84 to be formed in the later-cast metal component 76; i.e. the recesses 20 in the core 10 will result in two corresponding  
25 protuberances in the later-cast component 76.

[0013] The core 10 also includes an alignment guide 24 extending through the body 12 from the impingement target area 22 to the impingement plate side 14. The alignment guide 24 defines a coolant flow path 92 to be formed in the later-cast metal component 76. A portion 26 of the alignment guide 24 extending away from the body  
30 12 beyond the impingement plate side 14 results in a coolant outlet opening 90 being formed in the impingement structure 88 of the later-cast component 76. The opposed

end of the alignment guide 24 is positioned in the impingement target area 22 and ensures a precise alignment of the coolant jet and the impingement target area 86 of the later-cast component 76. A portion 28 of the alignment guide 24 may extend away from the body 12 beyond the impingement surface side 16 in order to facilitate manufacture of the core 10, as will be discussed further with respect to FIG. 2 below, although this portion 28 may be removed prior to using the core 10 in a metal casting process.

**[0014]** The impingement plate side 14 of the core 10 is illustrated in FIG. 1 as including a plurality of peaks 29 and valleys 30 relative to the impingement surface side 16. Such a sinusoidal shape in three dimensions may define an auxetic surface shape 32 which exhibits a negative Poisson's ratio, i.e. a structure that will expand both along and transverse to a direction of an applied load. The present inventors have recognized that an impingement structure exhibiting a negative Poisson's ratio may be advantageous in order to control loads for embodiments such as a gas turbine engine component. Moreover, by locating the alignment guide 24 at the apex of a valley 30, the length of the resulting cooling fluid flow path 92 in the later-cast metal component 76 is minimized, thereby maximizing cooling effectiveness. Other embodiments of the invention may utilize a core having a planar, non-sinusoidal, and/or non-auxetic impingement plate side to form an impingement structure having the traditional positive Poisson's ratio.

**[0015]** FIG. 2 illustrates a core casting mold 40 and a method which may be used to form the core 10 of FIG. 1. The mold may be a flexible mold formed of two or more parts 42, 44 for easy separation and removal of the core 10 after being cast in the mold 40. A first mold part 42 has an interior surface 46 defining the impingement plate side 14 of the core 10, and the second mold part 44 has an interior surface 48 defining the impingement surface side 16 of the core 10, including the impingement cooling feature shape 18 and impingement target area 22. The second mold part 44 includes a first recess 50 corresponding to the location of the impingement target area 22 for receiving a first end 52 of the alignment guide 24. The second mold part 42 includes a second recess 54 for receiving a second end 56 of the alignment guide 24. In the embodiment shown, the second recess 54 is a through hole ending at the apex 58 corresponding to a valley 30 of the core 10. When the two mold parts 42, 44 are

joined together, the alignment guide 24 assures that the second recess 54 is perfectly aligned with the first recess 50, which ensures alignment of the coolant jet 92 and impingement target area 86 in the later-cast metal component 76, as will be discussed more fully below.

5 [0016] Core material is introduced into the mold 40, such as in the form of a ceramic slurry, and is allowed to solidify around the alignment guide 24 to form the core 10. The material of the alignment guide 24 is selected to be compatible with the core material, and may be a high density silica material, for example. The alignment guide 24 may have a circular cross section, such as a 2 mm diameter silica rod, or  
10 have any other cross-sectional shape desired for the resulting cooling fluid channel 90 in the later-cast metal component 76. After drying/solidifying, the core 10 is removed from the mold 40, sintered and trimmed as necessary, and is available for use in a subsequent metal casting process, as described further below with reference to FIGS. 3-6.

15 [0017] FIG. 3 illustrates the core 10 after its removal from the mold 40 of FIG. 2. A layer of wax such as wax sheet 60 is applied to the impingement plate side 14 of the core 10. The wax sheet 60 will function in a subsequent lost wax process to define a volume of the impingement structure 88 of the later-cast metal component 76. The wax sheet 60 may be separately formed in a flexible mold (not shown) including  
20 openings for receiving the portion 26 of the alignment guides 24 extending beyond the impingement plate side 14. The exposed alignment guide portions 26 can be used as an effective anchor for a subsequent shell dip operation described with reference to FIG. 5 below. The portion 28 of the alignment guide 24 extending beyond the impingement surface side 16 in FIG. 1 may be removed (as illustrated in FIG. 3) if  
25 desired. To ensure a good seal between the wax sheet 60 and the protruding alignment guides 24, a thin spray coating of wax 62 may optionally be applied over the wax sheet 60 at least in regions surrounding the alignment guides 24.

[0018] FIG. 4 illustrates the core 10 and layer of wax 60 of FIG. 3 being attached to a wax base 64 to form a wax pattern 66.

30 [0019] The wax pattern 66 is processed in a standard shelling operation to be

encased by a ceramic shell 68, as illustrated in FIG. 5, and the resulting assembly 70 is dried, dewaxed and sintered to form a casting mold 72, as illustrated in FIG. 6. The casting mold 72 includes the core body 12 and alignment guides 24 within the ceramic shell 68 and it defines voids 74 therein having the shape of a desired metal component 76.

[0020] The casting mold 72 is then utilized in a metal casting process wherein molten metal is introduced into the voids 74 and allowed to cool and to solidify to form a cast metal component 76. FIG. 7 illustrates the cast metal component 76 after removal of the ceramic casting mold 72. The cast metal component 76 is illustrated as embodiment is a gas turbine engine ring segment having a wall 78 with a surface 80 that will be exposed to a hot combustion gas during operation of the component 76 in a gas turbine engine. The wall 78 includes a backside impingement surface 82 having engineered cooling features 84 with respective impingement target areas 86. The component 76 also includes an impingement structure 88 spaced apart from the impingement surface 82 and including a plurality of coolant outlet openings 90 through which coolant will flow during operation of the component 76 in a gas turbine engine. The presence of the alignment guides 24 in the casting mold 72 defines an impingement jet flow path 92 precisely aligned between each of the outlet openings 90 and a respective impingement target area 86.

[0021] Demolding of component 76 from the casting mold 72 can be accomplished by standard mechanical and/or leaching processes. In one embodiment, the ceramic shell 68 is removed by mechanical means, the alignment rods 24 are at least partially drilled out to clear the openings 90 in the impingement structure 88, and then chemical leachate is introduced through the openings 90 for removing the core body 12. Inspection of interior portions of the demolded component 76, including inspection of the cooling features 84 and impingement target areas 86 for proper geometry and complete cleaning, may be accomplished via access through the openings 90 with a borescope or fiber optic inspection tool.

[0022] The present invention allows an impingement structure 88 to be cast together with the impingement cooling features 84 on a impingement cooled wall 78 of a component 76, thereby ensuring perfect alignment there between, eliminating the

need for separate fabrication and attachment of the impingement structure 88. In this manner, cooling efficiency is optimized and the duration and cost of production can be reduced when compared to prior art methods.

**[0023]** While specific embodiments have been described in detail, those with ordinary skill in the art will appreciate that various modifications and alternatives to those details could be developed in light of the overall teachings of the disclosure. Accordingly, the particular arrangements disclosed are meant to be illustrative only and not limiting as to the scope of the invention, which is to be given the full breadth of the appended claims, and any and all equivalents thereof.

## CLAIMS

What is claimed is:

- 5           1. A core (10) for use in an investment casting process, the core comprising:  
a body (12) comprising an impingement plate side (14) and an impingement  
surface side (16) opposed the impingement plate side;  
a shape (18) of an impingement cooling feature formed on the impingement  
surface side, the impingement cooling feature shape defining an impingement target  
10 area (22); and  
an alignment guide (24) extending through the body from the impingement target  
area to the impingement plate side, and a portion (26) of the alignment guide  
extending away from the body beyond the impingement plate side.
- 15           2. The core of claim 1, further comprising a portion (28) of the alignment guide  
extending away from the body beyond the impingement target area.
3. The core of claim 1, wherein the impingement plate side of the body defines  
peaks (29) and valleys (30) relative to the impingement surface side.  
20
4. The core of claim 3, wherein a valley of the impingement plate side (14) is  
aligned with the impingement target area (22) by the alignment guide (24).
5. The core of claim 4, wherein the impingement plate side of the body defines  
25 an auxetic surface shape (32).
6. The core of claim 1, wherein the impingement plate side of the body  
comprises an auxetic surface shape (32), and a valley (30) of the auxetic surface shape  
relative to the impingement surface side is aligned with the impingement target area  
30 by the alignment guide.

7. A method of forming the core of claim 1, the method comprising:  
forming a first mold part (42) defining the impingement surface side of the core,  
including the impingement cooling feature comprising the impingement target area;  
forming a second mold part (44) defining the impingement plate side of the core;  
5 forming a first recess (50) in the impingement target area of the first mold part for  
receiving a first end (52) of the alignment guide;  
forming a second recess (54) in the second mold part for receiving a second end  
(56) of the alignment guide;  
joining the first mold part, the second mold part and the alignment guide together  
10 with the first end of the alignment guide inserted into the first recess and the second  
end of the alignment guide inserted into the second recess to form a core casting mold  
(40);  
introducing body material into the core casting mold and allowing the body  
material to solidify around the alignment guide to form the core (10); and  
15 removing the core from the core casting mold.

8. The method of claim 7, further comprising forming the first mold part (42) to  
define the impingement plate side of the core to comprise peaks (29) and valleys (30)  
relative to the impingement surface side (48).

9. The method of claim 8, further comprising using the alignment guide (24) to  
align a valley (30) of the impingement plate side with the impingement target area  
(22) during the step of joining the first mold part, the second mold part and the  
alignment guide together.

10. The method of claim 7, further comprising forming the second mold part to  
define the impingement plate side of the body as an auxetic surface shape (32).

11. The method of claim 10, wherein the auxetic shape surface (32) comprises  
30 peaks (29) and valleys (30) relative to the impingement surface side, and a valley of  
the auxetic shape is aligned with the impingement target area (22) by the alignment  
guide (24).

12. A wax pattern (66) comprising the core (10) of claim 1.

13. A casting mold (72) comprising the core of claim 1.

5 14. A method comprising casting a metal component in a casting mold (72) comprising the core (10) of claim 1.

15. A method of forming a cast metal component (76), the method comprising:  
applying a layer of wax (60) over the impingement plate side (14) of the core (10)  
10 of claim 1, the layer of wax surrounding the alignment guide (24) extending beyond the impingement plate side;

attaching the core and the layer of wax to a wax base (64) to form a wax pattern (66);

forming a shell (68) around the wax pattern;

15 removing the layer of wax and wax base from the shell to form a casting mold (72);

introducing molten metal into the casting mold and allowing the metal to cool and to solidify therein to form the cast metal component (76); and

removing the cast metal component from the casting mold;

20 wherein a location of the alignment guide (24) of the core (10) defines an impingement jet flow path (92) in the cast metal component extending from an outlet opening (90) formed through the impingement plate (88) to the impingement target area (86) of the impingement cooling feature (84).

25 16. The method of claim 15, further comprising demolding the cast metal component by:

removing the alignment guide (24) from the outlet opening (90); and

introducing a leachate through the outlet opening to dissolve a body (12) of the core (10).

30

17. The method of claim 15, further comprising inspecting the impingement cooling feature via access through the outlet opening (90).

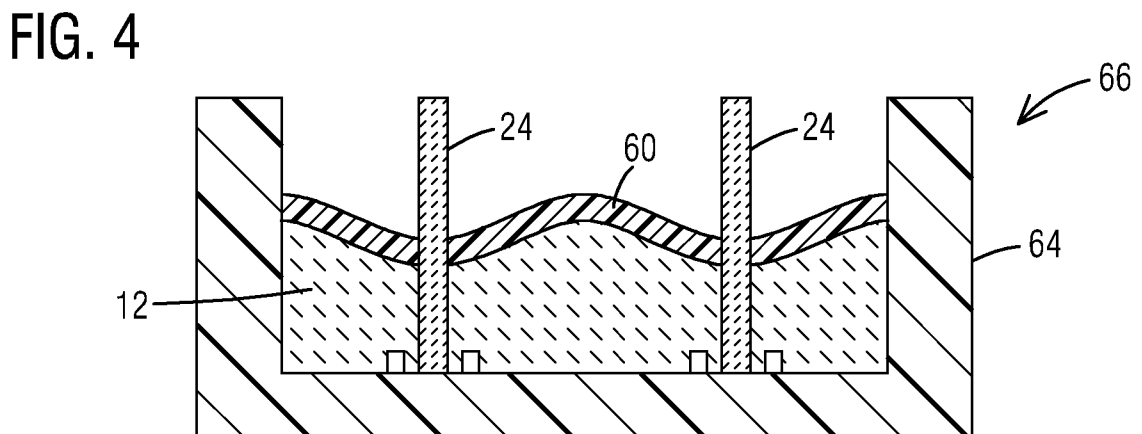
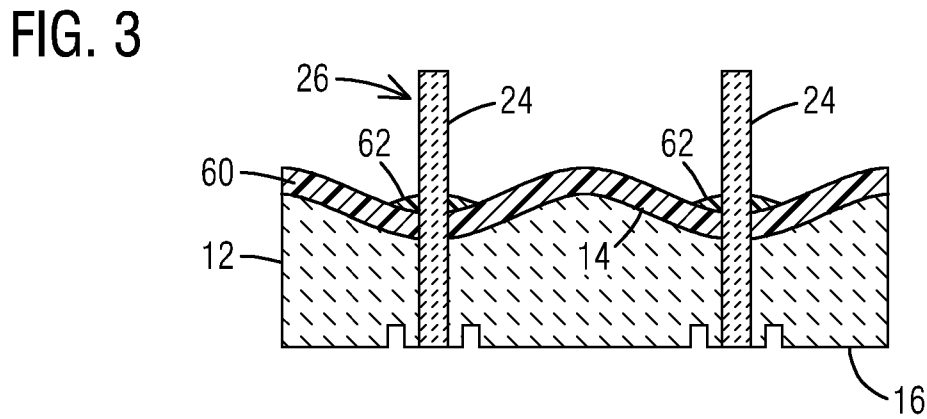
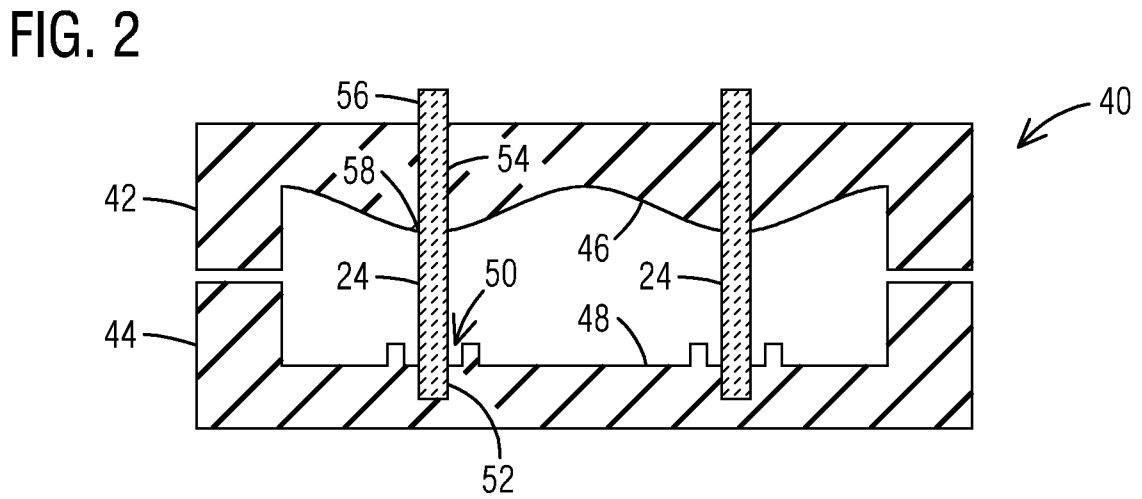
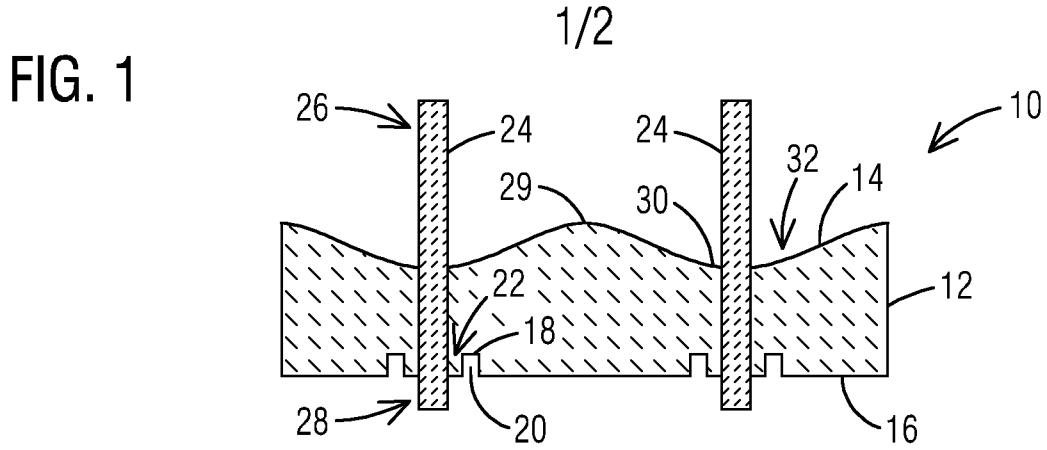

FIG. 5

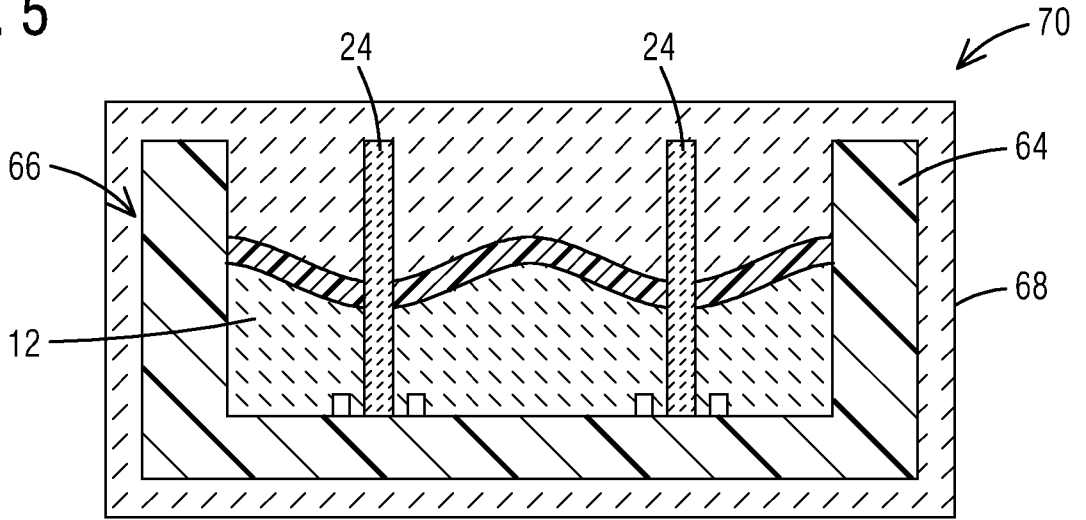

FIG. 6

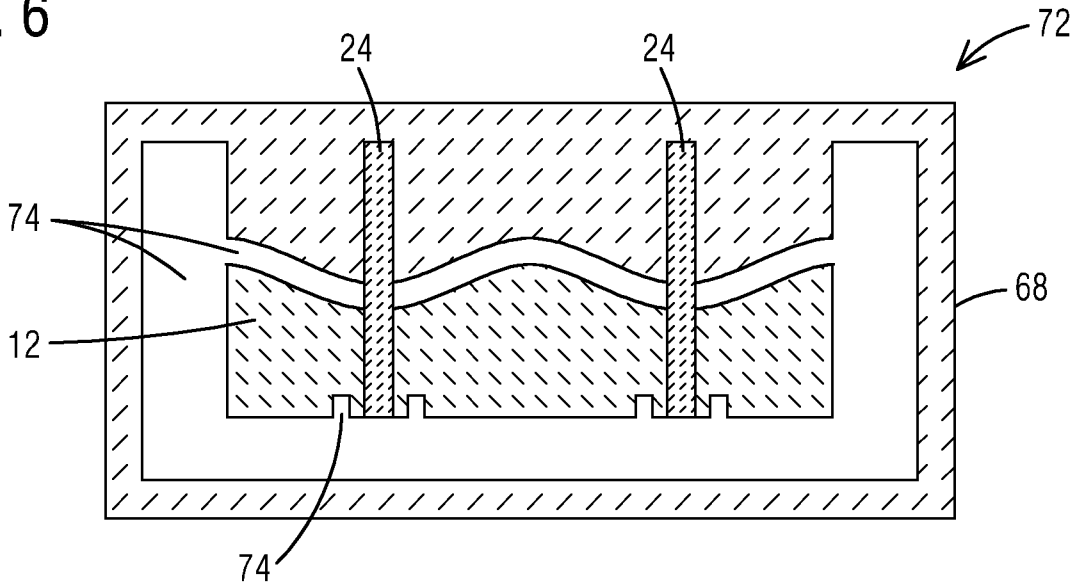

FIG. 7

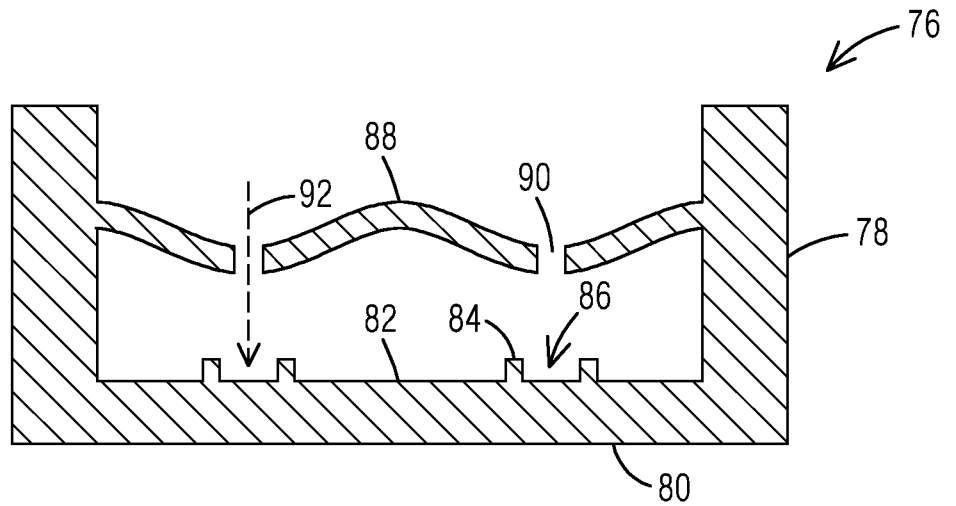

FIG. 6

