

No. 744,563.

PATENTED NOV. 17, 1903

G. W. KING.
COLLAPSIBLE OR FOLDING BOX FOR HOLDING FRUIT,
CONFECTIONERY, PASTRY, &c.

APPLICATION FILED MAR. 22, 1902.

NO MODEL.

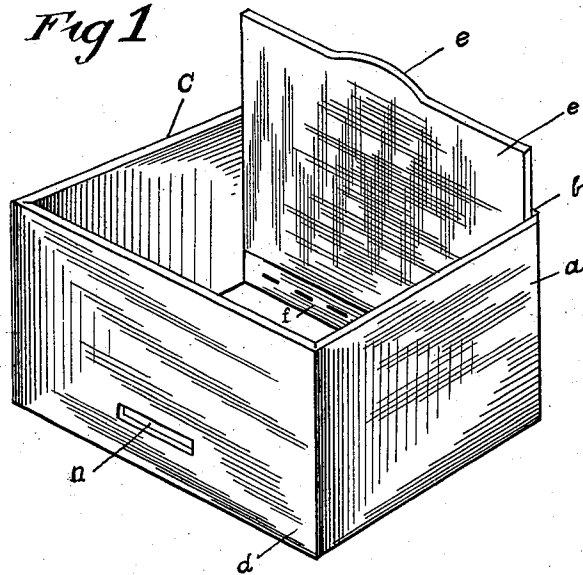
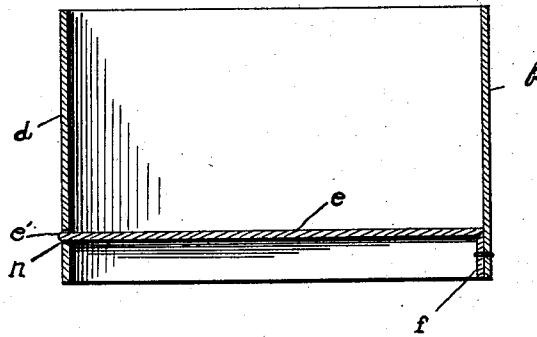

Fig 2.



Witnesses:
H. E. Manning
H. H. Simms

Inventor:
George W. King
By August H. Cross
attys.

UNITED STATES PATENT OFFICE.

GEORGE W. KING, OF GLASGOW, SCOTLAND.

COLLAPSIBLE OR FOLDING BOX FOR HOLDING FRUIT, CONFECTIONERY, PASTRY, &c.

SPECIFICATION forming part of Letters Patent No. 744,563, dated November 17, 1903.

Application filed March 22, 1902. Serial No. 99,470. (No model.)

To all whom it may concern:

Be it known that I, GEORGE WILLIAM KING, merchant, of 154 St. Vincent street, Glasgow, Scotland, have invented certain new and useful Improvements in and Connected with Collapsible or Folding Boxes for Holding Fruit, Confectionery, Pastry, or other Fragile Goods, of which the following is a specification.

This invention relates to collapsible or folding boxes. Its object is to provide a box which may be quickly and easily assembled and disassembled and which will be inexpensive to manufacture.

With these and other objects in view the invention consists in certain parts and combinations of parts, as will be hereinafter fully described, and pointed out in the appended claim.

In the drawing forming a part of this specification, Figure 1 is a perspective view of my improved box with the bottom raised, and Fig. 2 is a vertical section of the box.

Like letters indicate like parts through the specification and drawings.

In carrying out my invention I make the four sides *a b c d* of the box of one piece of thin wood or other suitable material which is scored across the grain and folded over, so as to make the sides and enable the box to be collapsed together when required; the two ends being connected together by means of glue, paste, wire stitches, small rivets, or other suitable fastenings. The bottom *e*, which is a separate piece, is scored across its whole breadth, thereby providing an attaching part on *f*, which is riveted or otherwise secured to one of the sides of the box and a hinge, so that when the box is in the collapsed state for packing or otherwise the bot-

tom can be raised up and will rest against the sides of the box, as shown in Fig. 1. In the side of the box opposite the hinge of the bottom of the box there is a horizontal slit *n*, in which a segmental extension *e'*, integral with and extending in the plane of the bottom, engages when the box is open ready for use. In this case the bottom of the box could not be inadvertently pushed up from the bottom and so displace the contents.

When this box is set up from its knock-down position, the integral extension automatically enters the horizontal slit and forms a support for the front side of the bottom. Further, the segmental extension *e'* conforms to the shape of the box when said box is bent to remove or insert the segmental extension from or in horizontal slit *n*. No sharp corners are provided which tend to enter the veneer in the direction of its grain and split the same.

What I claim is—

A collapsible or folding box constructed with four sides, and adapted to be collapsed, one of said sides being provided with a horizontal slit; a hinged bottom scored across its breadth to provide an attaching portion which is secured within the box, to the side opposite the side with the slit, and a segmental extension integral with and extending in the plane of the bottom, adapted to fit in the slit to lock the cover in position.

In testimony whereof I have hereunto affixed my signature in presence of two witnesses.

GEO. W. KING.

Witnesses:

JOHN LIDDLE,
AGNES MACKINTOSH.