

W. E. ELLIS.
 FASTENER FOR SHOE UPPERS.
 APPLICATION FILED NOV. 3, 1909.

999,765.

Patented Aug. 8, 1911.

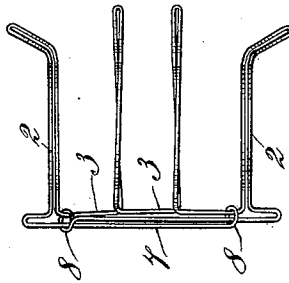

FIG. 1.

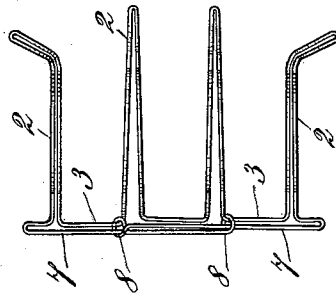

FIG. 2.

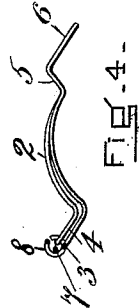

FIG. 3.

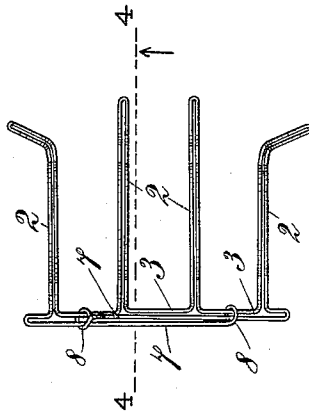

FIG. 4.

WITNESSES=

Joseph C. Brunson.
Anna B. Lindsay.

INVENTOR=

W. E. Ellis,
 By E. D. Chadwick,
 Attorney

UNITED STATES PATENT OFFICE.

WARREN E. ELLIS, OF HAVERHILL, MASSACHUSETTS, ASSIGNOR TO ELLIS LACER COMPANY, OF HAVERHILL, MASSACHUSETTS, A CORPORATION OF MAINE.

FASTENER FOR SHOE-UPPERS.

999,765.

Specification of Letters Patent.

Patented Aug. 8, 1911.

Application filed November 3, 1909. Serial No. 525,987.

To all whom it may concern:

Be it known that I, WARREN E. ELLIS, a citizen of the United States, and a resident of Haverhill, in the county of Essex and State of Massachusetts, have invented certain new and useful Improvements in Fasteners for Shoe-Uppers, of which the following is a specification.

This invention relates to fastening devices for securing together the eyeleted edges of the uppers of lace shoes while they are being lasted, and is intended to improve upon prior devices of this character in certain particulars which will hereinafter appear.

A fastener embodying my invention, as preferably constructed, is illustrated in the accompanying drawings, in which,

Figure 1 is a plan view of the fastener in its normal position; Fig. 2 is a similar view showing the fastener adjusted to increase the distance between its eyelet-connecting tongues; Fig. 3 is a similar view showing the fastener adjusted to decrease the distance between said tongues; and Fig. 4 is a cross sectional view on the line 4-4 in Fig. 1.

My improvements are particularly adapted to be embodied in fasteners of the "Ellis lacer" type, so called, and in the drawings I have illustrated such a lacer having four eyelet-connecting tongues 2 formed from doubled portions of a single piece of spring wire and connected at one end by portions 3 of said wire, the several tongues being provided with opposed eyelet-engaging portions 4 and 5 and with bent-over free ends 6 having the same construction, function and mode of operation as the corresponding parts of the fastening device shown in my prior U. S. Letters Patent No. 825,710, granted on the 10th day of July, 1906, to which reference may be made for a fuller description thereof.

Referring now to the construction of the lacer at the connected ends of the tongues, the terminal portions 7 of the wire from which the lacer is made are bent backward from the bases or connected ends of the outer tongues and arranged in substantial parallelism with and adjacent to the portions 3, and connections are provided between said portions 3 and 7, whereby the portions 7 serve as reinforcements for the portions 3 and render the lacer much less likely to be accidentally bent out of

shape than is a lacer of the same general type which does not contain this feature. By reason of this arrangement I am able to construct a lacer from lighter wire than heretofore and thus to increase the flexibility of its tongues, a result which is highly desirable in that it permits the lacer to adjust itself closely to the contours of different lasts. Various arrangements may be employed for connecting the portions 7 to the portions 3, but preferably, as in the lacer illustrated, this is accomplished by bending the ends of said portions 7 into loops or coils 8, the loop formed on each portion 7 being caused to surround the other portion 7 and also one of the connecting portions 3.

My invention also includes an arrangement whereby the several tongues of the lacer can be adjusted toward or away from one another to correspond with different spacing of eyelets in the shoes in connection with which it is to be used, so that it will be unnecessary for a shoe manufacturer to provide himself with an equipment of lacers to correspond with each different spacing of the eyelets in the shoes which he makes. To this end the lacer is so formed that each of the connecting portions 3 is normally located in a slightly different plane from the adjacent portion or portions 3, so that if the outer tongues 2 are crowded together the two portions of the doubled wire composing each intermediate tongue will pass one over the other to a certain extent and assume a crossed relation, as shown in Fig. 3, while if the outer tongues 2 are pulled apart the two portions of the doubled wire composing each intermediate tongue will be slightly separated as shown in Fig. 2, thus providing in either case for an adjustment of the lacer to correspond with the spacing of the eyelets in the upper to which it is to be applied.

In the particular construction illustrated, the loops 8 are normally located about midway of the portions 3 which they encircle, so that they can slide along the latter toward one end or the other as the spacing of the tongues is varied. Said loops also form stops to limit the adjustment of the lacer, so that the distortion of the tongues in any position of adjustment will be insufficient to permanently deform the lacer or to prevent the tongues from passing through

the eyelets and performing their usual function in connection therewith. Being made of spring wire, the tongues 2 when released will automatically return to their normal, intermediate position shown in Fig. 1.

My improvements may be employed in lacers having more or less than four eyelet-connecting tongues, and the particular construction of the eyelet-engaging devices on these tongues is not material to the invention.

I claim as my invention:—

1. A fastener for shoe uppers comprising a plurality of transversely-extending, eyelet-engaging tongues formed from doubled portions of spring wire and connected to one another at their adjacent ends, the adjacent connecting portions between said ends being normally located in slightly different planes, whereby the distances between the several tongues may be lessened by causing the two portions of each intermediate tongue to cross one over the other.

2. A fastener for shoe uppers comprising a plurality of transversely-extending, eyelet-engaging tongues made from spring wire and each provided between its ends with means for engaging a pair of opposite eyelets, said tongues being connected to one another at their adjacent ends by integral portions of the wire located on one side of the fastener, and means for reinforcing said integral connecting portions.

3. A fastener for shoe uppers made from a single piece of spring wire and comprising a plurality of eyelet-engaging tongues connected to one another at their adjacent ends, the terminal portions of said wire being located adjacent to and in substantial parallelism with the connecting portions between said ends, and means for connecting said terminal portions to said connecting portions.

4. A fastener for shoe uppers made from a single piece of spring wire and comprising a plurality of eyelet-engaging tongues connected to one another at their adjacent ends, the terminal portions of said wire being located adjacent to and in substantial parallelism with the connecting portions between said ends and provided with loops encircling said connecting portions and adapted to slide thereon.

5. A fastener for shoe uppers comprising a plurality of transversely-extending, eyelet-engaging tongues formed from doubled portions of spring wire and connected to one another at their adjacent ends, the adjacent connections between said ends being normally located in slightly different planes, and reinforcing portions located adjacent to said connecting portions and having a sliding connection therewith.

6. A fastener for shoe uppers constructed from a single piece of spring wire and comprising a plurality of transversely-extending, eyelet-engaging tongues each formed from a double portion of said wire and connected with the adjacent tongue or tongues at one end thereof, the adjacent connecting portions between said tongues being normally located in slightly different planes and the terminal portions of the wire being arranged in parallelism with and adjacent to said connecting portions and each bent at its end into a loop encircling the other terminal portion and the adjacent tongue-connecting portion about midway of the latter.

In testimony whereof, I have hereunto subscribed my name this 30th day of October, 1909.

WARREN E. ELLIS.

Witnesses:

E. D. CHADWICK,
JOSEPH T. BRENNAN.