

(12) **UK Patent Application** (19) **GB** (11) **2 237 028** (13) **A**
(43) Date of A publication 24.04.1991

(21) Application No **9017228.9**

(22) Date of filing **06.08.1990**

(30) Priority data

(31) **890100674** (32) **20.10.1989** (33) **GR**

(71) Applicant

Alexis Stassinopoulos
P.O. Box 87, 19400 Koropi Attica, Greece

(72) Inventor

Alexis Stassinopoulos

(74) Agent and/or Address for Service

Haseltine Lake & Co
Haziitt House, 28 Southampton Buildings,
Chancery Lane, London, WC2A 1AT, United Kingdom

(51) INT CL⁵

C10L 5/40 5/48

(52) UK CL (Edition K)

C5G GEX G711 G714

(56) Documents cited

EP 0262083 A1 WO 79/00988 A JP 57187392 A
JP 57057796 A US 3947255 A

(58) Field of search

UK CL (Edition K) C5G GDA GDB GDC GDD GEX
INT CL⁵ C10L

Online databases : WPI; CLAIMS

(54) **"Solid fuel from municipal plastic waste"**

(57) A solid fuel comprises a mixture of plastics, originating from municipal waste and wooden materials together with inert materials.

The municipal plastic waste may be ground, mixed with wooden materials and undergo an extrusion process, whereby granules or continuous rods and bars are produced, subsequently cut to the desired length.

The solid fuel product is used in stoves and solid fuel burners.

GB 2 237 028 A

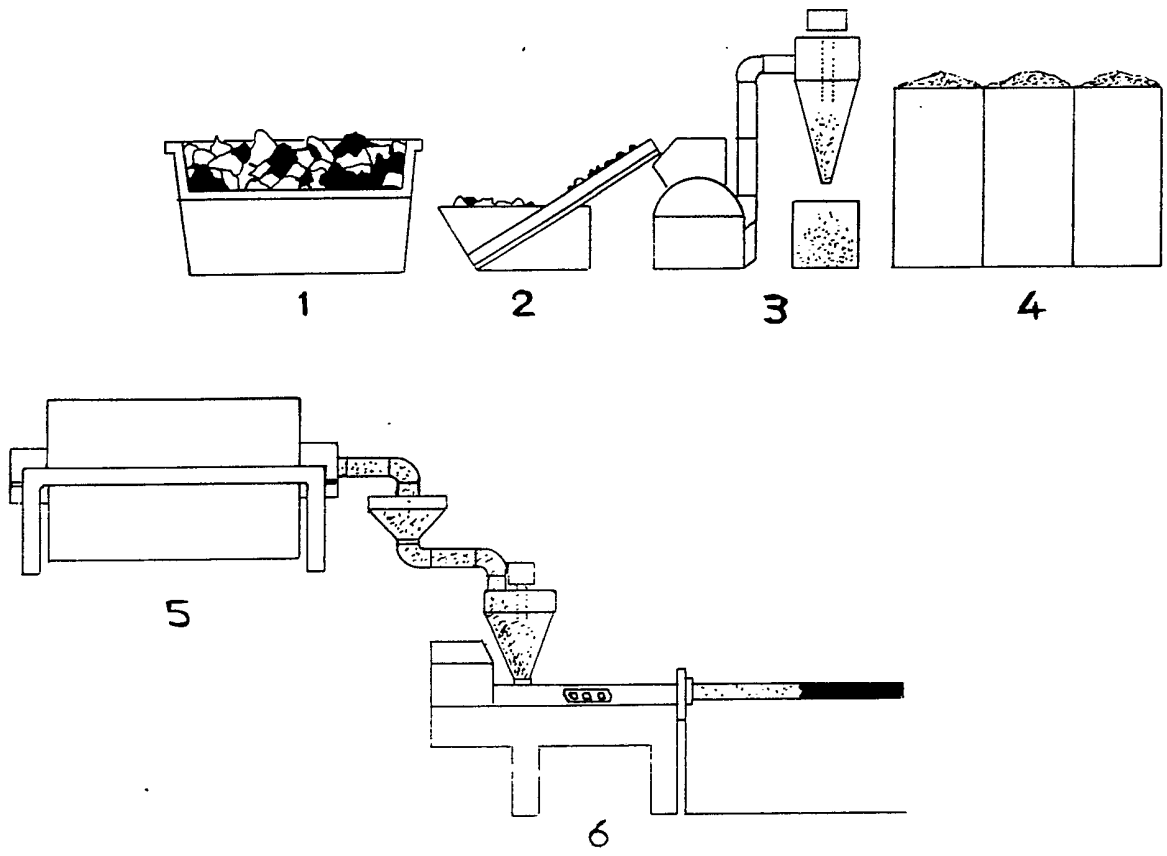

FIG. 1

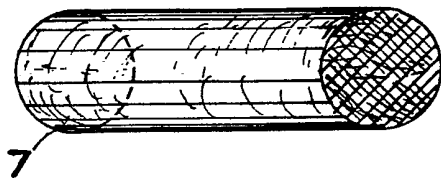

FIG. 2

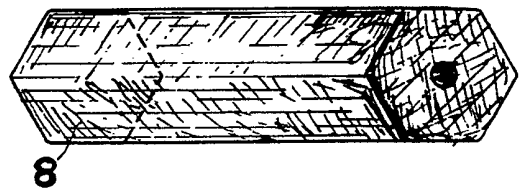

FIG. 3

SPECIFICATION OF INVENTION

TITLE: " Solid fuel from municipal plastic waste,
wooden and inert materials and method of
preparation of the same"

THE FIELD OF THE INVENTION

The present invention relates to the field of the art of
exploitation of the plastics contained in municipal waste. In
particular, herein is described a new method for the
exploitation of the calorific value of such a mixture of
5 plastic waste in the production of a new standardised solid
fuel.

THE BACKGROUND OF THE INVENTION

The increased population mainly in large urban centres
has resulted in the increased volume of municipal waste, the
10 collection and disposal of which has already caused an acute
economic and environmental problem.

By way of example in Greece, the average daily per capita
amount of municipal waste is 850 gr. Making a special
reference to Attica, the broader region around the
15 capital of Greece, Athens, over a million tons of municipal
waste are produced annually. The term solid municipal waste
is used herein to describe domestic garbage which in
accordance to the practice presently employed in Greek cities
are disposed by means of sanitary landfill into the few

official and the multifold (around 5,000) unofficial landfill sites or common usage areas. Relevant figures can be obtained from the following references:

- 5 - "Domestic garbage analysis in the Broader Athens region", PERPA/Union of Municipalities of the prefecture of Attica (1980).
- "Study for recycling plastic waste", Eastern Crete Department of the Technical Chamber of Greece (1986).
- 10 - "Elaboration of Statistical data of the Experimental Program-Sorting at the source", Union of Municipalities of the prefecture of Attica (1987).

15 The analysis of the average percentage content of municipal waste in various materials, for the case of Athens is given in Table I below. These figures have been obtained from the "Domestic garbage analysis in the broader Athens region", PERPA/Union of Municipalities of the prefecture of Attica (1980).

TABLE I Composition of Municipal waste in the broader Athens region

Category	Percentage	Quantity
	Composition	(in tons)
5 Fermentable materials	59,80	630,000
Paper/cardboard	19,50	205,000
Plastics	7,00	73,000
Metals	3,80	40,000
Glasses	2,60	27,000
10 Cloth, Wood, leather, Rubber materials	3,45	36,000
Inert Materials	0,70	8,000

The continuous increase in the volume of the waste and the difficulty in allocating new sites for their disposal, obviously lead to the result that the presently used method of collection and disposal of the waste will not be sufficient to employ by itself indefinitely, but it must be combined with other methods basically aiming to the recycling of the whole or part of its constituents. Such proposals are made in "Packaging, Environment and Recycle: A scientific assessment", L.L.Katan (Elsevier 1987).

It is of particular significance to develop methods and integrated systems for the recycling of plastic materials contained in municipal waste, for the following reasons:

- Plastic waste are hard to disintegrate, even those which are bio - or photo - degradable, this resulting to

their piling up and occupying substantial space in the landfill sites.

- Plastic waste are a valuable and unexploited raw material both for the production of new products and for the production of energy.

It is for these abovementioned reasons that a very substantial effort is made nowadays for the development of new methods of collection (sorting at the source) and usage of plastic waste, as well as of developing new products where plastic waste may be used as a raw material. Such ideas are by way of example contained in the following references:

- "Recycling of Plastics-International Technoeconomic Report" - Vladimir M.Wolpert (1989), and
- "Research Program-Recycling of Plastic wastes - Summary Projects 1-8", Verband Kunststoffherzeugende Industrie (1982).

A typical composition in a mixture of municipal plastic waste with regard to the constituent plastics is given in Table II, below.

Table II. Typical composition of the mixture of plastics contained in Municipal waste

<u>Category</u>	<u>Percentage (%)</u>
Polyolefins	65
5 Polystyrene	14
Polyvinyl chloride	9
Polyethylene terephthalic ester (PET)	7
Other	5

10 The main difficulties encountered in exploiting the mixture of plastics contained in municipal waste are the following:

 - Difficulty in cleaning and sorting the different constituent plastics. The cost of such sorting is so large, 15 that it could make the entire process economically unacceptable, if it necessitated sorting of clean materials.

 The process of recovery of clean plastics may be advantageously employed if materials of a special category are collected, such as by way of example PET bottles or rural 20 film.

 - Employing of the mixture of plastics, without any prior treatment in the manufacturing of products as substitute to wood is rather limited because of the cost of the proposed plants and the relatively small consumption of such products.

25 - Combustion of the plastics or of mixtures of waste

including plastics is an important solution, yet it requires substantial investment in special combustion units.

- Usage at a percentage of between 5 and 8% of the mixtures of plastic waste in tarmacadams is an important application, which is presently in an experimental stage.

- Thermal decomposition of plastic mixtures in order to obtain liquid and gas fuels is a method, the employment of which would require large plants continuously supplied with particularly extensive quantities of plastics.

The solution to the problem of plastics recycling will not receive a single answer in future. Depending on each particular case one or the other method of those presently proposed or those that might be proposed in future would be employed.

One of the most important ways of exploiting the mixtures of plastic waste is their combustion for the production of hot air, steam or electric energy.

The energy supplied from combustion of various plastics is given in Table III below. The same Table provides comparative figures for conventional fuels. Finally, in Table III the exhaust combustion gases are listed in each particular case.

Table III. Heat produced during combustion of plastics and other combustible materials

Material	Combustion Heat (MJ/Kg)	Exhaust Combustion gases
5 Polyethylene (PE)	43,3	CO ₂ , H ₂ O
Polypropylene (PP)	44,0	CO ₂ , H ₂ O
Polystyrene (PS)	40,0	CO ₂ , H ₂ O
Polyethylene terephthalic ester (PET)	31,4	CO ₂ , H ₂ O
10 Polyvinyl Chloride (PVC)	18,0	CO ₂ , H ₂ O, HCl
Oil	42,2	CO ₂ , H ₂ O (*)
Coal	29,0	CO ₂ , H ₂ O (*)
Lignite		CO ₂ , H ₂ O (*)
Wood	15,0-17,0	CO ₂ , H ₂ O (*)
15 Paper Pulp	13,0-15,0	CO ₂ , H ₂ O (*)

(*) Including a smaller percentage of SO_x and NO_x

In Table III, one can see that combustion of plastics results to a production of heat corresponding to that of oil, whereas the exhaust combustion gases are the same as those produced during combustion of conventional combustible materials (CO₂ and H₂O), with the exemption of PVC, combustion of which additionally produces acid gases (HCl).

Referring by way of example to the publication "Recycling of Plastics - International Technoeconomic Report"-Vladimir M.Wolpert (1989)-, one finds that mixtures of municipal waste

are already used as fuel in the production of thermal or electric energy. This process is both possible and economically advantageous when the mixture of waste is rich in combustible materials and especially plastics.

5 Plastic waste have not up today been used as combustible materials in themselves and in a domestic scale (stoves, fireplaces) or using burners of the type used to burn coal or other solid fuels. This is due to the following reasons:

10 - It is not possible to control and regulate combustion, since it is not possible to feed with a homogeneous combustible material, as far as the thermal performance and specific volume is concerned.

15 - Stoves, fireplaces and solid fuel burners cannot accept materials which, prior to being burnt, melt and flow away from the fireplace.

A first object of the present invention is to effectively overcome these disadvantages and provide a new method for the exploitation of the thermal value of the plastic materials contained in municipal waste, where the proposed method
20 comprises manufacturing by means of a suitable procedure of standard pieces of solid fuel of a high thermal value.

A second object of the present invention is manufacturing of the abovementioned standardised solid fuel from plastic waste in suitable combination with wooden materials and a
25 small quantity of combustion regulatory materials, with the solid fuel having stable and controlable properties.

A further object of the present invention is to provide a

model production plant of the proposed solid combustible material.

Another object of the present invention is to provide the proposed solid combustible material in a standardised shape and dimensions so as to offer reduced cost as well as to
5 facilitate storage, transport and usage of the same.

A final object of the present invention is to provide a broad field of applications for the new combustible materials, based on plastic waste.

10 These and other objects, characteristics and advantages of the invention will be made apparent in the detailed description below.

BRIEF DESCRIPTION OF THE DRAWINGS

The present invention will be made apparent to those
15 skilled in the art from the attached drawings, wherein the invention is depicted in an illustrative manner.

Figure 1 shows a typical arrangement of a production unit for the proposed solid combustible material based on the plastics contained in municipal waste.

20 Figure 2 shows a perspective view of an illustrative rod of the solid combustible material of a cylindrical section, which is produced in accordance to the method of the invention.

Figure 3 shows a perspective view of an alternative
25 illustrative rod of the solid possible material with a hexagonal section.

DETAILED DESCRIPTION OF THE INVENTION

The various parts depicted in the drawings are enlisted below in an order corresponding to their reference numerals in the accompanying drawings:

- 5 1. Tank for loading the mixture of plastic waste.
2. Arrangement for the control and removal of PVC materials.
3. Arrangement for grinding plastic materials.
4. Storage tank for the ground product.
- 10 5. Arrangement for mixing with wooden and inert materials.
6. Extruder for the production of standardised rods of solid fuel.
7. Typical cylindrical rod of the solid combustible material produced.
- 15 8. Typical hexagonal bar of the produced solid combustible material.

In accordance to the typical production unit depicted in the drawings, the method of production of the solid combustible material comprises the following stages:

20 Initially, a mixture of uncleaned plastic waste (collected in municipal buckets specially dedicated to this purpose) with a typical composition, as described in the above Table II is collected in tank I. The fermentable materials, metals, glasses, wood, leather, cloths, rubber, paper and PVC materials have been removed prior to collection

in tank 1. The mixture of plastic waste materials is therefrom fed into an arrangement 3, which comprises one or more grinding mills, where the mixture of plastics is ground into homogeneous granules and is subsequently transferred
5 into the storage tank 4.

The plastic raw material collected within tank 4 is therefrom supplied to the arrangement 5, where it is mixed with wooden and inert materials, thereby obtaining the desirable composition of the fuel produced. The materials
10 used in this mixing process with the plastics to produce the possible raw material of the invention can be any wooden material available, such as sawdust, olive kernel extraction residue or various other agricultural cellulosic waste, etc. A small percentage of inert, combustion regulatory materials
15 is added to the mixture.

In accordance to a preferred, illustrative embodiment of the invention, the combustible material produced comprises an approximate one half of plastics mixture and an approximate other half of wooden and inert constituent materials. In
20 particular and in accordance to a typical embodiment of the invention, a mixture of plastics is used at a percentage of 55%, olive kernel extraction residue or other agricultural cellulosic waste at a percentage of 40% and inert additives at a percentage of 5%.

25 In accordance to a preferred, illustrative embodiment of the invention, prior to the eventual grinding of the mixture of plastics, those plastics which form acid combustion

products have to be removed, i.e. PVC articles have to be removed. It is for this reason that the plastic materials discharged from the waste plastics mixture tank 1 are transferred, prior to the grinding arrangement 3, to an arrangement of control and removal of PVC articles. This arrangement 2 by means of which PVC materials are located and removed comprises in accordance to an illustrative preferred embodiment of the invention manual removal following a visual control during movement of the mixture of plastics onto a conveyor belt of arrangement 2, whereas alternatively such control and removal may be carried out automatically by means of well known in the art separation techniques.

The ground plastics supplied from the storage tank 4 are mixed with wooden materials and inert additives into the mixing arrangement 5.

Part of the plastics and in particular plastics wherefrom PVC has not been removed are used employing a suitable extrusion arrangement for the production of desired plastic articles (e.g.pipes or rods).

The mixture of plastics with wooden and inert materials produced in the arrangement 5 is used in two basic ways:

- Production of homogeneous granules straight after the mixing arrangement 5 or following passage through a suitable extruder, thereby being burnt in furnaces to produce thermal energy. In this way many applications may be advantageously carried out, such as by way of example rural applications (drying of agricultural products, heating of greenhouses,

etc.), but urban applications as well, such as remote heating of groups of buildings, etc.

5 - Production in accordance to the depicted preferred embodiment of the invention of standardised pieces of solid combustible material.

10 The standardised pieces of solid combustible material produced by means of the single or double screw extruder employed in the process, come out in the form of continuous solid or perforated rod in various sections at a temperature in the range of 80-150° C and following cooling, by way of example within a water tank at a temperature of the order of 60° C, the continuous rod of possible material is cut into an arrangement of automatic cutting to produce the standardised pieces of combustible material.

15 This combustible material can be used onto fire grids which have been manufactured for the combustion of wood, coal and other solid fuels, without any amendment (fireplaces, stoves, mixed usage central heating burners or mixed usage burners for the production of steam).

20 Figures 2 and 3 show illustrative shapes of the final products of combustible material. By way of example, Figure 2 shows a rod 7 of cylindrical cross section, which given illustrative dimensions of length 3-5cm and diameter 5 cm is suitable as a briquette for a solid fuel burner. With the
25 shape depicted in Fig.3, the solid fuel is provided in the form of a solid piece 8 with a hexagonal section, which is perforated and has dimensions of width 15 cm and length 30

cm. In this form the solid fuel of the invention is suitable for burning in a fireplace, whereas the hexagonal shape ensures a substantial economy in storage space. The same hexagonal section can be used to produce solid pieces with illustrative dimensions of width 10 cm and length 15 cm, particularly suitable for burning in solid fuel stoves.

With the abovementioned illustrative composition, the new fuel has the following characteristics:

- It supplies heat of the order of 28 MJ/Kg, i.e. comparable to the thermal energy of coal.
- It has a uniform shape and thermal performance.
- It is free of coal dust or insects and it does not soot.
- Its hexagonal section facilitates storage.
- It is non hygroscopic and contains a very small percentage of moisture, because of the controlled production process. Notably, the extruder preferably includes an arrangement for ventilation and removal of moisture.
- Because of its non-hygroscopic nature, it is not possible to adulterate the proposed solid fuel, as is the case with wetting of firewood.

The proposed new fuel further has notable characteristics of an environment friendly fuel, the most important of which are the following:

- It constitutes a solution in the energy exploitation of an offensive category of garbage, such as plastics.
- It substitutes wood in combustion in fireplaces and

stoves and thereby saves trees. .

- It substitutes oil and coal in mixed combustion burners for the production of steam and heating.

5 - The combustion gases are at least equally "clean" to any other natural fuel.

10 It must hereby be noted that the description of the invention was made by reference to illustrative examples and it is not confined into these examples. Thus, any change or amendment relating to the sizes, shape, field of applications, materials and accessories used, etc., as long as they do not comprise a new inventive step and do not contribute towards further technical development of the state of the art, must be considered part of the scope and the aims of the present invention.

CLAIMS

1. Solid fuel comprising granules of a mixture of municipal plastic waste (polyolefins, polystyrene, polyethylene terephthalic ester, etc.) mixed with wooden materials (saw dust, olive kernel extraction residue, 5 agricultural cellulosic waste, etc.) and inert materials in any selected proportions, where the said solid fuel is offered in the form of uniform granules.

2. The solid fuel of Claim 1, where the said mixture of municipal plastic waste is used in a proportion of 55%, 10 kernels or other wooden materials are used in a proportion of 40% and inert combustion regulatory materials in a proportion of 5%.

3. The solid fuel of Claim 2, which is extruded and subsequently cut to standard granules and pieces of solid or 15 perforated rod of a desired section, where the said solid fuel is offered for combustion onto solid fuel fire grids, such as in fireplaces, stoves, solid fuel or mixed usage burners.

4. The solid fuel of claim 3, which is produced in the 20 form of cylindrical solid or perforated rod.

5. The solid fuel of Claim 3, which is produced in the form of hexagonal solid or perforated bar, thereby ensuring minimization of storage space.

6. Method of production of a solid fuel prepared from a 25 mixture of municipal plastic waste with wooden and inert

materials, comprising the following stages:

- loading the mixture of plastics;
- grinding the mixture of plastics;
- mixing with wooden and inert materials to produce a
5 uniform mixture of a desired composition.

7. The method of production of a solid fuel prepared from
a mixture of municipal plastic waste with wooden and inert
materials of Claim 6, where the said uniform mixture produced
comprises a mixture of municipal plastic waste in a
10 proportion of 55%, kernels or other wooden materials in a
proportion of 40% and inert combustion regulatory materials
in a proportion of 5%.

8. The method of production of a solid fuel prepared from
a mixture of municipal plastic waste with wooden and inert
15 materials of Claim 7, further comprising an arrangement for
locating and separating PVC articles from the mixture, prior
to the eventual grinding.

9. The method of production of a solid fuel prepared from
a mixture of municipal plastic waste with wooden and inert
20 materials of Claim 8, where the removed PVC articles either
independently or in common with a portion of the other
plastic materials contained in the mixture of municipal
plastic waste are used for the production of plastic articles
(rods or pipes) into suitable plastics machinery.

25 10. The method of production of a solid fuel prepared from
a mixture of municipal plastic waste with wooden and inert
materials of Claim 9, where the said uniform mixture of

granules consisting of plastics, wooden and inert materials
is supplied to an extruder wherefrom a continuous, solid or
perforated rod of various selected shapes and sections is
produced, where the said continuous rod is subsequently cut
5 into solid fuel pieces of the desired dimensions.