



Europäisches Patentamt
European Patent Office
Office européen des brevets



(11) **EP 1 050 500 A3**

(12) **EUROPEAN PATENT APPLICATION**

(88) Date of publication A3:
25.04.2001 Bulletin 2001/17

(51) Int. Cl.⁷: **B65H 23/34, B65H 23/032,
D06C 3/00, D06H 7/08**

(43) Date of publication A2:
08.11.2000 Bulletin 2000/45

(21) Application number: **00108609.9**

(22) Date of filing: **20.04.2000**

(84) Designated Contracting States:
**AT BE CH CY DE DK ES FI FR GB GR IE IT LI LU
MC NL PT SE**
Designated Extension States:
AL LT LV MK RO SI

(72) Inventor: **van de Wouw, Frie
2016 Luxembourg (LU)**

(30) Priority: **28.04.1999 IT TO990347**

(74) Representative:
**Lotti, Giorgio et al
c/o Ing. Barzanò & Zanardo Milano S.p.A.
Corso Vittorio Emanuele II, 61
10128 Torino (IT)**

(71) Applicant: **Tex Electronic S.A.
2016 Luxembourg (LU)**

(54) **Device for centring and widening of a fabric strip**

(57) Centring/widening device adapted to widen and centre a fabric strip on a reference axis, consisting of two parallel tubes (41, 42) which are separated between them and face each other, for their entire length, by a part of their wall which presents nozzles adapted for the blowing in of pressured air sent through said tubes by a fan.

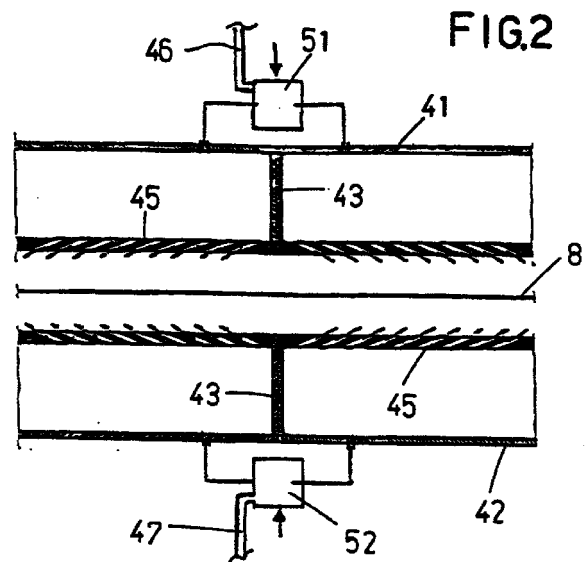

EP 1 050 500 A3



European Patent
Office

EUROPEAN SEARCH REPORT

Application Number
EP 00 10 8609

DOCUMENTS CONSIDERED TO BE RELEVANT			
Category	Citation of document with indication, where appropriate, of relevant passages	Relevant to claim	CLASSIFICATION OF THE APPLICATION (Int.Cl.7)
X	US 4 322 026 A (W.O. YOUNG) 30 March 1982 (1982-03-30) * the whole document * ---	1-6	B65H23/34 B65H23/032 D06C3/00 D06H7/08
X	US 4 422 308 A (M. PFEIFFER ET AL.) 27 December 1983 (1983-12-27) * the whole document * ---	1-6	
X	DE 196 43 524 A (CENTEX CHEMNITZER TEXTILMASCHINENENTWICKLUNG GMBH) 23 April 1998 (1998-04-23) * the whole document * -----	1-6	
The present search report has been drawn up for all claims			TECHNICAL FIELDS SEARCHED (Int.Cl.7)
			B65H D06H D06C
Place of search	Date of completion of the search	Examiner	
THE HAGUE	1 March 2001	D'Hulster, E	
CATEGORY OF CITED DOCUMENTS		T : theory or principle underlying the invention E : earlier patent document, but published on, or after the filing date D : document cited in the application L : document cited for other reasons & : member of the same patent family, corresponding document	
X : particularly relevant if taken alone Y : particularly relevant if combined with another document of the same category A : technological background O : non-written disclosure P : intermediate document			

EPO FORM 1503 03 82 (P04C01)

**ANNEX TO THE EUROPEAN SEARCH REPORT
ON EUROPEAN PATENT APPLICATION NO.**

EP 00 10 8609

This annex lists the patent family members relating to the patent documents cited in the above-mentioned European search report. The members are as contained in the European Patent Office EDP file on
The European Patent Office is in no way liable for these particulars which are merely given for the purpose of information.

01-03-2001

Patent document cited in search report	Publication date	Patent family member(s)	Publication date
US 4322026 A	30-03-1982	DE 3115098 A	04-02-1982
US 4422308 A	27-12-1983	DE 3025154 A	28-01-1982
		DE 3165949 D	18-10-1984
		EP 0043414 A	13-01-1982
		ES 503689 D	01-12-1982
		ES 8301298 A	16-02-1983
		JP 1252626 C	26-02-1985
		JP 57047964 A	19-03-1982
		JP 59026697 B	29-06-1984
DE 19643524 A	23-04-1998	NONE	